

U.S. NAVAL
Flight Surgeon's Manual

THIRD EDITION

1991

Prepared by
NAVAL AEROSPACE MEDICAL INSTITUTE



Under the auspices of

THE BUREAU OF MEDICINE AND SURGERY
Department of the Navy



For sale by the Superintendent of Documents, U.S. Government Office, Washington, D.C. 20402

Project direction by

Editorial Board

Naval Aerospace Medical Institute

Captain Ronald K. Ohslund, MC, USN
Captain Conrad I. Dalton, MC, USN
Commander Gary G. Reams, MC, USN
Commander Jerry W. Rose, MC, USN
Lieutenant Commander Richard E. Oswald, MC, USN

Project Managers

Commander Jerry W. Rose, MC, USN
Lieutenant Commander Richard E. Oswald, MC, USN

FOREWORD

As we quickly approach the 21st Century, the Navy Medical Department stands ready to take on some of the greatest challenges it has ever faced. With the Cold War now a part of history, we must learn to operate within a new world order; one in which we must maintain our level of readiness within the context of an ever changing geopolitical environment. Critical to our future success in responding to the needs of the Fleet and Fleet Marine Force will be our ability to synthesize past experiences into our current knowledge base while simultaneously projecting requirements into the future. One important way of accomplishing such a task is by the sharing of information as quickly and efficiently as possible. The Third Edition of the Flight Surgeon's Manual represents a major tool in this process. It is the culmination of 13 years of effort in distilling out the very best of aerospace science and technology.

We have entered a new era on the battlefield. Technology has made it possible for aircraft to out perform their occupants. Innovation has given us a glass cockpit whose avionics suite can easily overload the aviator not aided by multiple high speed computers. Weaponry has made it possible to inflict devastating physiologic damage without killing an aircraft's occupants or damaging the airframe. And we are poised on the verge of hypersonic mass transit. Each of these phenomena could not be understood or countered if it were not for the efforts of the Aerospace Medicine Team.

The Third Edition is dedicated to the pioneering spirit of those in operational medicine whose interests have kept our country strong and our course true to the cutting edge of technology. For it is only through the noteworthy efforts of all members of the Aerospace Medicine Community over the last several decades that we continue to carry on our proud tradition of quality medical support of the Fleet.

James A. Zimble
Vice Admiral, Medical Corps
United States Navy
Director of Naval Medicine/
Surgeon General

PREFACE

The unique aspect of aerospace medicine as practiced by a U.S. Naval Flight Surgeon is the requirement to function independently at isolated duty stations. Whether at sea, on a small patch of land in mid-ocean, or at expeditionary airfield of the Fleet Marine Force, Flight Surgeons are often called upon to make medical and administrative decisions which affect the lives and careers of the most critical assets in the naval service - members of the Naval Aviation community. Not only must we treat the day to day medical problems but we must be prepared to deal with a vast array of casualties which all too frequently remind us of the danger inherent in Naval Aviation.

This manual is both an introduction to the various aspects of Naval Aerospace Medicine and a guide for dealing with the other complex administrative procedures known as "the system." This revision has evolved from questions most frequently asked, errors most commonly made, with a dash of seasoned advice passed down to the youngsters. The manual should stand between the Manual of the Medical Department and a current text on aerospace medicine. It is written to provide the Flight Surgeon with a reminder of the material presented in the formal course of aerospace medicine and as a reinforcement of the fact that the U.S. Naval Flight Surgeon stands at the apex of military operational medicine.

The U.S. Naval Flight Surgeon's Manual was originally designed to be updated at frequent intervals. This revision is the first since 1977 and has therefore resulted in an extensive rewrite of most of the chapters. The plan is to keep the manual current through annual submissions of new material by the Naval Aerospace Medical Institute and through contributions from the users of this text.

R.K. Ohslund
Captain, MC, USN
Commanding Officer
Naval Aerospace Medical Institute

ACKNOWLEDGMENTS

The Third Edition of the U.S. Naval Flight Surgeon's Manual is the result of a team production with each member performing his required task. No one individual or select group of individuals was responsible. Some chapters are updates of the second edition; others have been completely rewritten.

The multiple tasks necessary for the publication of this manual were accomplished in addition to the normal duties of each contributor. Special recognition should be made of the contributing authors. They are:

Authors, Second Edition

LCDR Joseph M. Andrus, MC, USN
CDR Don S. Angelo, MC USN
CDR C.H. Bercier, MC, USN
CAPT O.G. Blackwell, MC, USN
CDR W.A. Buckendorf, MC, USN
CAPT. Eugene J. Colangelo, MC, USN
Ms. Jacque Devine
CAPT Frank E. Dully, Jr., MC, USN
CAPT F.S. Evans, MC, USN
Martin G. Every, MS
CAPT J.E. Felder, MC, USN
CDR Donald E. Furry, MSC, USN
LT James A. Gessler, MC, USN
Mr. James W. Greene
Frederick E. Guedry, Jr., Ph.D.
LT David T. Hargraves, MSC, USN
CDR Norman G. Hoger, MC, USN
CDR Gary L. Holtzman, MC, USN
CDR William M. Houk, MC, USN
CAPT Joseph Kerwin, MC, USN
CDR T.F. Levandowski, MSC, USN
LCDR Neil R. McIntyre, MC, USNR

U.S. Naval Flight Surgeon's Manual

CDR C.J. McAllister, MC, USN
CDR Richard A. Millington, MC, USN
CAPT J.D. Morgan, MC, USN
LCDR L.P. Newman, MC, USNR
CAPT P.F. O'Connell, MC, USNR
James F. Parker, Jr., Ph.D.
CAPT Joseph A. Pursch, MC, USN
Ronald M. Robertson, Ph.D.
CAPT. E.J. Sacks, MC, USN
CAPT Richard J. Seeley, MC, USN
CDR Phillip W. Shoemaker, DC, USN
LCDR Felix Zwiebel, MC, USN

Authors, Third Edition

CDR Michael R. Ambrose, MC, USN
CAPT James C. Baggett, MC, USN
Annette G. Baisden, MA
CDR Robert Bason, MSC, USN
CAPT Charles H. Bercier, Jr., MC, USN
CAPT S. William Berg, MC, USN
CDR Bruce K. Bohnker, MC, USN
CAPT Philip T. Briska, MC, USN
CDR Jonathan B. Clark, MC, USN
CDR D.E. Deakins, MC, USN
Chuck E. DeJohn, D.O.
LCDR Michael Dubik, MC, USN
LCDR William B. Ferrara, MC, USN
CDR James R. Fraser, MC, USN
Federick C. Guill, B.S.M.E., M.S.
LCDR Gerald B. Hayes, MC, USNR
LCDR F.D. Holcombe, MSC, USNR
CAPT Gary L. Holtzman, MC, USN
CAPT Robert E. Hughes, MC, USN
CDR Wesley S. Hunt, MC, USN
LCDR William L. Little, MSC, USN
LCDR Steven G. Matthews, MSC, USN
CAPT Andrew Markovitz, MC, USNR

U.S. Naval Flight Surgeon's Manual

LCDR Michael H. Mittelman, MSC, USN
CDR Carroll J. Nickle, MC, USN
CDR Richard G. Osborne, MC, USN
LCDR Richard E. Oswald, MC, USN
CDR Jerry W. Rose, MC, USN
CAPT E.J. Sacks, MC, USN

The essential logistic, clerical, and secretarial support which was vital to the successful completion of this project was carried out by:

Support Personnel

Word Processing

Karen Strickland Brewton
Sue Bondurant
Rose Ann Spitzer

Computer Assistants

CDR Bruce K. Bohnker, MC, USN
Michelle Marshall

Technical Publications Editor/Writer

Mary M. Harbeson

Technical Manuals Writer (Aircraft)

Claudia J. Lee

Technical Illustrations

Robert Lewis Scott

Fiscal Officers

LT Danny D. Urban, MSC, USNR
LTJG Roland E. Arellano, MSC, USN

Facilities Management

HMI Richard D. Wilson

TABLE OF CONTENTS

	<i>Page</i>
Chapter 1	
Physiology of Flight	1-1
Chapter 2	
Acceleration and Vibration	2-1
Chapter 3	
Vestibular Function	3-1
Chapter 4	
Space Flight Considerations	4-1
Chapter 5	
Internal Medicine	5-1
Chapter 6	
Psychiatry	6-1
Chapter 7	
Neurology	7-1
Chapter 8	
Otorhinolaryngology	8-1
Chapter 9	
Ophtalmology	9-1
Chapter 10	
Dermatology	10-1
Chapter 11	
Sexually Transmitted Diseases	11-1
Chapter 12	
Aerospace Psychological Qualifications	12-1
Chapter 13	
Aviation Medicine with Fleet Marine Forces	13-1

U.S. Naval Flight Surgeon's Manual

Chapter 14	
The Aircraft Carrier	14-1
Chapter 15	
Disposition of Problem cases	15-1
Chapter 16	
Aeromedical Evacuation	16-1
Chapter 17	
Medication and Flight	17-1
Chapter 18	
Alcohol Abuse and Alcoholism	18-1
Chapter 19	
Fatigue	19-1
Chapter 20	
Thermal Stresses and Injuries	20-1
Chapter 21	
Toxicology	21-1
Chapter 22	
Emergency Escape from Aircraft	22-1
Chapter 23	
Aircraft Mishap Investigations	23-1
Chapter 24	
Aircraft Accident Survivability	24-1
Chapter 25	
Aircraft Accident Autopsies	25-1
Appendix A	
Historical Chronology of Aerospace Medicine in the U.S. Navy	A-1

CHAPTER 1

PHYSIOLOGY OF FLIGHT

The Atmosphere
Respiratory Physiology
Hypoxia
Hyperventilation
Positive Pressure Breathing
Cabin Pressurization
Rapid Decompression
Trapped Gas
Bubble Related Diseases
Oxygen Toxicity
Oxygen Equipment
References and Bibliography

The Atmosphere

The atmosphere of the Earth can be thought of as an ocean of gases which extend from the Earth's surface to space and is composed primarily of nitrogen, oxygen, argon and trace gases. The specific composition of the dry atmosphere is presented in Table 1-1. These fractional concentrations remain relatively constant to the outer limits of the atmosphere. Just as a column of water exerts a force or weight per unit area, the column of air above a specific point exerts a pressure (force), which usually is expressed in millimeters of mercury. Table 1-2 presents many of the units of pressure measurement in common use. This table includes both altitude measures and sea water depth measures. The relationship of pressure and temperature changes produced by the force of the column of air is presented in Table 1-3, from sea level to 100,000 feet, in both English and metric equivalents.

The atmosphere can be divided into several different concentric, spherical divisions based upon physical and chemical properties. DeHart (1985) and Campen (1960) identify principle characteristics of each of the atmospheric layers as illustrated in Figures 1-1, and described in Table 1-4.

Table 1-1
Composition of the Dry Atmosphere at Sea Level

Gas	Fractions Volume (% by volume)
Nitrogen	78.03
Oxygen	20.95
Argon	0.93
Carbon dioxide	0.03
Neon	1.82×10^{-3}
Helium	5.24×10^{-4}
Krypton	1.14×10^{-4}
Hydrogen	5.00×10^{-5}
Xenon	8.70×10^{-6}

Physiology of Flight

Table 1-2

Equivalent Pressures, Altitudes and Depths

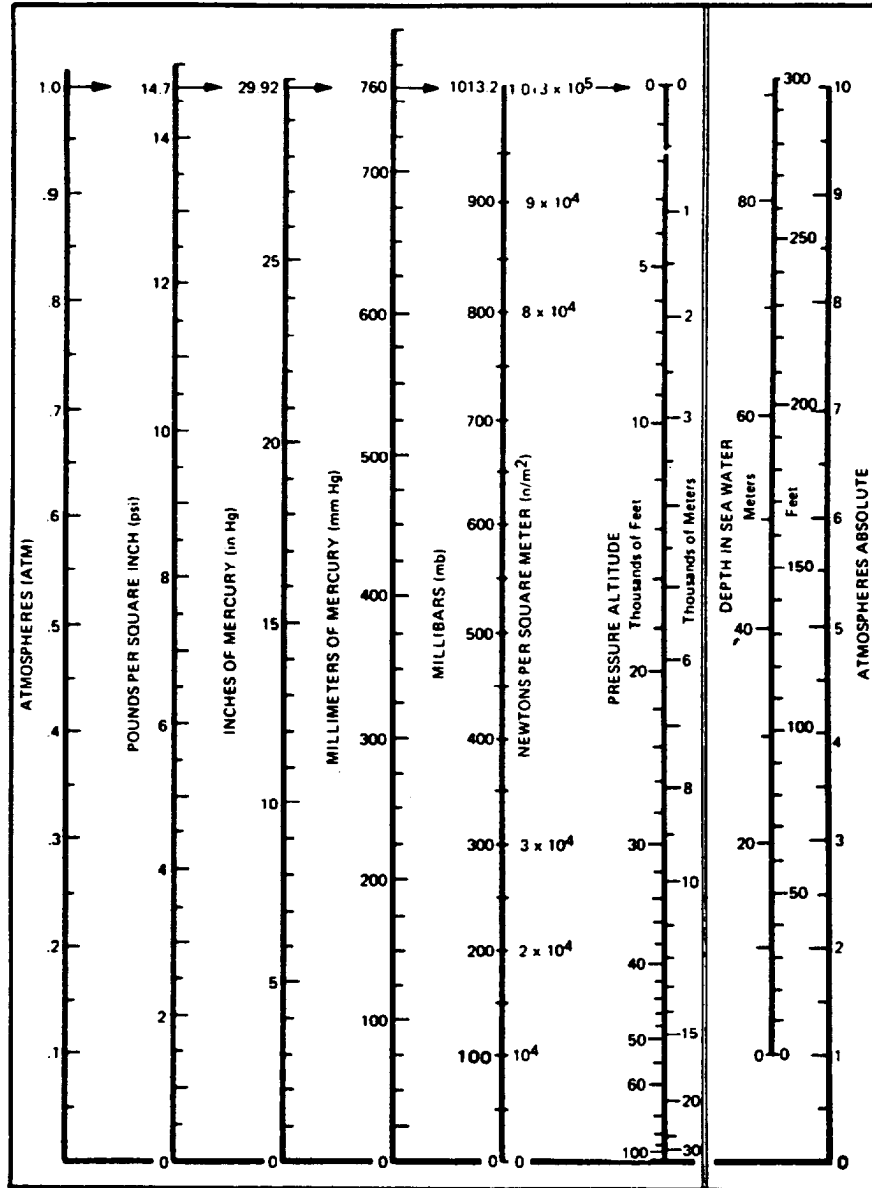

(Billings, 1973b).

Table 1-3

Altitude-Pressure-Temperature Relationships Based on the U.S. Standard Atmosphere

Altitude		Pressure		Temperature	
Feet x 10 ³	Meters	mm Hg	psi	F°	C°
0	0	760.0	14.7	59.0	15.0
1	304.8	732.9	14.2	55.4	13.0
2	609.6	706.7	13.7	51.9	11.0
3	914.4	681.2	13.2	48.3	9.1
4	1,219.2	656.4	12.7	44.8	7.1
5	1,524.0	632.4	12.2	41.2	5.1
6	1,828.8	609.1	11.8	37.6	3.1
7	2,133.6	586.5	11.3	34.0	1.1
8	2,438.4	564.6	10.9	30.5	-.8
9	2,743.2	548.4	10.5	26.9	-2.8
10	3,048.0	552.8	10.1	23.4	-4.8
11	3,352.8	502.8	9.7	19.8	-6.8
12	3,657.6	483.5	9.3	16.2	-8.8
13	3,962.4	464.8	9.0	12.7	-10.7
14	4,267.2	446.6	8.6	9.1	-12.7
15	4,572.0	429.1	8.3	5.5	-14.7
16	4,876.8	412.1	7.9	2.0	-16.7
17	5,181.6	395.7	7.7	-1.6	-18.7
18	5,486.4	379.8	7.3	-5.0	-20.6
19	5,791.2	364.4	7.0	-8.7	-22.6
20	6,096.0	349.5	6.8	-12.3	-24.6
21	6,400.8	335.2	6.5	-15.8	-26.6
22	6,705.6	321.3	6.2	-19.4	-28.5
23	7,010.4	307.9	5.9	-22.9	-30.5
24	7,315.2	294.9	5.7	-26.5	-32.5
25	7,620.0	282.4	5.5	-30.0	-34.5
26	7,924.8	270.3	5.2	-33.6	-36.5
27	8,229.6	258.7	5.0	-37.2	-38.4
28	8,533.4	247.4	4.8	-40.7	-40.4
29	8,839.2	236.6	4.6	-44.3	-42.4
30	9,144.0	226.1	4.4	-47.8	-44.4
31	9,448.8	216.1	4.2	-51.4	-46.3
32	9,753.6	206.4	3.9	-54.9	-48.3
33	10,058.4	197.0	3.8	-58.5	-50.3
34	10,363.2	187.9	3.6	-62.1	-52.3

Physiology of Flight

Table 1-3 (Continued)

Altitude-Pressure-Temperature Relationships Based on the U.S. Standard Atmosphere

Altitude		Pressure		Temperature	
Feet x 10 ³	Meters	mm Hg	psi	F°	C°
35	10,668.0	179.3	3.5	-65.6	-54.2
36	10,972.8	170.9	3.3	-69.2	-56.2
37	11,277.6	162.9	3.2	-69.7	-56.5
38	11,582.4	155.4	3.0	-	-
39	11,887.2	148.1	2.9	-	-
40	12,192.0	141.2	2.7	-	-
41	12,496.8	134.5	2.6	-	-
42	12,801.6	128.3	2.5	-	-
43	13,106.4	122.8	2.4	-	-
44	13,411.2	116.6	2.3	-	-
45	13,716.0	111.1	2.1	-	-
46	14,020.8	105.9	2.0	-	-
47	14,325.6	100.9	1.9	-	-
48	14,630.4	96.3	1.9	-	-
49	14,935.2	91.8	1.8	-	-
50	15,240.0	87.5	1.7	-	-
51	15,544.8	83.4	1.6	-	-
52	15,849.6	79.5	1.5	-	-
53	16,154.4	75.8	1.5	-	-
54	16,459.2	72.3	1.4	-	-
55	16,764.0	68.9	1.3	-	-
56	17,068.8	65.7	1.3	-	-
57	17,373.6	62.6	1.2	-	-
58	17,678.4	59.7	1.2	-	-
59	17,983.2	56.9	1.1	-	-
60	18,288.0	54.2	1.0	-	-
65	19,812.0	42.7	0.82	-69.7	-56.5
70	21,336.0	33.7	0.64	-67.3	-55.2
75	22,860.0	26.6	0.50	-64.5	-53.7
80	24,384.0	21.0	0.40	-61.8	-52.2
85	25,908.0	16.6	0.31	-59.4	-50.6
90	27,432.0	13.2	0.25	-56.4	-49.1
95	28,956.0	10.5	0.19	-53.5	-47.6
100	30,480.0	8.4	0.15	-50.8	-46.1

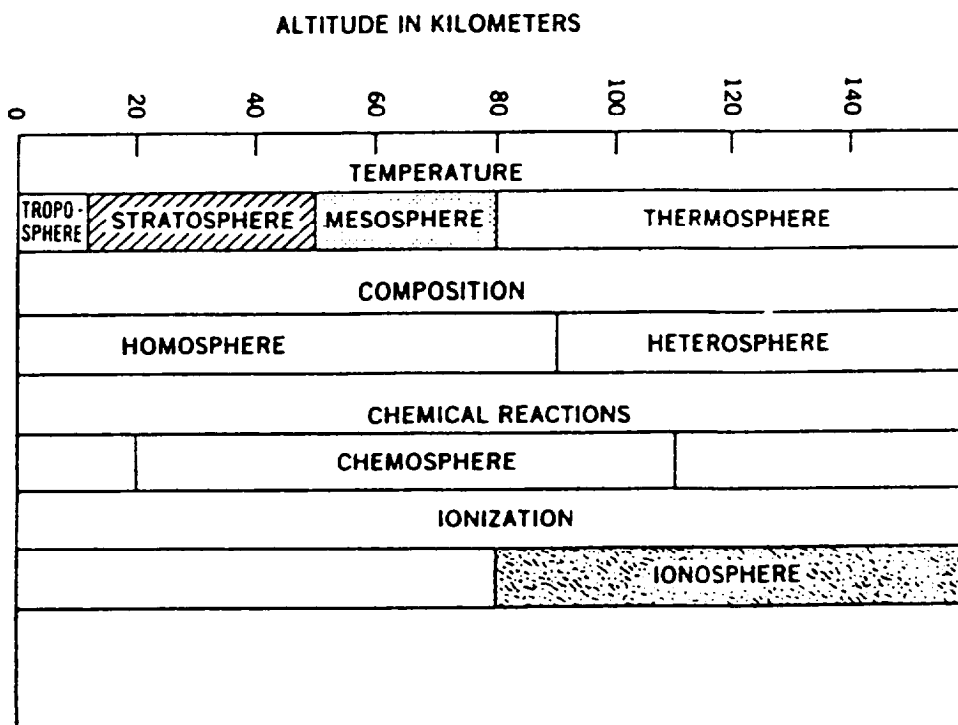

Figure 1-1. Identification of atmospheric shells (Ware, in DeHart, 1985).

Physiology of Flight

Table 1-4

Description of Atmospheric Shells

Temperature	
Name	Description
Troposphere	The region nearest the surface, which has a more or less uniform degree of temperature with altitude. The nominal rate of temperature decrease is 6.5 °K/km, but inversions are common. The troposphere, the domain of weather, is in convective equilibrium with the sun-warmed surface of the earth. The tropopause, which occurs at altitudes between 6 and 19 km (higher and colder over the equator), is the domain of high winds and highest cirrus clouds.
Stratosphere	The region next above the troposphere, which has a nominally constant temperature. The stratosphere is thicker over the poles and thinner, or even nonexistent, over the equator. The maximum of atmospheric ozone is found near the stratopause. Rare nacreous clouds are also found near the stratopause. The stratopause is about 25 km altitude in middle latitudes. Stratospheric temperatures are in the order of arctic winter temperatures.
Mesosphere	The region of the first temperature maximum. The mesosphere lies above the stratosphere and below the major temperature minimum, which is found near 80 km altitude and constitutes the mesopause. This is a relatively warm region between two cold regions, and the region where most meteors disappear. The mesopause is found at altitudes of from 70 to 85 km. The mesosphere is in radiative equilibrium between ultraviolet ozone heating by the upper fringe of the ozone region and the infrared ozone and carbon dioxide cooling by radiation to space.
Thermosphere	The region of rising temperature above the major temperature minimum around the altitude of 80 km. There is no upper altitude limit. This is the domain of the auroras. Temperature rises at the base of the thermosphere are attributed to too infrequent collisions among molecules to maintain thermodynamic equilibrium. The potentially enormous infrared radiative cooling by carbon dioxide is not actually realized owing to inadequate collisions.
Composition	
Homosphere	The region of substantially uniform composition, in the sense of constant mean molecular weight from the surface upward. The composition changes here primarily because of the dissociation of oxygen. Mean molecular weight decreases accordingly. The ozonosphere, having its peak concentration near the stratopause altitude, does not change the mean molecular weight of the atmosphere significantly.
Heterosphere	The region of significantly varying composition above the homosphere and extending indefinitely outward. The "molecular weight" of air diminishes from 29 at about 90 km to 16 at about 500 km. Well above the level of oxygen dissociation, nitrogen begins to dissociate, and diffusive separation (lighter atoms and molecules rising to the top) sets in.
Chemical Reactions	
Chemosphere	The region where chemical activity (primarily photochemical) is predominant. The chemosphere is found within the altitude limits of about 20 to 110 km.
Ionization	
Ionosphere	The region of sufficiently large electron density to affect radio communication. However, only about one molecule in 1000 in the F ₂ region to one molecule in 100,000,000 in the D region is ionized. The bottom of the ionosphere, the D region, is found at about 80 km during the day. At night the D region disappears, and the bottom of the ionosphere rises to 100 km. The top of the ionosphere is not well defined but has often been taken to be about 400 km. The upper limit has recently been extended upward to 100 km based on satellite and rocket data.

(DeHart , 1985)

Ozone (O_3) is produced in the upper atmosphere by the sun's radiation. Ozone is a highly toxic gas which significantly impacts respiratory functions. Significant concentrations are found between 40,000 and 140,000 feet as illustrated in Figure 1-2. This concentration of ozone is important in that it absorbs the majority of radiation in the ultraviolet range (wave lengths shorter than 2900 angstrom units), thereby screening potentially harmful radiation most often associated with skin cancer.

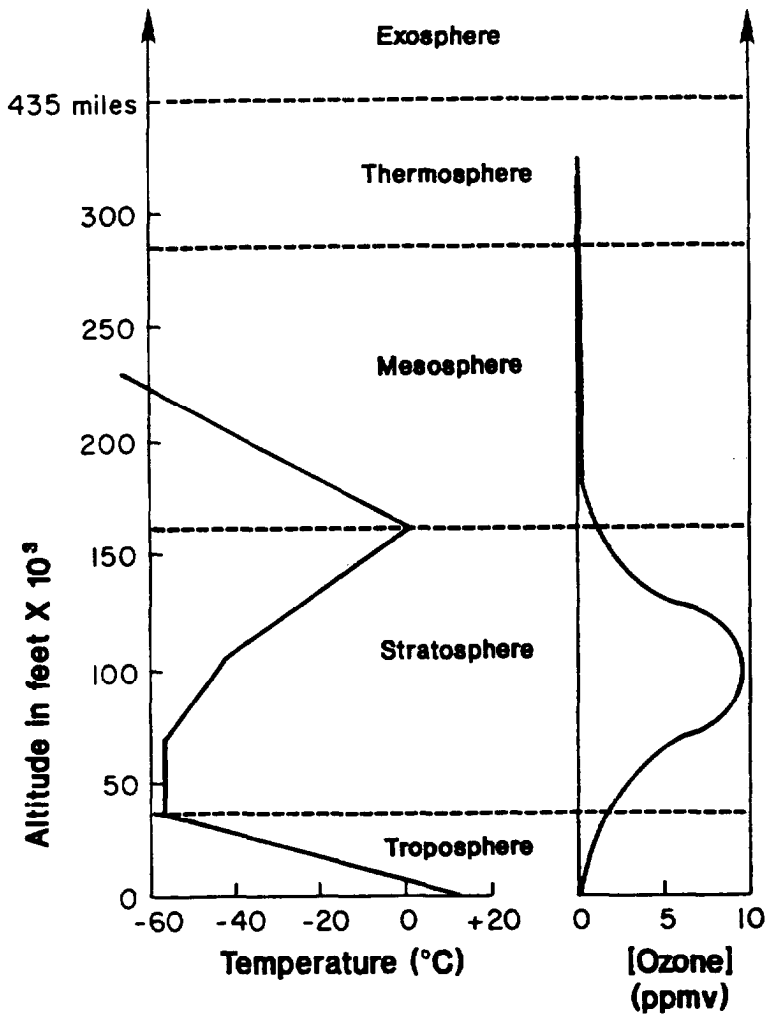

Figure 1-2. Relationship between temperature, altitude, and atmospheric zones.

Physiology of Flight

The characteristics and divisions of the atmosphere describe the physical features of the atmosphere. In the field of aerospace medicine it is man's physiological response to the environment which is of primary concern. Based on man's physiological responses, the atmosphere can be divided into three zones: the physiological zone, the physiologically deficient zone, and the space equivalent zone.

Physiological Zone

This zone extends from sea level to 10,000 feet. It is the zone to which man's body is well adapted. The oxygen level within this zone is sufficient to keep a normal, healthy individual physiologically fit without the aid of special protective equipment. The changes in pressure encountered with rapid ascents or descents within this zone can produce ear or sinus trapped gas problems; however, these are relatively minor when compared to the physiological impairments encountered at higher altitudes.

Physiologically Deficient Zone

This zone extends from 10,000 feet to 50,000 feet. Noticeable physiological deficits begin to occur above 10,000 feet. The decreased barometric pressure in this zone results in a sufficient oxygen deficiency to cause hypoxic hypoxia. Additional problems may also arise from trapped and evolved gases. Protective oxygen equipment is necessary in this zone.

Space Equivalent Zone

From a physiological viewpoint space begins when 50,000 feet is reached since supplemental 100 percent oxygen no longer protects man from hypoxia. The means of protecting an individual at 50,000 feet or above, are such that they will also protect him in true space (i.e., pressure suits and sealed cabins). The only additional physiological problems occurring within this zone, which extends from 50,000 feet to 120 miles, are possible radiation effects and the boiling of body fluids (ebullism) in an unprotected individual. Boiling of body fluids will occur when the total barometric pressure is less than the vapor pressure of water at 37° C [47 millimeters of mercury (mm Hg)] which is reached at an altitude of 63,500 feet (Armstrong's Line).

Respiratory Physiology

Gas physiology is one of the cornerstones of aviation medicine. A great deal of work has been done in this field in connection with high-altitude military and civilian aircraft development as well as in support of manned space flight. The purpose of this chapter is not to present a compen-

dium of this information but rather a skeleton upon which an interested flight surgeon may build through additional reading.

The four principal gases of interest in aviation medicine are oxygen, nitrogen, carbon dioxide, and water vapor.

The principal functions of respiration are to transport alveolar oxygen to the tissues and to transport tissue carbon dioxide back to the lungs. The process is effected by transporting gases through the upper respiratory tract and trachea to the alveoli, letting the gases of alveoli and pulmonary capillary blood reach equilibrium with each other, transporting the arterial blood to tissue, where tissue gases reach equilibrium with arterial gases in the capillaries, and returning the blood to the lungs to repeat the process.

Individual cells within the tissues of the body are basically fluid in composition and, as such, are essentially incompressible. Pressure applied uniformly to a tissue surface thus is readily transmitted throughout the tissue and to adjoining structures. Changes in the pressure environment do not produce cellular distortion but instead simply change the pressure of gases contained within the body. The manner in which changes in gas pressure affect the body can be expressed in terms of the classic laws of gas mechanics.

Classic Laws of Gas Mechanics

Boyle's Law. Boyle's Law states that the volume of a gas is inversely proportional to its pressure, temperature remaining constant. This means that at 18,000 feet, where the pressure is approximately half that of sea level, a given volume of gas will attempt to expand to twice its initial volume in order to achieve equilibrium with the surrounding pressure.

Charles' Law. Charles' Law states that the pressure of a gas is directly proportional to its absolute temperature, volume remaining constant. The contraction of gas due to temperature change at altitude, however, in no manner compensates for the expansion due to the corresponding decrease in pressure.

Dalton's Law. Dalton's Law of partial pressures states that each gas in a mixture of gases behaves as if it alone occupied the total volume and exerts a pressure, its partial pressure, independent of the other gases present. The sum of the partial pressures of individual gases is equal to the total pressure. Using this law, one can calculate the partial pressure of a gas in a mixture simply by knowing the percentage of concentration in that mixture.

Physiology of Flight

Henry's Law. Henry's Law states that the amount of gas in a solution varies directly with the partial pressure of that gas over the solution.

Graham's Law. Graham's Law states that the relative rates of diffusion of gases under the same conditions of temperature and pressure are inversely proportional to the square roots of the densities of those gases. Gases with smaller molecular weights will diffuse more rapidly..

Pulmonary Ventilation

Ventilation is a cyclic process by which fresh air or a gas mixture enters the lungs and pulmonary air is expelled. The inspired volume is greater than the expired volume because the volume of oxygen absorbed by the blood is greater than the volume of carbon dioxide, which is released from the blood. Since gas exchange occurs solely in the alveoli and not in the conducting airways, the estimation of alveolar ventilation rate (i.e., the amount of gas which enters the alveoli per minute) is the most important single variable of ventilation.

Pulmonary ventilation does not occur evenly throughout the alveoli since normal lungs do not behave like perfect mixing chambers, nor is the pulmonary capillary network evenly distributed throughout the lungs. Ventilation, therefore, must be readjusted regionally to match the increased or decreased blood flow, or some of the alveoli will be relatively under or over ventilated. The even distribution of pulmonary capillary blood flow is as important as an even distribution of inspired air to the alveoli for normal oxygenation of the blood.

Gaseous Diffusion

Respiratory gas exchange in the lungs is accomplished entirely by the process of simple diffusion. The direction and amount of movement of the molecules depend upon the difference in partial pressure on both sides of the alveolar membrane. Normally, molecular oxygen moves from a region of higher partial pressure to one of lower partial pressure. The volume of gas which can pass across the alveolar membrane per unit time at a given pressure is the diffusing capacity of the lungs.

The diffusing capacity is not only dependent on the difference in partial pressure of the gas in the alveolar air and pulmonary capillary blood, but it is also proportional to such factors as the effective surface area of the pulmonary vascular bed. It is inversely proportional to the average thickness of the alveolar membrane and directly proportional to the solubility of the gas in the membrane. The normal values for diffusing capacity range from 20 to 30 ml O₂/min/mm Hg for normal young adults.

Pulmonary Capillary Blood Flow

Pulmonary capillary blood flow must be adequate in volume and well distributed to all of the ventilated alveoli to insure proper gas exchange. Underperfused or poorly ventilated alveoli can become a serious matter during flight when G forces acting on the body result in a redistribution of pulmonary capillary blood flow. During exposure to positive (+ G_z) accelerative forces, the blood flow is directed to the lung bases, whereas, during exposure to negative (- G_z) acceleration, the flow is toward apical areas.

Composition of Respired Air

The composition of the atmosphere is remarkably constant between sea level and an altitude of 300,000 feet. Nitrogen and oxygen are the most abundant gases in the atmosphere as shown in Table I-1. From a practical standpoint, in the study of the effects of altitude on the human body, the percent concentrations of the other gases are considered negligible and are ignored. It is convenient, therefore, to consider air as about four fifths (79 percent) nitrogen and one fifth (21 percent) oxygen.

Atmospheric Air

In the dry air at sea level, the partial pressures of the constituent gases according to Dalton's Law are:

$$PO_2 = 760 \text{ mm Hg} \times 0.2075 = 157.7 \text{ mm Hg}$$

$$PN_2 = 760 \text{ mm Hg} \times 0.7902 = 600.6 \text{ mm Hg}$$

$$PCO_2 = 760 \text{ mm Hg} \times 0.003 = 0.2 \text{ mm Hg}$$

Tracheal Air

When inspired air enters the respiratory passages, it rapidly becomes saturated with water vapor and is warmed to body temperature. The water vapor has a constant pressure of 47 mm Hg at the normal body temperature of 98.6° F, regardless of the barometric pressure. Accordingly, the sum of the partial pressures of the inspired gases no longer equals the barometric pressure, but instead equals the barometric pressure minus the water vapor pressure. Thus, the tracheal partial pressure of inspired gases can be calculated as follows:

$$P_{tr} = (P_B - 47) \times F_I$$

Physiology of Flight

where

P_{tr} = The tracheal partial pressure of the inspired gas

P_B = Barometric pressure

F_I = The fractional concentration of the inspired gas.

Aveolar Air

The theoretical alveolar (alv) PO_2 for any altitude can be calculated if one knows the barometric pressure and the dry fraction (percentage) of oxygen in the inhaled gas. A constant, sea level ventilation rate and a normal metabolic rate are presumed for the sake of simplicity. With tracheal (tr) P_{H_2O} a constant 47 mm Hg, PCO_2 (alv) a constant 40 mm Hg, a barometric pressure at 10,000 feet of 523 mm Hg, and a dry fraction of oxygen of 21 percent, then at 10,000 feet breathing air,

$$PO_2(tr) = (P_B - P_{H_2O}[tr]) \times .21 \text{ or}$$
$$PO_2(tr) = .21 (523-47) = 99.96 \text{ mm Hg.}$$

However, in the transition from tracheal gas to alveolar gas, the PO_2 is reduced and PCO_2 is increased. The P_{N_2} remains the same. Therefore,

$$PO_2(alv) = PO_2(tr) - PCO_2(alv)$$
$$PO_2(alv) = 99.96 \text{ mm Hg} - 40 \text{ mm Hg} = 60 \text{ mmHg}.$$

Actual measurements of $PO_2(alv)$ at various altitudes derived from both breathing air and breathing 100 percent oxygen are presented in Table 1-5. The $PO_2(alv)$ at 10,000 feet breathing air was measured to be 61 mm Hg. This drop in PO_2 with ascent causes a gradually increasing hypoxic stimulus to respiration (via the chemoreceptors in the area of the carotid sinus) resulting in an increased respiratory exchange rate (RER) and an increased $PO_2(alv)$ over that calculated. There also is a decreased $PCO_2(alv)$. Table 1-5 can be used for calculations when measured data are not available.

Table 1-6 shows measured changes at sea level in the partial pressure of the gases at various sites in the respiratory cycle. This is illustrated graphically for oxygen and carbon dioxide in Figure 1-3.

Table 1-5

Tracheal Oxygen Pressure, Alveolar Oxygen Pressure, and Carbon Dioxide Pressure in the Alveolar Gas When Breathing Air and 100 Percent Oxygen at Physiologically Equivalent Altitudes

Breathing air					Breathing oxygen (100 percent)					
Altitude	Baro- metric pressure	Tracheal Po ₂	Alveolar		RER*	Altitude	Baro- metric pressure	Tracheal Po ₂	Alveolar	
			Po ₂	Pco ₂					Po ₂	Pco ₂
<i>Feet</i>	<i>mm of Hg</i>	<i>mm of Hg</i>	<i>mm of Hg</i>	<i>mm of Hg</i>		<i>Feet</i>	<i>mm of Hg</i>	<i>mm of Hg</i>	<i>mm of Hg</i>	<i>mm of Hg</i>
Sea level	760	149	103	40	0.85	33,000	196	149	109	40
5,000	632	122	79	38	0.87	36,000	170	123	85	38
10,000	523	100	61	36	0.90	39,000	148	100	64	36
15,000	429	80	46	33	0.95	42,000	128	81	48	33
20,000	349	63	33	30	1.00	45,000	111	64	34	30
22,000	321	57	30	28	1.05	46,000	106	59	30	29

*Respiratory exchange rate (Luft, 1961).

Physiology of Flight

Table 1-6

Partial Pressures of Respiratory Gases at Various Sites in Respiratory Circuit of Man at Rest at Sea Level

Sample	Gas partial pressure				
	O ₂ mm Hg	CO ₂ mm Hg	N ₂ mm Hg	H ₂ ^o mm Hg	Total mm Hg
Inspired air	158	0.3	596	5.7	760
Expired air	116	32.0	565	47.0	760
Alveolar air	100	40.0	573	47.0	760
Arterial blood	100	40.0	573	47.0	760
Venous blood	40	46.0	573	47.0	706
Tissues	30	50.0	573	47.0	700
	or less	or more			

(Carlson, 1965a.)

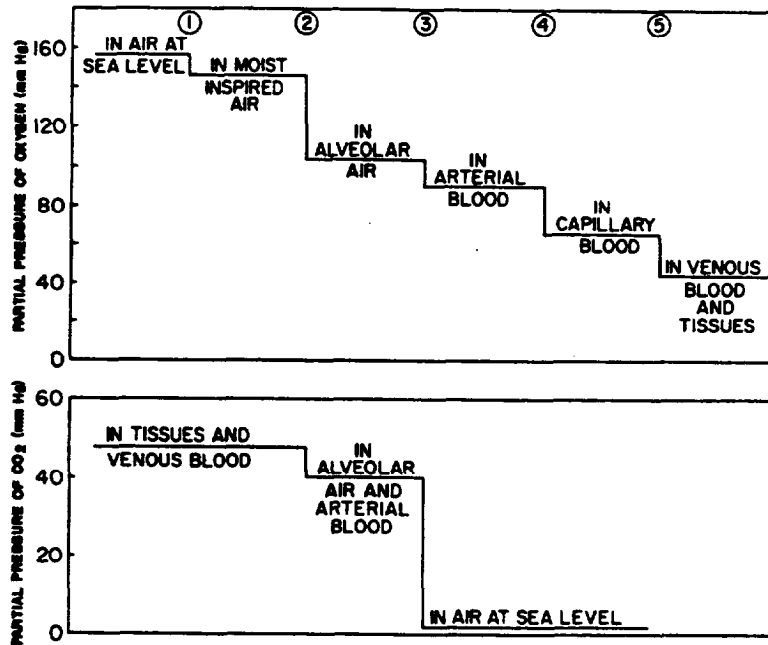

Figure 1-3. Partial pressures of O₂ (above) and CO₂ (below) in air at sea level and at various points within the body (Billings, 1973a).

Oxygen Transport

Oxygen is carried in the blood both in simple physical solution and in loose chemical combination with hemoglobin in the form of oxyhemoglobin. The oxygen transport capacity of one gram of hemoglobin is 1.34 ml of oxygen. Therefore, the capacity for 100 ml of blood is about 20 ml of oxygen (presuming normal hemoglobin to be 14.7 gm/100 ml) and represents 100 percent hemoglobin saturation. Normally, arterial hemoglobin in an individual breathing air at sea level is 98 percent saturated. When breathing 100 percent oxygen at sea level pressure, the hemoglobin becomes 100 percent saturated, and additional oxygen goes into simple solution in the plasma. The total of additional oxygen so transported is 11 percent greater than normal.

In Figure 1-4, a family of oxygen-hemoglobin dissociation curves is presented. From these curves it can be seen that the blood leaves the pulmonary capillary bed with the hemoglobin about 98 percent saturated. Even if the $PO_2(\text{alv})$ is reduced by 20 mm Hg, the saturation is reduced by only three to four percent. In the tissue capillaries, however, a small decrease in oxygen tension causes changes in the dissociation curve which result in a large quantity of oxygen being made available to the tissues. The upper section of the dissociation curves (Figure 1-4A) remains relatively flat through an oxygen tension change of 40 mm Hg; thus, when the $PO_2(\text{alv})$ falls from 100 to 60 mm Hg the blood saturation is reduced only by about eight percent. As the oxygen tension continues to fall, however, an additional reduction of 30 mm Hg results in a precipitous drop in blood saturation to 58 percent. Thus, the characteristic shape of the dissociation curves accounts for the relatively mild effects of hypoxia at low altitude and the very serious impairment of function at higher altitudes.

The oxygen carrying capacity of the blood hemoglobin is also very sensitive to changes in blood pH (Bohr effect), as illustrated in Figure 1- 4B. At an oxygen tension of 60 mm Hg, for example, at pH 7.2, 7.4, and 7.6, the arterial oxygen saturation is observed to be 84, 89 and 94 percent, respectively. Carbon dioxide is the major determinant of blood pH. In venous blood PCO_2 is high; accordingly, the pH is low. In arterial blood, the PCO_2 is less as a result of the diffusion of carbon dioxide into the alveoli. The arterial blood, therefore, has a higher pH and can carry more oxygen at a given alveolar PO_2 that would be possible without this change in pH. In the tissues, the reverse conditions exists.

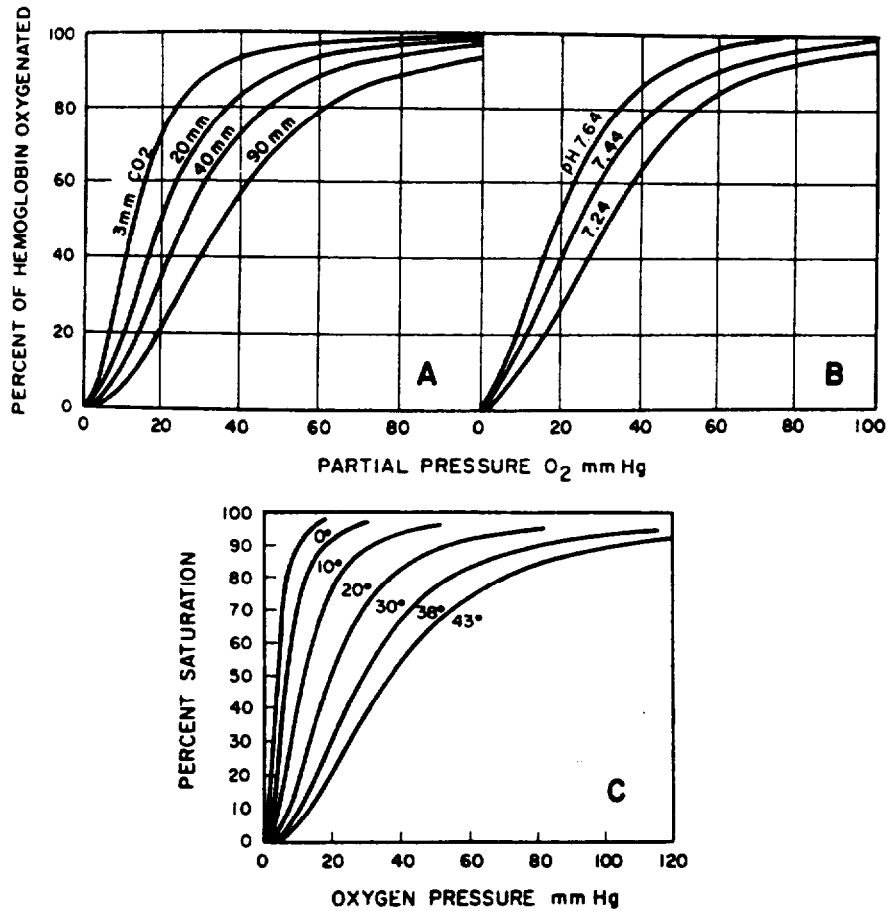

Figure 1-4. A. Effect of CO₂ on oxygen dissociation curve of whole blood (after Barcroft). B. Effect of acidity on oxygen dissociation curve of blood (after Peters & Van Slyke). C. Effect of temperature on oxygen dissociation curve of blood (Carlson, 1956b).

Control of Respiration

The neural control of respiration is accomplished by neurons in the reticular formation of the medulla. This rhythmic activity is modified by afferent impulses arising from receptors in various parts of the body, by impulses originating in higher centers of the central nervous system, and by specific local effects induced by changes in the chemical composition of the blood.

A major decrease in arterial PO₂ causes slightly increased pulmonary ventilation. However, if the afferent fibers from the chemoreceptive areas are severed, respiration is depressed. Thus, the

direct effect of hypoxia on the respiratory center itself is depressive, but hypoxia will cause increased pulmonary ventilation when the chemoreceptor mechanism is intact.

A minute increase of about 0.25 percent alveolar carbon dioxide will lead to a 100 percent increase in pulmonary ventilation rate. Conversely, lowering the alveolar PCO_2 by voluntary hyperventilation tends to produce apnea. From these observations, it may be deduced that control of respiration appears to be governed primarily by the homeostasis of alveolar PCO_2 .

Oxygen lack is a rather ineffective stimulus for pulmonary ventilation. Ernsting (1965b) reports that no increase in pulmonary ventilation occurs with acute oxygen lack until the alveolar PO_2 is reduced to about 65 mm Hg, or at approximately 37,000 to 39,000 feet equivalent altitude, breathing 100 percent oxygen. Even a reduction alveolar oxygen to about 40 mm Hg (42,000 feet equivalent altitude) will only increase ventilation by about one third of its normal resting value. The pattern of pulmonary ventilation occurring in hypoxia does not represent a simple reaction to the reduced alveolar oxygen tension.

Hypoxia

Probably the most frequently encountered hazard in aviation medicine is hypoxia. Records of early balloon and aircraft flights describe tragedies resulting from hypoxia, since even these primitive machines had a higher operational ceiling than the men aboard them.

Hypoxia was a serious aviation problem in both World Wars and remains a potential threat even in today's military aviation. Engineering solutions to the problem have been ingenious. Considerable money has been expended on training of aviators and on procurement of equipment to prevent hypoxia. Yet, hypoxic incidents continue to occur, and the flight surgeon should be well informed concerning this problem.

There is a commonly encountered misconception among aviators that it is possible to learn all of the early symptoms of hypoxia and then to take corrective measures once symptoms are noted. This concept is appealing because it allows all action, both preventive and corrective, to be postponed until the actual occurrence.

Unfortunately, the theory is both false and dangerous. One of the earliest effects of hypoxia is impairment of judgment. Therefore, even if the early symptoms are noted, an aviator may disregard them and often does, or he may take corrective action which is actually hazardous, such as disconnecting himself from his only oxygen supply. Finally, at high altitudes, hypoxia may cause unconsciousness as the first symptom.

Physiology of Fight

These factors must be kept in mind during a flight surgeon's study of hypoxia, during the indoctrination and refresher training flights in the altitude chamber at an Aviation Physiology Training Unit, and especially during the flight surgeon's daily contact with aviators in the ready room, sickbay, or clinic.

Despite improvements in oxygen delivery systems, more reliable cabin pressurization systems, and extensive physiology training, hypoxia still remains ever present in today's military aviation. Each year, approximately 8 to 10 physiological episodes of hypoxia are reported. The most common cause of the hypoxic incident is cabin or cockpit pressurization failure followed by defective oxygen equipment. In these incidents, the pilot or copilot was able to recover the aircraft and avoid a major mishap or fatality. One can only conjecture how many mishaps and fatalities in military aviation have occurred as the direct result of hypoxia. Since hypoxia episodes are still frequently encountered, and in all likelihood contribute to many major mishaps and fatalities, the flight surgeon and aviation physiologist should be well informed of every facet of the problem.

Types of Hypoxia

The amount and pressure of oxygen delivered to the tissues is determined by arterial oxygen saturation, by the total oxygen-carrying capacity, and by the rate of delivery to the tissues. Hypoxia, defined as an insufficient supply of oxygen, can result from any one of these factors. Accordingly, the following classic types of hypoxia have been distinguished:

1. *Hypoxic hypoxia* results from an inadequate oxygenation of the arterial blood and is caused by reduced oxygen partial pressure.
2. *Anemic hypoxia* results from the reduced oxygen-carrying capacity of the blood, which may be due to blood loss, any of the anemias, carbon monoxide poisoning, or by drugs causing methemoglobinemia.
3. *Stagnant hypoxia* is caused by a circulatory malfunction which results, for example, from the venous pooling encountered during acceleration maneuvers.
4. *Histotoxic hypoxia* results from an inability of the cells to utilize the oxygen provided when the normal oxidation processes have been poisoned such as by cyanide. There is no oxygen lack in the tissues, but rather an inability to use available oxygen, with the result that the PO_2 in the tissues may be higher than normal. Therefore, it is not true hypoxia by the definition used here.

The most common type of hypoxia encountered in aviation is hypoxic hypoxia. This results from the reduced oxygen partial pressure in the inspired air caused by the decrease in barometric pressure. Other types may also affect aircrewmembers, such as anemic hypoxia as seen in carbon monoxide poisoning and stagnant hypoxia resulting during various acceleration profiles.

Types of Onset of Hypoxia

The onset of hypoxia varies with the cause. During ascent to altitude without supplementary oxygen equipment, the onset of hypoxia is as gradual as the rate of ascent. As soon as an inspiration is completed, the alveolar gases approach equilibrium with the inspired gases, and similarly, the arterial gases reach a very rapid equilibrium with the alveolar gases, but the change in barometric pressure is gradual between breaths.

In the event of contamination or dilution of oxygen in the mask with some amount of cabin air, due to either a leaky mask or faulty tubing, onset of hypoxia is intermittent. Moreover, the effects are inconsistent because the amount of hypoxia developing varies from one breath to the next, depending on leakage rate, altitude, and body position (which may cause the aperture of a leak to be temporarily closed, partially open, or completely open). This type of hypoxia onset is difficult to trace because it is often difficult to validate that a hypoxic incident occurred, much less to determine the cause.

In the case of a supply hose disconnect or other cause of exposure to ambient air, whether known or unknown, the onset of symptoms will be determined by the altitude during exposure. If such a disconnect is immediately discovered, and if no decompression is involved, the aircrewmembers should hold his breath while attempting to reconnect, because the alveolar PO_2 is higher than the ambient PO_2 . Breathing in such circumstances will cause a washout of oxygen from the tissues. This must be avoided as long as possible.

When rapid decompression occurs, the volume and pressure of alveolar gases become markedly higher than those of the ambient atmosphere, and sudden expulsion of the alveolar gases occurs. At the end of the resulting involuntary expiration, the normal reaction is to inhale, and at the end of that inspiration, the alveolar PO_2 is in equilibrium with the ambient air. The resulting effects will depend upon the PO_2 at the terminal decompression altitude.

Symptomatology

Many observations have been made on the subjective and objective symptoms of hypoxia. A detailed analysis of progressive functional impairment indicates that the effects of hypoxia fall in-

Physiology of Plight

to four stages. Table 1-7 summarizes the stages of hypoxia in relation to the altitude of occurrence, breathing air or breathing 100 percent oxygen, and the arterial oxygen saturation.

Table 1-7

Stages of Hypoxia

Stage	Altitude in feet		Arterial oxygen saturation (percent)
	Breathing air	Breathing 100 percent O ₂	
Indifferent	0-10,000	33,000-39,000	95-90
Compensatory	10,000-15,000	39,000-42,200	90-80
Disturbance	15,000-20,000	42,200-45,200	80-70
Critical	20,000-23,000	45,200-46,800	70-60

1. *Indifferent Stage.* There is no observed impairment. The only adverse effect is on dark adaptation, emphasizing the need for oxygen use from the ground up during night flights.

2. *Compensatory State.* The physiological adjustments which occur in the respiratory and circulatory systems are adequate to provide defense against the effects of hypoxia. Factors such as environmental stress or prolonged exercise can produce certain decompensations. In general, in this stage there is an increase in pulse rate, respiratory minute volume, systolic blood pressure, and cardiac output. There is also an increase in fatigue, irritability, and headache, and a decrease in judgment. The individual has difficulty with simple tests requiring mental alertness or moderate muscular coordination.

3. *Disturbance Stage.* In this stage, physiologic responses are inadequate to compensate for the oxygen deficiency, and hypoxia is evident. Subjective symptoms may include headache, fatigue, lassitude, somnolence, dizziness, "air-hunger", and euphoria. At 20,000 feet, the period of useful consciousness is 15 to 20 minutes. In some cases, there are no subjective symptoms noticeable up to the time of unconsciousness. Objective findings include:

a. *Special Senses.* Peripheral and central vision are impaired and visual acuity is diminished. There is weakness and incoordination of the extraocular muscles and reduced range of accom-

modation. Touch and pain sense are lost. Hearing is one of the last senses to be affected.

b. *Mental Processes.* The most striking symptoms of oxygen deprivation at these altitudes are classed as psychological. These are the ones which make the problem of corrective action so difficult. Intellectual impairment occurs early, and the pilot has difficulty recognizing an emergency situation unless he is widely experienced with hypoxia and has been very highly trained. Thinking is slow; memory is faulty; and judgment is poor.

c. *Personality Traits.* In this state of mental disturbance, there may be a release of basic personality traits and emotions. Euphoria, elation, moroseness, pugnaciousness, and gross overconfidence may be manifest. The behavior may appear very similar to that noted in alcoholic intoxication.

d. *Psychomotor Functions.* Muscular coordination is reduced and the performance of fine or delicate muscular movements may be impossible. As a result, there is poor handwriting, stammering, and poor coordination in flying. Hyperventilation is noted and cyanosis occurs, most noticeable in the nail beds and lips.

4. *Critical Stage.* In this stage of acute hypoxia, there is almost complete mental and physical incapacitation, resulting in rapid loss of consciousness, convulsions, and finally in failure of respiration and death.

An important factor in the sequence cited above is the gradual ascent to altitude where the individual can come to equilibrium with the gaseous environment, and physiological adjustments have sufficient time to come into play. This occurs in military aviation only in cases where the aviator is unaware that his oxygen is disconnected or in cases where leaks occur in the oxygen system, causing gradual dilution of the oxygen with cabin air.

Of greatest concern to a flight surgeon is hypoxia resulting from the sudden loss of cabin pressure in aircraft operating at very high altitudes. Under these conditions, a loss of pressurization or oxygen supply will cause exposure of the aviator to environmental conditions so stressful that physiological compensation cannot occur before the onset of unconsciousness.

Time of Useful Consciousness

The time of useful consciousness is that period between an individual's sudden deprivation of oxygen at a given altitude and the onset of physical or mental impairment which prohibits his taking rational action. It represents the time during which the individual can recognize his problem

Physiology of Flight

and reestablish an oxygen supply, initiate a descent to lower altitude, or take other corrective action. Time of useful consciousness is also referred to as effective performance time (EPT).

The time of useful consciousness is primarily related to altitude, but it is also influenced by individual tolerances, physical activity, the way in which the hypoxia is produced and the environmental conditions prior to the exposure. Average times of useful consciousness at rest and with moderate activity at various altitudes are shown in Table 1-8. The subjects were breathing oxygen and produced the hypoxic environments by disconnecting their masks. If an individual breathing air is suddenly decompressed, his time of useful consciousness is shorter than if he had been breathing oxygen (Figure 1-5). The PO_2 in his lungs drops immediately to a level dependent only on the final altitude, rather than dropping gradually with each breath of air, dependent on lung volume, dilution of that volume, and altitude.

Table 1-8

Time of Useful Consciousness

Altitude (1,000 feet)	Rapid disconnect (moderate activity)	Rapid disconnect (sitting quietly)
22.....	5 minutes	10 minutes.
25.....	2 minutes	3 minutes.
28.....	1 minute	1 minute 30 seconds.
30.....	45 seconds	1 minute 15 seconds.
35.....	30 seconds	45 seconds.
40.....	18 seconds	30 seconds.
65.....	12 seconds	12 seconds.

(Carlyle, 1963).

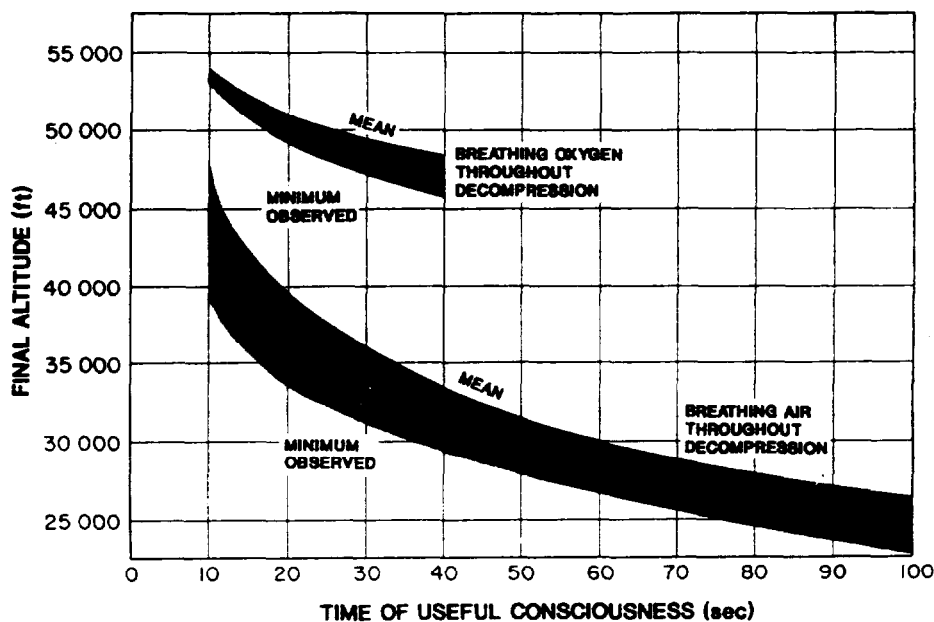

Figure 1-5. Minimum and average duration of effective consciousness in subjects following rapid decompression breathing air (lower curve) and O₂ (upper curve) (Billings, 1973a; data from Blockley & Hanifan, 1961).

Limit Altitudes and Altitude Equivalentents

In considering hypoxia, some minimum limit must be set on the supply of oxygen considered 'adequate' for the purposes of military aviation. Ideally, one would select sea level conditions as the limit and design and construct oxygen supply systems to maintain them, but this is not feasible considering the altitudes at which Navy and Marine Corps aircraft are capable of operating.

In determining a limit altitude, one is actually specifying the maximum level of hypoxia which is acceptable. The Navy NATOPS Manual, General Flight and Operating Instructions, OPNAV Instruction 3710.7 series, specifies the following limit altitudes for crew members aboard naval aircraft: With one exception, all occupants aboard naval aircraft will use supplemental oxygen on flights in which the cabin altitude exceeds 10,000 feet.

Exception: When all occupants are equipped with oxygen, unpressurized aircraft may ascend to flight level 250 (25,000 feet). When minimum enroute altitudes or an ATC clearance requires flight above 10,000 feet in an unpressurized aircraft, the pilot at the controls shall use oxygen.

Physiology of Flight

When oxygen is not available to other occupants, flight between 10,000 and 13,000 feet shall not exceed three hours duration, and flight above 13,000 feet is prohibited.

Table 1-9 gives the oxygen requirements for pressurized aircraft flown above 10,000 feet, when cabin altitude is maintained at 10,000 feet or less. The quantity of oxygen aboard an aircraft before takeoff must be sufficient to accomplish the planned mission. In aircraft carrying passengers, there must be an adequate quantity of oxygen to protect all occupants through normal descent to 10,000 feet.

Table 1-9

Oxygen Requirements for Pressurized Aircraft Other Than Jet Aircraft

AMBIENT ALTITUDE	SINGLE-PILOTED AIRCRAFT	MULTIPILOTED AIRCRAFT		CREW ON DUTY	OTHER OCCUPANTS
		PILOT	COPILOT		
FL 270 and below	R	R	R	R	N/A
Above FL 270 through FL 350	I	I	R	R	R
Above FL 350 through FL 400	O	I or O	I or R	R	R
Above FL 400 through FL 450	O	O	I	R	R
Above FL 450 through FL 500	O	O	I	I	I
Above FL 500	P	P	P	P	P

Legend:

R — Oxygen shall be readily available.

I — Oxygen shall be immediately available. Helmets shall be worn with an oxygen mask attached to one side or an approved quick-donning or sweep-on mask properly adjusted and positioned for immediate use. Set oxygen regulator to 100 percent and ON.

O — Oxygen shall be used.

P — Pressure suit shall be worn

Note

In multipiloted pressurized aircraft if above FL 270, the pilot at the controls must be using 100% oxygen if the other seat is occupied by other than a qualified pilot.

If loss of pressurization occurs, a descent shall be made immediately to a flight level where cabin altitude can be maintained at, or below, 25,000 feet, and oxygen shall be utilized by all occupants.

When it is observed or suspected that an occupant of any aircraft is suffering the effects of decompression sickness, 100 percent oxygen will be started and the pilot shall immediately descend and land at the nearest civilian or military installation, and obtain qualified medical assistance. The person affected may continue the flight only on the advice of a flight surgeon.

In tactical jet and tactical jet training aircraft, oxygen shall be used by all occupants from takeoff to landing. Emergency bailout bottles, when provided, shall be connected prior to flight.

Respiratory Adjustments to Altitude

The critical $PO_2(\text{alv})$ at which the average individual loses consciousness on short exposure to altitude is 30 mm Hg. This corresponds to 23,000 to 25,000 feet on Curve A of Figure 1-6. In the complete absence of respiratory adjustments to altitude, the same $PO_2(\text{alv})$ would be encountered at about 17,000 feet.

Applying similar considerations to 100 percent oxygen breathing altitudes, it is evident that hypoxia-induced hyperventilation, as reflected in the course of the $PCO_2(\text{alv})$ on Curve D of Figure 1-6, does improve the $PO_2(\text{alv})$ measurably. Thus, the 30 mm Hg $PO_2(\text{alv})$ in this case is at 47,000 feet (Curve C) with respiratory adjustment and 44,000 feet without it.

Comparisons can be made between different barometric pressures which produce the same alveolar PO_2 when breathing air in one case and 100 percent oxygen in the other, in order to establish "physiologically equivalent altitudes." Actually, physiological states cannot be compared solely on the basis of $PO_2(\text{alv})$. $PCO_2(\text{alv})$ and ventilation must be considered also, since a change in one will cause change in the others until a steady state is reached.

Physiology of Flight

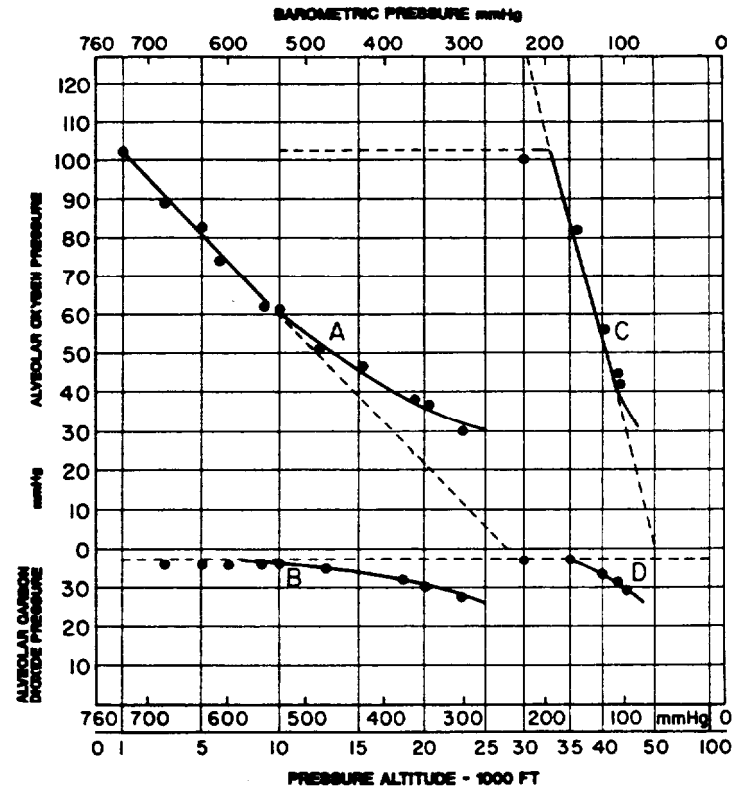

Figure 1-6. The partial pressures of respiratory gases when breathing air (A, oxygen; B, carbon dioxide) and using oxygen equipment (C, oxygen; D, carbon dioxide). The interrupted lines represent the theoretical course in the absence of the respiratory response to hypoxia at altitude (Boothby, Lovelace, Benson & Strehler, 1954).

The time necessary to reach a steady state at various altitudes is given in Figure 1-7. Note that even at the relatively low altitude of 18,000 feet, a steady state is reached only after an hour of respiratory adjustment. For practical purposes, the $PO_2(\text{alv})$ may be used without considering respiratory adjustment in establishing physiologically equivalent altitudes.

Ten thousand feet during daylight is specified as the limit above which, in non-pressurized aircraft, crew members must use oxygen. The $PO_2(\text{alv})$ at 10,000 feet, breathing air, is approximately 61 mm Hg, which produces the maximum acceptable degree of hypoxia which Navy and Marine Corps aircrewmembers are allowed to undergo. As a consequence, all oxygen equipment and barometric controls are designed to maintain the user at this physiological equivalent or below.

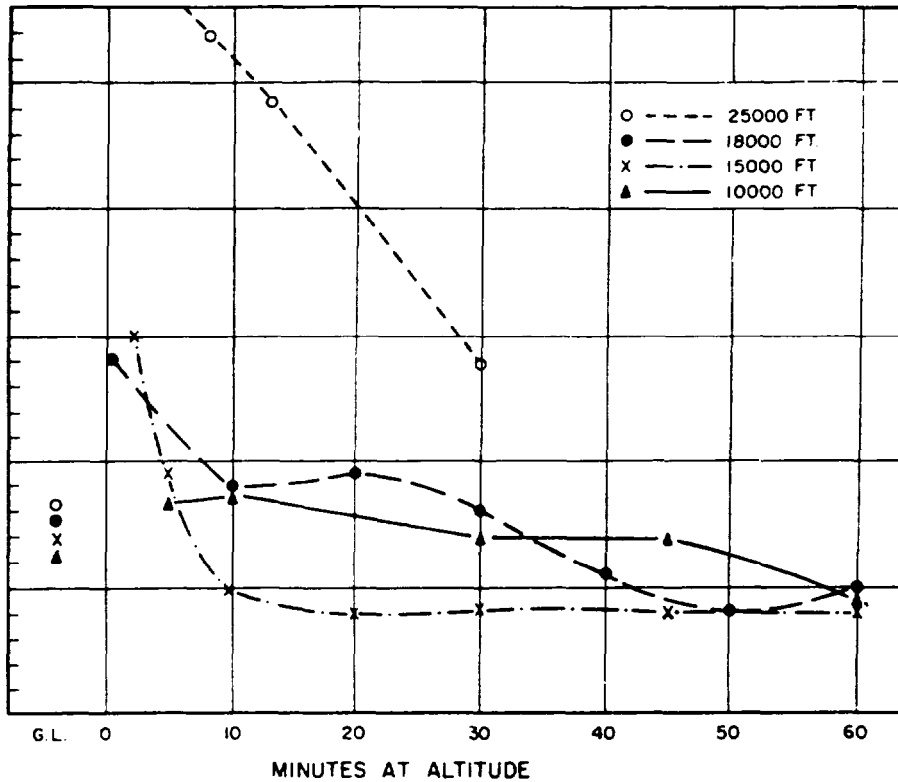

Figure 1-7. The respiratory exchange ratio in the course of exposures to 10,000, 15,000, 18,000 and 25,000 feet, indicating the duration of the “unsteady state” (Boothby, Lovelace, Benson, & Strehler, 1954).

Having arrived at the allowable lower limit of $PO_2(\text{alv})$, various equivalent altitudes yielding the same $PO_2(\text{alv})$ can be compared. In breathing oxygen not under pressure, Table 1-10 shows a $PO_2(\text{alv})$ of 61 mm Hg at 39,500 feet, which is, therefore, the upper limit for flying without positive pressure breathing. Similarly, other limiting altitudes are noted.

A question may arise as to why 10,000 feet while breathing air, or a $PO_2(\text{alv})$ of about 60 mm Hg, was selected as the upper limit for flight without oxygen. Reference to Table 1-6 shows that 10,000 feet is the upper limit for the indifferent stage of hypoxia. Even more important, reference to the oxyhemoglobin saturation curve shows that ascent to 10,000 feet causes a decrease of only about seven percent in the oxyhemoglobin saturation, since at 10,000 feet the hemoglobin is still 90 percent saturated. However, rather small increases in altitude thereafter cause a rather marked

Physiology of Flight

Table 1-10

Limiting Altitude for Respiratory Functioning

Altitude	Atmospheric pressure (mm Hg)	Alveolar P_{O_2} (mm Hg)		Reaction	Protection
		Breathing air	Breathing 100 percent O_2		
63,000	47	In theory, body water vaporizes at this altitude or above.
50,000	87	Effective limit for short-time mask pressure breathing.	Full pressure suit mandatory for any higher altitude.
43,000	122	44	Effective limit of pressure breathing for sustained flight.	Full pressure suit mandatory of extended exposure above this altitude.
39,500	144	61	$O_{2(alv)}$ drops to level equal to 10,000 feet even with 100 percent O_2 .	Limit for nonpressure breathing masks.
35,000	179	90	Maximum altitude maintained by full pressure suit.
33,700	191	103	$O_{2(alv)}$ with 100 percent O_2 equal to that at sea level breathing air.	Regulators begin positive pressure O_2 delivery.
27,000	259	27	180	Diluter demand O_2 system goes to 100 percent O_2 .
18,500	372	37	300	Usual lower limit for possible occurrence of dysbarism.
10,000	523	61	443	Lower limit for compensatory stage of hypoxia.	O_2 used on all flights above 10,000 feet.
5,000	632	79	550	Lower limit for hypoxic effects on special senses.	O_2 is recommended above 5,000 feet on night flights.
Sea level	760	103	673		

steepening of the slope of the curve. Certainly a 2,000 to 3,000 foot difference would not matter much, but anything over that becomes unacceptable; hence, the NATOPS limitation to 13,000 feet for not over three hours for certain types of flights.

The theoretical considerations just discussed set limits which are useful in making predictions and calculations. In military operations, however, many variable factors must be taken into account. If the oxygen mask suspension is not tightly adjusted, or if the mask is improperly fitted to the aviator, a lower $PO_2(\text{alv})$ will be measured in the individual using that equipment than would be predicted, due to dilution of the inspired oxygen with cabin air. There are other factors which could also account for considerable variation in the absolute PO_2 delivered to the trachea at the same altitude using the same equipment at the same settings, but on different days or even different flights.

Individual variations in diffusion rates for the alveolar membrane, or in the amount of circulating hemoglobin, or in several other physiological variables, could also result in a lower arterial PO_2 than expected from the same $PO_2(\text{alv})$. The significance is that the range of variability both in supply and among individuals must be compensated for by the supply of oxygen. The mechanical means will be discussed later, but one example of the built-in safety factors in oxygen equipment is given here.

From calculations of $PO_2(\text{alv})$ as noted in Table 1-10, 33,700 feet is the altitude at which an individual breathing 100 percent oxygen has the same $PO_2(\text{alv})$ as an individual breathing air at sea level. If no safety factor were included, the aneroid of the diluter-demand oxygen regulator would be set so that the regulator would deliver 100 percent oxygen at that altitude. Oxygen would be wasted if the regulator were set to deliver 100 percent at any lower altitude. (The reason for attempting to conserve oxygen is that oxygen quantity, like fuel quantity, is a limiting factor on aircraft range.)

In actuality depending upon the diluter-demand regulator utilized, 100 percent oxygen is delivered between 20,000 to 32,000 feet rather than at 33,700 feet. Such safety factors are built into almost all Navy life support equipment, not only to anticipate the wide variation in human response, but also to guard against some slight misuse or maladjustment of the equipment.

The theoretical upper limit of altitude which can be endured by the unprotected body is the point at which the ambient pressure is equal to or lower than the vapor pressure of water at a body temperature 98.6° F. Above that limit, much of the water in the body would vaporize. Theoretically, this would occur at 63,000 feet with a barometric pressure of 47 mm Hg. Actually this "critical" altitude must be modified upward since the water in the body is contained in the pressure vessels of cells, intravascular spaces, etc. The only situation in which the body water might vaporize is one in which an aviator who is flying at or above this altitude limit, with the cabin pressurized to a much lower altitude, experiences a rapid decompression to ambient pressure.

Physiology of Flight

This upper limit has been tested experimentally and appears to be rather on the low side of the actual figure.

In experiments on the unprotected human hand (Figure 1-8), it was found that a pressure below that equal to water vapor pressure at skin temperature was required to cause vaporization of body water. The discrepancy may have been due to the forces exerted by connective tissues within the hand and the elastic nature of the skin covering.

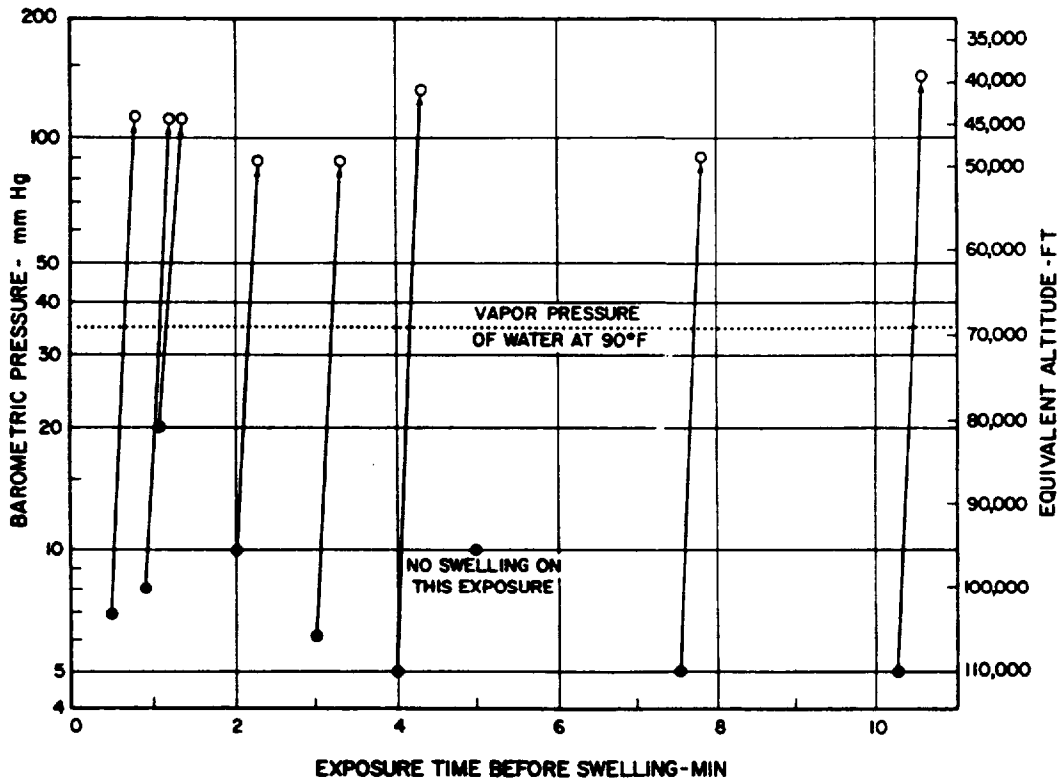

Figure 1-8. Water vapor in tissue at extreme altitudes (Billings & Roth, 1964).

Appearance of water vapor occurred suddenly and manifested itself by marked swelling of the hand after a variable time at altitude. After appearance of swelling, the pressure in the altitude chamber was quickly raised; the hand was examined periodically. The upper point (o) represents the first point at which swelling was no longer visible to the eye.

If chamber pressure was again lowered slightly, swelling again appeared, indicating the continued presence of bubble nuclei in the hand tissues. This suggests that once water vapor bubbles

appear, oxygen and carbon dioxide diffuse into the bubbles, which become transformed into bubbles of gas saturated with water vapor.

For the Navy and Marine Corps aviator, the NATOPS Manual, OPNAVINST 3710.7 series limits flights in pressurized aircraft flown by aviators not utilizing full pressure suits to 50,000 feet.

Hyperventilation

Among the perils that test the prudence and stamina of a pilot and is closely associated with hypoxia, is a breathing disorder called hyperventilation. Although unrelated in cause, the symptoms of hyperventilation and hypoxia are similar and often result in confusion and inappropriate treatment.

Definition of Hyperventilation

Hyperventilation is defined as excessive rate or depth of breathing. The increase in ventilation leads to a lowering of alveolar carbon dioxide tension, a condition referred to as hypocapnia. In addition, the acid-base balance of the blood becomes more alkaline, a condition referred to as a respiratory alkalosis.

Causes of Hyperventilation

Among the causes that can lead to hyperventilation are hypoxia, pressure breathing, psychological stress, and pharamocological stimuli.

Hypoxia With the onset of hypoxia above 10,000 feet, oxygen tension in the lungs and arterial blood is reduced. This reduced arterial PO₂ reflexively stimulates the respiratory center via the aortic and carotid peripheral chemoreceptors, causing increased breathing.

Pressure Breathing. There is a tendency to over breathe during positive pressure breathing. Positive pressure which is used to prevent hypoxia, creates a reversal of the normal respiratory cycle of inhalation and exhalation. Under positive pressure breathing, the aviator is not actively involved in inhalation as in the normal respiratory cycle. Instead of the aviator inhaling oxygen into the lungs, oxygen, under pressure, is forced into the lungs. During exhalation under positive pressure breathing, the aviator must breathe out against pressure. The force that the individual must exert in exhaling results in an increased rate and depth of breathing.

Psychological Stress. The human psyche can also override the normal respiratory controls. Fear, anxiety, stress or tension, resulting from emotion or physical discomfort, will sometimes cause an individual to override the normal reflex control of breathing. This cause is most frequently encountered during initial low pressure chamber flights and early inflight training, and is probably the most common cause in all types of flying.

Pharmacological Stimuli. Pharmacological stimuli to hyperventilation only become important when aircrew who are taking drugs continue to fly. The major groups of drugs that cause hyperventilation are salicylates, female sex hormones, catecholamines and analeptics.

Effects of Hyperventilation

The two primary results of hyperventilation are hypocapnia and alkalosis. The hypocapnia and alkalosis have an effect on the respiratory, cardiovascular and central nervous systems.

Respiratory System. The effect of hyperventilation on the respiratory system is primarily on the blood buffer system. Seventy percent of the carbon dioxide present in the blood is carried as a bicarbonate ion. The overall reaction for bicarbonate formation occurs as follows:



The major influence determining the direction in which the above reaction proceeds is the concentration, or partial pressure of carbon dioxide. When the carbon dioxide levels in the blood increase, the reaction proceeds to the right, toward the formation of greater hydrogen and bicarbonate ions. When the carbon dioxide level decreases, the reaction reverses toward the formation of carbon dioxide and water. When an individual hyperventilates, the excessive elimination of carbon dioxide causes a reduction in hydrogen ion concentration that is too rapid for the blood buffer system to replace. The pH is elevated and a respiratory alkalosis ensues.

Cardiovascular System. It is generally agreed that hyperventilation causes tachycardia, increased cardiac output and reduced systemic vascular resistance and mean arterial blood pressure. Hyperventilation also causes vasoconstriction of cerebral blood vessels, vasodilation of systemic blood vessels and reduced coronary blood flow resulting in lowered myocardial oxygen tension. The combined effects of systemic vasodilation and cerebral vasoconstriction cause a restriction in blood flow to the brain. The primary cardiovascular effect is on the oxyhemoglobin dissociation curve. Hyperventilation shifts the oxyhemoglobin curve upward and to the left, called the Bohr effect. This shift increases the capacity of blood to onload oxygen on the lung level but restricts

offloading at the tissue level. The combined effect of restricted blood flow and increased oxygen binding results in stagnant hypoxia at the brain which leads to unconsciousness.

Central Nervous System. Hyperventilation and the resulting elevated pH cause an increased sensitivity and irritability of neuromuscular tissue. This increase is manifested by superficial tingling and numbness of the extremities and mouth, and muscular spasm and tetany. The tingling usually precedes muscular spasm and tetany. The hands and feet may exhibit carpopedal spasm, a fixation of the hand wherein the fingers are flexed toward the wrist or a marked plantar flexion of the ankle. Muscle spasm usually occurs when the arterial carbon dioxide tension has been reduced to 15 to 20 mm Hg. In more severe hypocapnia, with an arterial carbon dioxide tension less than 15 mm Hg, the whole body becomes stiff (tetany) due to contraction of skeletal muscle. Figure 1-9 summarizes the effects of hyperventilation.

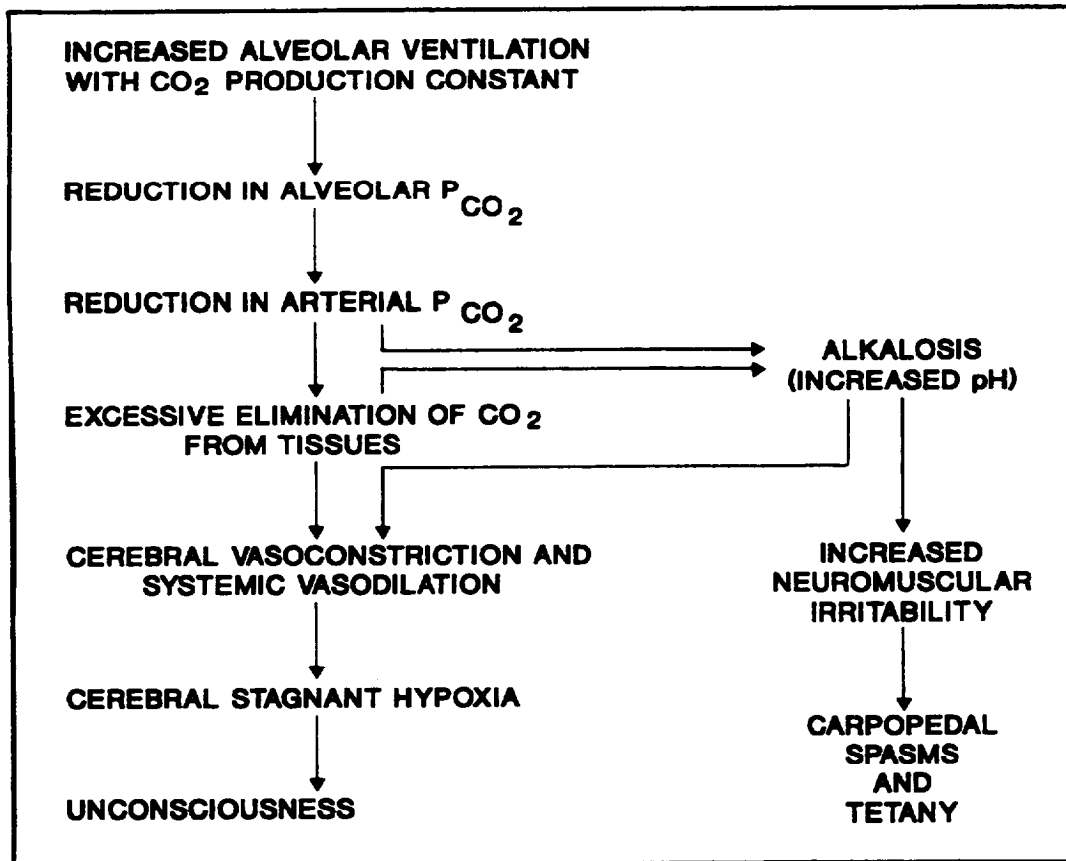

Figure 1-9. Effects of hyperventilation.

Signs and Symptoms of Hyperventilation

The signs and symptoms of hyperventilation are not easily differentiated from and can easily be confused with those of hypoxic hypoxia.

Objective Signs. The objective signs of hyperventilation most often observed in another individual are:

1. Increase rate and depth of breathing.
2. Muscle twitching and tightness.
3. Paleness.
4. Cold clammy skin.
5. Muscle spasms.
6. Rigidity.
7. Unconsciousness.

Subjective Symptoms. The subjective symptoms, those perceived by the individual include:

1. Dizziness.
2. Light headedness.
3. Tingling.
4. Numbness.
5. Muscular incoordination.
6. Visual disturbance.

Similarity to Hypoxia

While the etiology of hypoxia and hyperventilation are different, the symptoms are quite similar making it difficult to differentiate between the two. There are, however, a few distinguishing differences in these two syndromes. In hyperventilation, the onset is gradual, with the presence of pale, cold, clammy skin and the development of muscle spasm and tetany. In hypoxia, the onset of symptoms is usually rapid (altitude-dependent), with the development of flaccid muscles and cyanosis.

Treatment of Hyperventilation

Since hypoxia and hyperventilation are so similar and both can quickly incapacitate, the recommended treatment is aimed at correcting both problems simultaneously. There are five steps for treatment:

U.S. Naval Flight Surgeon's Manual

1. Go to 100 percent oxygen if not already on it.
2. Check oxygen equipment to ensure proper functioning.
3. Control breathing - reduce the rate and depth.
4. Descend below 10,000 feet where hypoxia is an unlikely problem.
5. Communicate problem.

Positive Pressure Breathing

The requirement for positive pressure breathing in naval aviation is predicated on the degree of hypoxia acceptable for safe mission performance. Safe mission performance is based on a minimal alveolar partial pressure of oxygen of 60 mm Hg. This alveolar partial pressure of oxygen is reached at approximately 39,000 feet breathing 100 percent oxygen. To maintain the minimum alveolar partial pressure of oxygen above 39,000 feet, positive pressure must be applied to the breathing oxygen.

Positive pressure breathing in operational aircraft is an indication of an emergency condition which occurs when cabin pressurization is lost at or above 35,000 feet. In the event of cabin pressurization failure at altitudes above 35,000 feet, pressure breathing is employed to maintain consciousness and physical function so that a rapid controlled descent to lower altitudes may be accomplished. As long as the cabin pressurization system is functioning normally, the aviator should not experience positive pressure breathing.

Kinds of Positive Pressure Breathing

Simply stated, positive pressure breathing is the delivery of a gas to the respiratory tract at a pressure greater than ambient. There are two kinds of positive pressure breathing: intermittent positive pressure breathing and continuous positive pressure breathing.

Intermittent Positive Pressure Breathing (IPPB). IPPB provides pressure behind the breathing gas on inspiration, but during expiration the pressure is removed. The mean mask pressure is approximately one third of the highest pressure applied during the inspiratory phase.

Continuous Positive Pressure Breathing (CPPB). CPPB provides pressure behind the breathing gas throughout the respiratory cycle. Assuming a good mask fit without leakage, the mean mask pressure is nearly equivalent to the positive pressure delivered by the regulator, and the alveolar gas pressure is correspondingly raised. The highest mean mask pressure of oxygen offers the best physiological protection against hypoxic hypoxia. Since this is obtained with CPPB breathing, this system is utilized in Naval aviation.

Respiratory Effects of Positive Pressure Breathing

Distention of Lungs and Chest. The stress on the walls of the lungs normally depends upon their degree of inflation, the support of the walls of the thoracic cavity and the maximum pressure which can be exerted and held in the lungs by active contraction of the expiratory muscles. Pressure breathing tends to distend the chest and lungs. In a relaxed individual, when no muscular effort is made, the lungs are fully distended by a pressure of 20 mm Hg. If the lungs are unsupported by the chest wall (i.e., open thorax) they will rupture when the intrapulmonary pressures exceeds 40-50 mm Hg. When, however, the chest wall is intact, intrapulmonary pressures up to 80 to 100 mm Hg can be tolerated without damage. At intrapulmonary pressures between 80 to 100 mm Hg, parenchymal lung damage secondary to overexpansion may occur if the expiratory muscles are relaxed. While overdistention of the lung is possible, lung rupture is not probable. The greatest pressure output of current naval regulators is 30 mm Hg, well below the threshold of lung damage even in an open chest.

Pulmonary Ventilation. In most subjects, pressure breathing causes an increase in minute ventilation. The increase is due to both an increase in tidal volume and frequency of breathing. There is a wide variation in pulmonary ventilation response which depends to a great extent on individual experience with positive pressure breathing. Pressure breathing at 30 mm Hg causes a mean increase in the respiratory minute volume of 50 percent over the resting value. Some individuals double their minute volume at 30 mm Hg while others hardly respond.

Intrapleural Pressure. The increase in intrapleural pressure which occurs during positive pressure is important since it determines the magnitude of insult on the cardiovascular system. The increase in the intrapleural pressure is a function of the applied positive pressure and the degree of lung distention. If there is no increase in lung volume, the intrapleural pressure will equal the applied positive pressure. If lung distension occurs, the intrapleural pressure will be less than the breathing pressure by an amount equal to the pressure produced by the elastic recoil of the distended lung. The elastic recoil pressure of the lung is approximate 4 mm Hg per liter of lung distension. If for example, the lung volume is increased by 4 liters, the rise in intrapleural pressure will be approximately 16 mm Hg less than the applied positive pressure.

Breathing Effort. In continuous positive pressure breathing the normal breathing cycle of an active inspiration and passive expiration is reversed to a passive inspiration and an active expiration. This reversal in cycle makes the act of breathing more difficult and increases the work of breathing. Experienced subjects can breathe for short periods at pressures up to about 50 mm Hg, whereas those unaccustomed to this maneuver cannot tolerate breathing pressures greater than 30 mm Hg.

Circulatory Effects of Positive Pressure Breathing. The circulatory disturbances produced by positive pressure breathing depend upon the magnitude and duration of the applied pressure. Positive pressure breathing increases intrapulmonary pressure which in turn results in an increase in intrapleural pressure. It is the rise in intrapleural pressure rather than the increase in intrapulmonary pressure that determines the stress applied to the circulatory system. The heart and intrathoracic vessels are normally subjected to intrapleural pressure. The diastolic pressure within these vessels will be raised at the beginning of positive pressure by an amount equal to the rise in intrapleural pressure.

Venous Pooling. At the start of pressure breathing the increase in intrapleural pressure is transmitted to the right atrium and large intrathoracic veins. Since the pressure in the extrathoracic vessels is normally low, this increase in central venous pressure seriously impedes the flow of blood from the systemic veins to the heart and venous outflow from the limbs completely ceases.

Although venous outflow from the limbs ceases with the onset of positive pressure breathing, arterial inflow continues. Blood as a result, collects in and distends the venules and veins of the peripheral vascular bed until peripheral pressure exceeds right atrial pressure. At that point venous return is restored from the limbs thereby increasing the systemic venous return to the heart. This initial phase of reduction of venous return to the heart lasts about 10 to 20 seconds.

Reduction in Circulating Blood Volume. Effective blood volume, that volume of blood available for circulation, is reduced during positive pressure breathing by two factors:

1. Initial pooling of blood (described above).
2. Passage of fluid from the capillaries into the tissue.

The rate at which fluid leaves the capillaries depend on the rise in capillary pressure which is closely related to the increase in venous pressure. Pressure breathing for 10 minutes at 30 mm Hg has resulted in a loss of 250 ml of fluid while pressure breathing for 5 minutes at 100 mm Hg has resulted in a loss of 500 ml of fluid into the tissue. The total reduction in effective blood volume which occurs during pressure breathing results from the combined effects of initial pooling of blood and the passage of fluid from the circulation into the tissue. During pressure breathing at 30 mm Hg for 10 minutes total reduction is of the order of 450 ml. Pressure breathing at 100 mm Hg for 5 minutes reduces the effective blood volume in the order of 950 ml.

Reduced Cardiac Output. The reduction in effective blood volume due to pooling of blood and increase in extravascular fluid results in a reduced cardiac output. Pressure breathing at 30 mm

Physiology of Flight

Hg without trunk counterpressure reduces cardiac output some 30 percent. If counterpressure is applied, 30 mm Hg pressure breathing reduces cardiac output by 15 to 20 percent.

Advantages of a Positive Pressure Breathing

1. The equipment is inexpensive, reliable, instantly available, and requires comparatively little maintenance.
2. With a small amount of training, a definite increase in service ceiling can be obtained.

Disadvantages of Positive Pressure Breathing.

1. The service ceiling increase is small (about 5,000 feet) and limited.
2. The limitations are those caused by possible injury to the aviator.
3. Pressure breathing is opposite to the normal breathing pattern in that inhalation is passive and exhalation active, thus requiring training and familiarization.
4. The process of pressure breathing is fatiguing.
5. Communications are much more difficult during pressure breathing.
6. Hyperventilation with resulting respiratory hypocapnia is very common even in moderately experienced aviators.

Effectiveness of Positive Pressure

In view of the major side effects which include decreased venous return, decrease cardiac output, increase arterial blood pressure, distention of extra thoracic veins, tachycardia, possible rupture of alveoli and possible syncope, 15 mm Hg represents a practical maximum for sustained positive pressure breathing. Since roughly 3 mm Hg pressure increase is required for each 1000 feet gain in altitude above 40,000 feet, the 15 mm Hg practical maximum raises the physiological altitude ceiling only from 40,000 to 45,000 feet. This is not really a significant rise in terms of altitude capabilities of current and future operational aircraft. The emergency ceiling of pressure breathing is 50,000 feet. At this altitude the pressure delivered is approximately 33 mm Hg. In sudden decompression to 50,000 feet, positive pressure breathing can be utilized for a brief period of time to sustain useful consciousness and permit a rapid descent to a lower altitude. The minimum and maximum pressures delivered at various altitudes are summarized in Table 1-11.

Table 1-11

Positive Pressure Loading at 10 LPM Ambient Flow

<i>Positive pressure (inches of water)</i>		<i>Altitude in feet</i>
<i>Minimum</i>	<i>Maximum</i>	
	3.5	35,000
	5.7	37,000
	8.0	39,000
2.0	9.4	40,200
4.0	10.2	41,000
6.0	10.8	41,500
8.0	12.0	42,500
10.0	12.5	43,000
	18.0	(1)

¹ 50,000 feet and above. 1 inch water = 1.87mm Hg.
(NAVAER 00-80 T-52).

Bailout Oxygen Supply

All tactical jet aircraft have an emergency oxygen supply in a high pressure oxygen cylinder. The cylinder is contained in the rigid seat survival kit of the ejection seat. For each type of aircraft seat the cylinder capacity varies. In the F-14 the approximate oxygen supply time is 20 minutes while in the F/A-18 it is 10 minutes. The emergency oxygen supply is automatically actuated during the ejection sequence.

Time to Ground. An emergency oxygen supply is necessary for use during the time required for descent by free fall from high altitudes, or the even longer times when the parachute is opened prematurely. Table 1-12 shows that from 40,000 feet, time of useful consciousness is 18 seconds, while time to free fall to 14,000 feet is 90 seconds, and time to descent to 14,000 feet is 900 seconds (or 15 minutes), with the 28 to 30 foot parachute open. Obviously, some provision must be made to keep the pilot alive during such a parachute descent. Barometrically actuated parachute openers allow an aviator to free fall in the unconscious condition and survive, but accidental parachute deployment at high altitude would cause certain death or at least unconsciousness from hypoxia if emergency oxygen could not be supplied. Note that in Figure 1-10 the time to free fall from 28,000 feet to 14,000 feet is the same as the useful consciousness time at 28,000 feet. For rough approximations, therefore, 28,000 feet is the highest altitude from which

Physiology of Flight

free fall can be accomplished while breathing ambient air and retaining consciousness. Actually, the time of useful consciousness increases as the subject falls, but this may be considered a safety factor.

Table 1-12

Period of Useful Consciousness in High Altitude Bailout

Bailout altitude (feet)	(Time in seconds)		
	Useful consciousness	Free fall to 14,000 (feet)	28- to 30-foot chute to 14,000 feet
75,000.....	12	150	1,680 (28 minutes).
55,000.....	12	120	1,200 (20 minutes).
40,000.....	18	90	About 900 (15 minutes).
30,000.....	75	60	600 (10 minutes).

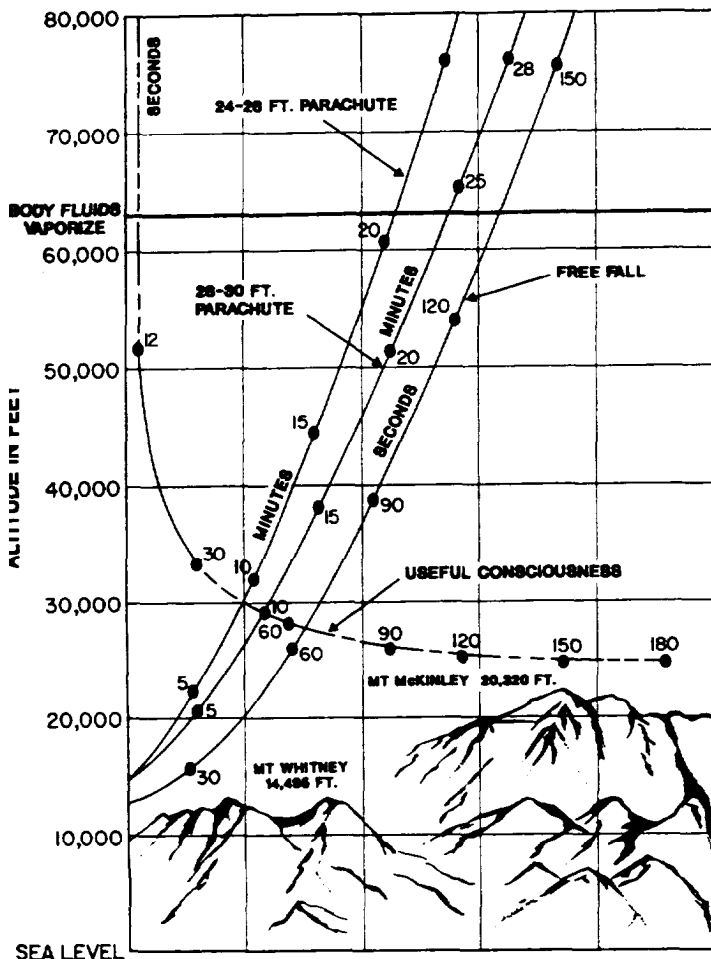

Figure 1-10. Descent to safe breathing altitude (Carlyle, 1963).

Cabin Pressurization

The physiological zone which extends from sea level to 10,000 feet, encompasses the pressure area to which man is well adapted. Although middle ear or sinus problems may be experienced during descent or ascent in this zone, most physiological problems occur outside this zone if suitable protective equipment is not utilized. In general, the most effective way of preventing physiological problems from occurring is to provide cabin pressurization so that occupants are never exposed to pressure outside the physiological zone. In these instances when ascent above the physiological zone is required, protective oxygen equipment and pressure garments must be provided.

Methods of Maintaining Cabin Pressure

The higher the differential pressure required between cabin pressure and ambient pressure, the greater the capacity of the pressurization system, and the stronger and heavier the fuselage construction; There are two methods of maintaining cabin pressure above ambient.

1. *Sealed Cabins.* At very high altitudes, a point is reached where the ambient air becomes so thin that it is impossible for the compressor to scoop up enough air for compression. When this occurs the compressor stalls, and the pressurization fails. At approximately 80,000 feet ambient altitude, cabin pressurization cannot be accomplished via the conventional method because of the “rarified” atmosphere. At this point, sealed cabins must be used to maintain an adequate environment. Pressurized gas is carried within the vehicle and the used gas recycled. Since this is a closed system, the environmental gas must be continually purified and recirculated to conserve the supply (Figure 1-11). This system is utilized at extremely high altitudes and in the vacuum of space.

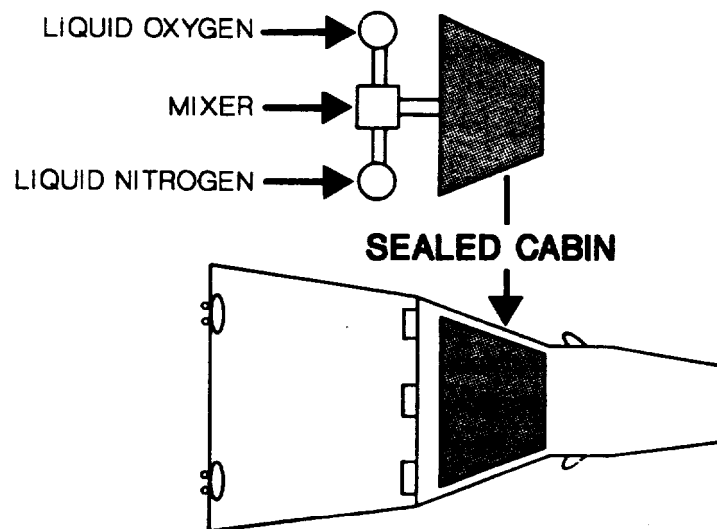
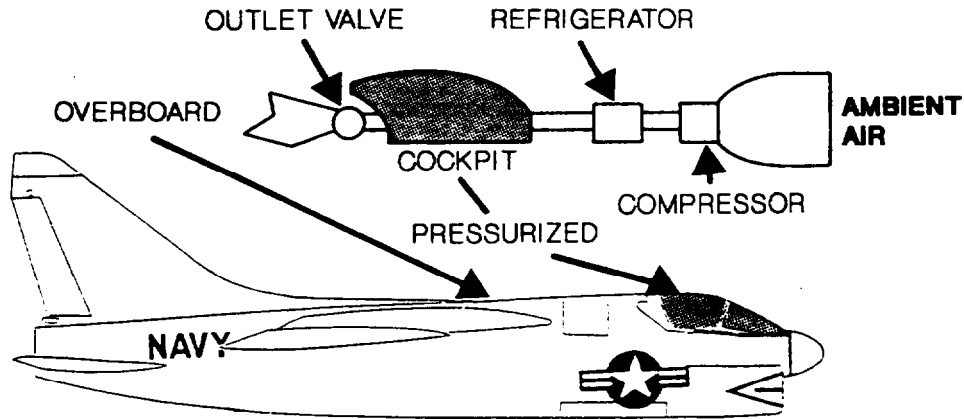

Figure 1-11. Schematic of sealed cabin.

2. *Conventional Method.* The conventional method for increasing the pressure in aircraft cabins is to use ambient air as the source of gas, forcing it into the cabin by means of a

compressor. Cabin pressures and ventilation can be controlled by varying the amount of air forced into the cabin and the amount allowed to escape through adjustable outflow valves (Figure 1-12).



Figures 1-12. Schematic of pressurized cabin.

The conventional method for cabin pressurization utilizes two types of pressurization schedules. These are the isobaric and the isobaric- differential.

- a. *Isobaric System.* Isobaric Control refers to the condition where the cabin altitude is maintained at a constant altitude or pressure as the ambient pressure decreases (Figure 1-13). This type of pressurization system is found in most cargo and passenger carrying aircraft. Military air transport aircraft (e.g., T-39, C-131, C-9, T-44, P-3) typically maintain a cabin pressure approximately equivalent to 8000 feet of altitude through the ceiling of the aircraft.
- b. *Isobaric-Differential System.* Pressurization of aircraft cabins represents an excellent example of engineering tradeoff. A high differential requires an aircraft structure which is physically stronger and therefore heavier than that required for a lower differential. The increased weight in turn, decreases the payload of the aircraft. Pressurization requires an expenditure of energy; therefore, the larger the differential the greater the power required to provide the desired pressure and less power available for aircraft maneuverability. Also, the higher

Physiology of Flight

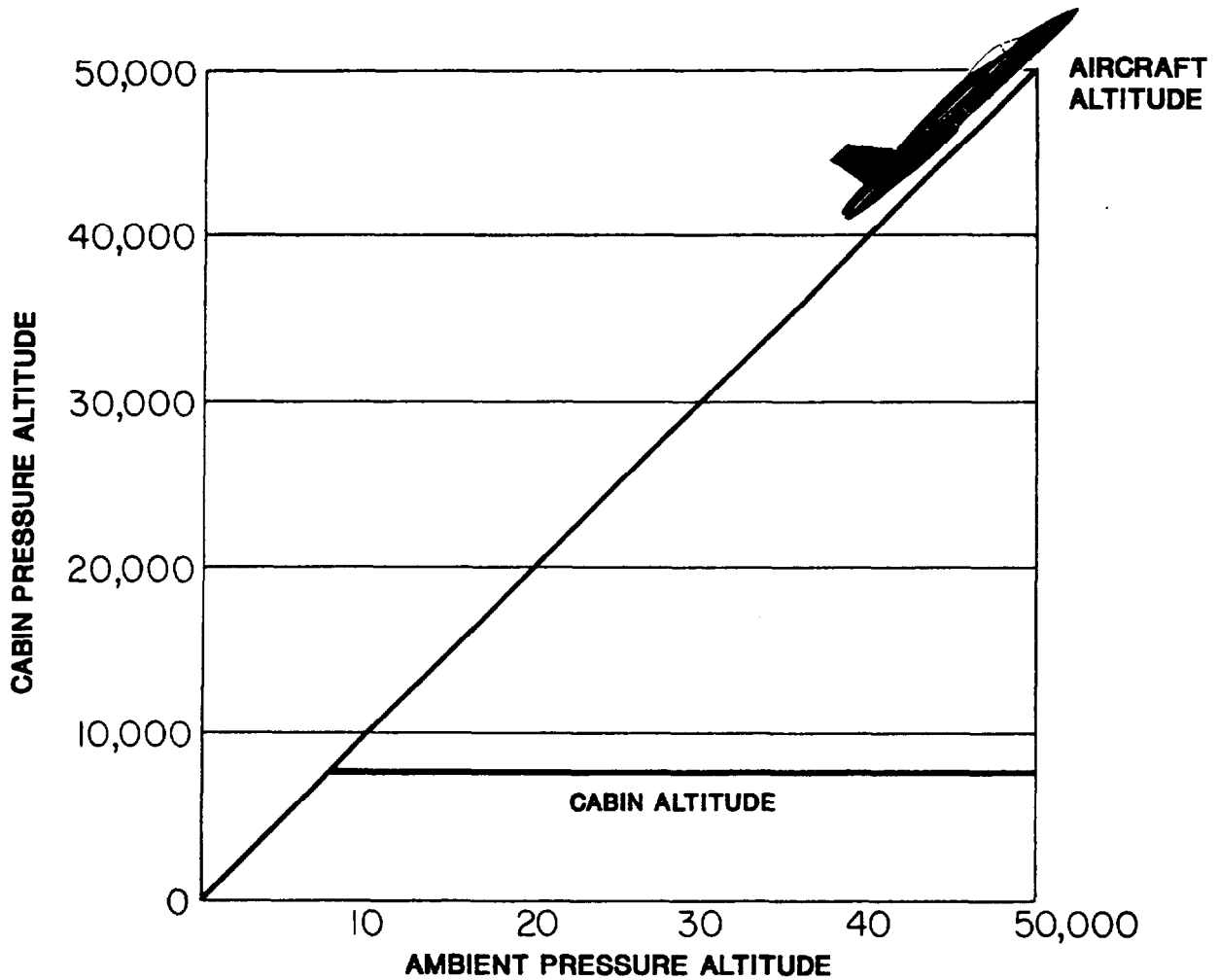

Figure 1-13. Isobaric pressure schedule.

the pressure differential, the greater the possibility of a rapid decompression. Tactical jet aircraft are equipped with an isobaric-differential pressurization system. This pressurization system senses both cabin and ambient pressure and maintains the cabin pressure on the basis of a fixed pressure differential of 5 psi. Figure 1-14 shows a typical isobaric-differential pressurization schedule found in Navy tactical jet aircraft. As the aircraft climbs, the aircraft is unpressurized to an altitude of 8,000 feet. From 8,000 feet to approximately 23,000 feet, cabin pressure remains at 8,000 feet (isobaric range). From 23,000 feet up to the ceiling

of the aircraft, the cabin pressure is maintained at a pressure differential of 5 psi. For example, if an aircraft is flying at an indicated ambient altitude of 40,000 feet where the pressure is 2.72 psi outside the aircraft, and the pressurization system is in normal operation, the effective cabin altitude would be 7.72 psi or approximately 16,500 feet.

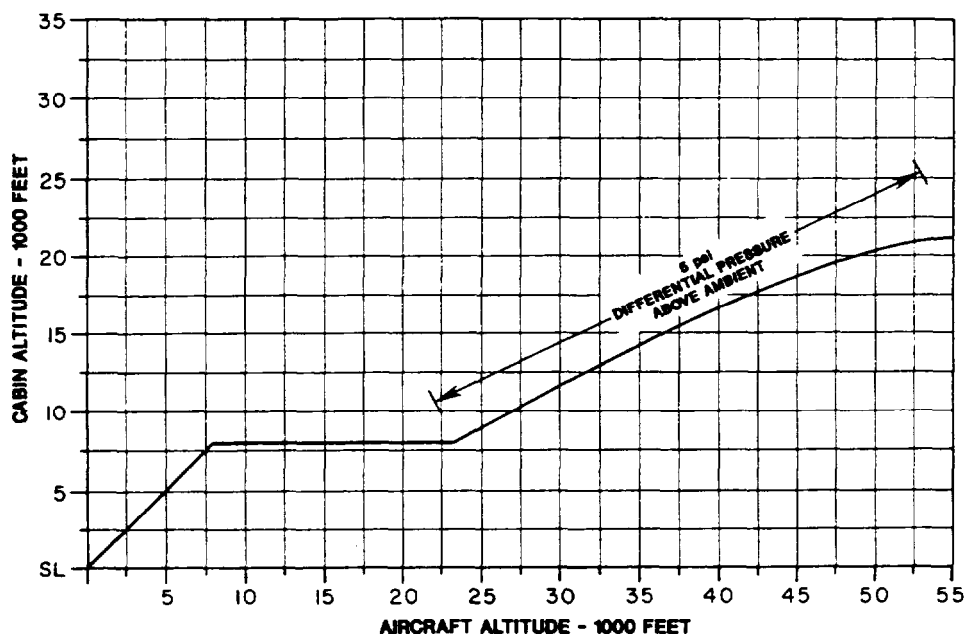

Figure 1-14. F-14A aircraft cabin pressure schedule.

Advantages of Pressurized Cabins

Reducing the probability of hypoxia and decompression sickness are perhaps the two most important advantages of the pressurized cabin. Other advantages of cabin pressurization include:

1. Reduces the need for supplemental oxygen except in tactical jet aircraft where it is required from takeoff to landing.
2. Gastrointestinal trapped gas pains are reduced.
3. Cabin temperature, humidity and ventilation can be controlled within desired comfort levels.

Physiology of Flight

4. In large aircraft, the crew and passengers can move about freely in a comfortable environment unencumbered by oxygen masks or other life support equipment.
5. Prolonged passenger flights, air evacuation, and troop movements can be accomplished with a minimum of fatigue and discomfort.
6. Protection against pain in the middle ear and sinuses can be provided by permitting the pressure in the cabin to rise slowly in a controlled manner during descent from high altitude to ground level.

Disadvantages of Pressurized Cabins

The penalties for the above mentioned advantages are the following disadvantages:

1. Increased structural weight and strength of the pressurized area to maintain structural integrity.
2. Additional equipment and power requirements to support the pressurization, ventilation and air conditioning systems.
3. Maximum performance and payload capacity of the aircraft is reduced because of added weight.
4. Additional maintenance and upkeep is needed.
5. Possible contamination of the cabin air from smoke, fumes, carbon monoxide, carbon dioxide and odors.
6. Should a rapid decompression occur, the occupants of the aircraft are exposed to the dangers of hypoxia, decompression sickness, gastrointestinal gas expansion and hypothermia. In addition, the cyclonic winds create the possibility of personnel being lost through the opening.

Rapid Decompression

Aircrew members are faced with many hazardous factors when performing duties involving flying. Decompression at altitude is one of those factors that can cause significant physiological problems. Decompressions are categorized as either “slow” or “rapid”. A slow decompression can

occur when a leak develops in a pressure seal. This type of decompression is dangerous because of the possible insidious effect of hypoxia. Rapid decompressions are considered more dangerous. They can occur as a result of a perforation of the cockpit or cabin wall or unintentional loss of the canopy or hatch.

Factors Controlling the Rate and Time of Decompression

The principal factors that govern the total time of decompression include the cabin volume, size of the opening, the pressure ratio, and the pressure differential.

Volume of the Pressurized Cabin. The decompression time within a larger cabin area will be considerably slower than that of a cabin with less area.

Size of the Opening. The proportionality of cabin volume and cross sectional area of the opening dictates the decompression rate and time.

Pressure Ratio. Variables involved in determining the time of decompression are the pressure within the cabin and the outside ambient pressure. If the pressure ratio is increased, then it can be presumed that the time for the air to escape will also be increased. The end result being a greater decompression time.

Pressure Differential. The difference between the internal and external cabin pressures will influence both the rate and severity of the decompression. The larger the pressure differential, the more severe the rapid decompression.

Physical Characteristics of Rapid Decompression

There are a few physical and observable characteristics that help in the recognition of a rapid decompression. All of the following may indicate a loss of cabin pressurization.

Noise. When two different air masses contact, there is a noise that ranges from a "SWISH" to a loud explosive sound. It is because of this explosive noise that some people use the term explosive decompression to describe a rapid decompression.

Fogging. Air at any temperature and pressure has the capability of holding just so much water vapor. Sudden changes in temperature or pressure, or both, change the amount of water vapor the air can hold. In a rapid decompression, temperature and pressure are reduced. This reduction in temperature and pressure reduces the holding capacity of air for water vapor. The water vapor that cannot be held by the air appears as fog.

Physiology of Flight

Temperature. Ambient temperatures get colder with increasing altitude. If a decompression occurs, cabin temperature will equalize with outside ambient temperature, resulting in a significant decrease in cabin temperature. Chilling or frostbite are possibilities depending upon the altitude.

Flying Debris. Upon decompression, the rapid rush of air from a pressurized cabin causes the velocity of airflow through the cabin to increase rapidly as the air approaches the hole. The rush of air has such force that items not secured will be extracted through the opening. There has been an instance of an inadequately restrained individual in the immediate vicinity of an opening being sucked from the aircraft.

Physiological Effects of Rapid Decompression

The occupants' primary concerns are hypoxia, gas expansion, decompression sickness and hypothermia.

Lungs. The lungs are potentially the most vulnerable part of the body during a rapid decompression. Whenever a rapid decompression is faster than the inherent capability of the lungs to decompress, a transient positive pressure will temporarily build up in the lungs. If the escape of air from the lungs is blocked or seriously impeded during a sudden drop *in* cabin pressure, intrapulmonary pressure can build up high enough to cause tearing and rupture of the lung tissues and capillaries. If the expanding gas is free to escape from the lungs through an open airway, the risk of lung damage is nonexistent. Momentary breath-holding, such as swallowing or yawning will not cause excessively high intrapulmonary pressure and over expansion of lung tissue.

Ears and Sinuses. Decompression of a pressurized cabin is unlikely to cause symptoms in the middle ear and paranasal sinuses. It is more likely, however, that individuals will develop pain in the middle ear and paranasal sinuses during the subsequent emergency descent as they will be exposed to a large and rapid increase of cabin pressure.

Gastrointestinal Tract. One of the potential dangers during a rapid decompression is the expansion of trapped gases within the gastrointestinal tract causing abdominal distress. Abdominal distention, if it does occur, may have several important effects. The diaphragm is displaced upward by the expansion of the trapped gas in the stomach which can retard respiratory movements. Distention of the abdominal organs may also stimulate the abdominal branches of the vagus nerve, resulting in cardiovascular depression, and if severe enough, cause a reduction in blood pressure, unconsciousness and shock.

Hypoxia. Of all the physiological hazards associated with the loss of pressure, hypoxia is the

most important. The rapid reduction of ambient pressure produces a corresponding drop in the partial pressure of oxygen and reduces the alveolar oxygen tension. A twofold to threefold performance decrement occurs regardless of altitude. The reduced tolerance to hypoxia after decompression is due to (1) a reversal in the direction of oxygen flow in the lung; (2) diminished respiratory activity at the time of decompression; (3) decreased cardiac activity at the time of decompression.

Decompression Sickness. In general, decompression sickness does not occur until cabin altitudes of 18,000 feet are reached. The incidence of decompression sickness is small unless the cabin altitude reaches 25,000 to 30,000 feet. As the duration of exposure to the unpressurized environment increases, so does the incidence of decompression sickness. The incidence of decompression sickness following a rapid decompression appears to be only slightly greater than after a slow decompression to the same altitude.

Hypothermia. When cabin temperatures drop because of a decompression, it is likely that injuries such as frostbite and hypothermia will exist. Again, the extent and severity will be dependent on the altitude and the type of protective clothing worn during the decompression.

Trapped Gas

During ascent, the free gas normally present in various body cavities expands. If escape of the expanded volume is impeded, pressure builds up within the cavity and pain is experienced. Expansion of trapped gases accounts for abdominal pain, sinus pain or toothache. The effects of decrease barometric pressure on the sinuses, ears and teeth are covered in detail in Chapter 8. Only a brief discussion of the etiology and symptomatology of trapped gas will be given here.

Boyle's Law

Trapped gas problems are explained by Boyle's Law. Boyle's Law states that the volume of a gas is inversely proportional to the pressure exerted upon it. According to Boyle's Law, gases trapped in body cavities expand as altitude increases, and contract as altitude decreases.

In ascending in an unpressurized aircraft, the atmospheric pressure exerted on various body cavities will decrease. As the atmospheric pressure decreases, gases trapped in body cavities will expand, putting added pressure on the body cavities in which they are trapped. These areas include air spaces in the ears, sinuses, teeth, and gastrointestinal tract.

Ears

An in-flight ear block can occur on either ascent or descent when air pressure in the middle ear is unable to equalize with ambient air pressure. This normally occurs because the lower orifice of the eustachian tube, which operates as a one-way flutter valve, fails to function adequately. It may also happen if the eustachian tube should be swollen from a cold or ear infection. The difference in pressure will cause the eardrum to bulge outward on ascent and inward on descent. This may cause discomfort in the form of pressure or pain.

As the barometric pressure is reduced during ascent, the expanding air in the middle ear (Figure 1-15) is intermittently released through the eustachian tube into the nasal passages. As the inside pressure increases, the eardrum bulges outward until an excess pressure of approximately 12 to 15 mm Hg is reached. At this time a small bubble of air is forced out of the middle ear and the eardrum resumes its normal position. Just before the air escapes from the eustachian tube, there is a sensation of fullness in the ear. As the pressure is released, there is often a click or pop.

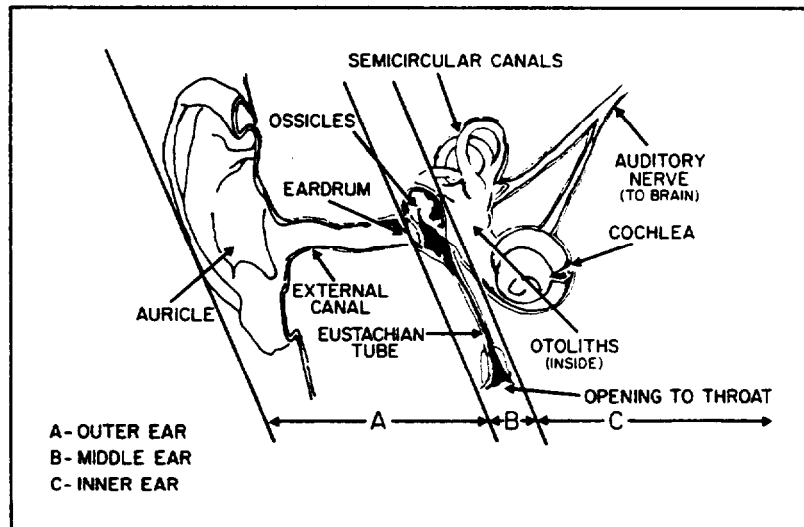

Figure 1-15. Anatomy of the ear.

An ear block is much more likely to occur on descent as the ambient pressure increases because of the valve-like action in the eustachian tube which allows gas to pass more readily from the inner ear than into it.

The symptoms of an in-flight ear block may include:

1. Pressure or pain.

2. Muffled sound.
3. Dizziness.
4. Tinnitus (ringing in the ear).

Descending rapidly from a level of 30,000 to 20,000 feet will often cause no discomfort, whereas a rapid descent from 15,000 to 5,000 feet will cause great distress. This is because the change in barometric pressure is much greater in the latter situation. For this reason, special care is necessary during rapid descents at low altitudes.

Protection Against Ear Blocks. Normally, pressure can be equalized during decent by just swallowing, yawning or tensing the muscles of the throat. These procedures cause contraction of pharyngeal muscles which open the orifices of the eustachian tube. If relief is not obtained by this method, a Valsalva Maneuver should be performed by closing the mouth, pinching the nose shut, and blowing gently, thus forcing air through the previously closed eustachian tube into the cavity of the middle ear and equalizing the pressure.

Occasionally voluntary maneuvers such as mentioned above are unsuccessful in equalizing the pressure in the middle ear. This is especially true when a pressure differential of approximately 80-90 mm Hg is developed across the middle ear. If this occurs in actual flight, relief can only be obtained by reascent to a level at which equalization of the pressure can be accomplished, followed by a slower descent. If an ear block occurs in an altitude chamber, the middle ear can be equalized by politerization.

Postflight Ear Block. On descent from high altitudes, fliers who have breathed pure oxygen during an entire flight sometimes develop an earache several hours after landing even though their ears cleared adequately during descent. Ear pain may awaken them after they have gone to sleep or may be noticed upon awaking in the morning. Gradual absorption of oxygen from the gas contained in the middle ear reduces the middle ear pressure. When the oxygen content is high, as it is after breathing oxygen, the absorption rate is accelerated. An individual who is awake relieves the slight unbalance of pressure by periodic swallowing. This opens the eustachian tubes and admits air at ambient pressure to the middle ear. During sleep, saliva flow is suppressed and swallowing is infrequent; consequently, the middle ear is not ventilated often enough to keep the pressure equalized. The result is similar to that arising from inability to ventilate the ears during descent from altitude - a sensation of blocking or fullness, sometimes pain, and possibly an accumulation of fluid in the middle ear. Usually the condition is mild and easily relieved by the Valsalva maneuver.

Physiology of Flight

Prevention of postflight ear trouble is simple. Valsalva maneuvers performed frequently during the first 1 or 2 hours after landing will lower the concentration of oxygen by flushing the middle ear with ambient air. This preventive procedure is particularly important if the flier is going to bed soon after landing.

Sinuses

The paranasal sinuses (Figure 1-16) present a condition in flight similar to that of the middle ear. The sinuses are air filled, relatively rigid, bony cavities lined with mucous membranes. They connect with the nose by means of one or several small openings.

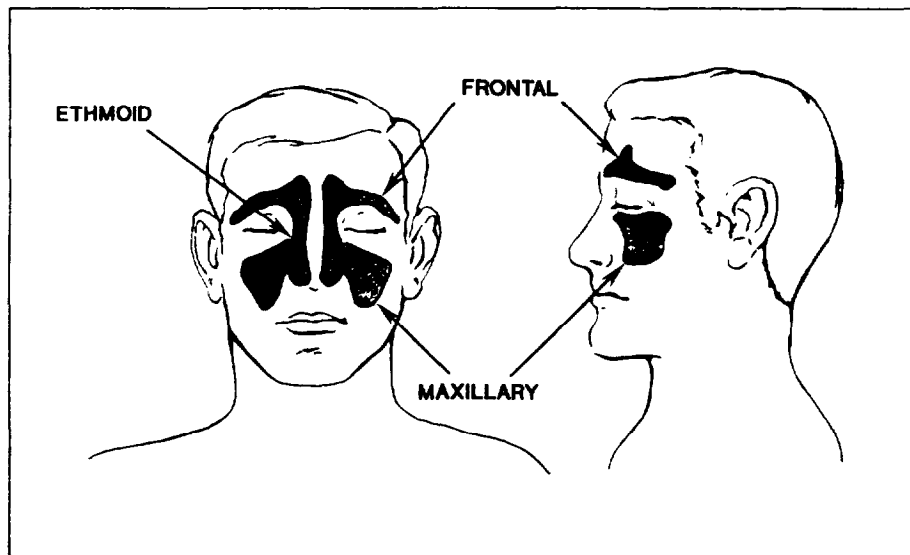

Figure 1-16. Location of sinus cavities.

If the openings into the sinuses are normal, air passes into and out of these cavities at any practical rate of ascent or descent, assuring adequate equalization of pressure. If the openings of the sinuses are obstructed by swelling of the mucous membrane lining (resulting from infection or an allergic condition) or by polyps, or redundant tissue, equalization of pressure becomes impossible. Change of altitude produces a pressure differential between the inside and the outside of the cavity and causes marked pain.

Sinus blocks can occur both during ascent and descent. In about 90 percent of the cases, however, pain develops during descent. During ascent the expanding air usually forces its way out past the obstruction.

Sinus blocks most often occur in the frontal sinus (70 percent), followed in frequency by the maxillary sinus. Maxillary sinusitis may produce pain referred to the teeth of the upper jaw and may be mistaken for toothache.

Prevention of Trapped Gas Problems of the Sinuses. As with the middle ear, sinus problems are usually preventable. Aircrew members should:

1. Avoid flying with a cold or congestion.
2. Perform the valsalva maneuver frequently during descent. The opening to a sinus cavity is quite small compared to the eustachian tube; unless the pressure is equalized, extreme pain will result.
3. Avoid any further increase in altitude if any pain in a sinus is noticed on ascent.

Treatment of Trapped Gas Problems of the Sinuses.

1. If a sinus block occurs during descent, avoid further descent. The aircrew member should attempt a forceful Valsalva maneuver. If this does not clear the sinus, ascend to a higher altitude. This ascent will ventilate the sinus. Perform normal Valsalva maneuver during slow descent to the ground.
2. If the aircraft is equipped with pressure-breathing equipment, oxygen, under positive pressure, can ventilate the sinus.
3. If equalization of pressure does not occur after landing, consult the flight surgeon.

Barodontalgia

Toothache has been reported by individuals during actual or simulated flight. The altitude at which the onset of toothache usually occurs varies from 5,000 to 15,000 feet but a pain referable to a given tooth in a given individual often may show remarkable constancy in the altitude at which it first becomes manifest. The pain may or may not become more severe as altitude is increased. Pain is invariably relieved upon descent, an important feature which helps to distinguish it from pain in the upper jaw due to maxillary barosinusitis.

When first recognized, barodontalgia was thought to be due to expansion of entrapped air under restorations. Numerous investigations have experimentally produced air bubbles under

Physiology of Flight

dental restorations and exposed the individuals to low barometric pressure. No symptoms were experienced in these cases. It is now thought that gas expansion is responsible for only a very small proportion of these cases.

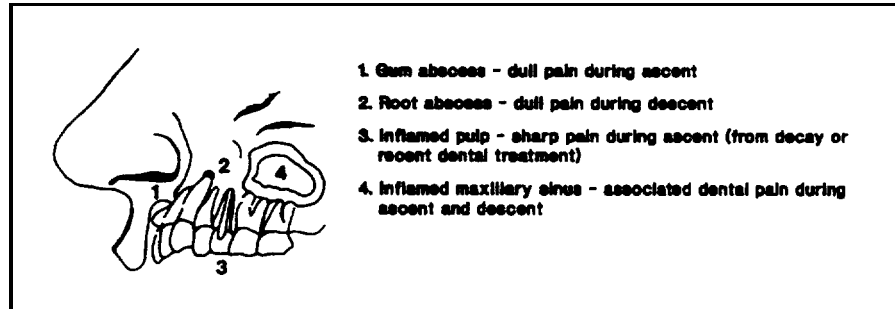

Figure 1-17. Dental problems affected by altitude.

The specific mechanism of barodontalgia has not been fully clarified but it is invariably associated with some degree of preexisting dental pathology; completely normal teeth are not affected. Imperfect fillings, pulpitis and carious teeth which were asymptomatic at ground level have all been incriminated.

Gastrointestinal Tract

Discomfort from gas expansion within the digestive tract is frequently experienced with rapid decrease in atmospheric pressure. Fortunately, the symptom is not serious in most individuals flying at low altitudes. Above 25,000 feet, however, enough distension may occur to produce severe pain. The dramatic expansion of trapped gas as altitude increases is shown in Figure 1-18.

Cause of Trapped Gas Disorders of the Gastrointestinal Tract. The stomach and the small and large intestines normally contain a variable amount of gas at a pressure approximately equivalent to the surrounding atmospheric pressure. The stomach and large intestine contain considerably more gas than does the small intestine. The chief sources of this gas are swallowed air and to a lesser degree, gas formed as a result of digestive processes, fermentation, bacterial decomposition, and decomposition of food undergoing digestion. The gases normally present in the gastrointestinal tract are oxygen, carbon dioxide, nitrogen, hydrogen, methane, and hydrogen sulfide. These occur in varying proportions, although the highest percentage of the gas mixture is always nitrogen.

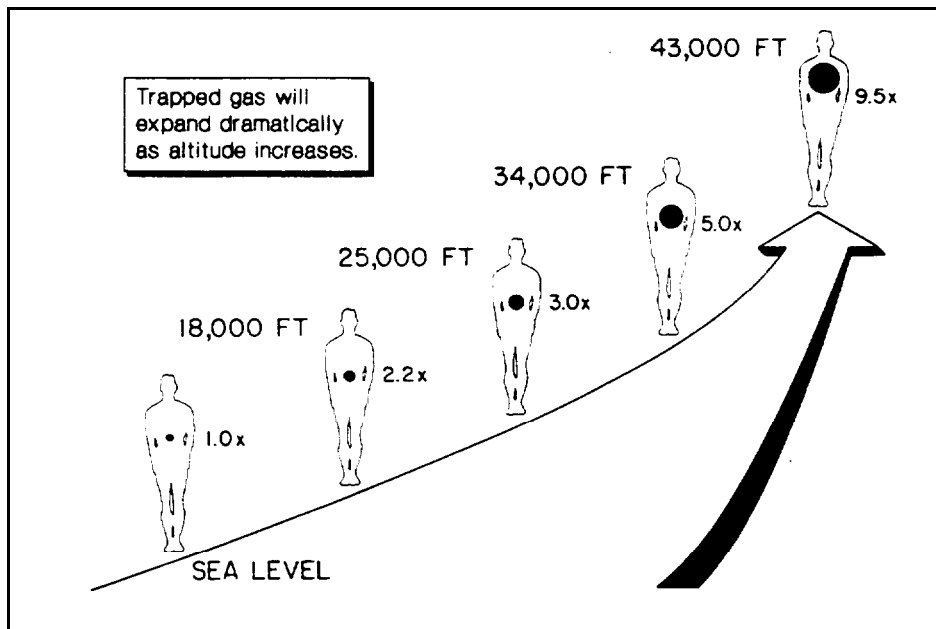

Figure 1-18. Gastrointestinal tract and trapped gas expansion at increased altitudes.

Effects of Trapped Gas Disorders of the Gastrointestinal Tract.

1. Gastrointestinal pain at high altitude may not only be caused by the absolute volume or location of the gas; sensitivity or irritability of the intestine is a more important cause. Consequently, an individual's response to high altitude varies depending upon such factors as fatigue, apprehension, emotion, and general physical condition.
2. Gas pains of even moderate severity may produce marked lowering of blood pressure and loss of consciousness if distension is not relieved.

Prevention of Trapped Gas Disorders of the Gastrointestinal Tract.

Crews should maintain good eating habits to prevent gas pains at high altitudes. Some foods that commonly produce gas are onions, cabbage, raw apples, radishes, dried beans, cucumbers, and melons. Aircrew members who participate regularly in high-altitude flights should avoid foods that disagree with them. Chewing the food well is also important. Air is unavoidably swallowed when crew members drink liquids or chew gum. Drinking large quantities of liquids, particularly carbonated beverages, before high altitude missions, and chewing gum during ascent should be avoided.

Physiology of Flight

Relief from Trapped Gas Disorders of the Gastrointestinal Tract. If trapped gas problems exist in the gastrointestinal tract at high altitude, relief is ordinarily obtained by belching or passing flatus. If pain persists, descent to lower altitude is necessary.

Bubble Related Diseases

Decompression Sickness

Decompression sickness (DCS) is defined as an illness that follows a reduction in environmental pressures sufficient to cause formation of bubbles from gases dissolved in body tissues. Decompression sickness is a true occupational disease first described in relation to syndromes which developed in caisson or tunnel workers working in closed, pressurized spaces during construction of tunnels. DCS was first described as the “bends” because of the development of lower extremity or abdominal pain causing the patient to bend over. It was also designated the “chokes” when associated with dyspnea and a choking sensation, the “staggers” when accompanied by vertigo related to inner ear disruption, and the “niggles” which refers to unusual skin sensations. Decompression sickness in naval operations is related to high altitude or underwater activities using compressed gas mixtures. Aviation decompression sickness can occur during low pressure chamber (altitude chamber) activities, flight in depressurized or unpressurized aircraft, and in high altitude high opening (standoff) parachute operations. Altitude decompression sickness is induced by exposure to ambient pressures less than sea level. It is related to altitudes usually above 18,000 feet. Aviators are protected from decompression sickness by maintaining cabin altitude via pressurization and by denitrogenation by prebreathing oxygen to reduce body nitrogen stores. Prior to flight, aviation personnel can reduce their tissue nitrogen by breathing 100 percent oxygen. Figure 1-19 shows nitrogen washout as a function of time. Currently the highest rate of altitude-related decompression sickness in naval aviation operations involves low pressure chamber activities.

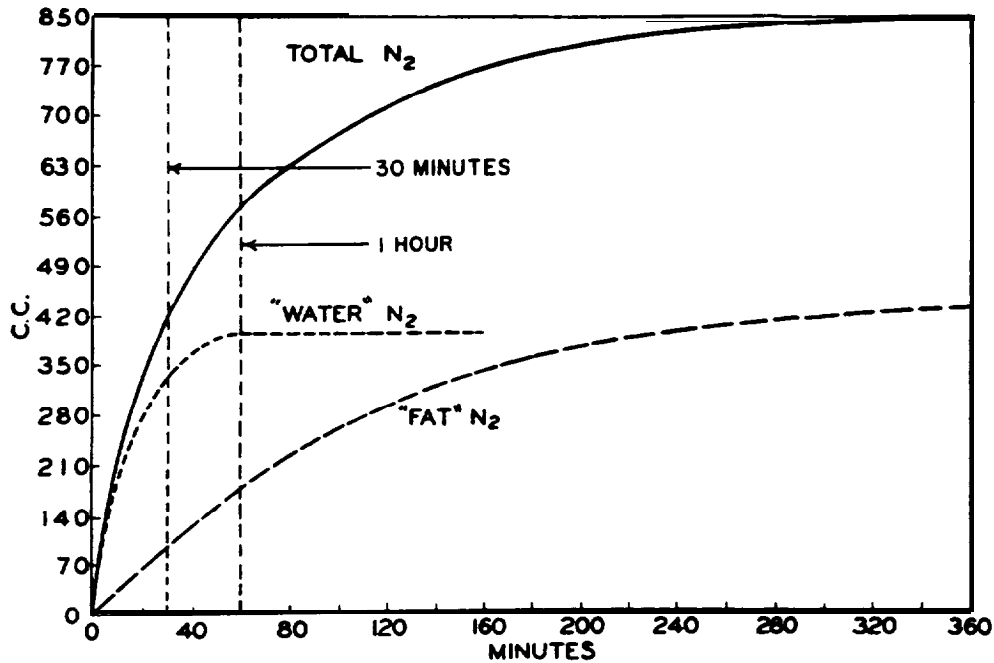

Figure 1-19. The rate at which nitrogen is eliminated from the body at sea level when pure oxygen is breathed (Clamann, 1961).

Bubble Formation Theory

Decompression sickness results from bubbles formed as dissolved gases come out of solution in tissues due to a drop in ambient pressure. The principal gas involved is nitrogen, and to a lesser extent, carbon dioxide.

As nitrogen in air is inhaled, it dissolves in the body and reaches equilibrium with the liquid phase (tissue and blood). The concentration of nitrogen dissolved is proportional to the partial pressure of nitrogen in the inhaled gas (Henry's Law). As one descends below the surface, these partial pressures increase with depth. As one ascends from depth or climbs in altitude, the partial pressures of the gases in the breathing mixture decrease. If the nitrogen partial pressure in the breathing gas is reduced or eliminated, a gradient is established across the alveoli. Nitrogen is off-gassed from the various tissue compartments, and may require 12 hours or more to reach equilibrium. The rate of inert gas uptake and elimination depends on: (1) gas concentration gradient between blood and tissue, (2) tissue blood flow, and (3) the ratio of blood and tissue gas solubilities. For example, nitrogen is five times more soluble in fat than in water. Gas uptake and elimination are expressed as tissue half times.

Physiology of Flight

The formation of bubbles is influenced by: (1) supersaturation of tissues with gaseous nitrogen, and (2) the presence of gas micronuclei. Supersaturation results when tissue inert gas tension (PN_2) exceeds ambient barometric pressure (PB). Critical supersaturation occurs when inert gas comes out of solution and forms bubbles. Early research suggested that once a critical supersaturation (constant allowable) ratio was attained, bubbles would form. Current theory suggests that supersaturation is related to a variable allowable ratio. This is influenced by time, pressure differential, and tissue nitrogen half time. Gas micronuclei may form in areas of negative hydrostatic pressure, such as in turbulent blood flow or areas of shearing action in joints. Gas micronuclei may arise de novo and are called autochthonous bubbles. Bubbles may form in blood, lymphatics or tissue. Inert gas tension is higher in capillary or venous blood than in arterial blood.

To successfully tolerate an ambient pressure reduction, a time-pressure profile must be selected which does not allow this critical ratio to be exceeded. Tabulated safe time-pressure profiles are called decompression tables.

Bubbles have two pathophysiological effects. First, the direct mechanical effects of the bubbles may result in vessel obstruction or tissue distortion, causing pain, ischemia, infarction, or dysfunction. The second effect, tissue-bubble interface surface activity, results in denaturation of proteins and aggregation of platelets, causing endothelial damage and the release of pain mediating substances. Because the bubbles may form in different places in the body, they may give rise to multifocal lesions which do not necessarily follow dermatomal or anatomical distributions.

Once the bubbles are formed, they tend to expand as dissolved gases and continue to come out of solution. Carbon dioxide, a highly diffusible gas, contributes to bubble enlargement, especially if formed in excess by vigorous exercise. For this reason, DCS patients should be kept at rest.

Decompression sickness is a progressive systemic disease. Although the initial manifestation of DCS may be of a relatively trivial nature, further expansion or formation of bubbles elsewhere may result in a life threatening situation if treatment is not initiated promptly. The various clinical syndromes may occur in any combination.

Clinical Syndromes of Decompression Sickness

Decompression sickness is classified as either Type I or Type II. This clinical classification is useful because it helps establish treatment, prognosis, and aeromedical disposition.

Type I Decompression Sickness. Type I decompression includes: (1) limb pain (musculoskeletal

symptoms, (2) skin bends (cutaneous symptoms), and (3) lymphatic bends (lymph node swelling and pain).

1. *Limb Pain.* The most common presenting symptom of DCS is pain, accounting for 60 to 70 percent of Altitude DCS, and 80 to 90 percent of dive related DCS. Joint pain is by far the most common type. But other types of pain may occur. The shoulder is the most common site of joint pain. The elbow, wrist, hand, hip, knee and ankle may also be involved. Upper extremity pain is more common than lower extremity pain (lower extremity pain is usually seen in saturation divers). The characteristic pain of Type I DCS usually begins gradually. Called the "niggles" by divers, it is slight when first noticed, and may be difficult to localize. It may be located in a joint or may be only a muscle ache. The pain tends to increase in intensity over time and is usually described as a deep, dull ache. The limb may be held preferentially in certain positions to reduce the pain intensity (guarding). The hallmark of Type 1 pain is its dull, aching quality and its confinement to particular areas. It is present at rest and may or may not be made worse with movement. The pain may be relieved by an inflated blood pressure cuff over the site. The most difficult differentiation is that Type I DCS and pain resulting from a muscle sprain or bruise.

A sharp, knife-like pain that shoots down an extremity or encircles the body trunk (radicular or dermatomal pain), thoracic or abdominal pain, tingling or burning pain (paresthesias), or pain that moves from one area to another or arises from the nervous system is treated as Type II DCS (see below). If there is any doubt as to the cause of the pain, assume that the diver or aviator is suffering from DCS and treat him accordingly. Frequently, pain may mask other more significant symptoms and a thorough neurological exam is indicated. Pain should not be treated with analgesic medication. Bilateral pain, truncal pain, or hip pain is treated as Type II DCS (see below).

2. *Cutaneous (Skin) Bends.* The most cutaneous manifestation of DCS is itching. Itching (pruritus) or crawling sensation (formication), usually occurs in dry hyperbaric (chamber) dives and does not require recompression. Mottling or marbling of the skin, known as Cutis Marmorata, is caused by venous obstruction by intravascular bubbles, and precedes the more serious forms of DCS. It usually starts as intense itching, progresses to redness, then to patches or linear areas of dark purple-blue discoloration of the skin. The skin may feel thickened and the rash may be raised. Visible skin bends (marbling) should be treated with recompression.

3. *Lymphatic Bends.* Lymphatic obstruction by bubbles may cause localized pain in the lymph nodes and swelling of the area. Recompression will usually provide prompt relief of pain. However, the swelling may take somewhat longer to resolve completely and may still be present at the completion of treatment. Lymphatic bends are rare.

Physiology of Flight

Type II Decompression Sickness. Type II DCS is the most severe form of DCS. Patients may present with neurological, cardiorespiratory, or inner ear symptoms, pain or shock. Type I symptoms may be present at the same time. Thirty to 40 percent of Type II Altitude DCS cases have associated limb pain. In Altitude DCS cases 85 to 90 percent are Type I, and 10-15 percent will be Type II DCS.

In the early stages, the symptoms of Type II DCS may not be obvious; and the patient may consider them inconsequential. The patient may feel fatigued or weak and attribute this to overwork. Even as the weakness becomes more severe, the individual may not seek treatment until walking, hearing, or urinating becomes difficult. For this reason, symptoms must be looked for during the postdive or postflight period and treated before they evolve further. Fifty percent of DCS cases present within 30 minutes, 85 percent by one hour, and only one percent after six hours.

Many of the symptoms of Type II DCS are the same as those of arterial gas embolism (AGE), although AGE usually presents within 10 minutes. The treatment for arterial gas embolism is also an appropriate treatment for DCS.

1. *Neurological Symptoms.* These symptoms may be the result of involvement at any level of the nervous system. Peripheral nervous system involvement may present with patchy peripheral paresthesias (burning or tingling) or numbness or weakness (usually mild and confined to one extremity). Spinal cord DCS may present with numbness, weakness, paralysis, or urinary dysfunction. Spinal cord DCS is more commonly the result of diving activities and accounts for less than 10 percent of Type II Altitude DCS cases.

Brain DCS is the most common form of Type II Altitude DCS. Disturbances of higher cortical function may result in personality changes, confusion, or inappropriate behavior. Hemiplegia, hemisensory loss, incoordination, or tremor may occur. Symptoms of classic migraine, with unilateral headache and scotoma, may be a presentation of Type II DCS. Headache and visual disturbances occur in 30 to 40 percent of Type II Altitude DCS. Brain DCS signs may be subtle and may be overlooked or passed off as being inconsequential. Loss of consciousness, which may be due to neurological or cardiorespiratory collapse, is a sign of fulminant DCS or AGE.

Inner ear DCS may result in vertigo, dizziness, tinnitus, and hearing loss. It may be difficult to distinguish from a round or oval window rupture. Inner ear DCS usually occurs in deep helium-oxygen dives of long duration.

Pain that is bilateral or involves the trunk or hip is considered Type II DCS. Divers who develop pain while under pressure should be treated for Type II DCS.

The occurrence of any neurological symptom following a dive or flight should be considered a symptom of Type II DCS or arterial gas embolism. Fatigue is not uncommon after long dives or flights. Fatigue that is unusually severe may be a sign of CNS involvement.

2. *Cardiopulmonary Symptoms.* If profuse intravascular bubbling occurs, symptoms of "chokes" may develop due to congestion of the pulmonary vasculature. Pulmonary DCS or "chokes" is manifested by: (1) burning substernal chest pain, often aggravated by breathing, (2) cough, and (3) shortness of breath (dyspnea). Pulmonary DCS makes up 5 to 10 percent of Type II Altitude DCS. Symptoms of increasing lung congestion may progress to complete circulatory collapse, loss of consciousness, and death if recompression is not instituted.

Factors Associated with Decompression Sickness

Altitude or Depth Attained. DCS occurring from altitude exposures below 18,000 feet is rare and usually results from other predisposing factors. In an Air Force series of Altitude DCS cases, only 13 percent occurred below 25,000 feet, and 79 percent occurred above 30,000 feet. In diving operations, DCS should not occur in water shallower than the no decompression limit. Deeper and longer dives result in DCS upon return to the surface unless a slow staged decompression back to the surface is followed. Rate of ascent (change in pressure differential) will also effect DCS incidence.

Duration of Exposure. Altitude DCS is rare in exposures of less than five minutes at altitude. Exposures of 20 to 60 minutes show an increased occurrence of DCS.

Surface Interval Prior to Reexposure. Reexposure to altitudes over 18,000 feet within three hours increases the risk of DCS. Sea level intervals of 24 to 48 hours may be required between altitude exposures to reduce the risk of DCS to baseline. U.S. Navy guidelines for low pressure chamber flights above 18,000 feet include 48 hour surface intervals, and no more than three chamber flights in a seven day period. For altitudes from 10,000 to 18,000 feet, a 24 hour surface interval is required. Surface intervals for dive operations are dependent on residual nitrogen times calculated from the dive tables.

Flying after Diving. Following hyperbaric exposure to compressed gas, a person has an excess of dissolved gas (residual nitrogen) which continues to off-gas at a predictable rate. Exposure to a hypobaric environment may accelerate this off-gassing leading to bubble formation and DCS. DCS following diving has occurred as low as 7000 feet. Following a 1600 foot deep saturation dive, team members developed DCS four days later on a commercial air flight. OPNAVINST 3710.7 states "Under normal circumstances, flight personnel shall not fly or perform low pressure

Physiology of Flight

chamber runs within 24 hours following scuba diving, compressed air dives, or high pressure chamber runs. Under circumstances where an urgent operational requirement dictates, flight personnel may fly within 12 hours of scuba diving, providing no symptoms of aeroembolism develop following surfacing and the subject is examined and cleared by a flight surgeon.”

Diving at Altitude. Diving at altitude refers to diving at elevations higher than sea level, such as mountain lakes. Current U.S. Navy dive tables are based on sea level surface. Diving at altitude may increase the DCS risk. U.S. Navy diving above 2300 feet requires CNO approval.

Prior DCS. In the diving community, prior DCS or subclinical DCS might increase the risk of DCS. Approximately five to 10 percent of Altitude DCS cases had prior DCS. Other factors such as age and injury may be confounding variables.

Occupation. Earlier studies revealed higher Altitude DCS incidence in insider observers of low pressure chambers. A recent study found identical rates in students and inside observers. Again confounding variables may be a factor.

Age. Incidence rates of DCS in those age 40 to 45 years is three times that of 19 through 25 year olds. U.S. Navy divers over 45 years old must be waived to dive and are restricted to supervisory type dives.

Gender. A recent study showed an association of DCS with female sex. The relative risk of Altitude DCS was twice that of men. Other studies have shown that DCS in women is temporarily related with the perimenstrual portion of the menstrual cycle. These results show an association, not necessarily casual, and are being further studied.

Exercise. Exercise appears to increase the incidence of DCS. Exercise leads to increased muscle perfusion, an increase in inert gas uptake, shear forces in joints causing gas micronuclei, and increased carbon dioxide which may accelerate bubble growth. Decompression time is extended for divers engaged in strenuous activity. The altitude equivalent with exercise is an additional 3000 to 5000 feet. Individuals undergoing altitude exposures over 18,000 feet should refrain from vigorous exercise for 12 hours prior to exposure and three to six hours following exposure. This will avoid predisposing factors and confusion regarding musculoskeletal pain and limb bends.

Injury. Recent injury may predispose to DCS. Although the exact mechanism is unclear, local inflammatory reaction, changes in perfusion, and gas micronuclei may be involved.

Temperature. Very cold ambient temperature increases the risk of DCS perhaps by changes in nitrogen washout from peripheral vasoconstriction.

Body Morphology. Although body weight does not affect DCS incidence, body fat does appear to be a predisposing factor, probably related to increase in tissue nitrogen stores.

Inspired carbon dioxide concentration. Increase carbon dioxide in inspired gas predisposes to DCS because of its high solubility in gas micronuclei.

Hypoxia. Hypoxia has been anecdotally related to DCS.

Personal Factors. Alcohol ingestion, dehydration, and fatigue have anecdotally been associated with DCS.

Arterial Gas Embolus. Dive profiles conducive to arterial gas embolus (bouyant ascent) may produce a nidus of bubble nuclei into which dissolved gases could diffuse where they would have otherwise remained in solution.

Venous Gas Embolus and Atrial Septal Defects. Venous bubbles are detected by precordial doppler ultrasound following reduction in ambient pressures in otherwise asymptomatic people. These venous gas bubbles are normally filtered from the pulmonary circulation by the lung. Several recent articles have implicated atrial septal defects such as a patent foramen ovale as predisposing to DCS by allowing these otherwise silent venous bubbles to pass into the arterial circulation where they are spread throughout the body. Patent foramen ovale, detected with bubble contrast ultrasound techniques, has been detected in significantly higher numbers of Type II DCS cases where the dive profile was not likely to cause DCS (undeserved DCS). Patent foramen ovale has also been implicated in Altitude DCS cases.

Altitude Decompression Sickness Versus Diving Decompression Sickness.

The cause, clinical effects, and treatment of these two syndromes are identical. However, altitude DCS tends to result in cerebral lesions, whereas DCS occurring during diving is more likely to involve lesions of the spinal cord. The reason for this difference is unknown. It is important to note that the entire spectrum of clinical manifestations is possible in either type.

Differential Diagnosis of Altitude Decompression Sickness.

1. Musculoskeletal (non-DCS) limb pain.
2. Hypoxia.
3. Hyperventilation.
4. Carbon monoxide poisoning.
5. Spatial disorientation.

Physiology of Flight

6. Air sickness.
7. Trapped gas abdominal distension.
8. Alternobaric vertigo.
9. Perilymph fistula.
10. Acceleration atelectasis.
11. Spontaneous pneumothorax.
12. Migraine syndrome.
13. Entrapment neuropathy.
14. Cervical radiculopathy.

Pulmonary Overinflation Syndromes

The pulmonary overinflation syndromes are barotrauma disorders caused by gas expanding within the lung, resulting in alveolar rupture. The syndromes encountered include arterial gas embolism, pneumothorax, mediastinal emphysema, subcutaneous emphysema, and rarely pneumopericardium.

Alveolar rupture may result from excessive positive pressure (failed regulator) or failure of gas to escape from the lung during ascent. This may occur from voluntary breath holding during a panic ascent or from localized pulmonary obstruction (asthma, secretions, and calcification). Pulmonary bullae are particularly susceptible to alveolar rupture.

Arterial Gas Embolism

Arterial gas embolism is caused by entry of gas emboli into the arterial circulation where they are dispersed throughout the body. The organs susceptible to arterial gas embolism, the CNS and heart, are responsible for life threatening symptoms. In all cases of arterial gas embolism, pneumothorax is a possibility.

Symptoms of arterial gas embolism are likely to show up within a minute or two after surfacing. Any CNS symptom other than unconsciousness which occurs much later than 10 minutes after surfacing is rarely the result of arterial gas embolism. Anyone who has obtained a breath of compressed gas from any source at depth, whether from diving apparatus, Helicopter Emergency Escape Device (HEEDS) bottle, or a diving bell, and who is unconscious or loses consciousness within 10 minutes of reaching the surface, must be assumed to be suffering from arterial gas embolism. Recompression therapy must be started immediately.

Characteristics of Arterial Gas Embolism

Sudden Onset. The onset is usually sudden and dramatic, often occurring within seconds after arrival on the surface or even before reaching the surface. The signs and symptoms may include dizziness, paralysis, weakness in the extremities, large areas of abnormal sensation, blurring of vision, or convulsions. During ascent, the diver may have noticed a sensation similar to that of a blow to the chest. The victim may become unconscious without warning and may even stop breathing.

Similarity to DCS. Some of these symptoms may also be experienced by a diver suffering from DCS. If the dive has been to a depth of less than 33 feet, DCS is unlikely and arterial gas embolism must be assumed. If the only symptom described is pain, arterial gas embolism is unlikely. DCS or one of the other pulmonary overinflation syndromes, which are not usually acute emergencies, should be considered.

Masking of Symptoms. Some symptoms may be masked by environmental factors or by other less significant symptoms. A diver who is chilled may not be concerned with numbness in an arm which may actually be a sign of nervous system involvement. Pain from any source may divert attention from other symptoms. The natural anxiety that accompanies a "close call," such as the failure of the diver's air supply, or egress from a helicopter lost at sea, might mask a state of confusion caused by an arterial gas embolism to the brain. A diver coughing up blood or bloody froth may be showing signs of ruptured lung tissue, or he may merely have bitten his tongue or experienced a case of sinus squeeze.

Spontaneous Improvement. Symptoms of arterial gas embolism may improve spontaneously without treatment. If left untreated, these symptoms may recur with increased severity. Even if the symptoms resolve, treat the diver as if symptoms were still present.

Arterial Gas Embolus Versus Decompression Sickness

At times it may be difficult to distinguish arterial gas embolism from DCS. The treatment for arterial gas embolism is usually longer and deeper than that for DCS because the danger from brain damage is so much greater. Recompression treatment for arterial gas embolism will also be adequate treatment for DCS. If there is any doubt as to the correct diagnosis, assume arterial gas embolism. Although both DCS and AGE may present within minutes of reaching the surface, symptoms presenting after 10 minutes are not consistent with AGE. AGE usually presents with substantial neurological symptoms localized to brain or higher cortical centers. If spinal cord symptoms are present, it is more likely DCS. Certain dive profiles (short, shallow dives) are not

likely to cause decompression sickness and would be more consistent with AGE (i.e., HEEDS training). Ascents from depth that are uncontrolled are more consistent with AGE. A patient with other signs of Pulmonary Overinflation Syndromes (POIS) is more likely to have AGE.

Other Pulmonary Overinflation Syndromes

Expanding gas trapped in the lung may enter tissue spaces causing mediastinal emphysema, subcutaneous emphysema, pneumothorax, and pneumopericardium. Tension pneumothorax may be life threatening requiring thoracostomy. Mild pneumothorax may respond to 100 percent O₂. Pneumopericardium is rare. It is generally reported only on radiographs. Recompression therapy is not necessary for emphysema or pneumothorax, and may convert a simple pneumothorax into a tension pneumothorax.

Treatment of Bubble Related Disorders

Recompression Therapy. The only satisfactory treatment for DCS or AGE is recompression therapy. Medical therapy and observation only have an adjunctive role in the management of DCS or AGE once the diagnosis is made. Once the diagnosis is made, the patient should be transported as quickly as possible to a recompression chamber where appropriate therapy can be administered according to current protocols (NAVSEA 0094-LP-001-9010). Chamber personnel are well trained in applying these therapeutic methods to patients with DCS and AGE.

A brief synopsis of these methods is included here. Actual recompression therapy must be administered by trained chamber personnel in accordance with Navy diving procedures.

Air Treatment Tables. A treatment table is a time- pressure profile applied in a recompression chamber to treat patients with DCS and other dysbaric illnesses. The pressure is measured in Feet Sea Water (FSW). There are two basic types of treatment tables, those using air only, and those where 100 percent oxygen is available in the chamber. The first treatment tables introduced were air tables. Patients treated with air tables are pressurized in an air atmosphere while breathing the air in the chamber. Although these patients receive the benefits of pressure, they also take up additional nitrogen during the treatment which must be removed by slow decompression. Therefore, air tables are quite lengthy.

Oxygen Treatment Tables. The more recently developed oxygen treatment tables pressurize the patient with air, but oxygen is available for breathing by mask (Built in Breathing System or BIBS). Oxygen breathing provides several advantages. The increased oxygen partial pressure provides life-sustaining oxygen to tissues compromised by bubbles. No nitrogen is inhaled by the pa-

tient so an increased alveolar nitrogen gradient is created to remove nitrogen from the body. Also, no additional nitrogen is dissolved in the patient's tissues. During the treatment this permits a more rapid reduction of pressure, or ascent, from treatment depth to the surface. As oxygen tables are considerably shorter, there is less risk of DCS to the inside tenders. Oxygen Tables are superior to the older air tables, and should be used whenever possible. A disadvantage of oxygen tables is that oxygen toxicity may occur. The oxygen treatment tables include air breaks (five minute interruptions when air is breathed instead of oxygen) to reduce the likelihood of oxygen toxicity. Acute oxygen toxicity causes increased irritability of the CNS. Symptoms of CNS oxygen toxicity include visual abnormalities (such as tunnel vision), tinnitus, nausea, twitching, irritability, dizziness, and seizures. When oxygen tables are used, the inside tenders (the medical observers inside the chamber) breathe oxygen during part of the treatment to reduce their tissue nitrogen tension and minimize their risk of bends.

Indications for Hyperbaric Oxygen Therapy

The oxygen treatment tables are useful in treating a variety of nondiving illnesses, such as carbon monoxide toxicity, cyanide poisoning, gas gangrene, and smoke inhalation. The increased oxygen tension will help displace these toxins by mass action. Additionally, enough oxygen will dissolve in serum that significant anemic states can be overcome (serum pressurized to 60 FSW can support life without red cells or hemoglobin). NAVMEDCOMINST 6320.38A limits the use of the US Navy hyperbaric chambers for nondiving illness to carbon monoxide toxicity, cyanide poisoning, gas gangrene, iatrogenic gas embolism, and smoke inhalation. Other uses require prior approval from the Chief, Bureau of Medicine and Surgery. In addition, the Undersea and Hyperbaric Medical Society has approved recompression therapy for radiation necrosis, refractory osteomyelitis, selected burns, nonhealing wounds, failing skin flaps and grafts, necrotizing soft tissue infection, acute anemia, and crush injuries. A number of disorders, such as Multiple Sclerosis and stroke, have been treated with recompression therapy in experimental settings.

Indications for Specific Treatment Tables

The treatment tables (Table 1-13) were given arbitrary numerical names as they were historically developed. The treatment tables a flight surgeon should be familiar with are Treatment Tables 4, 5, 6, 6A, and 7.

Table 1-13

List of U.S. Navy Standard Recompression Treatment Tables

TABLE		USE
TABLES USED WHEN OXYGEN AVAILABLE		
4	Air/Oxygen Treatment of Type II Decompression Sickness or Gas Embolism	Treatment of worsening symptoms during the first 20-min oxygen breathing period at 60 feet on Table 6 or unresolved arterial gas embolism symptoms after 30 min at 165 feet.
5	Oxygen Treatment of Type I Decompression Sickness	Treatment of Type I decompression sickness when symptoms are relieved within 10 minutes at 60 feet and a complete neurological exam was done and is normal.
6	Oxygen Treatment of Type II Decompression Sickness	Treatment of Type II decompression sickness or Type I decompression sickness when symptoms are not relieved within 10 minutes at 60 feet.
6A	Air and Oxygen Treatment of Gas Embolism	Treatment of gas embolism symptoms relieved within 30 min at 165 feet. Use also when unable to determine whether symptoms are caused by gas embolism or severe decompression sickness.
7	Air and Oxygen Treatment of Life Threatening or Extremely Serious Symptoms	Treatment of unresolved severe symptoms at 60 feet after initial treatment on Table 6, 6A or 4. Used only in consultation with a Diving Medical Officer.
TABLES USED WHEN OXYGEN NOT AVAILABLE		
1A	Air Treatment of Type I Decompression Sickness—100-foot Treatment	Treatment of Type I decompression sickness when oxygen unavailable and pain is relieved at a depth less than 66 feet.
2A	Air Treatment of Type I Decompression Sickness—165-foot Treatment	Treatment of Type I decompression sickness when oxygen unavailable and pain is relieved at a depth greater than 66 feet.
3	Air Treatment of Type II Decompression Sickness or Gas Embolism	Treatment of Type II symptoms or gas embolism when oxygen unavailable and symptoms are relieved within 30 min at 165 feet.
4	Air Treatment of Type II Decompression Sickness or Gas Embolism	Treatment of symptoms which are not relieved within 30 min at 165 feet using Air Treatment Table 3.

NOTE: 1 Always use Oxygen Treatment Tables when oxygen available.
 2 Helium-oxygen may be used in lieu of air on these treatment tables upon the recommendation of a Diving Medical Officer.

Treatment Table 5 - Type I DCS Only. Treatment Table 5 (TT 5) in Figure 1-20 is an oxygen table used to treat Type I DCS. At two hours and 15 minutes, it is the shortest table. The patient

is pressurized to 60 FSW for two oxygen periods, brought to 30 FSW for one additional oxygen period, and slowly brought to the surface. The patient also breathes oxygen while changing depths. Five minute air breaks between oxygen periods prevent CNS oxygen toxicity.

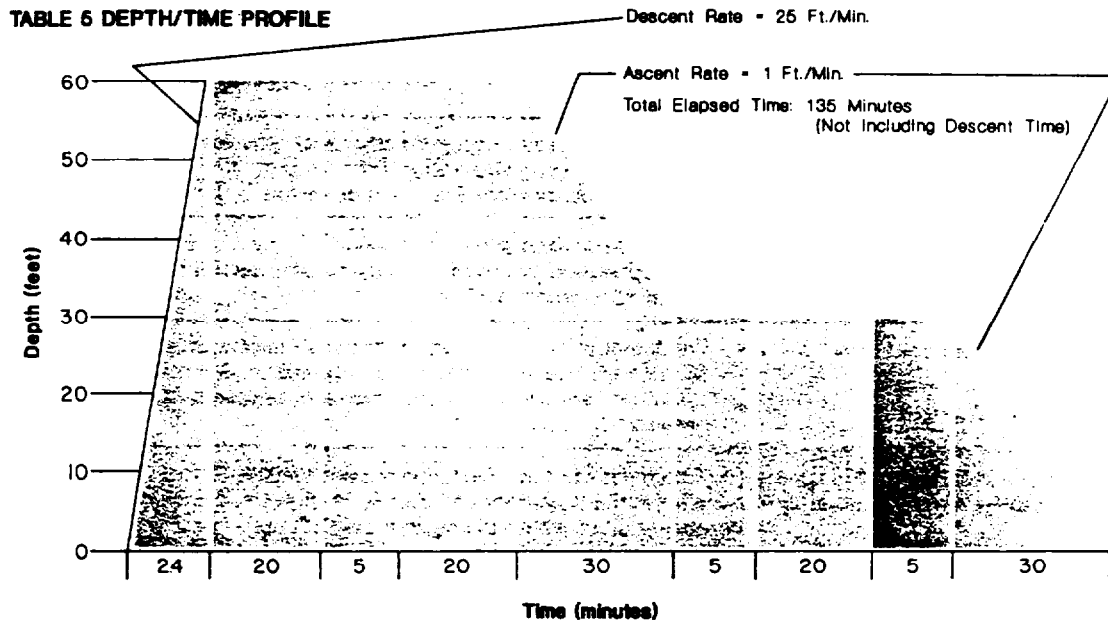

Figure 1-20. Treatment Table 5.

Treatment Table 6 - Type II DCS (Except Inner Ear DCS), Type I DCS with Pain Over 10 Minutes at Depth on TT5. if the Type I symptoms do not resolve within 10 minutes at 60 FSW or if the patient has Type II DCS, treatment is completed using Treatment Table 6 (Figure 1-21), (the patient is "brought out" on Treatment Table 6). This oxygen table lasts four hours and 45 minutes. It is similar to Treatment Table 5 except the times at 60 FSW and 30 FSW are increased. Additionally, if clinically indicated (i.e., if symptoms are not resolved), Treatment Table 6 may be lengthened. A total of four additional time periods, called extensions: two at 60 and two at 30 feet may be administered as needed.

TABLE 6 DEPTH/TIME PROFILE

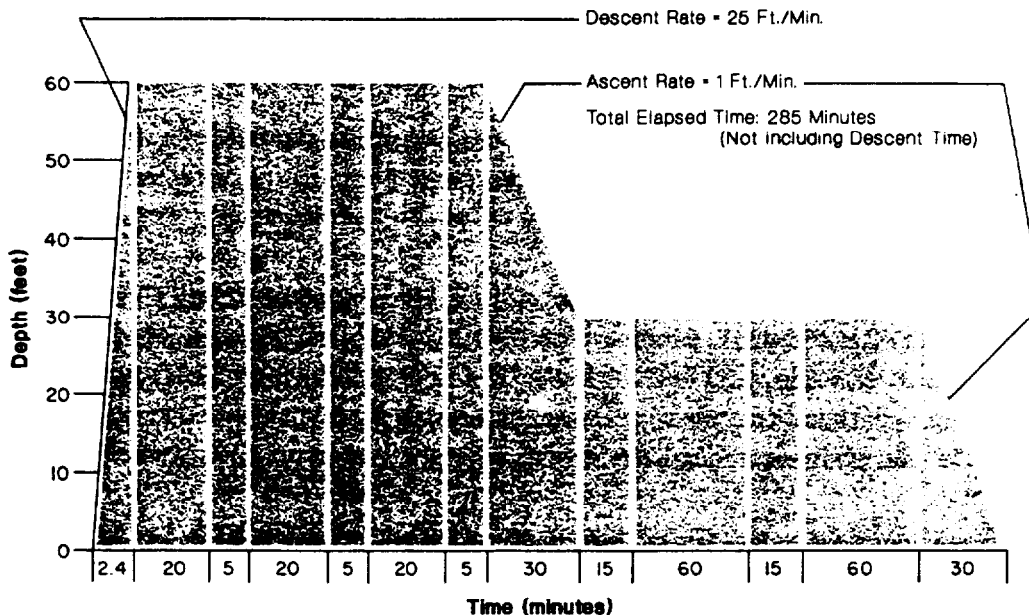

Figure 1-21. Treatment Table 6.

Treatment Table 6A - AGE, Inner Ear DCS. Treatment Table 6A is used to treat arterial gas embolism. Treatment Table 6A is just like Treatment Table 6, except the patient is first brought to 165 FSW for 30 minutes on air to compress intra-arterial bubbles as much as possible. Oxygen cannot be used at this depth because of oxygen toxicity. After the initial period of deep recompression, the patient is brought to 60 FSW. The rest of the treatment is like Treatment Table 6.

Treatment Tables 4 and 7. For very sick patients two additional tables are available, Treatment Tables 4 and 7. Treatment Table 4 is used to treat symptoms refractory to treatment at 60 feet by increasing the depth to 165 feet. Treatment Table 4 is also used to allow gas embolism patients more time at 165 feet than permitted by Treatment Table 6. Oxygen cannot be used until the patient reaches 60 feet. Because the tissues become nitrogen-saturated due to the extended time at depth, the patient must be brought to the surface very slowly. Treatment Table 4 takes 38 hours and 11 minutes to complete, and is basically an air saturation decompression table.

For the patient with life-threatening DCS unresponsive to treatment, the option of Treatment Table 7 is available. This table provides for maximal treatment time at 60 feet. The treatment includes a stay at 60 feet of at least 12 hours, with an extremely gradual saturation-type ascent

lasting 36 hours. There is no upper limit on the time the patient may be kept at 60 feet. Treatment Table 7 should be used only by a Diving Medical Officer who has support personnel and other assets readily available to properly execute treatment.

Treatment Tables 4 and 7 are not used to treat minor neurological deficits which persist during treatment with Treatment Table 6 or 6A. Instead, these patients are retreated daily until symptoms no longer improve.

Twenty-four hour consultation is available with the Experimental Diving Unit at Panama City (NEDU) (AUTOVON 436-4351, Commercial (904) 234-4351) or the Naval Medical Research Institute (NMRI) at Bethesda, MD (AUTOVON 295-1839, Commercial (202) 295-1839) for questions regarding hyperbaric treatment or triage. Questions on Hyperbaric Oxygen therapy (HBO) for nonbubble related diseases may be referred to Wright Patterson AFB Medical Center at (513) 257-8603.

Triage and Referral of Altitude DCS Patients

All patients with Type II DCS must be recompressed urgently or evacuated promptly for hyperbaric treatment.

Patients with Type I DCS should be closely questioned about the onset of their symptoms. Patients whose symptoms appear at altitude, then resolve spontaneously on descent, should be placed in 100 percent oxygen and observed for two hours for evidence of presentation or recurrence of DCS. After two hours of observation, they are grounded for one week and returned to light duty. They must be warned to seek treatment promptly if any symptoms reoccur. Any recurrence must be treated with hyperbaric therapy.

Patients who first develop Type I symptoms at ground level after flight, or whose symptoms start at altitude and persist at ground level, must be placed on 100 percent oxygen while recompression or evacuation is arranged. If symptoms resolve while awaiting transportation, evacuation is postponed; and, these patients are observed on 100 percent oxygen for 24 hours. Any recurrence must be treated with hyperbaric therapy. Patients who remain symptom-free for the 24 hour observation period are grounded for one week and placed on limited duty with no physical training for at least 72 hours. They are advised to return promptly for reevaluation if symptoms recur. Current U.S. Navy diving medicine protocols are to treat all patients referred for altitude DCS regardless of whether or not their symptoms have resolved. Therefore, once patients are evacuated, they will be treated.

Aeromedical Evacuation

The chapter on aeromedical evacuation contains a more thorough discussion of evacuation procedures. However, some points specific to evacuation of hyperbaric patients bear mentioning.

First, the flight surgeon should know the location of the nearest recompression chambers, and how to contact personnel there. Contact should be made and the case discussed prior to transport or concurrently with transport. The aircraft should be pressurized to an altitude of 500 feet or less to prevent further bubble formation and expansion. The patient should be placed on 100 percent oxygen if available. Earlier guidelines recommended placing the patient with AGE in the left lateral decubitus position with the head down during transport, apparently to keep the bubbles from the head and heart. This may have the effect increasing intracranial pressure and reducing ventilation. The supine position is appropriate in an alert person. However, an unconscious person may be placed in the lateral decubitus position to prevent aspiration. The patient should be supine, neck in the neutral head position, and uncramped with the extremities uncrossed. The patient should also be placed so that the face is visible to the tender. The patient should not be permitted to sleep, so that changes in neurological status will be readily detected. Intravenous fluids, such as Ringers Lactate or normal saline, should be used. Free water solutions such as D5W should be avoided as they may contribute to cerebral swelling. A plastic IV bag may be used as a pillow. This will also serve to maintain the IV. Dexamethasone, while controversial, can be given 10 mg IV stat followed by 4 mg IV or IM q6hr. Inflatable cuffs, such as endotracheal cuffs, should be filled with water, not air.

Flying After Diving

Required intervals between diving and flying are given in Table 1-14.

Table 1-14

Flying After Diving

<i>Category</i>	<i>Surface Interval Before Flight</i>
Flight Crew	24 hours
Divers	
No-Decompression Dive	12 hours
Decompression Dive (nonsaturation)	24 hours
Saturation Dive	72 hours

Aeromedical Disposition

Once the patient has been diagnosed, evacuated, and treated, the question arises as to their flight status. All Type I patients should be grounded for one week; Type II patients for one month. The flight surgeon should conduct a complete fitness to continue physical examination. The aeromedical disposition is made based on diagnosis, classification, treatment course, and duty status.

Any documented history of gas embolism should be worked up for pulmonary bullae and other causes of Pulmonary Overinflation Syndrome as well as for atrial septal defects. Any persistent neurological sequelae of DCS or AGE are considered disqualifying.

Type II DCS or recurrent Type I DCS is considered disqualifying. However, designated personnel may be considered for a waiver.

Type I DCS, single episode, is considered disqualifying in nondesignated personnel. Waivers may be considered.

All requests for waivers should be forwarded to the Naval Aerospace Medical Institute (NAMI) Code 42, for consideration by the Hyperbaric Medicine Committee.

Observation Time and Travel Restrictions Following Hyperbaric Recompression

The required intervals between the completion of recompression treatment and travel in pressurized nontactical aircraft are given in Table I-15.

Physiology of Flight

Table 1-15

Time Following Completion of Recompression Treatment

<i>Condition</i>	<i>Time on Station</i> (5 min away)	<i>In Local Area</i> (30 min away)	<i>May Fly After</i> (as passengers)
Type I DCS	2 hrs	24 hrs	24 hrs
Type II DCS	6 hrs	48 hrs	48 hrs
DCS/AGE Treated on TT 6A/4/7	12-24 hrs	72 hrs	72 hrs
DCS/AGE with residual symptoms	12-24 hrs	72 hrs and cleared by DMO	72 hrs and cleared by DMO
Inside Tender on TT 5/6/6A		12 hrs	12 hrs
Inside Tender on TT 4/7		48 hrs	48 hrs

Oxygen Toxicity

The need for oxygen to sustain life at any altitude is indisputable. However, excessive amounts of oxygen or excessively high oxygen partial pressures can be detrimental or even fatal. The amounts of oxygen and oxygen partial pressures breathed by aviation personnel are usually not great enough to cause significant harm to the body. However, the problem of oxygen toxicity is more significant in underwater and hyperbaric operations where the partial pressures of the breathing gases are excessive.

The harmful effects of elevated partial pressures of oxygen are directly related to the level of elevation of partial pressures and the duration of exposure. There are several types of oxygen toxic effects known to occur in man.

Pulmonary Oxygen Toxicity

There is a risk of pulmonary oxygen toxicity whenever there is prolonged exposure (in excess of 12 to 15 hours) to inspired partial pressures of oxygen of 0.5 ATA or more. It is sometimes called the Lorraine Smith Effect after the researcher who first described it. Pulmonary oxygen toxicity begins with a progressive hydration or fluid accumulation of the lungs under hyperoxic conditions. The pulmonary edema leads to greater mechanical difficulties in ventilation together with impaired gas transfer. The individual finds it harder to breathe; he may feel a deep substernal pain and if not returned to a subtoxic breathing mix he may become hypoxic as the alveolar walls swell and the edema further impairs oxygen diffusion. Thus a paradoxical situation is reached in which elevation of the oxygen level in the gas ventilating the lungs actually decreases blood oxygenation in the pulmonary capillaries.

Pulmonary oxygen toxicity can progress to a point where hypoxia can result in death unless the alveolar oxygen pressure is elevated to increase the oxygen diffusion gradient to elevate the arterial oxygen pressure. This does provide temporary relief but also causes further edema, a further reduction in the oxygen diffusion capacity and an eventual return to hypoxia until a still higher inspired oxygen pressure is required and so the subject enters a vicious cycle which can only terminate in death. The only known treatment for pulmonary oxygen poisoning is reduction of the inspired oxygen partial pressure to less than 0.5 ATA. Endotracheal intubation and positive end-expiratory pressure ventilation (PEEP) may be necessary in severe cases to allow adequate oxygenation with oxygen partial pressure of less than 0.5 ATA.

Central Nervous System Oxygen Toxicity

The onset of neurological oxygen toxicity can be quite sudden and dramatic. It is manifested by generalized convulsions, indistinguishable from the convulsions of grand mal epileptic seizure. Central nervous system oxygen toxicity usually occurs when an individual is exposed to inspired oxygen partial pressures about 1.5 to 2.0 ATA. Other manifestations of CNS oxygen toxicity include dizziness, nausea, tunnel vision, blindness, unusual fatigue, anxiety, confusion, and a lack of coordination in movement. Muscular twitching - particularly lip twitching - can precede a convulsion but no reliance can be placed on this as an early warning. If one displays any signs of CNS oxygen toxicity, the first and most important step in treatment is to quickly switch the victim to air breathing. Chamber depth should not be altered until the victim's signs or symptoms have cleared.

Acceleration Atelectasis

Another oxygen effect which may be loosely grouped under the general heading of oxygen tox-

Physiology of Flight

icity is atelectasis while breathing 100 percent oxygen during + G_z acceleration, although the term "oxygen toxicity" in this context is a misnomer. Acceleration atelectasis is included in this section only because it occurs when an aviator is breathing 100 percent oxygen. The primary factor responsible for the atelectasis is probably the complete cessation of basilar alveolar ventilation under acceleration. There is also markedly increased blood flow to the basilar alveoli as opposed to the apical ones, along with a reduction in basilar alveolar volumes as the weight of the lung under acceleration compresses the bases against the diaphragm. With these factors acting in concert, and when the alveoli in question contain only oxygen, water vapor, and carbon dioxide, oxygen absorption (the main cause of acceleration atelectasis) leads to alveolar collapse, and atelectasis can occur very rapidly.

If nitrogen is present in the inspired gas, the gas absorption and consequent alveolar collapse are greatly slowed. The time required for complete absorption of gas contained in the lower quarter of the unventilated lung, with normal blood flow distribution, is increased from five minutes on 100 percent oxygen to about 25 minutes on 50 percent oxygen, 50 percent nitrogen. In addition, there is evidence that nitrogen in the lung acts as a "spring" by preventing alveolar collapse when all the oxygen is absorbed.

Pulmonary atelectasis during flight may result in several performance-degrading effects, including distracting or perhaps even incapacitating cough and chest pain and arterial hypoxia due to the shunt of venous blood through the nonaerated alveoli. The Flight Surgeon should remain aware that coughing, substernal pain, and decreased altitude tolerance may indicate the development of this condition. In any event, acceleration atelectasis usually resolves itself in a few days with little or no treatment.

Oxygen Paradox

Restoration of normal alveolar oxygen tension in a hypoxic individual may be accompanied by a temporary increase in severity of symptoms, a phenomenon known as "oxygen paradox." Like atelectasis, oxygen paradox may be loosely grouped under the heading of oxygen toxicity only because it also occurs when an aviator is breathing 100 percent oxygen. The paradox occurs when reoxygenation is brought about suddenly and in severe cases it can result in muscle spasms and unconsciousness which may last from a few seconds up to a minute. Usually this condition is transient and may pass unnoticed. Accompanying effects are decreased vision, mental confusion, dizziness and nausea. The mechanism responsible for this condition is uncertain, but is thought to be due to a combination of factors which include the effects of hypocapnia, the loss of the PO_2 dependent stimulation of the aortic and carotid peripheral chemoreceptors, and hypotension.

A decrease in arterial PO_2 is a potent stimulus to the carotid and aortic chemoreceptors to cause hyperventilation. The hyperventilation response due to decreased PO_2 as a result of aortic and carotid stimulation results in hypocapnia. The ensuing hypocapnia leads to cerebral vasoconstriction and systemic vasodilation. In addition the hyperventilation results in a respiratory alkalosis shifting the oxyhemoglobin dissociation curve upward and to the left (Bohr Effect). This shift increases the capacity of the blood to onload oxygen in the lungs but restricts offloading of oxygen at the tissue level. The combined effects of vasodilation of blood vessels in the extremities, vasoconstriction of cerebral blood vessels, and the shift of the oxyhemoglobin curve to the left reduces blood flow and oxygen supply to the brain (stagnant hypoxia).

Upon restoration of oxygen, there is a reduction or cessation of breathing and a hypotension. The reduction or cessation of ventilation (apnea) results from the loss of the PO_2 dependent stimulation of the carotid and aortic peripheral chemoreceptors. With the administration of 100 percent oxygen following hypoxia, arterial PO_2 increases, removing or reducing the one and only stimulus to respiration. The result is a reduction in breathing or a sudden onset of apnea. The hypotension produced by the restoration of oxygen is probably due to vasodilation, which occurs by the direct action of oxygen on the pulmonary vascular bed.

The hypocapnic effects of hypoxia and the apnea or reduction of ventilation and hypotension which follow reoxygenation, combine to further reduce cerebral blood flow. This further reduction in blood flow in all probability intensifies an already existing cerebral hypoxia for a short period of time until the cardiovascular effects have passed and carbon dioxide tension returns to normal. Once arterial carbon dioxide tension returns to normal, it will stimulate the central respiratory chemoreceptors to resume ventilation and resolve the cerebral hypoxia.

Oxygen Equipment

The ability to offset the physiological effects of reduced barometric pressure is as important to the effectiveness of a mission as the aircraft itself. Without compensation, man becomes the weak link in mission performance. Oxygen equipment is one area of development that has enabled man to fly in the environment above 10,000 feet.

Aircraft Oxygen Systems

Aircraft oxygen systems provide the aircrew member with diluted or 100 percent oxygen for breathing. Aircraft oxygen systems installed in naval aircraft fall in one of the following categories:

1. Gaseous oxygen systems.

Physiology of Flight

2. Liquid oxygen systems.
3. Onboard oxygen generation systems.

Gaseous Oxygen System. Gaseous oxygen systems are used primarily in emergency oxygen systems and in multiplace aircraft where space and weight considerations are less important. Aviators' breathing gaseous oxygen is designated "Grade A, Type I", and must meet military specifications MIL-0-27210 for purity and moisture content. Aviators' breathing gaseous oxygen must be 99.5 percent oxygen by volume and contain no more than 0.02 milligrams of water vapor per liter at sea level and 70° F. It must be odorless and free from contaminants including drying agents. "Aviators" breathing oxygen is not the same and should not be confused with "medical oxygen." While medical oxygen is more than adequate for breathing, it usually contains excessive amounts of water vapor. Air containing a high percentage of moisture can be breathed indefinitely without any serious ill effects. However, the moisture affects the aircraft oxygen system in the small orifices and passages in the regulator; freezing temperatures associated with ascent to altitude can clog the system with ice and prevent oxygen from reaching the user. Therefore, extreme caution must be taken to safeguard against the hazards of water vapor in oxygen systems.

1. *Low Pressure System.* Low pressure systems like the portable breathing oxygen cylinder and regulator type MA-1, are self-contained portable breathing devices capable of supply breathing oxygen to flight personnel for normal or emergency use. In these systems, the breathing oxygen is stored in a yellow, lightweight, nonshatterable cylinder. Shatterproofing is accomplished by heat treating or welding metal bands around the cylinder. On the side of the cylinder painted in black letters are the words "Breathing Oxygen, Nonshatterable". The cylinders have an operating pressure range of 50 to 500 pounds per square inch (psi). If the cylinder is empty it must be purged to eliminate moisture. The low pressure system reduces the possibility of explosion. However, the system is not extremely efficient since the low pressure limits the volume of oxygen.

2. *High Pressure Systems.* Aviator's breathing oxygen supply cylinders can be readily identified by their green color and 3-inch wide band around the upper circumference of the cylinder. "OXYGEN, AVIATOR'S" shall be stenciled in white parallel to the longitudinal axis and on diametrically opposed sides in letters 1 3/4 to 2 inches high. High pressure systems have an operating pressure of 50 to 1800 psi. Cylinders depleted to a pressure of approximately 50 psig shall be marked "EMPTY." Cylinders which have a pressure below 15 psig shall be removed from service for vacuum and heat drying or hot nitrogen gas drying. High pressure systems may be aircraft mounted, portable, or contained in seat kits. The size of the cylinder varies with the application.

Liquid Oxygen Systems. Liquid oxygen systems are generally used in aircraft where space, weight and mission considerations are paramount. Aviators' breathing liquid oxygen is designated "Grade B, Type II", and must also meet military specification MIL-0-27210 for purity and moisture content. Liquid oxygen is a pale blue water-like liquid, extremely cold, and odorless. Liquid oxygen, commonly referred to as LOX, is normally obtained by a combined cooling and freezing process. When the temperature of gaseous oxygen is lowered to -182° F and it is under about 750 psi, it will begin to form into a liquid. When the temperature is lowered to -297° F, it will remain a liquid under normal atmospheric pressure. Once converted into a liquid, oxygen will remain in its liquid state as long as the temperature is maintained below -297° F. A liquid oxygen converter assembly is designed to store and convert liquid oxygen into gaseous oxygen. A typical liquid oxygen converter assembly (Figures 1-22, 1-23) consists of a container sphere, buildup and vent valve, relief valve, and associated tubing and fittings. A capacitance type probe assembly which sends an electric signal to a liquid oxygen quantity gauge that is located in the aircraft is incorporated within the sphere. The quantity gauge indicates the amount of LOX in liters that is contained in the converter. Oxygen in its liquid state is stored in the spherical assembly (Figure 1-22) which consists of an inner and outer shell separated by an annular space. The annular space is evacuated, creating a vacuum, preventing the transmittal of heat through the space. The thermos bottle effect created retards heating and eventual conversion of LOX to gaseous oxygen. Valves, tubing, and fittings incorporated in the converter assembly convert LOX to gas and direct its flow at a controlled rate (Figure 1-23). Most tactical jet aircraft use the removeable 10 liter LOX converter. Aircraft such as the C-9 use a 25 liter aircraft mounted LOX converter.

The potential hazards associated with the handling of liquid oxygen are due to its extremely cold temperature, rapid expansion upon conversion to gas at ambient (room) temperature, and its reactivity with any organic matter or flammable substance with which it comes in contact.

Because liquid oxygen has an extremely low temperature (Boiling point - 183 F, Storage temp. -297 F.) it can freeze or seriously damage skin tissue upon contact. Injuries to the skin resulting from contact with liquid oxygen should be treated as frostbite or similar hypothermic injuries.

Under the right conditions of temperature and pressure liquid oxygen may react violently with any organic matter, particularly that containing hydrocarbons. Mere mixture of liquid oxygen with powered organic materials under certain conditions may cause an explosion.

If liquid oxygen is vaporized and warmed to ambient temperature, one volume of liquid oxygen will expand to 862 volumes of gaseous oxygen. In the aircraft this expansion ratio results in a saving of approximately 82 percent in weight and approximately 75 percent in space. Weight and

Physiology of Flight

space are critical in a jet propelled aircraft because for every pound removed from the aircraft approximately two pounds of thrust are gained.

Liquid oxygen systems work on low pressure [110 psig max] and must be vented to prevent over pressurization. In LOX storage containers are not vented explosive pressures in excess of 12,000 psig will be created.

Liquid oxygen demonstrates a high affinity for absorption of impurities and noxious odors, resulting in contamination of complete systems. Suspected impurity contamination of liquid oxygen in aircraft systems has resulted in abortion of numerous inflight missions.

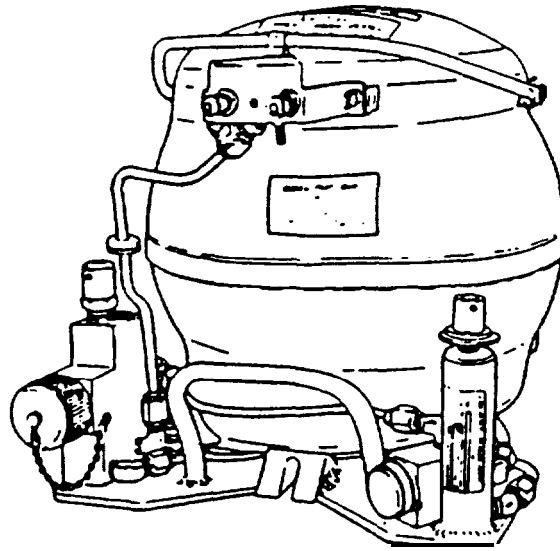

Figure 1-22. Liquid oxygen converter.

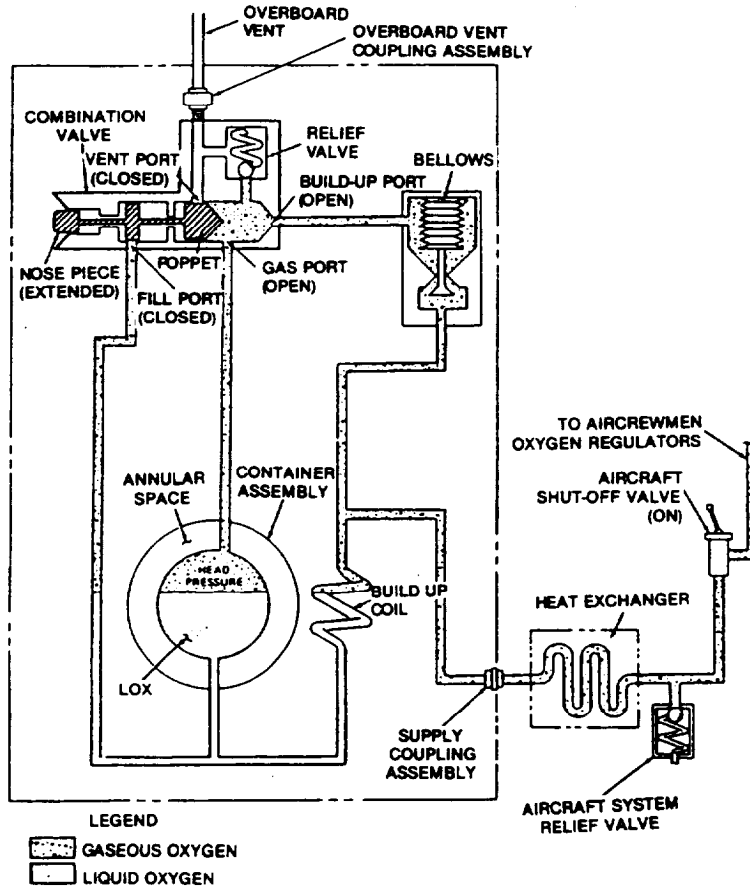

Figure 1-23. Liquid oxygen converter flow diagram.

Onboard Oxygen Generation Systems (OBOGS). The idea of producing oxygen in flight is very attractive since it minimizes logistic support for oxygen and increases operational safety. Several OBOGS systems are currently being evaluated. These systems include electrochemical concentration, fluomine chemical absorption, permeable membrane, and molecular sieve.

Currently the Navy's AV-8B Harrier aircraft utilizes the molecular sieve OBOGS. In the molecular sieve system (Figure 1-24) bleed air from the turbine engine is alternately pumped between two molecular sieve beds containing aluminosilicate crystals called zeolite. The oxygen is separated from the nitrogen and concentrated. The oxygen-enriched air is then available for use through the normal oxygen delivery system. During the separation process using the two-bed systems, as the first bed is concentrating oxygen, the second bed is removing nitrogen and releas-

ing it to the atmosphere. The cycles are then reversed with pressurization of the second bed and exhaustion of the first bed, thus producing a continuous supply of oxygen. System startup is virtually instantaneous. The enriched air supply proceeds directly as the bleed air supply pressurizes the system. When the aircraft is ready OBOGS is ready. The onboard oxygen generating system is a revolutionary oxygen system which yields a continuous supply of breathing oxygen to the aircrew member with no replenishment requirements. If there is any drawback to the system, it might be the fact that at best this system can only provide 95 percent oxygen, with 5 percent argon.

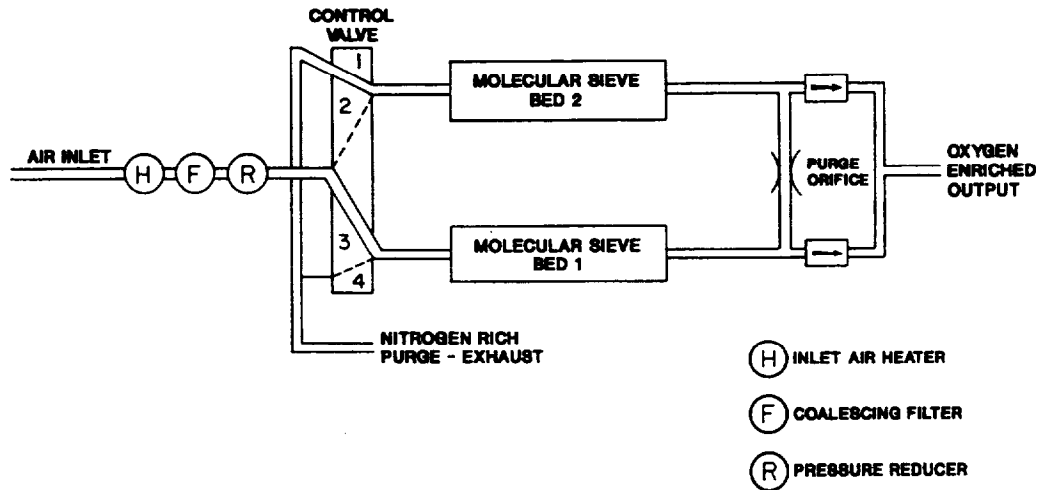

Figure 1-24. Molecular sieve oxygen-enriched air system (OEAS) schematic with inlet accessories.

Oxygen Regulators

The purpose of an oxygen regulator is to control the flow of oxygen into the oxygen mask, by reducing oxygen pressure to a breathable level. Regulators are designed for either high or low pressure depending on the application. Regulator features may include diluter demand for diluting the supplemental oxygen with ambient air to extend the duration of the oxygen supply or automatic positive pressure for flights above 30,000 feet. Regardless of the features, each oxygen regulator is in essence a pressure reducer. They range in size from 1 3/4 by 2 1/4 inches to 9 by 10 inches. They are designed to operate in a temperature range of -65° F to 160° F (-54° C to 71.1° C).

Continuous Flow Regulators. Continuous flow regulators are used in a limited number of naval aircraft. These regulators do not satisfactorily meet all the oxygen requirements for varying

degrees of aircrew activity. Continuous flow regulators are not authorized for use by aircrew members, but are authorized for passenger use.

Diluter Demand Type Regulators. The 2858 diluter demand oxygen regulator is panel mounted and is used with the MBU series pressure demand oxygen masks. The regulator incorporates a pressure gauge, a flow indicator, and an air valve lever. It has an operating altitude range from 0 to 37,500 feet (Figure 1-25). The diluter demand regulator provides the aircrewman with an air oxygen mixture, or 100 percent oxygen, depending upon the mode of operation selected. By placing the air valve lever in the "NORMAL" position, the oxygen is diluted with ambient air up to approximately 28,000 to 32,000 feet. The ratio of oxygen to air is automatically adjusted to supply increasing oxygen as altitude increases. At approximately 32,000 feet, ambient air is shut off and the user receives 100 percent oxygen. By selecting 100 percent oxygen, the regulator supplies 100 percent at all altitudes. The diluter demand regulator is located on T-28s and cargo planes that utilize walkaround oxygen bottles.

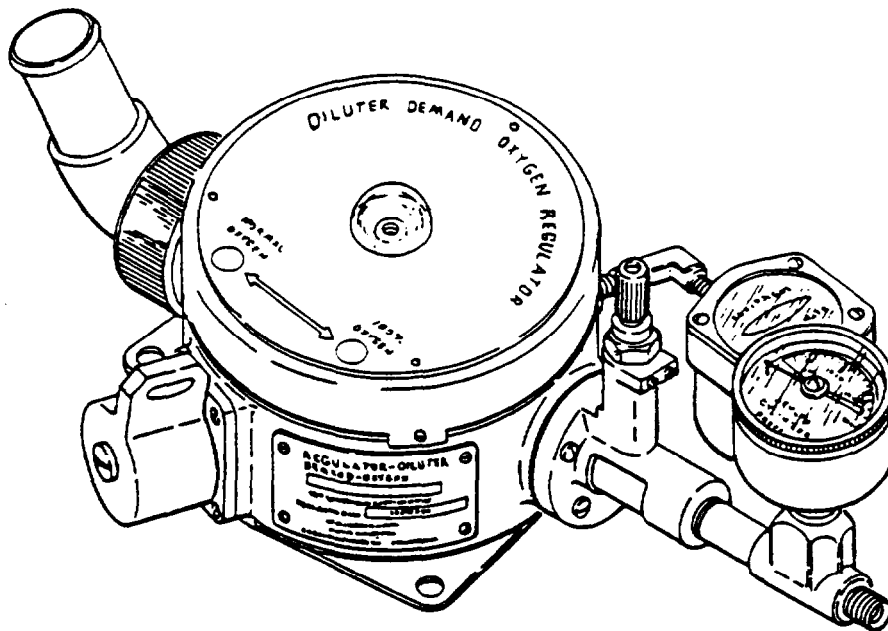

Figure 1-25. Diluter demand oxygen regulator -2858 serves.

Physiology of Flight

Automatic Positive Pressure Diluter Demand Regulators. These regulators come in two basic types, either torso or aircraft panel mounted.

1. Torso Mounted Regulators.

a. *Regulator P/N 3260002-0301.* This regulator (Figure 1-26) is used as part of the oxygen system in the AV-8 Harrier aircraft. It delivers 100 percent oxygen with safety pressure, or an air-oxygen mixture to the aircrewman depending on altitude and mode of selection. With the control knob in the "NORM" mode, an air-oxygen mixture is supplied upon demand up to approximately 20,000 feet. Between the altitudes of 20,000 and 30,000 feet, 100 percent oxygen is supplied upon demand. With the regulator in the 100 percent oxygen setting at a positive pressure (safety pressure) of 0.01 to 2.0 inches of water pressure is supplied from sea level to approximately 30,000 feet. At 30,000 feet, the regulator provides pressure breathing with the pressure increasing proportionally with altitude to a maximum pressure of 15 inches of water pressure at 50,000 feet.

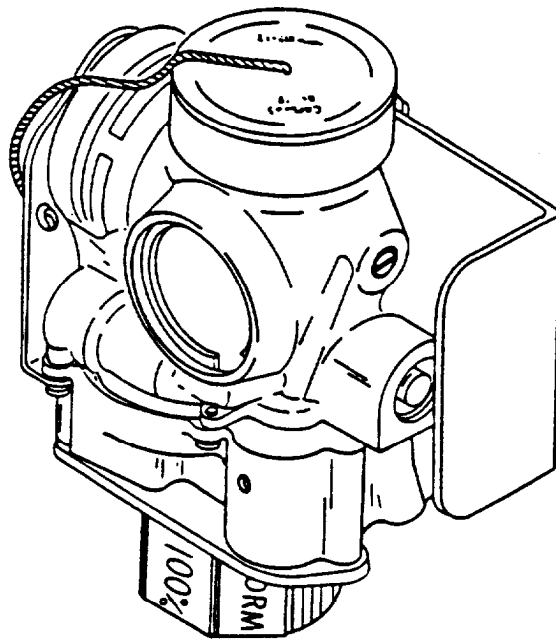

Figure 1-26. Diluter demand oxygen breathing regulator, part number 3260002-0301.

b. *Regulator P/N 900-002-051-03 and 900-002-051-04.* This regulator (Figure 1-27) is used as part of the oxygen system in all S-3 aircraft. With the regulator in the diluter mode an air-oxygen mixture is provided from sea level to between 27,000 and 29,000 feet. Between the altitudes of 27,000 and 29,000 feet the aneroid expands closing the air valve, preventing ambient air from entering the regulator and the user receives 100 percent oxygen. With the regulator in the 100 percent mode, 100 percent oxygen at a positive pressure (safety pressure) of 0 to 1.5 inches of water pressure is supplied from sea level to approximately 38,000 feet. At 38,000 feet the regulators provide pressure, with the pressure increasing proportionally with altitude to a maximum pressure of 18 inches of water pressure at 50,000 feet.

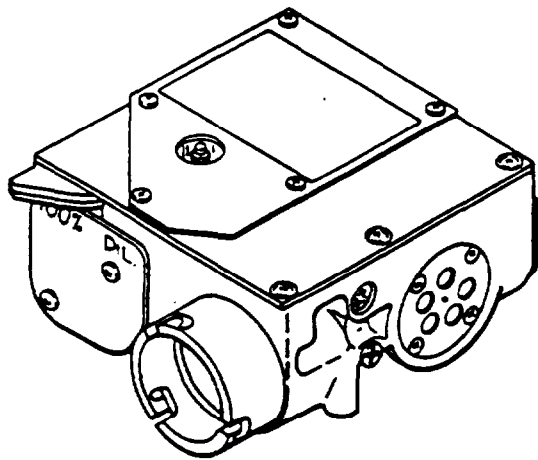

Figure 1-27. Diluter demand torso-mounted oxygen regulators, part numbers 900-002-051-03 and 900-002-051-04.

2. *Aircraft Panel Mounted Regulators.* Several types of aircraft panel-mounted regulators are installed in naval aircraft (Figures 1-28, 1-29, 1-30, 1-31). These regulators are supplied in two basic configurations: low pressure (50 to 500 psig operating range), and high pressure (50 to 2000 psig operating range). The most common panel mounted regulator in use at this time is the MD/CRU series #29255 regulator. They can be found in most nonejection seat equipped aircraft using personal oxygen equipment.

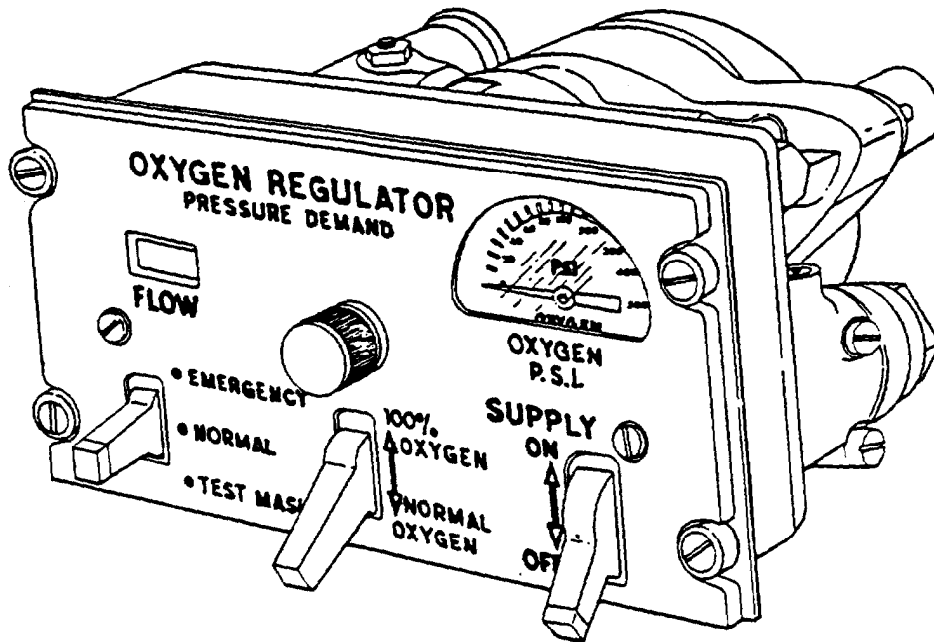

Figure 1-28. Aircraft panel mounted oxygen regulator, type MD-1, CRU-52/A, CRU-54/A, CRU-55/A, and CRU-57/A.

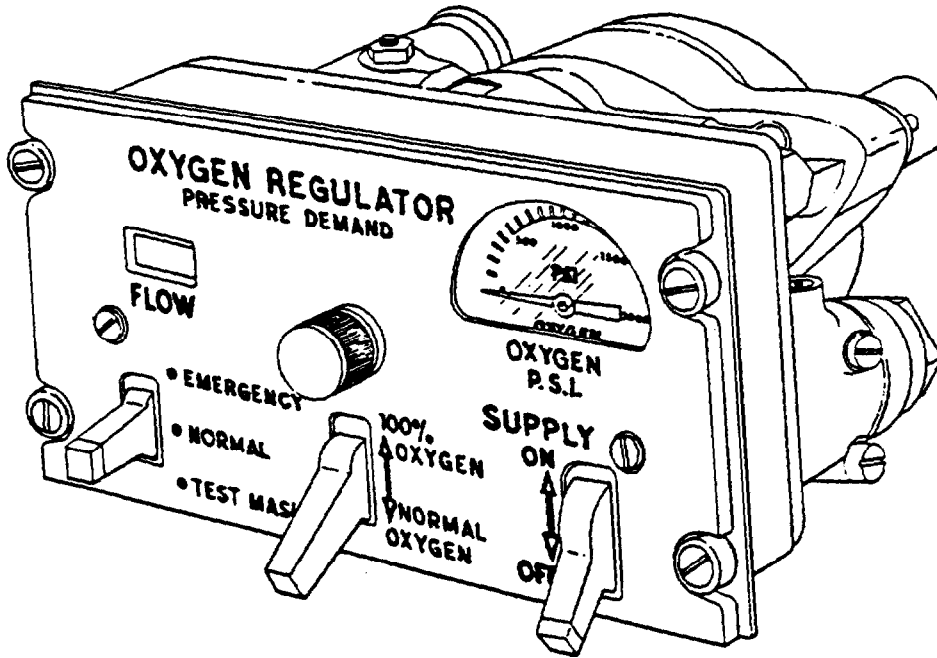

Figure 1-29. Aircraft panel mounted oxygen regulator, type MD-2 and CRU-72/A.

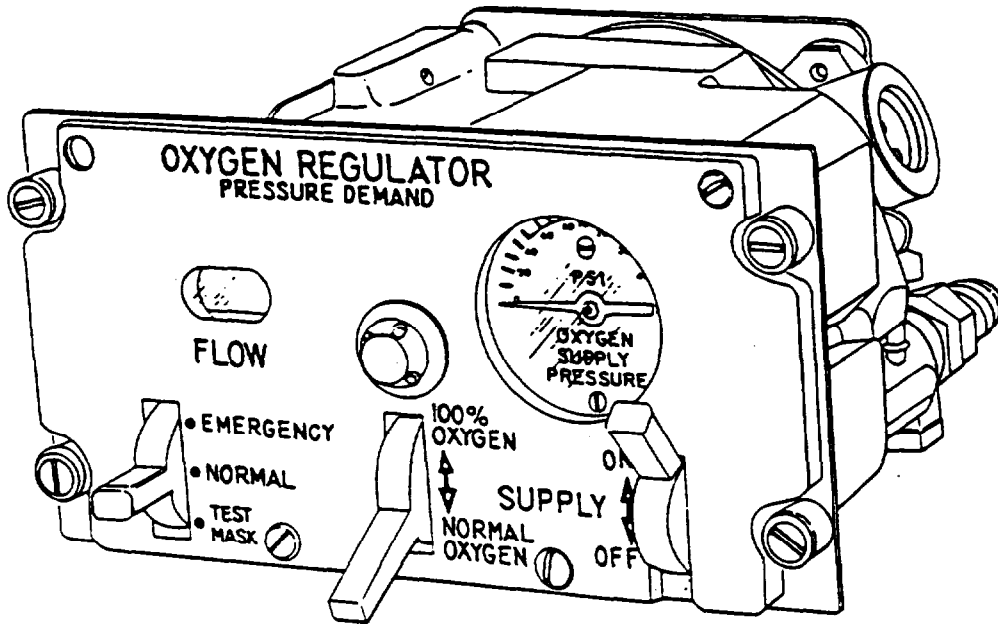

Figure 1-30. Aircraft panel mounted oxygen regulator, low pressure, part numbers 29255-10A-A1, 29255-10A-B9, 29255-10A-A2, 29255-10A-A4, 29255-10A-A5, 29255-10A-A9, and 29255-10A-A11.

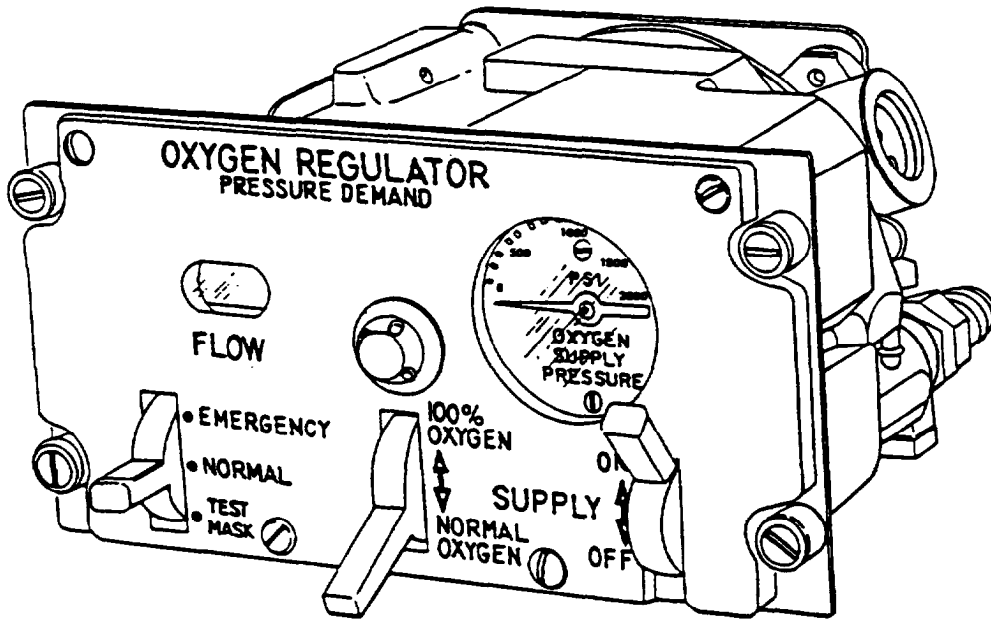

Figure 1-31. Aircraft panel mounted oxygen regulator, high pressure, part numbers 29255-6B-B1 and 29255-6B-A1.

Physiology of Flight

The following controls and indicators are located on the front panel of the regulator. The small oblong shaped window area on the left side of the panel marked FLOW, indicates the flow of oxygen through the regulator by a visible blinking action. The pressure gauge is found on the upper right of the panel and indicates inlet pressure to the regulator. The regulator has three control toggles. A supply toggle located on the lower right corner is used to control the supply of oxygen to the regulator. The dilute toggle located on the lower center of the panel has two positions: 100 percent OXYGEN and NORMAL OXYGEN. In the 100 percent OXYGEN position the regulator delivers 100 percent oxygen upon inhalation by the user. In the NORMAL OXYGEN position the regulator delivers a mixture of air and oxygen with the air content decreasing until a cabin altitude of approximately 30,000 feet is reached. Above this altitude 100 percent oxygen is delivered to the user upon inhalation.

The emergency pressure control located on the lower left of the panel has three positions: EMERGENCY, NORMAL, and TEST MASK. The EMERGENCY position delivers positive pressure to the outlet at altitudes when positive pressure is not automatically delivered. In the TEST MASK position, oxygen is delivered to the mask under pressure too high to breathe and is used to check the mask. The switch must be in the NORMAL position to assure normal system operation.

The MD/CRU series regulators are designed for use to 43,000 feet with an emergency ceiling of 50,000 feet. With the supply lever placed at the ON position, the diluter lever placed in the NORMAL oxygen position, and the emergency lever placed in the NORMAL position; the regulator will supply a mixture of oxygen and ambient air at low altitudes. The percent of oxygen will gradually and automatically increase to 100 percent at approximately 28,000 to 32,000 feet. At cabin altitudes of approximately 27,000 feet the regulator will automatically begin to deliver positive pressure. At 50,000 feet the positive pressure will be approximately 11 to 18 inches of water pressure.

Miniature Oxygen Breathing Regulators. Several types of CRU-79/P miniature oxygen breathing regulators are utilized (Figures 1-32, 1-33, 1-34, 1-35). Miniature oxygen regulators reduce and regulate supply pressure and deliver 100 percent oxygen to the user at a breathable pressure. A safety pressure feature automatically maintains a positive pressure of 0 to 2.5 inches of water pressure in the mask at altitudes up to and including 34,000 feet. The pressure breathing feature maintains a positive pressure in the mask of up to 20.0 inches of water pressure at altitudes between 35,000 and 50,000 feet. The positive pressure increases as altitudes increases. Miniature oxygen regulators can be used routinely up to approximately 43,000 feet, with an emergency ceiling of 50,000 feet for very short periods.

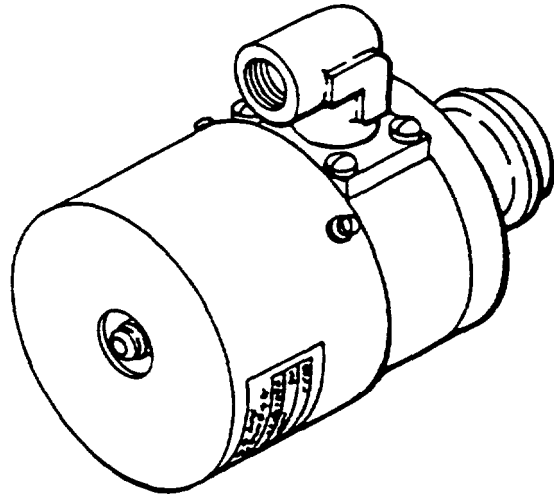

Figure 1-32. Miniature oxygen breathing regulator type CRU-79/P.

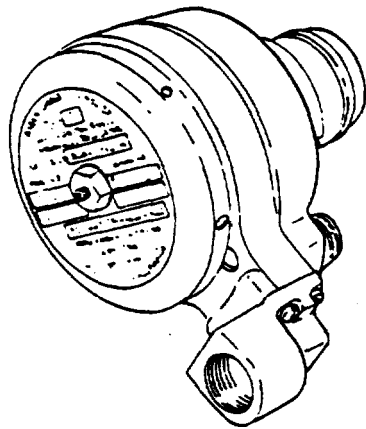

Figure 1-33. Miniature oxygen breathing regulator model 226-20004-3.

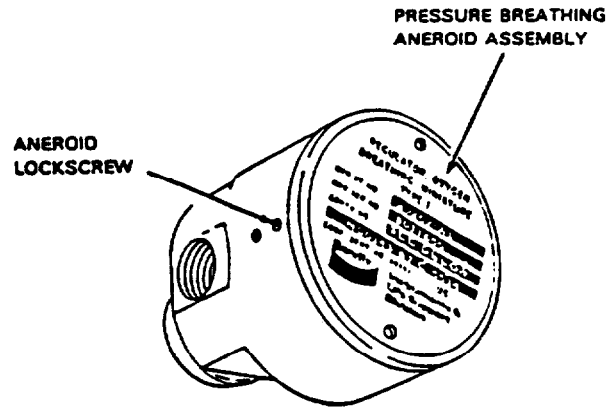

Figure 1-34. Miniature oxygen breathing regulator model 29267-A1.

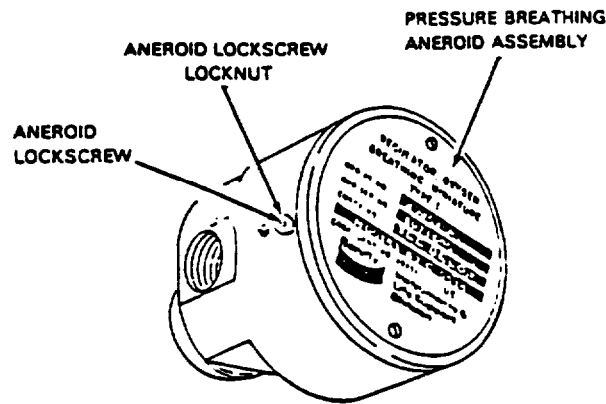

Figure 1-35. Miniature oxygen breathing regulator model 3260024-0101.

A-21 Oxygen Regulator. The A-21 type regulator which forms part of the MA-1 portable breathing device, is a demand and pressure breathing type regulator which will deliver oxygen to the user upon demand, or provide a positive pressure to the mask or the MBU-12/P oxygen mask configuration. During normal operation the selector knob is positioned in the NORM position and will deliver 100 percent oxygen upon demand. When the selector knob is placed in the 30M, 42M, or EMER position, the unit will deliver 100 percent oxygen at a positive pressure of 1.6 to 14.0 inches of water pressure, depending upon the positioning of the selector knob from sea level to the service ceiling of the aircraft.

Oxygen Masks

One of the most critical features in the oxygen supply system is the breathing mask. An oxygen mask is used for the purposes of delivering oxygen to the user's respiratory system. Oxygen masks are designed for either pressure breathing or continuous flow regulators. The features such as microphones, amplifiers, regulators, or connectors will be determined by the application. All masks include some kind of face seal and an arrangement of valves to direct the flow of inhaled and exhaled gases. The mask provides facial protection from fire and projectiles.

Pressure-Demand Oxygen Mask Assemblies. The pressure-demand oxygen mask is used by aircrew members who wear fixed wing helmet assemblies and use oxygen routinely. The pressure-demand oxygen mask is based on the MBU-12/P (Figure 1-36) oxygen mask subassembly. The MBU-12/P subassembly features an integral hardshell (polysulphmate) facepiece (silicone), flexible silicone hose, and combination inhalation and exhalation valve. Components must be added to or removed from the basic MBU-12/P subassembly to obtain the desired oxygen mask configuration (Figures 1-37 thru 143). The versatility of the pressure demand oxygen mask allows it to be worn with chest mounted regulators in tactical jets as well as panel mounted regulators and walkaround bottles. A properly fitted oxygen mask is essential to helmet retention in high speed ejections.

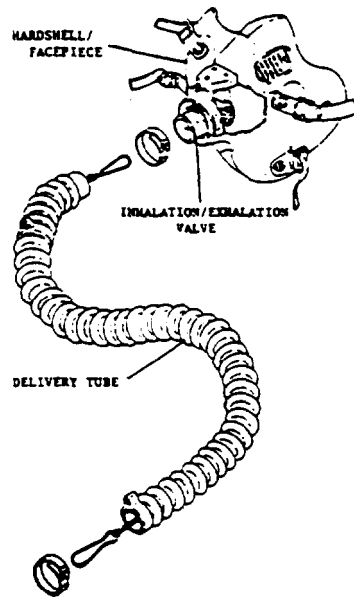

Figure 1-36. MBU-12/P oxygen mask assembly.

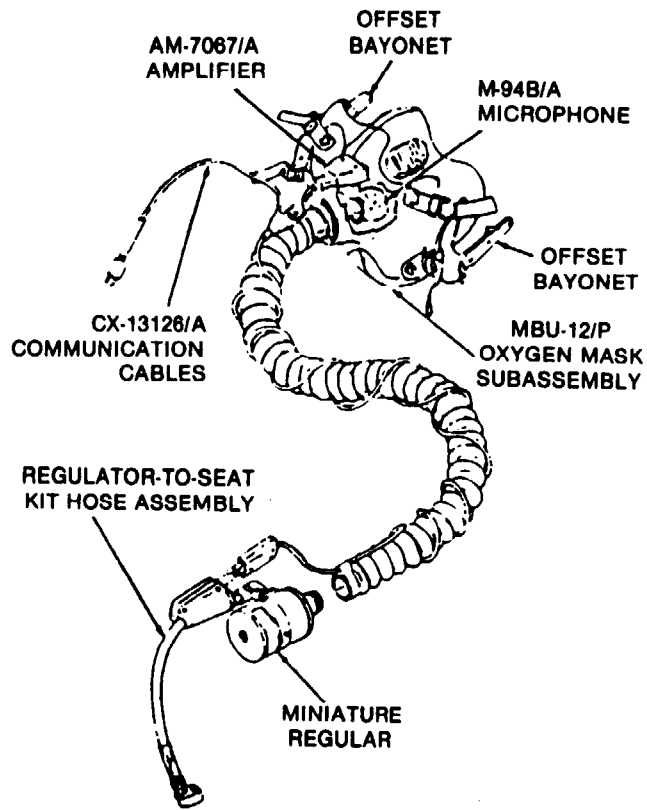

Figure 1-37. MBU-14 (V) 1/P oxygen mask assembly.

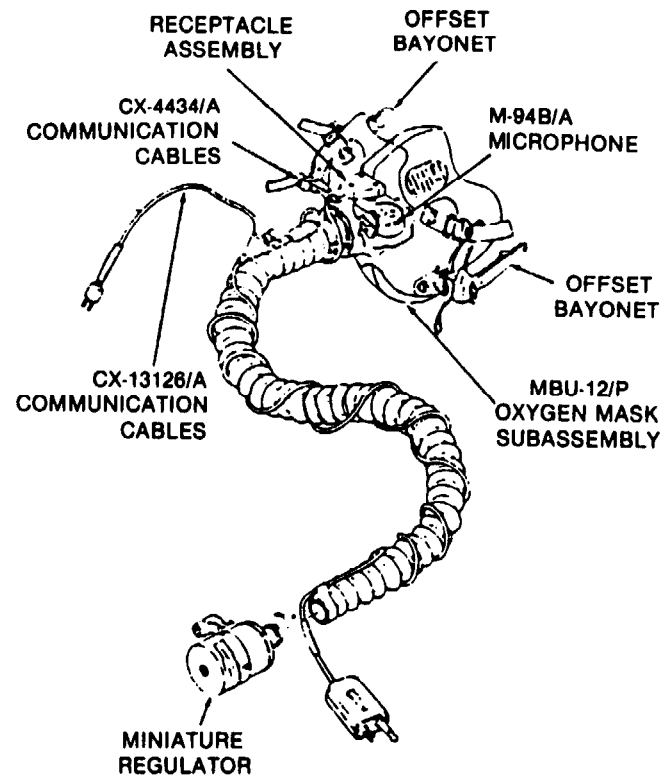

Figure 1-38. MBU-14 (V) 2/P oxygen mask assembly.

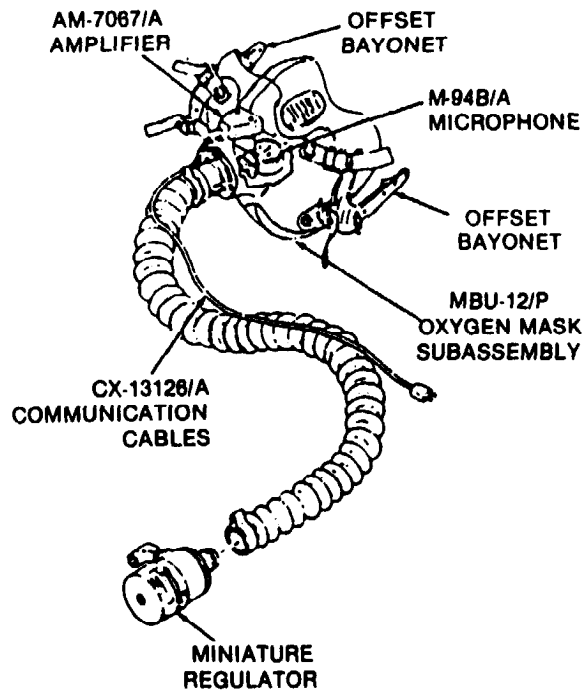

Figure 1-39. MBU-14 (V) 3/P oxygen mask assembly.

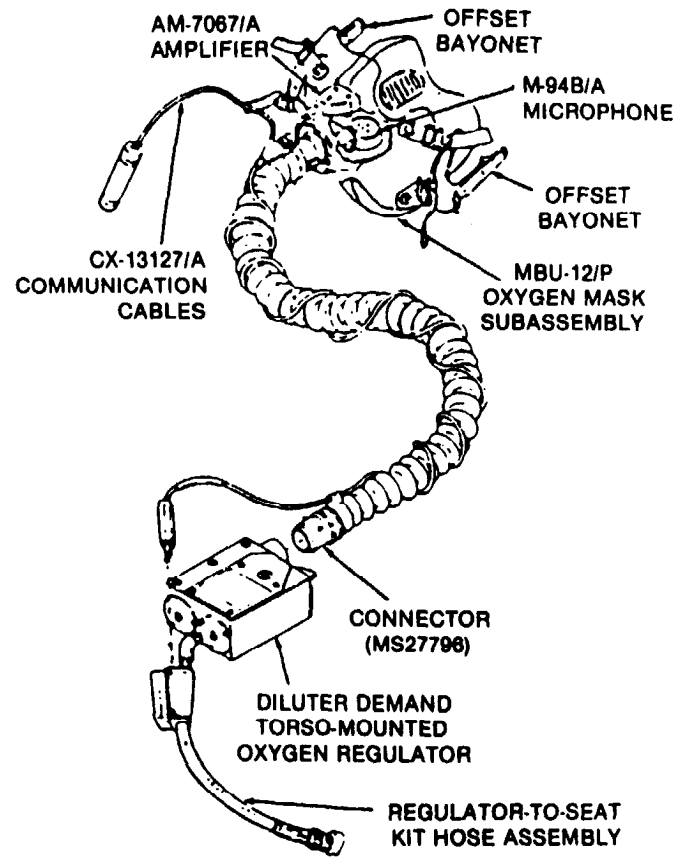

Figure 1-40. MBU-15/P oxygen mask assembly.

1-95

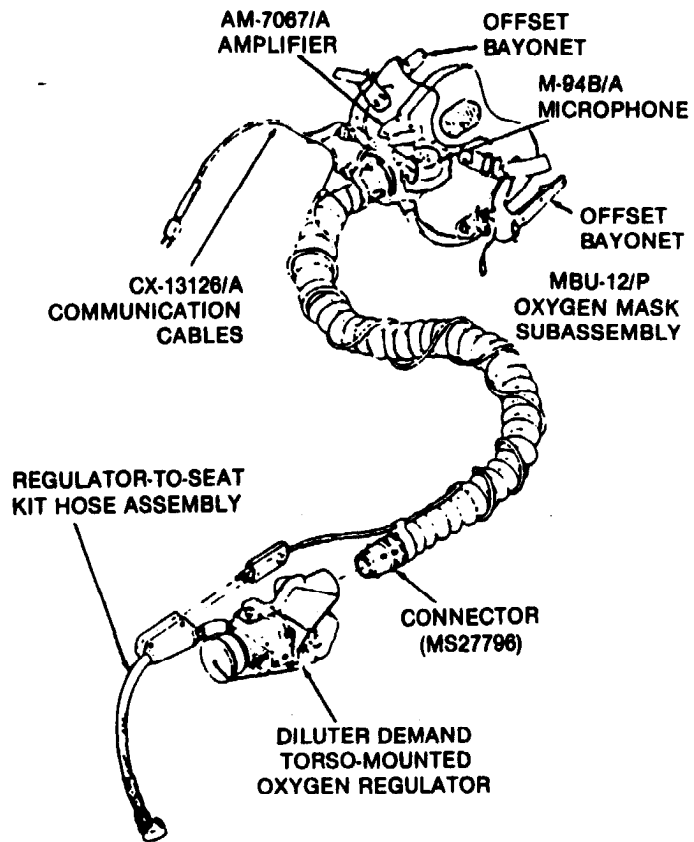

Figure 1-41. MBU-16/P oxygen mask assembly.

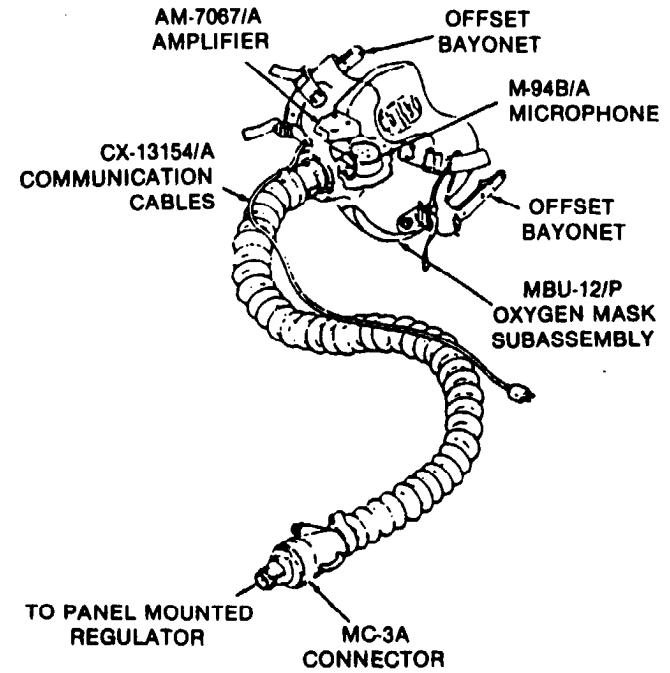

Figure 1-42. MBU-17 (V) 1/P oxygen mask assembly.

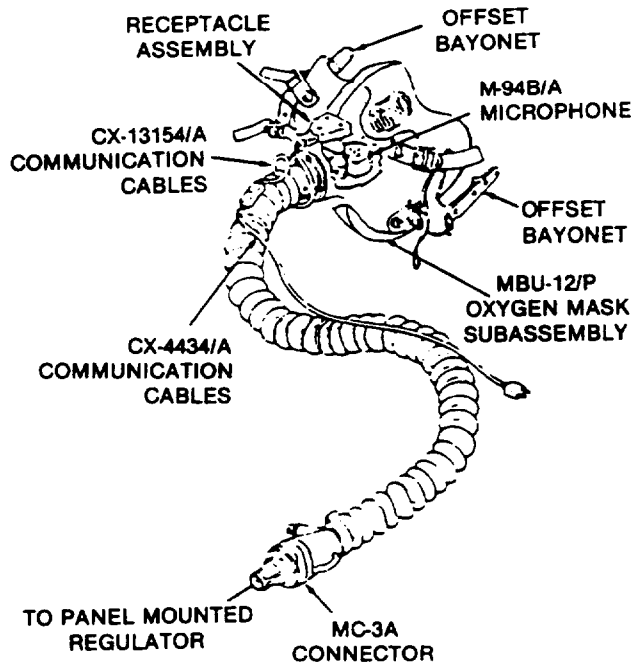

Figure 1-43. MBU-17 (V) 2/P oxygen mask assembly.

Quick-Don Oxygen Mask. The MBU-10/P Oxygen Mask Assembly (Figures 1-44, 1-45) consists of a hanging suspension holder, a suspension assembly, an oxygen mask assembly, a cable and plug assembly, and a dust cover. The MBU-12/P oxygen mask subassembly is used and is supplied in one size - regular. The Quick-Donning MBU-10/P oxygen mask assembly permits the aircrew to breathe gaseous oxygen. The oxygen supply enters the facepiece through the valve located at the bottom of the mask. Inhaled air passes out through the same valve. The exhalation portion of the valve is constructed so that a pressure of only one millimeter of mercury greater than the inlet pressure being supplied by the regulator will force open the valve and allow exhaled air to flow from the mask. The mask also provides automatic electrical switching from the headset microphone to the oxygen mask microphone. This feature permits the aircrewmembers while wearing the mask to transmit the same as with the headset microphone, without the need to unplug the headset microphone and then plug in the oxygen mask microphone. Currently the MBU-10/P oxygen mask is used on selected C-130 Aircraft.

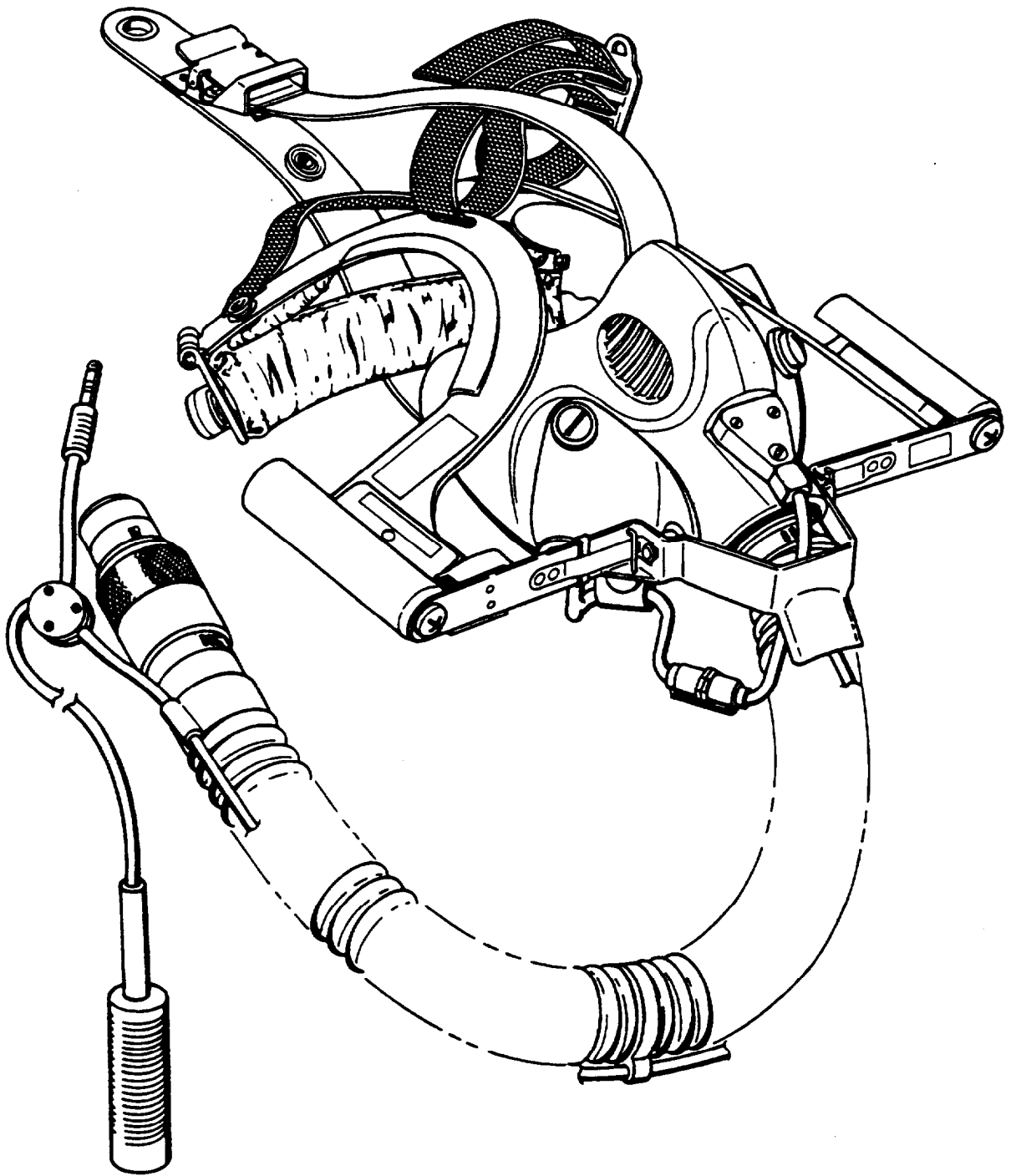
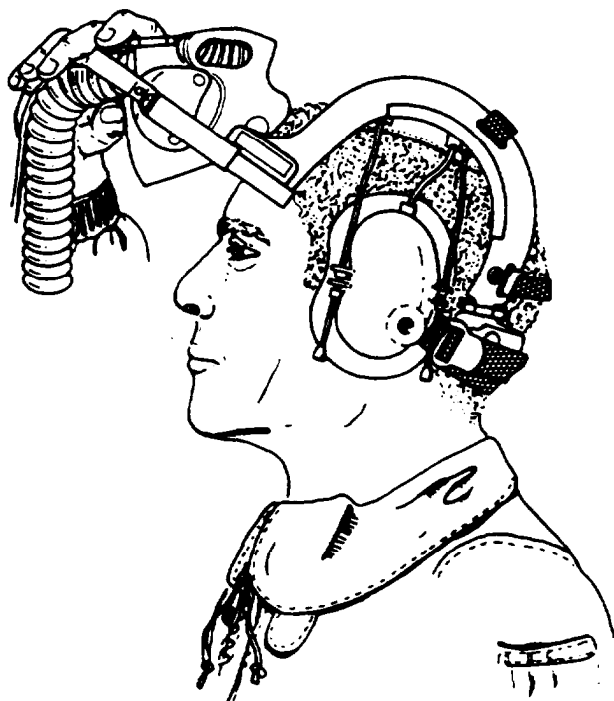

Figure 1-44. MBU-10/P oxygen mask.



Step 1. Starting Position

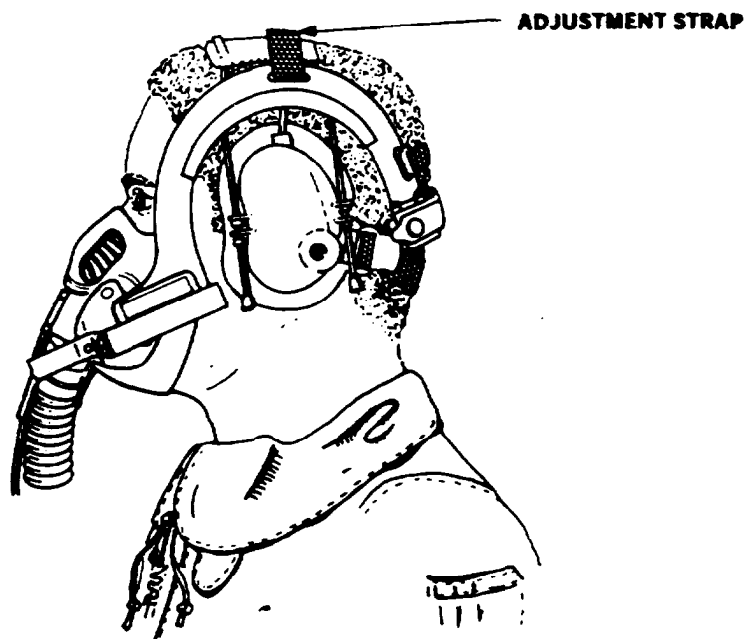

Figure 1-45. Donning procedure.

Sierra Quick-Don Oxygen Mask. The Sierra Quick-Don oxygen mask (Figure 1-46) is designed to provide the proper dilution of oxygen with cabin air to conserve oxygen at lower altitudes. The Sierra Quick-Don mask consists of a spring loaded head harness, face piece, microphone, and oxygen supply hose. The mask has two oxygen settings, NORMAL and 100 percent OXYGEN. The selector switch is located on the left side of the regulator attached to the mask. A white button located on the front of the regulator allows the crew member to receive additional oxygen under pressure. The Sierra Quick-Don Mask is carried on some C-9, C-12, CT-39 and T-44 aircraft.

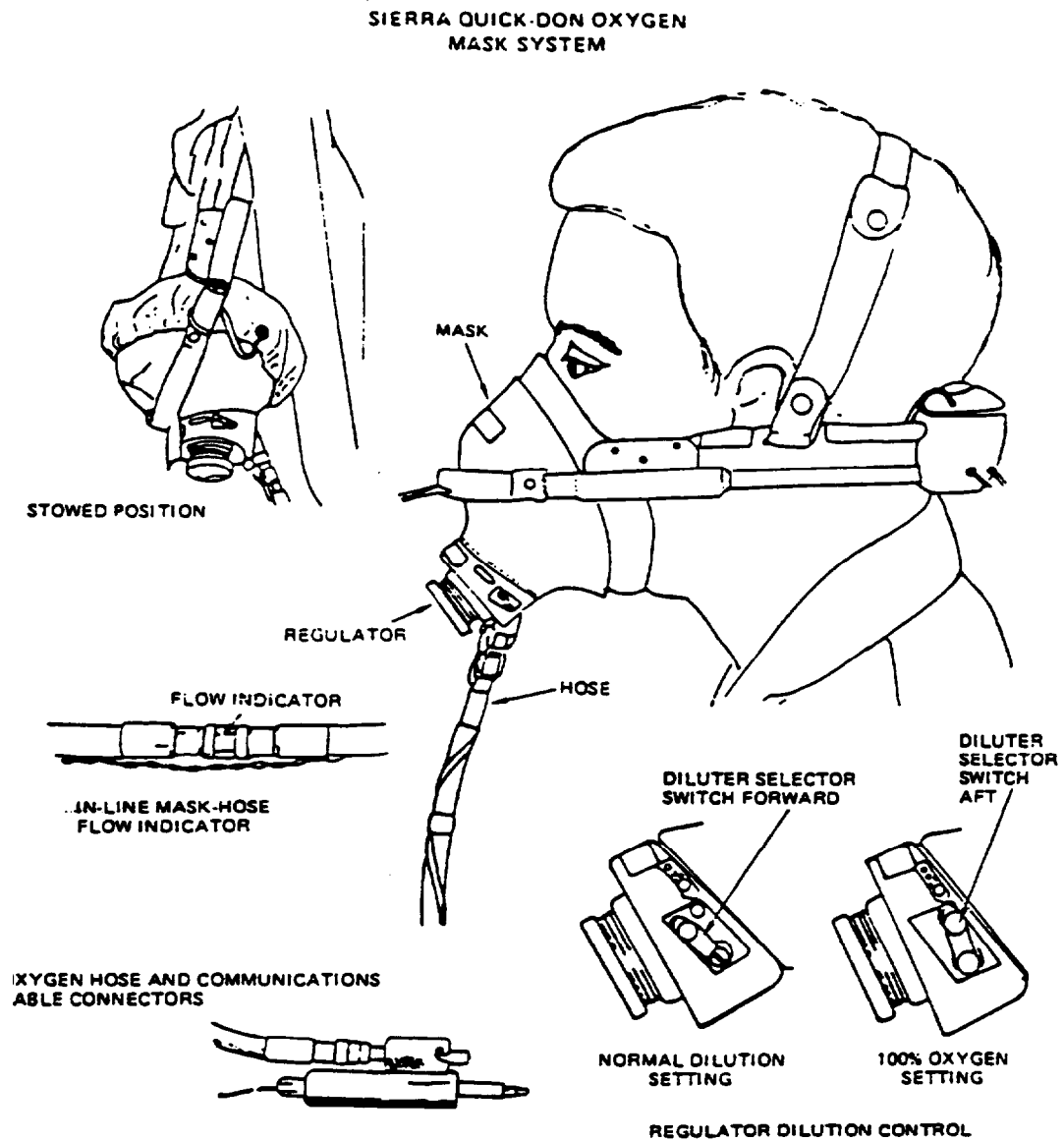

Figure 1-46. Sierra quick-don oxygen mask system.

Full Face Oxygen and Smoke Mask. The full face oxygen and smoke mask (Figure 1-47) is designed to dispense gaseous oxygen from a demand type regulator to the user. The smoke mask provides oxygen and face protection to aircrew members who use oxygen equipment only in rare or emergency situations. The mask also provides protection from smoke, carbon monoxide, or other incapacitating gases. The full face oxygen and smoke mask has a single configuration of the facepiece, delivery hose, and MC-3A connector. The mask consists of a molded rubber face piece with microphone cavity. It has five fitting straps, an acrylic plastic lens, and exhalation valve. The delivery hose (K-4 hard hose) is composed of nonstretch, nonkinking, smooth bore, flexible hose with an integral corrosion resistant wire. The hose cover is knitted or braided of tubular polyamide or polyester. The communication cable is molded into the hose with leads extending for attachment for a mask mounted microphone. It also has a connection for attaching to the aircraft communications system. The MC-3A connector is provided for access to the aircraft oxygen system. The full face oxygen and smoke mask is carried on P-3 and C-130 aircraft.

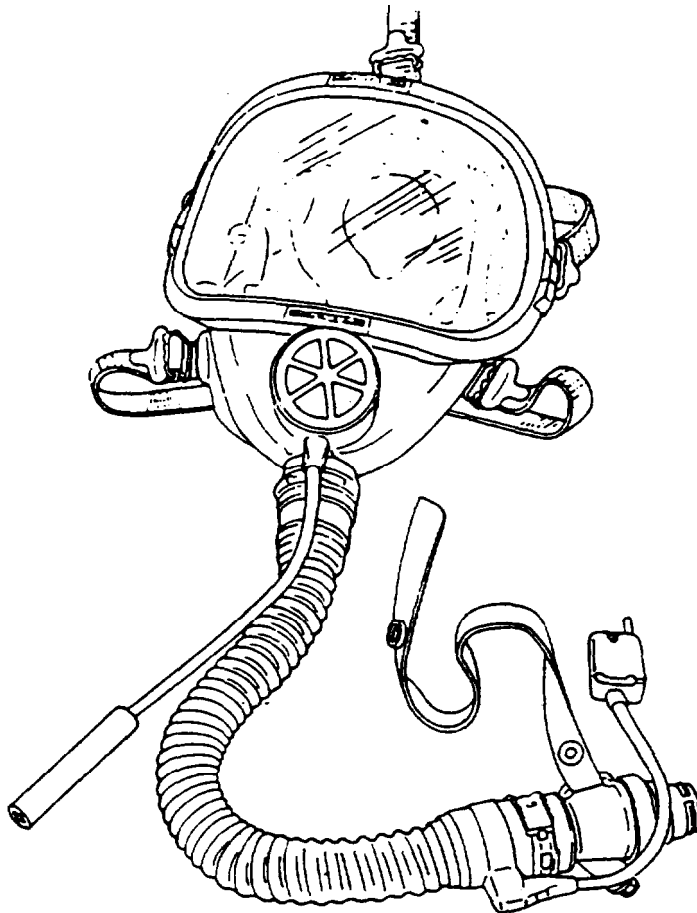

Figure 1-47. Full face oxygen and smoke mask.

Physiology of Flight

References and Bibliography

- Agostini, A., Stabilini, R. Bemasconi, C., & Gerdi, G.C. The Hb-O₂ dissociation curve in hypercapnic patients. *American Heart Journal*, 1974, 87, 670-672.
- Arthur, D., Margulies R. The pathophysiology, presentation and triage of altitude-related decompression sickness associated with hypobaric chamber operation. *Aviation, Space and Environment Medicine*, 1982, 53, 489-494.
- Balldin, U.I., & Borgstrom, P. Intracardial bubbles during decompression to altitude in relation to decompression sickness in man. *Aviation, Space & Environmental Medicine*, 1976, 47, 113-116.
- Bason, R., Pheeny, H., & Dully, F.E., Jr. Incidence of decompression sickness in Navy low pressure chambers. *Aviation, Space and Environmental Medicine*, 1976, 47, 995-997.
- Billings, C.E. Atmosphere. In J.F. Parker, Jr. & V.R. West (Eds.), *Bioastronautics data book* (2nd ed.) (NASA SP-3006). Washington, DC: U. S. Government Printing Office, 1973a.
- Billings, C.E., Barometric Pressure. In J.F. Parker, Jr. & V.R. West (Eds.), *Bioastronautics data book* (2nd ed.) (NASA SP-3006). Washington, DC: U.S. Government Printing Office, 1973b.
- Billings, C.E., & Roth, E.M. Pressure. In P. Webb (Ed.), *Bioastronautics data book* (NASA SP-3006). Washington, DC: U.S. Government Printing Office, 1964.
- Behnke, A.R. Decompression sickness: Advances and Interpretations. *Aerospace Medicine*, 1971, 42, 255-267.
- Berry, CA., & Hekhuis, G.L. X-ray survey for bone changes in low pressure chamber operators. *Aerospace Medicine*, 1960, 31, 760-766.
- Blockley, W.V., & Hanifan, D.T. *An analysts of the oxygen protection problem at flight altitudes between 40,000 and 50,000 feet*. Santa Monica, California: Webb Associates, 1961.
- Boothby, W.M., Lovelace, W.R. II, Benson, O.O. Jr., & Strehler, A.F. Volume and partial pressures of respiratory gases at altitude. In W.M. Boothby (Ed.), *Handbook of respiratory physiology*. Randolph AFB, Texas: Air University, USAF School of Aviation Medicine, September 1954.
- Bornmann, R.C. Limitations in the treatment of diving and aviation bends by increased ambient pressure. *Aerospace Medicine*. 1968, 39, 1070-1076.
- Boyle, J., III. Theoretical tram-respiratory pressure during rapid decompression: I. Model experiments and II. Animal experiments. *Aerospace Medicine*. 1973, 44, 153-162.
- Buckles, R.G. The physics of bubble formation and growth. *Aerospace Medicine*, 1968, 39, 1062-1068.
- Brown, H.H.S. The pressure cabin. In J.A. Gillies (Ed.), *A textbook of aviation physiology*. New York: Pergamon Press, 1965.
- Bryan, A.C. Breathing. In P. Webb (Ed.), *Bioastronautics data book* (NASA Sp-3006). Washington, DC: U.S. Government Printing Office, 1964.
- Campan, C. F., et al (Eds.) *Handbook of geophysics* (rev. ed.). New York: Macmillan, 1960.
- Carlson, L.D. Gas exchange and transportation. In T.C. Ruch & J.F. Fulton (Eds.), *Medical physiology and geophysics* (18th ed.). Philadelphia: W.B.Saunders, 1965a.
- Carlson, L.D. Gas exchange and transportation. In T.C. Ruch & J.F. Fulton (Eds.), *Physiology and biophysics* (19th ed.). Philadelphia: W.B. Saunders, 1965b.
- Carlyle, L. High altitude breathing. *Approach* January 1963, Pp. 30-35.
- Catron, P., Hallenbeck, J., Flynn, E., Bradley, M., & Evans, D. *Pathogenesis and treatment of cerebral air embolism and associated disorders*. Bethesda, MD: Naval Research Institute, April 1984.

U.S. Naval Flight Surgeon's Manual

- Clamann, H.G. Decompression sickness. In H.G. Armstrong (Ed.), *Aerospace medicine*. Baltimore: The Williams & Wilkins, 1961.
- Clark, J.M., & Lambertsen, C.J. Pulmonary oxygen toxicity: A Review. *Pharmacological Review*, 1971, 23, 37-133.
- Comroe, J.H., Jr., *Physiology of respiration*. Chicago: Yearbook Medical Publishers, 1965.
- Cooke, J.P. Denitrogenation interruptions with air. *Aviation, Space and Environmental Medicine*, 1976, 47, 1205-1209.
- Davis, J.C. *Hyperbaric oxygen theory*. Bethesda, MD: Undersea Medical Society, 1977.
- Department of the Navy, Bureau of Medicine and Surgery. Policy for clinical use of recompression chambers for nondiving illnesses (BUMEDINST 6320.38A).
- Department of the Navy, Office of the Chief of Naval Operations. General flight and operating instructions (OPNAVINST 3710.7 series).
- DeHart, R. L., (Ed.), *Fundamentals of aerospace medicine*, Philadelphia: Lea & Febiger, 1985.
- Department of the Navy, Office of the Chief of Naval Operations. *General flight and operating instructions*(OPNAVINST 3710.7 series).
- Dhenin, G. (Ed.), *Aviation medicine, physiology and human factors*. London: Tri-Med Books, 1978.
- Donnell, A.M., & Norton, C.P. Successful use of the recompression chamber in severe decompression sickness with neurocirculatory collapse. *Aerospace Medicine*, 1960, 31, 1004-1009.
- Downey, V.M., Tracy, W.W., Hockworth, R., & Whitley, J. L. Studies on bubbles in human serum under increased and decreased atmospheric pressures. *Aerospace Medicine*, 1963, 34, 116-118.
- Duvelleray, M.A., Mehmel, H.C., & Laver, M. Hb-O₂ equilibrium and coronary blood flow: A model. *Journal of Applied Physiology*, 1973, 35, 480-435.
- Edmonds, C., & Pennefather, J. Diving and subaquatic medicine. Australia: Diving Medical Center, 1981.
- Ernsting, J. The physiological requirements of aircraft oxygen systems. In J.A. Gillies (Ed.), *A textbook of aviation physiology*. New York: Pergamon Press, 1965.
- Ernsting, J. The physiology of pressure breathing. In J.A. Gillies (Ed.), *A textbook of aviation physiology*. New York: Pergamon Press, 1965a.
- Ernsting, J. Respiration and anoxia. In J.A. Gillies (Ed.), *A textbook of aviation physiology*. New York: Pergamon Press, 1965b.
- Ernsting, J. *Some effects of raised intrapulmonary pressure in man* (AGARDograph 106). Maidenhead, England: Technivision, 1966.
- Ernsting, J., & King P. *Aviation Medicine*. Boston: Butterworths, 1988.
- Ernsting, J. The use of the pressure economiser oxygen system in high performance aircraft in which crew members are routinely exposed to positive acceleration (FPRC Memo 215). Famborough, England: RAF Institute of Aviation Medicine, September 1964.
- Evans, A., Bainard, E.E.P., & Walder, D.N. Detection of gas bubbles in man at decompression. *Aerospace Medicine*, 1972, 43, 1095-1096.
- Evans, W.O., Robinson, S.M., Horstman, D.H. Jackson, R.E., & Weiskopf, R.E., & Weiskopf, R.B. Amelioration of the symptoms of acute mountain sickness by staging and acetazolamide. *Aviation, Space and Environmental Medicine*, 1976, 47, 512-516.
- Fellenius, E., & Samuelson, R. Effects of severe systemic hypoxia on myocardial energy metabolism. *Journal of Scandanavian Physiology*, 1973, 88, 256-266.

Physiology of Flight

- Flynn, E., Bayne, C.G., & Catron, P.W. *Diving Medical Officer's student guide*, Millington: Naval Technical Training Command, 1980.
- Folbergrova, J., & Siesjo, K. Regulatory mechanism affecting carbohydrate substrates in the brain in hypercapnic acidosis. *Journal of Scandanavian Physiology*, 1973, 88, 281-284.
- Fryer, D.I. Evolution of concepts in the etiology of bends. *Aerospace Medicine*, 1968, 39, 1058-1061.
- Fryer, D. I. *Subatmospheric decompression sickness* (AGARDograph 125). Slough, England: Technivision, 1969.
- Fryer, D. I. & Roxburgh, H.L. Decompression sickness. In J.A. Gillies (Ed.), *A textbook of aviation physiology*. New York: Pergamon Press, 1965.
- Fulton, J.F. (Ed.). *Decompression sickness*. Philadelphia: W.B. Saunders, 1951.
- Furry, D.E. Incidence and severity of altitude decompression sickness in Navy hospital corpsmen. *Aerospace Medicine*, 1973, 44, 450-452.
- Furry, D.E., Reeves, E., & Beckman, E. Relationship of SCUBA diving to the development of aviator's decompression sickness. *Aerospace Medicine*. 1967, 38, 825-828.
- Gillies, J.A. (Ed.), *A textbook of aviation physiology*. New York: Pergamon Press, 1965 (or latest edition).
- Goodman, M.W. Decompression sickness treated with compression to 2-6 atmospheres absolute. *Aerospace Medicine*, 1964, 35, 1204-1212.
- Greenwald, A.J., Allen, T.H. & Bancroft, R.W. Abdominal gas volume at altitude and at ground level (SAM TR-67-102). Brooks Air Force Base, Texas: USAF School of Aviation Medicine, 1967.
- Guyton, A. C. *Textbook of Medical Physiology* (7th ed.). Philadelphia: W.B. Saunders, 1986.
- Hills, B.A. *Decompression sickness, Volume 1: The biophysical basis of prevention and treatment*. New York: John Wiley and Sons, 1977.
- Hodgson, C.J., Davis, J.C., Randolph, C.L., & Chambers, G.H. Seven year follow-up x-ray survey for bone changes in low pressure chamber operators. *Aerospace Medicine*, 1968, 39, 417-422.
- Hohnstrom, F.M., & Beyer, D.H. Decompression sickness and its medical management. *Military Medicine*, 1965, 130, 872-877.
- Hultgren, N.H., & Grover, R.F. Circulatory adaption to high altitude. *Annual Review of Medicine*, 1968, 19, 119-151.
- Hurtado, A. Animals in high altitude: Resident man. In D.B. Dill, E.F. Adolph, & C.G. Wilbur (Eds.), *Handbook of physiology. Section 4: Adaptation to the environment*. Baltimore: Waverly Press, 1964.
- Johannsson, H., & Siesjo, K. Blood flow and oxygen consumption in the rat brain in dilutional anemia. *Journal of Scandanavian Physiology*, 1974, 91, 136-138.
- King, A.B., & Robinson, S.M. Vascular headache of acute mountain sickness. *Aerospace Medicine*, 1972, 43, 849-851.
- Lambertsen, C.J. Concepts for advances in the therapy of bends in undersea and aerospace activity. *Aerospace Medicine*, 1968, 39, 1086-1093.
- Lambertsen, C.J. *Respiration*. In Mountcastle, V.B. (Ed.), *Medical physiology* (Vol. 2. 14th ed.) St. Louis: C. V. Mosby, 1980.
- Lenfant, C., & Sullivan, K. Adaptation to high altitude. *New England Journal of Medicine*, 1971, 284, 1298-1308.
- Luft, U.C., & Finkelstein, S. Hypoxia: A clinical-physiological approach. *Aerospace Medicine*, 1986, 39, 105-109.

U.S. Naval Flight Surgeon's Manual

- Luft, U.C., Altitude sickness. In H.G. Armstrong (Ed.), *Aerospace Medicine*. Baltimore: The Williams & Wilkins, 1961.
- Luft, U.C. Aviation physiology - The effects of altitude. In Fenn W.O., & Rahn, H., (Eds.), *Handbook of physiology. Section 3, Vol. II., Respiration*. Washington, DC: American Physiological Society, 1965.
- Maher, J.T., Cymerman, A., Reeves, J.T. Cruz, J.C. Denniston, J.C. & Grover, R.F. Acute mountain sickness: Increased severity in eucapnic hypoxia. *Aviation, Space and Environmental Medicine*. 1975, 46, 826-829.
- Malette, W.G., Fitzgerald, J.B., & Cockett, A.R. Dysbarism: A review of 35 cases with suggestions for therapy. *Aerospace Medicine*, 1962, 33, 1132-1139.
- Manatt, S.A., Onboard oxygen generation systems. *Aviation, Space and Environment Medicine*, 1981, 52, 645-653.
- McFarland, R.H. *Human factors in air transportation*. New York: McGraw-Hill 1953.
- Melver, R.G. Management of bends arising during space flight. *Aerospace Medicine*, 1968, 39, 1084-1086.
- Mehmel, H.C., Duvelleray, M.A., & Laver, M. Response of coronary blood flow to pH-induced changes in Hb-O₂ affinity. *Journal of Applied Physiology*, 1973, 35, 485-489.
- Meijne, N.G. Decompression sickness and the cardiovascular system. In D.E. Busby, (Ed.), *Recent advances in aerospace medicine. Proceeding of the 18th International Congress of Aviation and Space Medicine*, Amsterdam, 1969. Dordrecht, Holland: D. Reidel Publishing, 1970, Pp. 188-197.
- Naval Sea Systems. *U.S. Navy Diving Manual* (Vol. 1, NAVSHIPS 0994-LP-001-9010). Washington, DC: U.S. Government Printing Office, 1985.
- Petty, C.A., & Bogeant, T.B. Effects of morphine, meperidine, fentanyl, and naloxone on Hb-O₂ dissociation curve. *Journal of Pharmacology and Experimental Therapeutics*, 1974, 190, 176-179.
- Phillip, R.B., Inwood, M.J., & Warren, B.A. Interactions between gas bubbles and components of the blood: Implications in decompression sickness. *Aerospace Medicine*, 1972, 43, 946-953.
- Pittinger, C.B. *Hyperbaric oxygenation*. Springfield, IL: Charles C. Thomas, 1966.
- Randel, H.W. (Ed.) *Aerospace Medicine*. Baltimore: The Williams & Wilkins, 1971.
- Rayman, R.B., McNaughton G.B. *Decompression sickness: USAF experience 1970-1980*. *Aviation, Space and Environment Medicine*, 1983, 54, 258-260.
- Roughton, F. J., & Severinghaus. J. W. An accurate determination of O₂ dissociation curve of blood above 98.7% saturation with data on O₂ solubility in blood from 0°C -37°C. *Journal of Applied Physiology*, 1973, 35, 861-868.
- Samuelsson, R. Effects of severe systemic hypoxia on myocardial excitation. *Journal of Scandinavian Physiology*, 1973, 88, 267-280.
- Scott, V. Anemia and airline flight duties. *Aviation, Space and Environmental Medicine*, 1975, 46, 830-835.
- Topliff, E.D.L. Mechanism of lung damage in explosive decompression. *Aviation, Space and Environmental Medicine*, 1976 47, 517-522.
- Van Liere, E.J., & Stickney, J.C. *Hypoxia*. Chicago: University of Chicago Press, 1963.
- Velasquez, T. Tolerance to acute anoxia in high altitude natives. *Journal of Applied Physiology*, 1959, 14, 357-362.
- Wennmaim, A., & Junstad, M. Hypoxia caused prostaglandin release from perfused rabbit hearts. *Journal of Scandinavian Physiology*, 1974, 91, 133-136.

Physiology of Flight

- West, J.B. Hypoxic man: Lessons from extreme altitude. *Aviation, Space and Environment Medicine*, 1984, 55, 1058-1062.
- Wirjosemito, S.A., Touhey, J.E., & Workman, W.T. Type II Altitude Decompression Sickness (DCS): U.S. Air Force experience with 133 cases. *Aviation, Space and Environmental Medicine*, 1989, 60, 256-261.
- Wood, J.D. Oxygen toxicity in neuronal elements. In C.J. Lambertsen (Ed.), *Underwater physiology*. New York: Academic Press, 1971.
- Wood, J.D., Peesker, S.J., & Rozdilsky, R. Sensitivity of GABA synthesis in human brain to oxygen poisoning. *Aviation, Space and Environmental Medicine*, 1975, 46, 1155-1156.
- Workman, R.D. Treatment of bends with oxygen at high pressure. *Aerospace Medicine*, 1963, 39, 1076-1083.
- United States Standard Atmosphere*, 1976, Washington, DC: Government Printing Office, 1976.

CHAPTER 2

ACCELERATION AND VIBRATION

Introduction
Sustained Acceleration
Impact Acceleration
Vibration
References

Introduction

Naval aviators are subjected to a constantly changing acceleration environment, which can profoundly affect their mission performance capability. Acceleration is defined as a time rate of change in velocity magnitude and/or direction. To describe an acceleration, both the magnitude and direction must be specified. Acceleration magnitude is expressed as velocity per unit time. For example, if velocity is expressed in meters/second (m/s), then acceleration would be expressed as m/s/s or m/s^2 . The unit of acceleration commonly used in aerospace medicine is “G” defined by the equation $G = a/g$, where a is the acceleration of interest, and g is the acceleration of gravity at the Earth’s surface ($9.8 m/s^2$ or $32.2 ft/s^2$). Thus, an aviator experiencing an acceleration of $64.4 ft/s^2$ would be experiencing $64.4/32.2$ or 2 G.

Standard terminology for acceleration direction was developed by an international conference in the early 1960s (Gell, 1961) and is expressed in terms of three axes (X,Y,Z) through the human body. A positive sign indicates the direction of the *resultant* of the acceleration rather than the direction of the acceleration itself (see Table 2-1). The vernacular section of Table 2-1 provides an easy way to visualize the resultant direction. For example, $+G_z$ is “eyeballs down” (i.e., the resultant of an upward acceleration pushes the body downward in the seat and rotates the eyeballs downward).

This chapter addresses three aspects of acceleration: sustained acceleration, transitory or impact acceleration, and vibration.

Table 2-1
Body Acceleration – Comparative Table of Equivalents

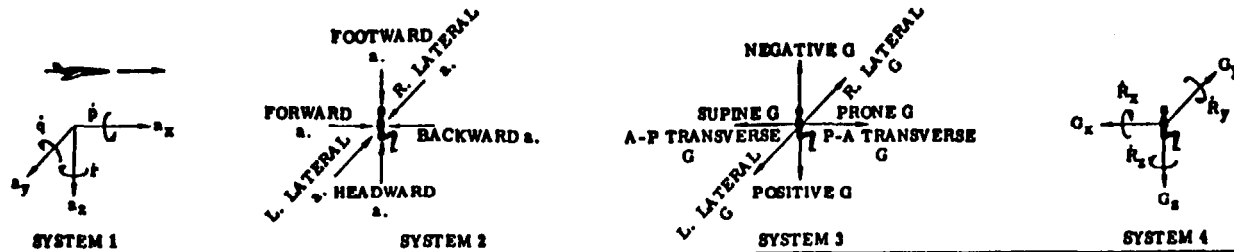

LINEAR MOTION	TABLE A Direction of Acceleration		TABLE B Inertial Resultant of Body Acceleration		
	Aircraft Computer Standard (Sys. 1)	Acceleration Descriptive (Sys. 2)	Physiological Descriptive (Sys. 3)	Physiological Computer Standard (Sys. 4)	Vernacular Descriptive
Forward	$+a_x$	Forward accel.	(1,2) Transverse A-P G Supine G Chest to Back G	$+G_x$	Eye Balls In
Backward	$-a_x$	Backward accel.	Transverse P-A G Prone G Back to Chest G	$-G_x$	Eye Balls Out
Upward	$-a_z$	Headward accel.	Positive G	$+G_z$	Eye Balls Down
Downward	$+a_z$	Footward accel.	Negative G	$-G_z$	Eye Balls Up
To Right	$+a_y$	R. Lateral accel.	Left Lateral G	$+G_y$	Eye Balls Left
To Left	$-a_y$	L. Lateral accel.	Right Lateral G	$-G_y$	Eye Balls Right
ANGULAR MOTION					
Roll Right	$+\dot{p}$		Roll	$-\dot{R}_x$	
Roll Left	$-\dot{p}$			$+\dot{R}_x$	
Pitch Up	$+\dot{q}$		Pitch	$-\dot{R}_y$	
Pitch Down	$-\dot{q}$			$+\dot{R}_y$	
Yaw Right	$+\dot{r}$		Yaw	$+\dot{R}_z$	
Yaw Left	$-\dot{r}$			$-\dot{R}_z$	

FOOTNOTES:

1. Large letter, G, used as unit to express inertial resultant to whole body acceleration in multiples of the magnitude of the acceleration of gravity. Acceleration of gravity, g_0 , = 980.665 cm/sec² or 32.1739 ft/sec²
2. A-P, P-A refers to Anterior-Posterior, Posterior-Anterior.

Sustained Acceleration

Sustained acceleration may be defined as acceleration lasting more than about 1 second, as opposed to transitory or impact acceleration, which lasts less than about 1 second. Although the boundary between impact acceleration and sustained acceleration is indistinct, the effects can usually be used to differentiate between them. That is, the effects of sustained acceleration are primarily physiological, and the effects of impact acceleration are primarily mechanical.'

Sustained acceleration most significantly affects the circulatory system and secondarily affects mental and sensory function. Of less significance, musculoskeletal effects impede movements necessary to control the aircraft or execute emergency procedures. At very high acceleration levels, musculoskeletal injury has been reported.

Three types of sustained acceleration are commonly seen in aviation: linear, which is a change in speed without a change in direction; radial or centripetal, which results from a change in direction without necessarily a change in speed; and angular, which is rotation around a body axis. Each of these types of acceleration has disorienting aspects, however, these are discussed in the chapter on vestibular function.

The physiological effects of G differ markedly, depending on the direction of the G related to the body. Because of this, each G direction will be discussed separately.

“Eyeballs Down” (+G_z) Acceleration

“Eyeballs down” or +G_z acceleration is the most common sustained acceleration experienced by naval aviators, and it is the most likely to have serious consequences. This type of acceleration is usually a result of radial acceleration due to a change in direction.

For an aircraft in a level turn, the G can be calculated by the following formula: $a = v^2/r$

where a = acceleration in ft/s²

v velocity in ft/s

r radius of the turn in ft

The following example is a calculation of G in an aircraft flying at 500 knots and turning with a radius of 2000 ft. (Note that there are 6080 ft/knot and 3600 s/h.)

$$a = (500 \text{ knots})^2/2000 = ((500*6080)/3600)^2/2000 = 356.5 \text{ ft/s}^2$$

$$G = a/g = 356.5\text{ft/s}^2/32.2\text{ft/s}^2 = 11.07 \text{ G}$$

As we shall see, this is well beyond the limits of most naval aviators' capability.

Cardiovascular Effects. For a naval aviator of average stature seated upright, the height of the column of blood from the aortic valve to the eye is about 30 centimeters (cm). At 1 +G_z, this column of blood would result in an approximate pressure drop from heart to eye of 22 millimeters of mercury (mm Hg). Thus, with a mean blood pressure of 100 mm Hg at the aortic valve level, the systolic blood pressure at eye level at 1 +G_z would be 100 minus 22, or 78 mm Hg. For each additional +G_z, the eye level blood pressure is lowered by 22 mm Hg, until at 4.5 G, the mean eye level blood pressure is 0. Therefore, if only the hydrostatic column is considered, the theoretical limit of +G_z tolerance for eye and brain blood flow, and thus eye and brain function, is approximately 4.5 G, unless either the blood pressure at the aortic valve level is increased, or the effective height of the aortic valve to eye blood column is decreased.

Other complexities are added, however, in vivo. As the +G_z level increases, compensatory mechanisms begin to act. Baroreceptors in the aortic arch and carotid arteries sense the decrease in pressure and act to increase the blood flow to the head by three mechanisms: peripheral vasoconstriction, increased heart rate, and increased contractile force of the cardiac muscle. These responses occur about 6-10 seconds after stimulation (see Figure 2-1 and Guyton, 1981), and in very fast onset rates of G, may be too slow to avoid serious neurological consequences. (See section on +G_z neurological effects.) Chemoreceptors play a role as pressure drops and as the arterial oxygen partial pressure (PaO₂) decreases from the respiratory effects of G. The central nervous system (CNS) ischemic response probably plays a role in recovery when head blood pressure drops to 0 for greater than 5 seconds, resulting in loss of consciousness.

Dysrhythmias are frequently seen when subjects are electrocardiographically monitored while undergoing G stress. The most common dysrhythmias associated with +G_z exposure are marked sinus arrhythmia, premature ventricular contractions, and premature atrial contractions (Leverett & Whinnery, 1985, p. 216). It is questionable whether acceleration is more dysrhythmogenic than other physical stresses, such as hard exercise, or whether mechanisms unique to G, such as distortion of heart muscle, have an effect. In healthy aviators, the effects of these dysrhythmias are usually slight, except in rare instances when they may reduce brain blood flow enough to cause neurological symptoms (Whinnery, Laughlin, & Uhl, 1980).

There has been concern for many years that subclinical cardiovascular system damage might occur from high G exposure, causing long-term adverse health effects. In fact, endocardial hemorrhages have been reported in pigs exposed to high G, but there is no evidence that cardiac

damage occurs in humans who are exposed acutely or chronically to G within tolerance limits (Leverett & Whinnery, 1985, p. 227).

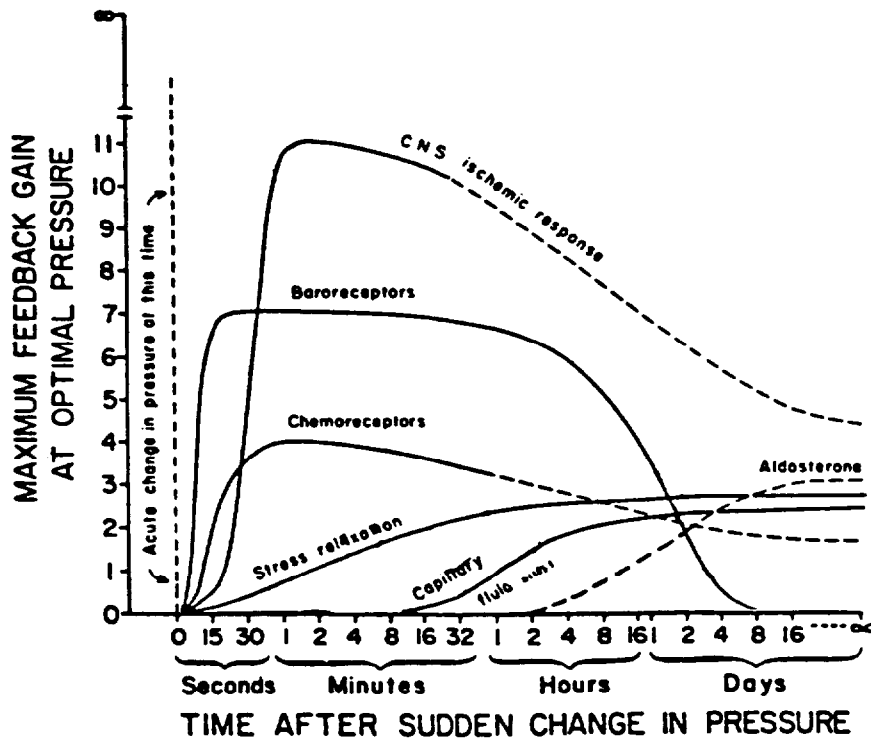

Figure 2-1. Potency of various arterial pressure control mechanisms at different time intervals after the onset of a disturbance to the arterial pressure. Not especially the infinite gain of the renal-body fluid pressure control mechanism that occurs after a few days' time.

Neurological Effects. Most of the CNS and sensory effects of $+G_z$ are a direct result of the cardiovascular effects. For CNS and eye tissue to function, only brief blood flow interruption can be tolerated. If blood flow to these tissues is interrupted, the tissue reserves of oxygen last approximately 5 seconds. As this minuscule reserve is used up, the tissue ceases its normal function. If blood flow is restored after a brief period of malfunction, the tissue resumes functioning with no residual damage. There is, however, a profound and critical difference between the response of the eye and the response of the brain to blood flow loss from $+G_z$. First, blood flow to the eye ceases before blood flow to the brain does, because of the internal pressure of the eye (approximately 16 mm Hg average). Because of this early blood loss difference, vision will fail at about 0.7 G below the $+G_z$ level at which cerebral function fails. This is fortuitous for aviators since it

can provide a visual warning of impending loss of consciousness. Aviators frequently use grayout or tunneling of vision as a way to titrate the G load to avoid more serious consequences, but this technique becomes less reliable as the G onset rate increases. To understand this phenomenon, it is necessary to examine the interactions between the 5-second lag from stoppage of blood flow to eye or brain until the development of eye or brain symptoms, and the onset rate of G. Figure 2-2 illustrates this warning time change at a slow and a fast onset rate of G.

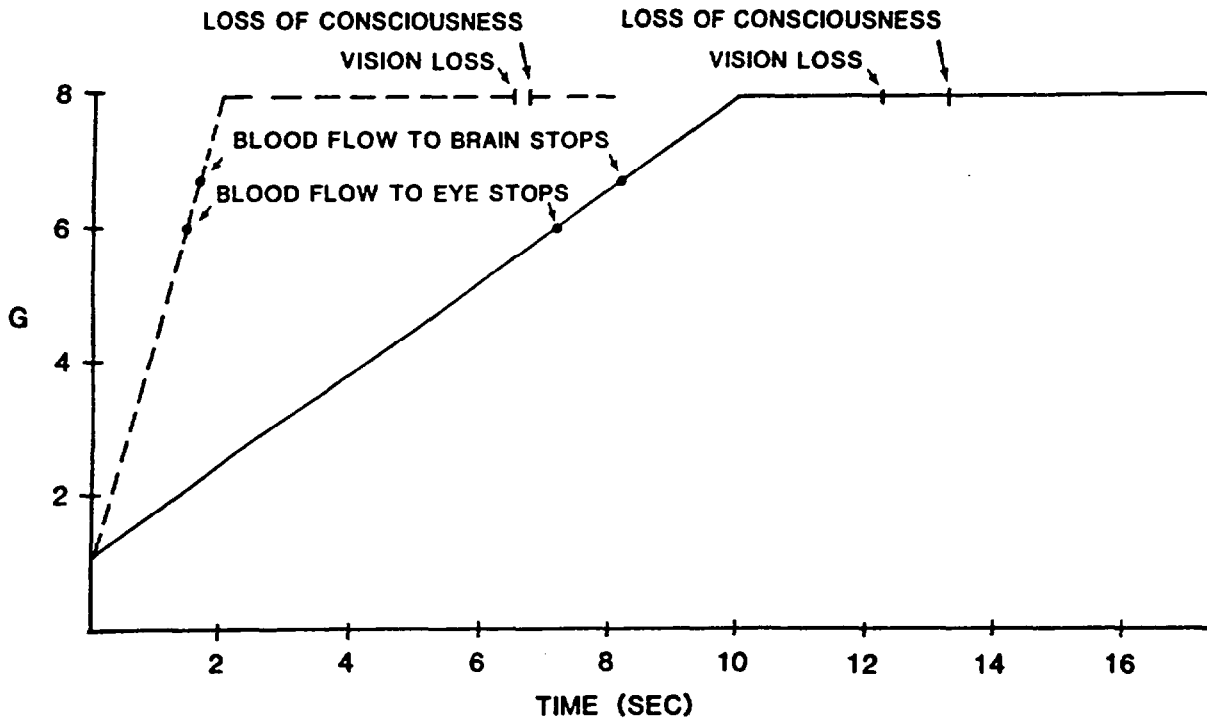

Figure 2-2. An illustration of the reduction in warning time between visual symptoms and G-induced loss of consciousness (GLOC) when G onset rate is increased. The dotted line shows a rapid onset of G to 8G in an aviator who loses blood flow to his eye at 6G and to his brain at 6.7G. Vision loss and GLOC occur 5 sec after blood flow to the respective organ stops. The solid line shows the same aviator experiencing a slower onset rate of G. Note the longer time between visual symptoms and GLOC at the slower onset.

Figure 2-3 further illustrates the physiology of G-induced visual symptoms and loss of consciousness. Note especially the 5-second oxygen reserve during which no eye or brain symptoms occur. This reserve explains why an aviator can bend an airplane with momentary excessive G, have no ill effects, and as a result, develop an inflated perception of his G tolerance. The dip in the curve in Figure 2-3 illustrates the problem caused by the lag in physiological compensatory

Acceleration and Vibration

mechanisms, especially with high onset rates of G. Figure 2-4 illustrates the G-titration strategy using vision symptoms that pilots can use effectively with slow onset rates of G. It also illustrates why this strategy will not always work with aircraft such as the F/A-18 that are capable of high onset rates of G. There simply is not enough time for the visual symptoms to provide warning before G-induced loss of consciousness (GLOC).

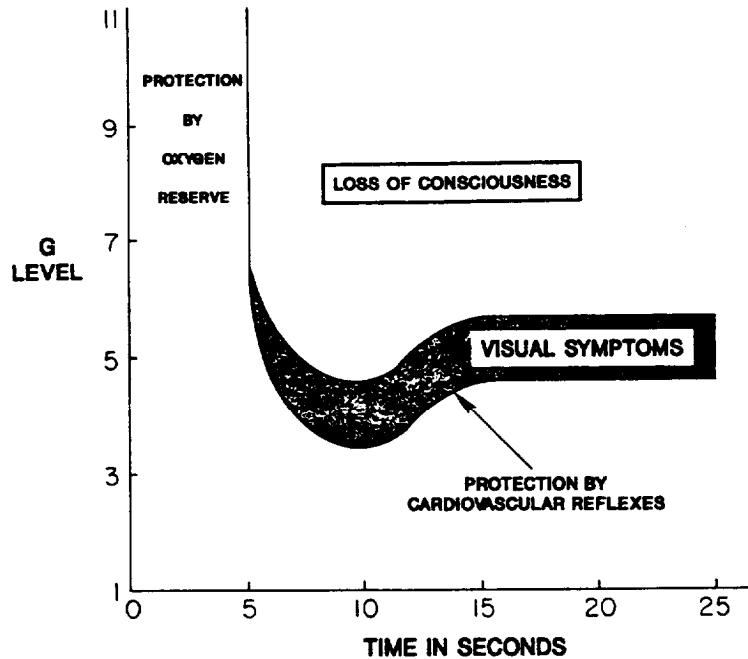

Figure 2-3. Physiology of G-induced loss of consciousness. (NOTE: There is considerable individual variation in G-level at onset of visual and cerebral symptoms.)

Another profound difference between eye and brain response to $+G_z$ is the failure and recovery mode. The eye fails and recovers smoothly when blood flow stops. This can be easily demonstrated by digital pressure on the eye to stop the blood flow (Whinnery, 1979). After about 5 seconds of pressure, vision is progressively lost from peripheral vision to central vision. When blood flow is allowed to resume, vision is smoothly and rapidly recovered. Cerebral failure and recovery is much less graceful and predictable (Houghton, McBride, & Hannah, 1985). After about 5 seconds of blood flow stoppage to the brain, GLOC occurs suddenly and lasts from 10 to 30 seconds (average about 13 seconds). When consciousness is regained, it is usually accompanied by brief seizure-like activity and a period of confusion, which lasts about 12 seconds. During this 12 seconds, the aviator is unable to function effectively. An additional period of up to 2 minutes is required before cognitive and psychomotor performance ability recovers to normal.

PILOTS' G-TITRATION STRATEGY

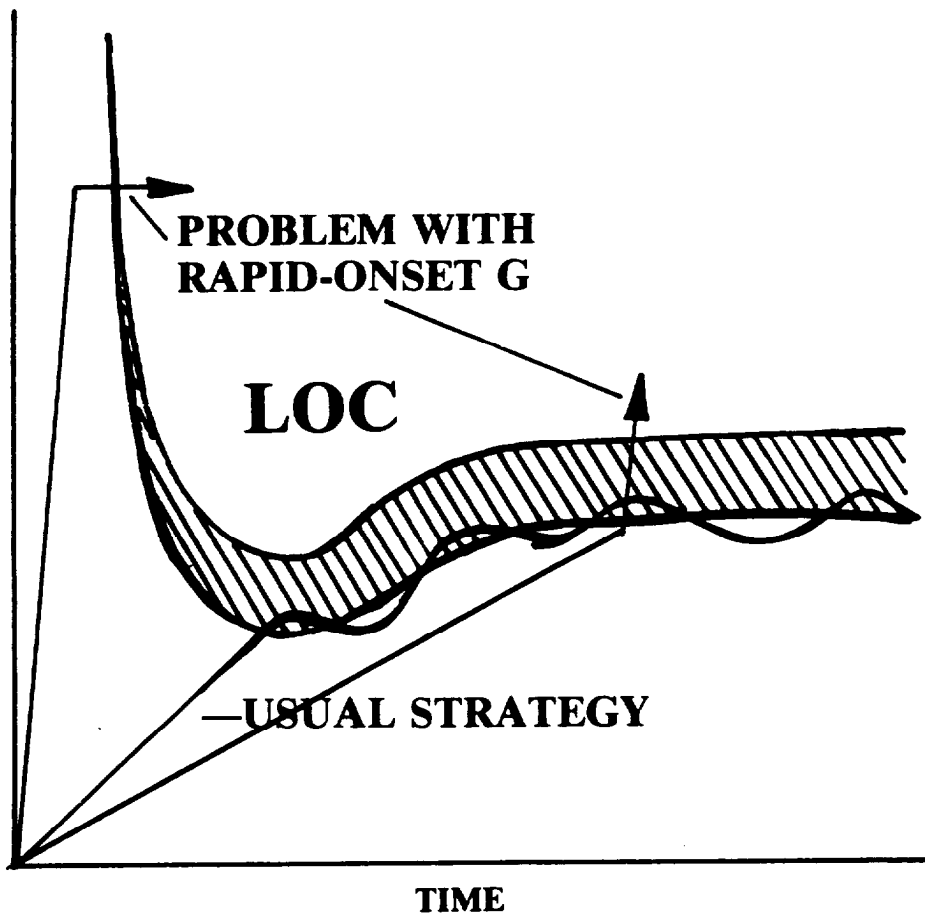

Figure 2-4. Pilots' G-titration strategy.

Although amnesia for the event of GLOC is common (Whinnery & Shaffstall, 1979), 13 percent of naval aviators questioned in an anonymous survey admitted having GLOC in an aircraft, at least once in their career (Johanson, Flick & Terry, 1986). Total loss of the ability to control a high performance, unstable aircraft for half a minute is obviously a condition to be avoided.

Respiratory Effects. There are two primary effects of $+G_z$ on respiratory function. The most serious effect results from a perfusion/ventilation mismatch. As the $+G_z$ increases, the pressure gradient in the lung increases, resulting in reduced perfusion of the upper part of the lung and increased perfusion in the lower part of the lung. This results in an increased physiological dead

Acceleration and Vibration

space in the upper portion and a physiological shunt in the lower portion of the lung, both of which result in a reduced PaO₂. In healthy subjects exposed to +7 G_z for 45 seconds, the PaO₂ decreased from 91.6 mm Hg. to 50.1 mm Hg despite an almost two-fold increase in tidal volume (Leverett & Whinnery, 1985, p 221). This reduced PaO₂ is added to the insult of reduced blood flow to the head and would be expected to contribute to decrements in performance capability.

A second problem is G-induced oxygen atelectasis, or aero-atelectasis. The U.S. Navy uses 100 percent oxygen in most tactical jet aircraft breathing systems to simplify the breathing system, to provide an underwater breathing capacity, and to maximize night vision. Aero-atelectasis, especially in the compressed alveoli of the dependent portion of the lung, occurs more readily when 100 percent O₂ is used than when an inert gas dilutes the breathing gas, due to the more rapid absorption of O₂ from poorly aerated alveoli. The aero-atelectasis sometimes causes mild transient chest pain and coughing after high +G_z maneuvering, but the symptoms are generally not thought to be severe enough to offset the advantages of the 100 percent O₂ systems. This is a controversial subject. The USAF and the RAF have elected to use systems that dilute the oxygen in the breathing system with cabin air up to a present cabin altitude, while the Navy continues to consider that underwater breathing capability more than offsets the mild symptoms of aero-atelectasis.

Musculoskeletal Effects. At 6 +G_z, a 160 pound aviator is pressed into his seat with an equivalent of 960 lbs. As +G_z levels increase, purposeful limb movements become progressively more difficult. Neck and back pain may occur and may be the limiting factor for G tolerance in some aviators. Musculoskeletal physical fitness is very important in limiting this performance decrement and discomfort, and enabling the aviator to accomplish the neck and body movement required to search for enemy aircraft. Weight training is currently being evaluated for its cardiovascular and its musculoskeletal effects on G tolerance and shows promise in both areas.

Tolerance Limits. Tolerance to +G_z varies considerably from person to person, and in a given aviator, varies from day to day. A simplified theoretical case was discussed earlier with the assumption of an aortic valve to eye column height of 30 cm, and a mean blood pressure at the aortic valve level of 100 mm Hg. The point of loss of brain blood flow would theoretically occur at 4.5 G. in actual practice, determination of G tolerance requires defining the measurement method, which is affected by a complex array of compensatory mechanisms and individual differences. Any measurable, repeatable end point could be chosen; for example, mild peripheral vision loss, total vision loss, or loss of consciousness. An accepted measure of tolerance limits is loss of peripheral vision to a central cone of 60° as measured by the subject tracking his peripheral vision on a light bar (Air Standardization Coordinating Committee, 1986). This degree of vision loss occurs roughly 0.7 to 2.0 G lower than GLOC occurs.

Figure 2-5 illustrates G tolerance measured by peripheral light loss (PLL) in an experiment using a moderately rapid (2- second rise time) onset rate with nonaviator subjects (Cohen, 1983). These G tolerance levels are for a specific group of experimental subjects and, therefore, will vary with the population being tested. Figure 2-5 also shows the increase that can be gained by use of the anti-G suit (AGS), the M-1 straining maneuver, and the pelvis and legs elevating seat (PALE), which is equivalent to a 75° seat back angle.

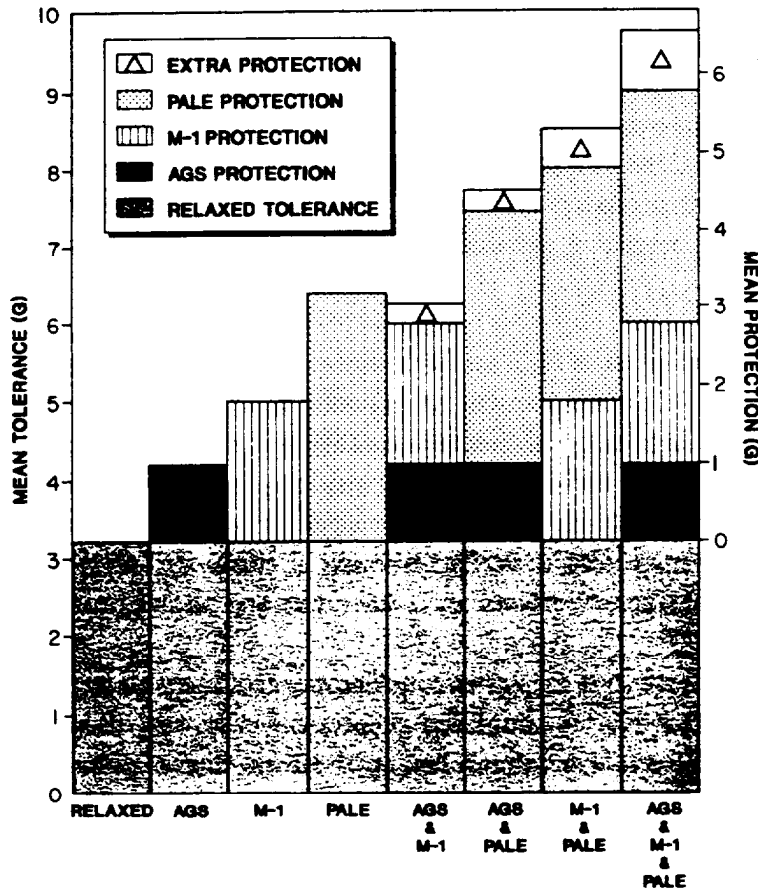

Figure 2-5. Mean tolerance and mean protection under eight experimental conditions. The mean relaxed tolerance of 3.23 G serves as the O-G baseline for acceleration protection. The “extra protection” is the amount of G tolerance beyond the additive effects of the protective measures (Cohen, 1983).

Acceleration and Vibration

A number of factors affect individual G tolerance. Some of them are:

1. Individual differences in the physiological responses.
2. Physical fitness. Although still under investigation, evidence suggests that weight lifting may increase G tolerance, and aerobic exercise, such as running, has no effect or decreases G tolerance.
3. Dehydration lowers G tolerance by reducing plasma volume.
4. Nutrition. Missing meals reduces G tolerance.
5. Recency of G exposure. G tolerance declines rapidly if frequent exposure to G doesn't occur.
6. Most illnesses reduce G tolerance.

Protective Measures for +G_z.

1. *Anti-G suit (AGS)*. The Navy AGS contains inflatable bladders, which cause constriction around the calves, thighs and abdomen. The suit prevents pooling of blood in the lower extremities and abdomen, thus improving venous return to the heart, and elevates the diaphragm, thus slightly reducing the aortic valve to eye column height, reducing the distortion of the heart by G, and assisting in increasing the intrathoracic pressure. The suit is inflated by an aircraft-mounted G valve, which senses G and inflates the G suit in proportion to the G force. Careful fitting of the G suit is critical to its function. A well-fitted G suit will increase G tolerance by about 1 G.

2. *Straining Maneuvers*. Straining maneuvers increase G tolerance by reducing blood pooling in the extremities and abdomen, and by increasing intrathoracic pressure rhythmically to assist the heart in maintaining head level blood pressure. The "M-1" maneuver consists of tightening the muscles of the extremities, abdomen, and chest; pulling the head down between the shoulders; and grunting against a partially closed glottis. This grunt is maintained for about 3 to 5 seconds, relaxed very briefly to allow inhalation and thoracic venous blood return, and then repeated. A properly performed M-1 increases G tolerance by about 2 G and is roughly additive to the G suit protection, together providing about 3 G additional protection. An improperly performed M-1 may actually reduce G tolerance, probably by reducing cardiac return.

Training is critical for the performance of an optimum M-1. The maneuver should be carefully

explained and should be practiced with supervision under $+G_z$ conditions. (It is uncomfortable and perhaps dangerous to practice at 1 G because it markedly increases head level blood pressure.) Practice in an aircraft usually precludes adequate training feedback. A centrifuge provides the best environment for training of the maneuver.

The "L-1" maneuver is identical to the M-1 maneuver except that the glottis is completely closed instead of partially closed. It is as effective as the M-1 and probably preferable because it causes less throat irritation.

3. *Reclined Seat.* Reclining the seat improves G tolerance by reducing the effective aortic valve/eye column height. Figure 2-6 illustrates the effect of various seat back angles (Burns, 1975). The improvement in G tolerance is roughly linear with reduction in effective column height (i.e., at 75° seat back angle, column height is reduced to one half and G tolerance is almost doubled). At high G in the reclined position, G tolerance becomes progressively limited by pain from contact with the seat, from chest compression, and from difficulty inhaling due to the increased weight of the anterior chest wall. These symptoms limit this technique to about 14-15 G maximum. Although reclined seats can dramatically improve G tolerance, they are seldom used because of difficulty providing full use of displays and controls while providing adequate outside vision.

4. *Experimental Protective Techniques.* Several methods for increasing $+G_z$ tolerance are under investigation. These methods include:

a. Positive pressure breathing with a chest counterpressure garment. This technique provides a mechanical assist for increasing intrathoracic pressure, and it may be more effective and less tiring than performing a standard straining maneuver.

b. Pulsating G suits, synchronized to the electrocardiogram. This technique would provide a pulse superimposed on the systolic pulse, producing a higher systolic pressure at head level.

c. Positive pressure breathing with reclined seat. This technique may alleviate inhalation difficulty caused by the increased weight of the anterior chest wall, and thus overcome one disadvantage of the reclined position.

d. Optimization of physical fitness training procedures. This may allow a more forceful straining maneuver with less fatigue.

e. Drugs to increase head level blood pressure on a short-term basis.

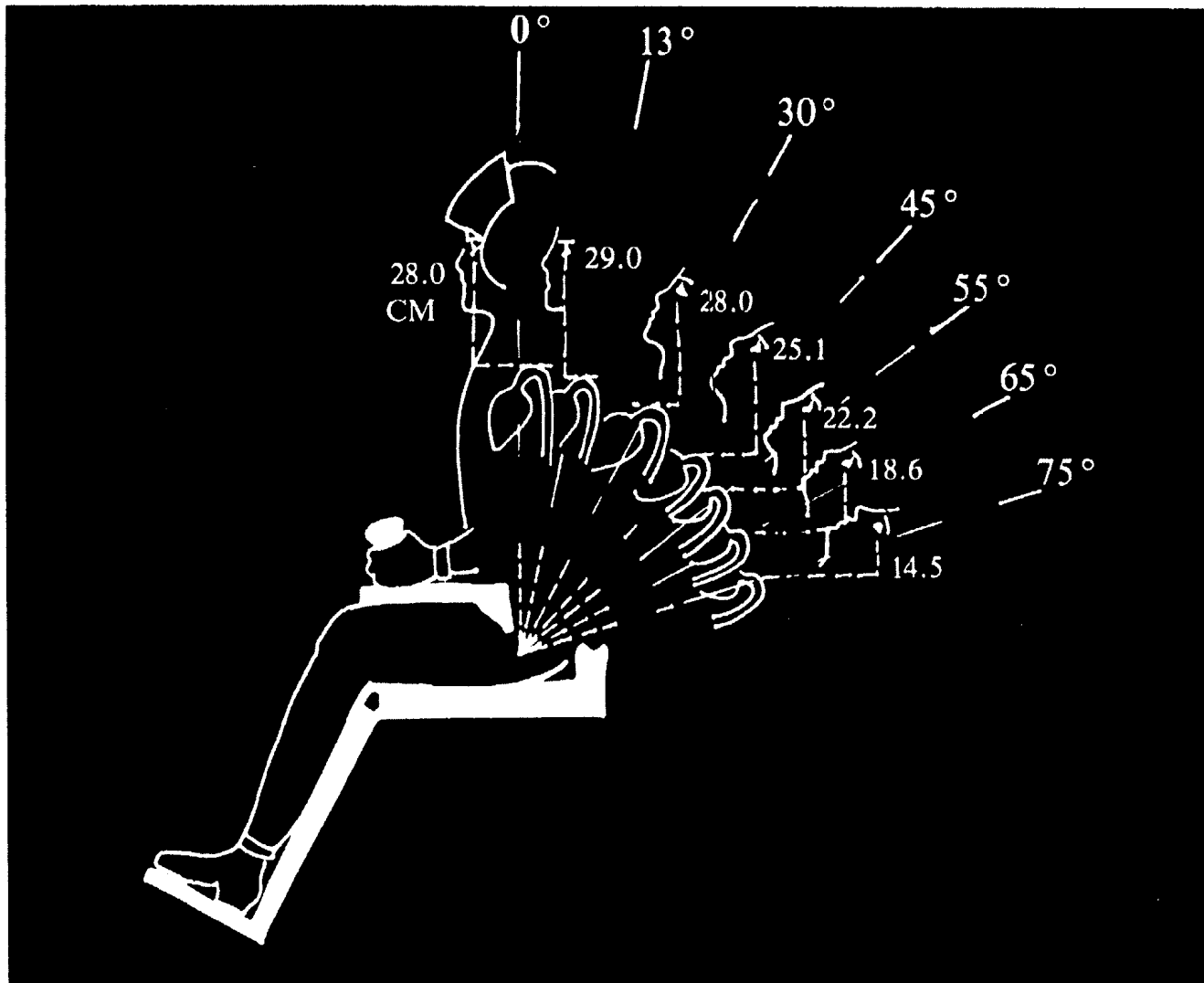

Figure 2-6: Decreased vertical heart-to-eye distances obtained by tilting backward (From Burns, 1975)

“Eyeballs Up” ($-G_z$) Acceleration

Cardiovascular Effects. In $-G_z$ arterial and venous pressure cranial to the heart are increased. It should be remembered that $-1 G_z$ differs by 2 G from the normally experienced G. The increased pressure in the aortic arch and carotid arteries results in a pronounced bradycardia. Increased venous pressure may result in facial edema, petechiae, sinus pain, and headache. A commonly reported “red out” or visual red veil is probably due to the lower lid being forced over the pupil or perhaps to blood staining of the lacrimal fluid from ruptured conjunctival vessels. A rapid transition from $-G_z$ to $+G_z$ would obviously exacerbate the problem of the delayed physiological compensatory mechanisms and may increase the risk of GLOC.

Neurological Effects. Sensory disturbances and severe headache have been reported, as well as confusion and loss of consciousness. These responses are subject to considerable individual variation.

Musculoskeletal Effects. The main musculoskeletal effects are impairment of the aviator's ability to operate controls. For example, in an inverted spin, an inadequately restrained aviator may not be able to manipulate the controls well enough to recover from the spin or to reach the ejection firing control.

Tolerance Limits. Discomfort is the primary limiting factor in voluntary exposure to $-G_z$. Research on the limits has been sketchy due to volunteer subject discomfort and researchers' fears of untoward side effects. An estimate of reasonable limits is $-4.5 G_z$ for 15 seconds and $-3 G_z$ for 30 seconds (Christy, 1971).

Respiratory Effects. Serious respiratory effects have not been reported at the otherwise tolerable levels of $-G_z$.

Protective Measures. The only protective measure currently available is to maintain restraints tight enough to allow operation of both normal and emergency controls.

“Eyeballs In” ($+G_x$) Acceleration

“Eyeballs in” acceleration is experienced during forward acceleration, such as catapult shots, with minimal effects other than decreased musculoskeletal control and increased risk of disorientation. The cardiovascular and respiratory effects are simply extensions of those discussed under $+G_z$ in the special case of a 90° seat back angle.

“Eyeballs Out” ($-G_x$) Acceleration

This is a condition seldom experienced by a naval aviator except from impact or for brief periods during a carrier landing or a ditching. It may occur in abnormal conditions such as a flat spin. For example, a flat spin in an F-14 may exert as much as $-6 G_z$. The primary problem in this instance is musculoskeletal (e.g., difficulty in operating the aircraft controls). A special problem occurs when the pilot's shoulder harness is not locked, and the onset of $-G_x$ is not rapid enough to automatically lock the harness. In this case, the pilot is pressed against the instrument panel and is unable to effectively manipulate the controls.

Cardiovascular and respiratory effects are similar to $+G_x$ effects. One special problem encountered in experimental prone position flying is that lacrimal fluid is not cleared normally from the eye under high $-G_x$ and may cause blurred vision.

“Eyeballs Left/Right” (G_y) Acceleration

Significant G_y is seldom encountered in normal flying, but it may be encountered in future highly maneuverable aircraft. The primary problem in G_y is musculoskeletal, which is increased by the difficulty of restraining the aviator adequately in current seat and restraint designs.

Impact Acceleration

Impact, an acceleration with a pulse duration of about 1 second or less, may be encountered in normal as well as emergency phases of naval aviation. The flight surgeon investigating an accident will often find it necessary to determine the potential survivability of a particular crash situation. Such determinations are predicated on a knowledge of actual human tolerance to impact. Much impact research has been conducted with regard to automotive and aviation crashes, but many questions remain unanswered. No hard and fast tolerance limits to human impact acceleration have been established, and even estimates must be made while carefully considering a number of factors. Before discussing the human tolerance limits for impact, some discussion of the complexity of the problem is necessary so that the ambiguity in setting tolerance limits will be understood.

Human tolerance to impact acceleration is a function of the energy transferred to the body by the impact, or the work done by the impact. This can be calculated by one of the following equations:

$$E = 1/2 MV^2 \text{ where } E = \text{energy}$$

$$M = \text{mass}$$

$$V = \text{velocity (The velocity change during the impact)}$$

or $W = Fd$ where $W = \text{work}$

$F = \text{force} = \text{mass} * \text{acceleration}$

$d = \text{distance over which the force acts.}$

The units for both E and W are $\text{kg M}^2/\text{s}^2$ or Newton-meters and so are equivalent. Peak acceleration alone does not account for the injury potential of an impact, although maximum G is often used to estimate the injury potential of an impact. Both the maximum G and the time over which the G acts are important factors in determining the injury potential. Onset rate of G is also important because body parts have characteristic resonance frequencies, and if the onset rate provides a frequency input in the range of these resonance frequencies, an amplified response of the body part may occur. The complexity of most impact acceleration waveforms is an additional complication. Figure 2-7 is a typical impact G versus time wave form. To say that a certain G lasted a certain number of seconds is an oversimplified approach to the problem.

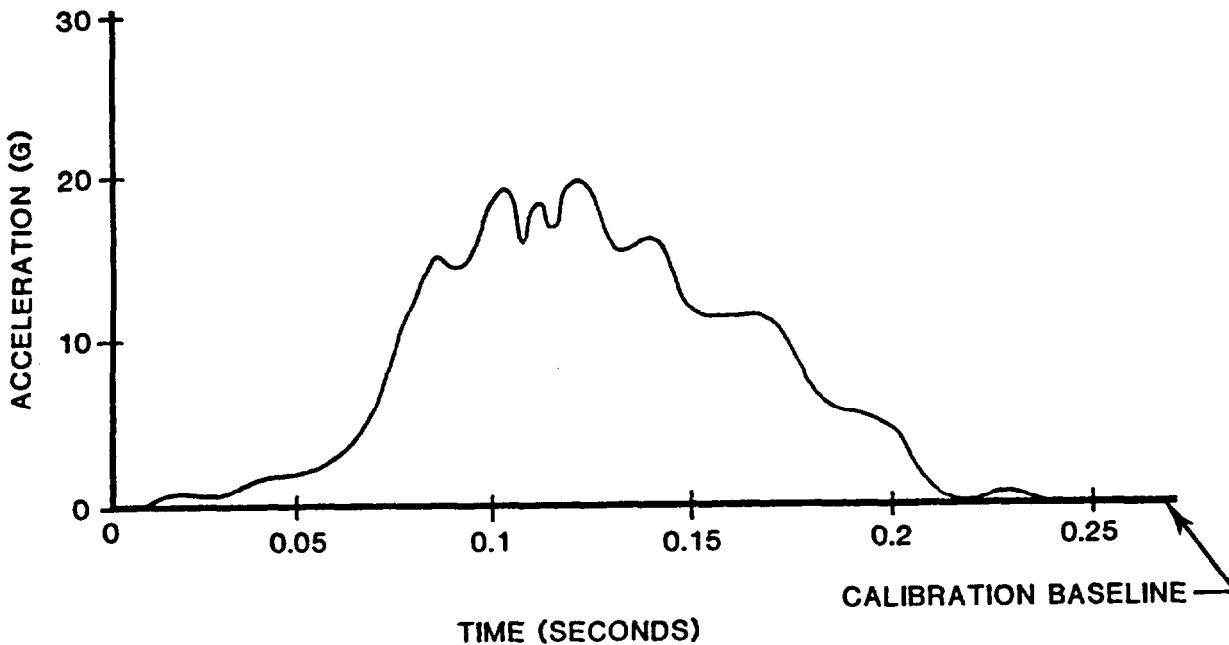

Figure 2-7. A typical impact waveform.

The following are necessary to adequately describe the injury causing potential of an impact:

1. The acceleration pulse shape.
2. The acceleration direction
3. The acceleration duration from which a velocity change can be computed.

Acceleration and Vibration

4. The acceleration magnitude.
5. The type of seat and restraint system.
6. The physical characteristics of the aircrewman.
7. The secondary impact of body parts with the airframe or other objects.
8. The distribution of the force over body parts.

With this knowledge, one of several existing mathematical models for predicting injury probability can be used, or the wave form can be simplified to a trapezoidal form and compared against available tables of injury probability. These approaches are still inaccurate for the following reasons:

1. Humans may not normally be taken to impact injury limits experimentally, and there is a wide, uncharted gap between voluntary impact limits and the accelerations that cause injuries in accidents.

2. The accelerations involved in uninstrumented accidents are difficult to characterize.

3. Experiments using human subjects, or substitutes such as animals or cadavers, vary widely in restraints, instrumentation, and parameters reported. These experiments are, therefore, difficult to compare.

4. Animals vary enormously in impact tolerance due to size, anatomical and physiological differences. Extrapolation of animal injury findings to human tolerance must be done very cautiously.

5. Experimentally produced injury criteria are valid only when applied to situations meeting the conditions of the experiments. Changes in body support, restraint systems, or type of subject can change tolerances significantly.

The purpose of this cautious prologue is to emphasize the importance of recognizing single number listings of acceleration impact tolerance limits for what they are--very rough estimates.

Because the existing injury data base is inadequate, every flight surgeon investigating a mishap has an obligation to carefully document injury patterns and severity, to attempt to correlate the injuries with calculated acceleration forces, and to evaluate the function of protective equipment. Mishaps resulting in injuries, loss of life, or loss of aircraft may provide extremely valuable contributions to our understanding of injury causation and prevention, and it is unconscionable to waste these valuable data through careless or incomplete investigation.

A data base commonly used to establish whole body impact acceleration tolerance is a set of curves compiled by Eiband in 1959, from a literature review of voluntary, accident, and animal studies. Combined with later studies, this has provided a basis for estimation of tolerance limits. Some "Eiband Curves" are reproduced in Tables 2-2 through 2-5. Note that injury probability is affected by the duration of the acceleration as well as its intensity.

Table 2-2
+G_x Acceleration Tolerance Limits

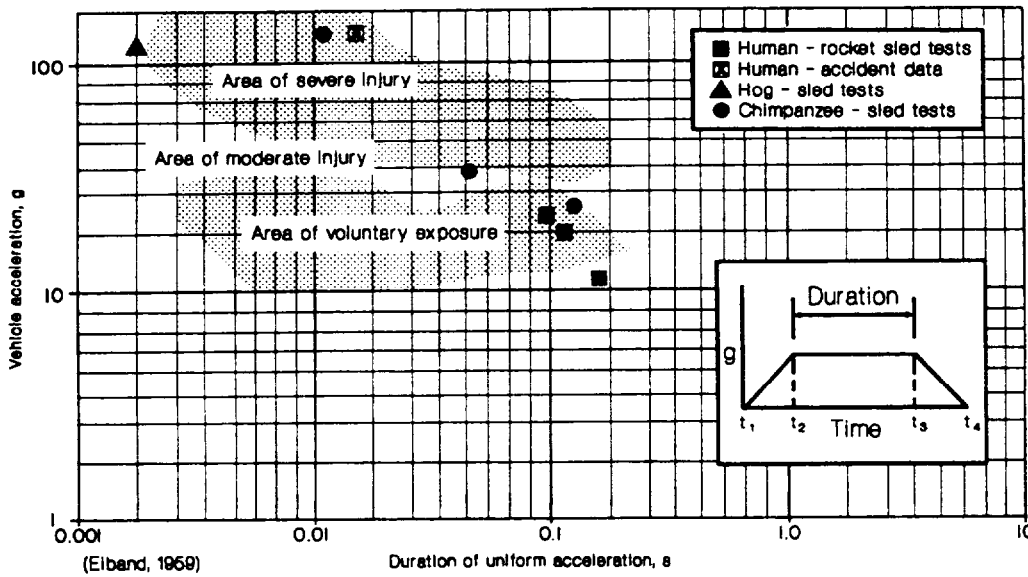

Voluntary instrumented impact exposures have provided some insight into various tolerance limits. Again, G alone is not an adequate description of the impact energy unless time and onset rate of G are included.

An experimental subject survived a 45 -G_x acceleration with a 493 G/s onset rate and a velocity change of 56 m/s with minor reversible injury (Stapp, 1951). A well-supported subject survived 40.4 +G_x with an onset rate of 2139 G/s and a velocity change of 14.8 m/s with transient shock and syncope (Beeding & Mosley, 1960). In the ± Z and the ± Y axes, volunteer subjects have been exposed to impacts in the range of 15-20 G with velocity changes in the range of 8-12 m/s with no injury. Occasional bradycardia and syncope at these levels are unexplained, but possible mechanisms are CNS/brainstem stress, or stimulation of the carotid or aortic pressure sensors.

Acceleration and Vibration

Table 2-3
 $-G_x$ Acceleration Tolerance Limits

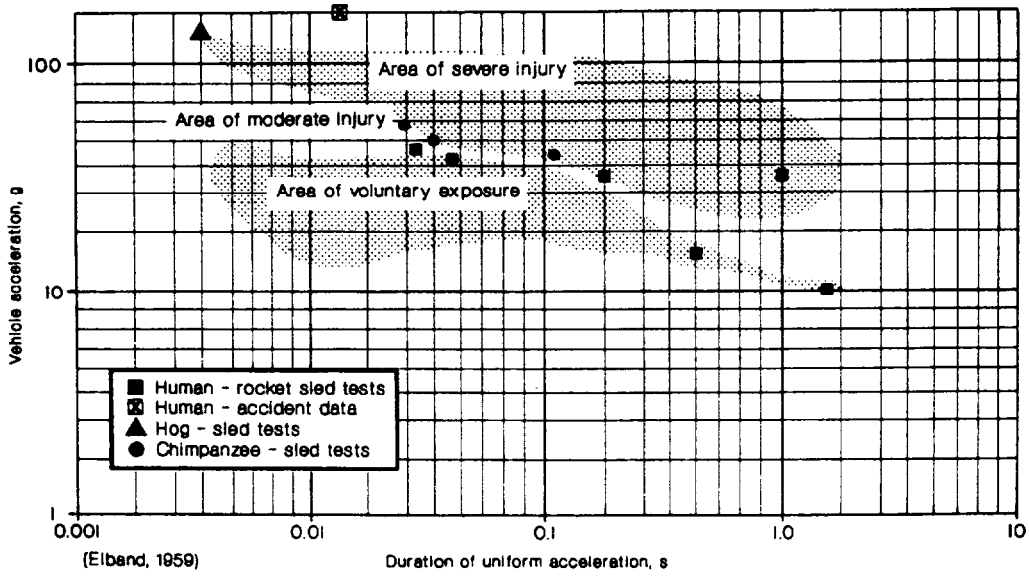

Table 2-4
 $+G_z$ Acceleration Tolerance Limits

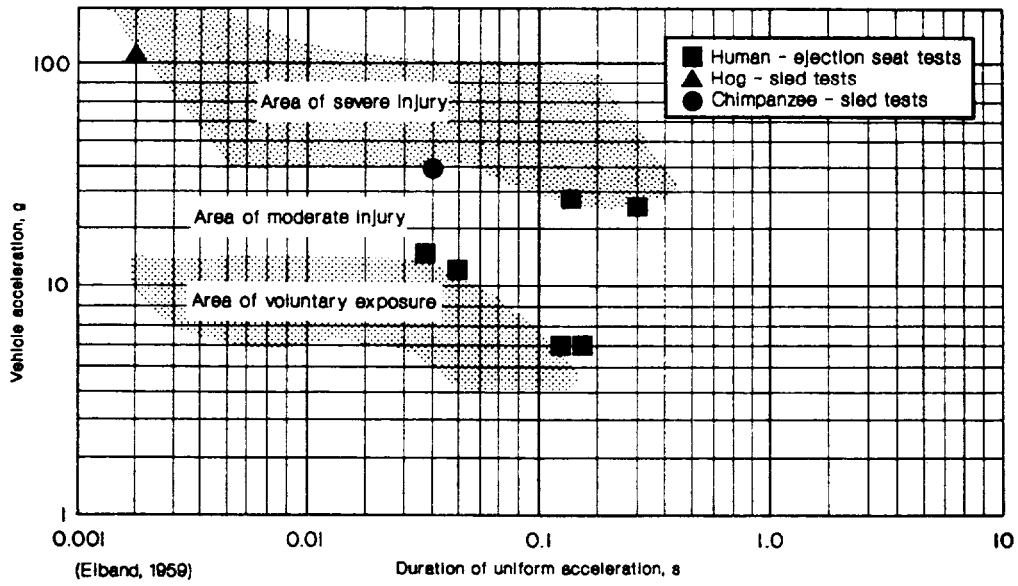
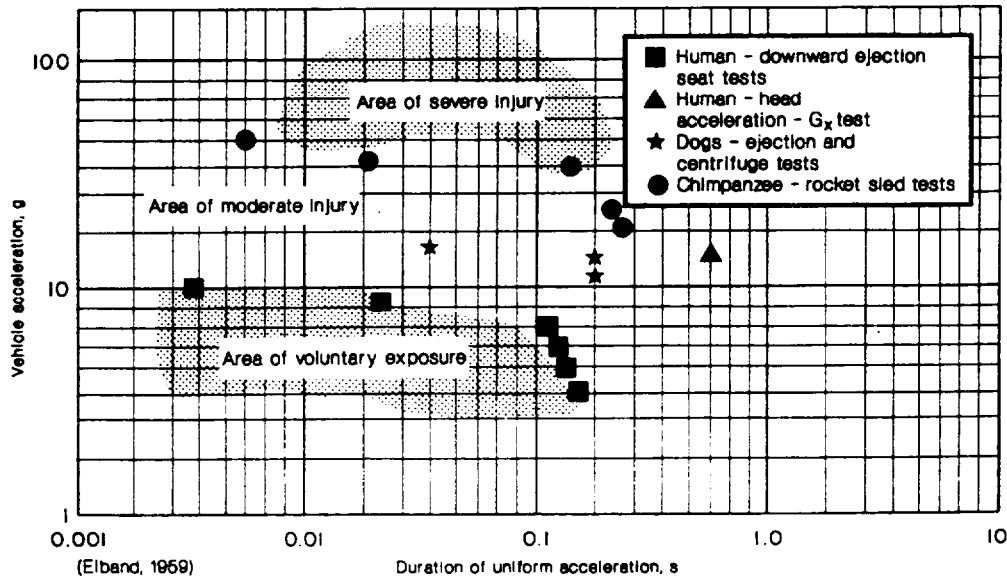

Table 2-5
 -G_z Acceleration Tolerance Limits



It is important to recognize that the above levels of impact were sustained by well-supported and well-restrained subjects. Restraint systems in aircraft are limited by weight and space requirements, and the need for aircrew mobility. Actual tolerance limits in the aircraft will probably be lower. Table 2-6 (from Lewis, 1974) contains estimates of tolerance limits that may be applicable in operational aircraft.

Table 2-6
 Human Whole-Body Impact Tolerance Limits Based on 250 G/sec Onset Rate

Direction of Impact	Load Limit Over Time		
+G _z	20	G over 0.1	second
-G _z	15	G over 0.1	second
+G _x	83	G over 0.04	second
-G _x (full restraint)	45	G over 0.1	second
	24	G over 0.2	second
-G _x (lap belt)	13	G over 0.002	second (ruptured bladder)
	27	G over 0.002	second (muscle strain)
±G _y	9	G over 0.1	second

(Lewis, 1974)

In stating tolerance limits, “tolerance” should be defined (e.g., no injury, minor injury, or simply survival). Mathematical models are being developed, which include some of the complexities of calculation of injury potential. Examples are the Dynamic Response Index (DRI), which is an attempt to estimate risk of spinal injury from ejection seats, and the Head Injury Criteria (HIC), which is an attempt to estimate the risk of head injury from a given head impact. These and other mathematical models, although not foolproof, enable an estimation of injury potential if the acceleration profile and other pertinent information are available. None of these models has gained universal acceptance.

Impact Protection

In general, a spreading out of a given amount of energy over a longer time span and over a larger body surface area will reduce the likelihood of injury. Obviously, a deceleration from 60 knots to a stop in 1 second is more likely to cause injury than the same deceleration in 10 seconds. Thus, the length of the fuselage structure (between the impact point and aircrew) and its crush characteristics are critical in reducing injury. For the same reason, crashworthy seats have been developed in which collapse or crushing of the seat supports is used in a controlled manner to spread the energy of impact over a longer time span, Reducing relative motion and stress between body parts by improvements in restraints will also reduce the risk of injury.

The impact injury potential of an aircraft occupant may be amplified in several ways. For instance, if the occupant is poorly restrained, a body part, such as the head, may continue in its initial direction and speed until it impacts an aircraft structure. The head will thus absorb the total energy of the deceleration over a much shorter time than if the head had been well restrained. In another example, if an ejection occurs with a soft cushion on the ejection seat, the seat occupant remains essentially motionless while the seat accelerates upward, and the cushion compresses. After complete cushion compression, the occupant is accelerated over a shorter time period than if he had been closely coupled to the seat at the onset of the acceleration. A number of protective measures are designed to reduce impact amplification, for example, by restraining the occupant as tightly as possible and by limiting the thickness of cushioning materials in ejection seats.

The more firmly the occupant is coupled to the seat, the more impact protection is provided, but there is a tradeoff between restraint effectiveness and weight, space, comfort, and mobility requirements of the aircrew. In Stapp’s (1951) record $-G_x$ impact experiment, he had almost twice the area of restraint webbing as most military aircraft restraints.

The seats must be fixed to the aircraft structure so as not to break loose at otherwise survivable impact forces, or the seat occupant may experience an amplified impact as discussed above.

Equipment and objects must be firmly attached to the aircraft structure so as to avoid becoming missiles in an otherwise survivable crash. (This is the rationale for 40-G coffee pot attachments in aircraft limited to 3 G in normal operation).

The aircraft structure should be strong enough to prevent intrusion into the crew space. All other protective mechanisms are useless if the aircrew station cannot be occupied because of crushing of the aircraft structure into the space.

To restrain the head and neck and still allow full mobility is a difficult problem. Consequently, head and neck injuries are the most common serious injuries in aircraft impacts. This problem is sometimes exacerbated by the protective helmet, which increases the mass and changes the center of gravity of the head/neck/helmet combination, thereby increasing the force exerted on the neck in some impacts. The flight helmet is designed to attenuate impact to the head by both increasing the time span for absorption of the energy, and by spreading the energy over a wider surface area. The attenuation material used in the helmet will provide maximum protection, if it is nonelastic (crushable) to prevent a "bounce", and just dense enough to completely crush at a force level that would be expected to cause severe injury. That is, if the attenuation material transmits enough energy to cause severe head injury before it completely crushes, it is too dense to spread the impact energy over the maximum available time span.

Physiological and Pathological Effects of Impact

Head injuries are the most common causes of crash fatalities. Frontal impacts tend to be less severe clinically than temporal or occipital impacts since basilar skull fractures and consequent involvement of the adjacent intracranial structures are generally far more serious than frontal impact trauma (von Gierke & Brinkley, 1975). Estimates of acceleration and time necessary to produce concussion injury have been developed by Wayne State University (1980), primarily from cadaver studies (see Figure 2-8).

Spinal impact associated with ejection may result in vertebral compression fractures. The most common fracture sites are T-12 and L-1, although other sites may be involved due to poor body position (Rotondo, 1975). The erect or hyperextended posture is ideal for ejections, but during normal operations, pilots are usually in a flexed position.

Although $-G_z$ impact has not been well studied, intracranial hemorrhage is speculated to be the limiting factor. This has not been well supported, however, by animal studies.

In a well-supported and restrained individual, $+G_x$ impact causes various degrees of shock,

which is the main limiting factor. Bradycardia due to vagal activity has been observed. Some evidence of respiratory damage has also been found (von Gierke & Brinkley, 1975). Contrary to the general rule for impact, $-G_x$ or eyeballs-out impact may lead to increased hydrostatic pressure in the central retinal artery, causing conjunctivitis and retinal symptoms, such as scotomata (Lewis, 1974; von Gierke & Brinkley, 1975). Where a lap belt provides the only restraint, $-G_x$ impact can lead to a ruptured bladder. Lateral impact ($+G_y$), though not well studied, can lead to cardiovascular shock.

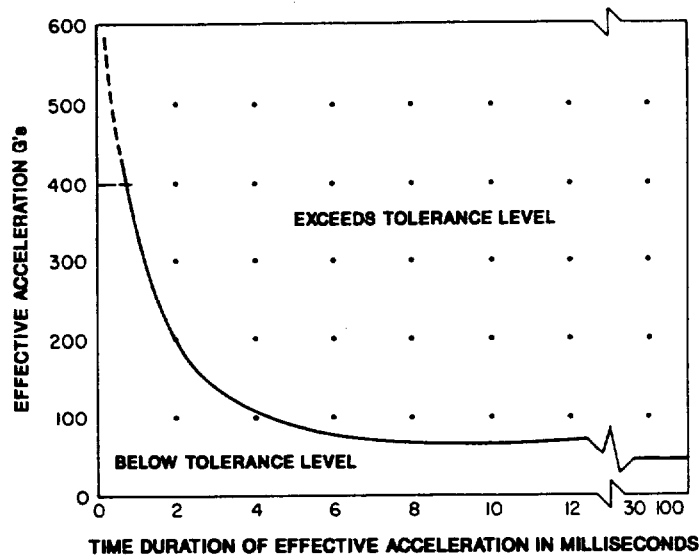

Figure 2-8. Impact tolerance for the human brain in forehead impacts against plane, unyielding surfaces (SAE, 1980).

Ballo and McMeekin (1976) provide further details of the pathological effects of impact. Understanding these effects on various body parts may be valuable in estimating the forces in a crash and in evaluating the effectiveness of restraints and life support equipment.

Vibration

Vibration has commonly been considered more of an engineering problem than a medical one. It is, however, a commonplace problem in the world of naval aviation and one with far-reaching implications for the aviator's personal comfort, health and performance. Thus, it is imperative that the operational flight surgeon have a working knowledge of vibration and its effects on man.

Definitions and Terminology

In everyday terms, vibration means shaking. In physical terms, it is a series of velocity reversals, implying both displacement and acceleration/deceleration. It is described in terms of its frequency, amplitude, anatomical direction with regard to the body, and duration. Frequency is usually expressed in terms of cycles per second, or hertz (Hz). Amplitude, the extent of oscillation, is measured in meters or smaller metric units. The intensity, an extension of the amplitude, is described in terms of its acceleration component, expressed in G. Complex vibrations are often described in terms of the root-mean-square (RMS) intensity, a time-averaged value. The output of many electronic instruments for vibration measurement is proportional to the RMS. For more information see von Gierke, Nixon, and Guignard, 1975.

There are four different types of vibration. Sinusoidal or simple harmonic vibration is composed of a single frequency. When two or more sinusoidal vibrations are added together, a compound harmonic vibration results. When the vibration is totally irregular and unpredictable, it is termed a random vibration. Finally, harmonic vibrations can be added to random ones; Graphic examples of these vibrations are pictured in Figure 2-9.

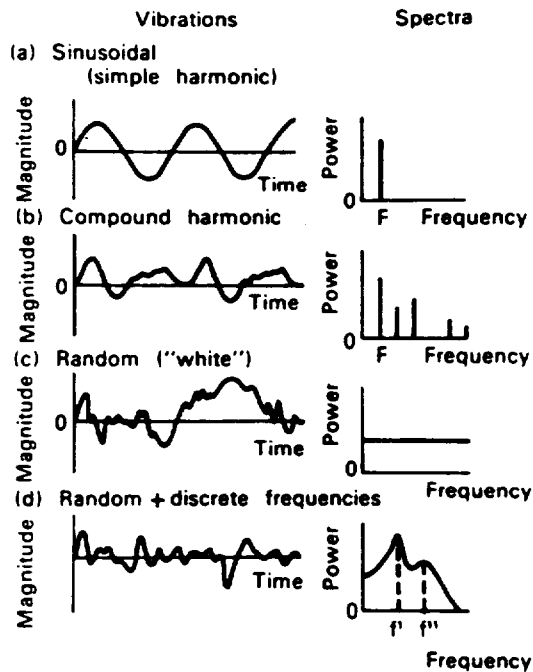

Figure 2-9. Diagram of waveforms and idealized power spectra of typical varieties of vibration (vonGierke, Nixon, & Guignard, 1975).

Resonance

Any vibrating system has one or more characteristic frequencies at which forced vibration will elicit maximum or amplification response. The system is said to resonate at that frequency. The amount of amplification at resonance is inversely related to the amount of damping, the process opposing vibration, within the system.

The human body can be thought of as a complex vibrating system with a number of subsystems displaying different resonance characteristics. Such a system is illustrated in Figure 2-10.

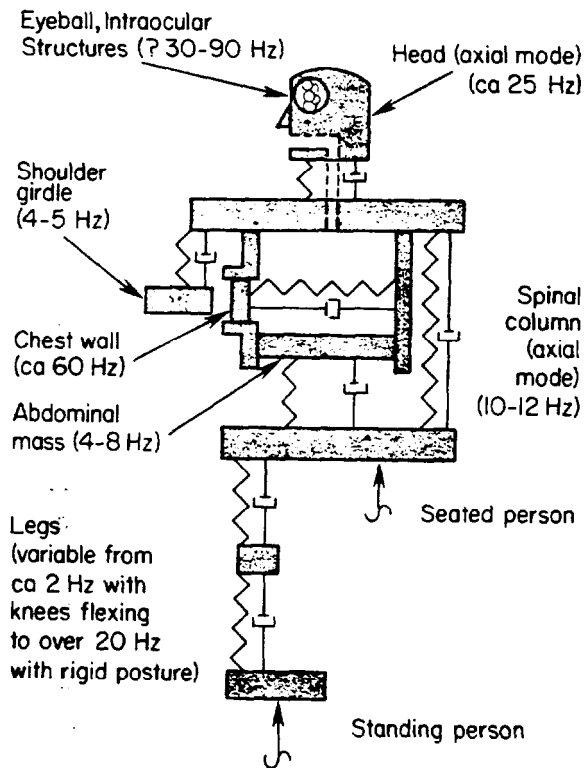

Figure 2-10. Mechanical model (diagrammatic) of seated and standing man (vonGierke, Nixon, & Guignard, 1975).

Sources of Vibration in Naval Aviation

The sources of vibration in naval aviation are myriad. Listed below are some of the principal sources, after von Gierke and Clarke (1971).

Ejection. Once free of the rails, an ejection seat system seeks a stable configuration in the airstream. This normally sets up an oscillation around the center of the seat-man system in the range of 3 to 10 Hz and at a magnitude of 10° to 30°. These vibrations normally damp out rather quickly, but the relatively large oscillations impose considerable threat of flail injury, especially when combined with high aircraft speeds.

Low Altitude, High-Speed Flight. Many current military missions include low altitude, high speed flight in an attempt to avoid radar detection. Gust effects in such flights can introduce complicated vibrations in five degrees of freedom, ranging from about 1 to 10 Hz. This can present clinical problems in the areas of vision, speech, respiratory effort, and musculoskeletal stress similar to a high-speed Jeep ride over an open field.

Terrain Following. In order to fly in the low-level, high-speed profile, many modern aircraft have systems that allow flight close to the contour of the terrain. Such systems, whether manual or automatic, can induce vibration spectra between 0.01 Hz and 0.1 Hz. This is in addition to the gust response and can add the clinical problem of motion sickness.

Storm and Clear Air Turbulence. Storms and clear air turbulence impart vibration spectra that are similar to low altitude, high-speed flight. These vibrations are generally in the very low frequency range, but clear air turbulence can occasionally be of such high frequency and intensity as to preclude control of an aircraft.

Helicopter Vibrations. Vibrations are perhaps of greater importance in helicopters than in any other type of naval aircraft. These vibrations arise from mechanical and atmospheric sources, although the atmospheric conditions are not as important as in fixed wing aircraft due to the lower airspeeds. Vibrations in the 3 to 12 Hz range are induced by the main rotor blades, the actual frequency being related to the number of blades. Tail rotors produce higher frequency vibrations, in the range of 20 to 25 Hz. Vibrations produced by the transmission are less well defined. These generally low amplitude vibrations have clinical significance by virtue of the prolonged exposures involved, where physical fatigue results from continuous bracing. Ill-defined musculoskeletal complaints, such as neck and back pain, appear with increased frequency in the rotary wing community.

V/STOL Aircraft. V/STOL (Vertical/Short Takeoff and Landing) aircraft in low hover appear to exhibit low frequency range vibrations similar to those found with helicopters. Their significance, however, seems to lie more in their effect on the pilot's response time than in any purely clinical effect.

Effects of Vibration on the Body

A number of factors modify the effects of vibration on humans, including tissue resonance, duration of exposure, individual variations, and other simultaneous environmental stresses. For example, acceleration increases the body's rigidity, reducing its shock-absorbing properties and increasing the transmission of vibration energy to the internal organs (Antipov, Davydov, Verigo & Svirezhev, 1975). The effects of vibration on the body are determined by the frequency ranges involved.

Effects at less than 2 Hz. Vibrations in the frequency range of 0.1 to 0.7 Hz most often produce motion sickness in humans. Vibrations of 1 to 2 Hz are generally associated with increases in pulmonary ventilation, heart rate, and sweat production above that level considered normal for any other stress present.

Effects from 2 to 12 Hz. Tolerance in this frequency range is usually limited by substernal or subcostal chest pain, with thresholds at approximately 1 to 2 G_z and 2 to 3 G_x . The etiology of the pain is the same for both axes of vibration: displacement of the abdominal and thoracic viscera induces stretching of the chest wall, with torsion at the costochondral junctions of the ribs. Dyspnea is the second most common symptom in this range, apparently with the same etiology as chest pain. Centrally induced hyperventilation can be produced by vibrations around two axes at acceleration amplitudes above 0.5 G in the range of 1 to 10 Hz.

Cardiovascular effects are maximized in $G_z \pm g_z$ (i.e., a G_z -acceleration environment with interposing g_z vibration) at 3 to 6 Hz and in $G_x \pm g_x$ at 6 to 10 Hz. The changes seen are increases in heart rate, arterial blood pressure, central venous pressure, and cardiac output; these are accompanied by a corresponding decrease in peripheral resistance. These changes all resemble nonspecific exercise responses.

Abdominal discomfort and testicular pain are common complaints due to stretching of viscera and force applied to the spermatic cord, respectively.

The headache commonly associated with this frequency range has several explanations. In a $G_z \pm g_z$ environment, the mechanical forces are not well attenuated by the skeletal system. In a $G_x \pm g_x$ environment, the head is forced out of phase with the headrest and repeatedly impacts against it. In $G_z \pm g_y$ environments, the problem is the same only more so; strain, spasm, and soreness of the neck are added to the symptoms.

Finally, bloody stools, transient albuminuria, and transient hematuria are occasionally seen in

helicopter pilots flying heavy schedules. Such symptoms are attributed to vibration, and they usually disappear after a few days rest.

Effects above 12 Hz. In these frequencies, there is more concern about effects on performance (vision, speech, fatigue) than about injuries.

Effects of Vibration on Performance.

Vibration can greatly affect performance by inducing visual decrements. Frequencies below 2 Hz have little effect, but between 2 and 12 Hz, relatively large displacements of the body with respect to a given point on the instrument panel contribute to increasing visual impairment. The frequency ranges of 25 to 40 Hz and 60 to 90 Hz, however, lead to the greatest visual impairment due to the resonance of the head and eyeballs respectively (von Gierke & Clark, 1971).

Performance can also be modified by vibratory effects on speech. Pitch is increased due to generalized muscle tension during exposure. Single-word intelligibility is decreased as a direct function of vibration magnitude and frequency. Speech is least understandable with $G_z \pm g_z$ in the same low frequencies that induce resonance of the thoraco-abdominal viscera. These problems underscore the importance of standard phraseology in naval aviation; this is, if a word is expected or in a familiar context, it is much more likely to be understood, even if speech is degraded, than if random phraseology is used.

Very low frequency, high-amplitude vibrations often cause pilots to postpone flight corrections until after the short surge of vibration is past. This could be an important contributor to pilot-induced aircraft oscillations. Vibrations in the 2 to 12 Hz range cause involuntary movement of the extremities, which, while not forcing control errors, may hinder fine knob adjustment and writing.

Pathological Effects of Vibration

Animal experiments indicate that acute human injury from exposure to high levels of whole body vibration should resemble impact injuries from accelerations of comparable magnitude and direction. Chronic occupational exposure to vibrational stress has been implicated in a number of disease processes, including Raynaud's phenomena, neuritis, decalcification and cysts of the carpi and long bones of the forearm, cutaneous scleroderma, osteoarthritis, Dupuytren's contracture, bursitis, tenosynovitis, amyotrophic lateral sclerosis, carpal tunnel syndrome, Keinbock's disease, and periodontal disease (Haskell, 1975; Strandness, 1974; Wasserman, 1976; Williams, 1975). *In* most of these cases, the role of vibration has not been firmly established, and much work remains to be done in the area.

Vibration Exposure Standards

The International Organization for Standardization (ISO) has formed recommendations for whole body vibration exposure standards. A number of countries, including the United States, are currently in the process of adopting these or similar standards. The ISO recommendations (ISO, 1985) are summarized in Figures 2-11 through 2-14. These standards are necessarily subject to change. They are certain to come under much scrutiny, and refinement is inevitable.

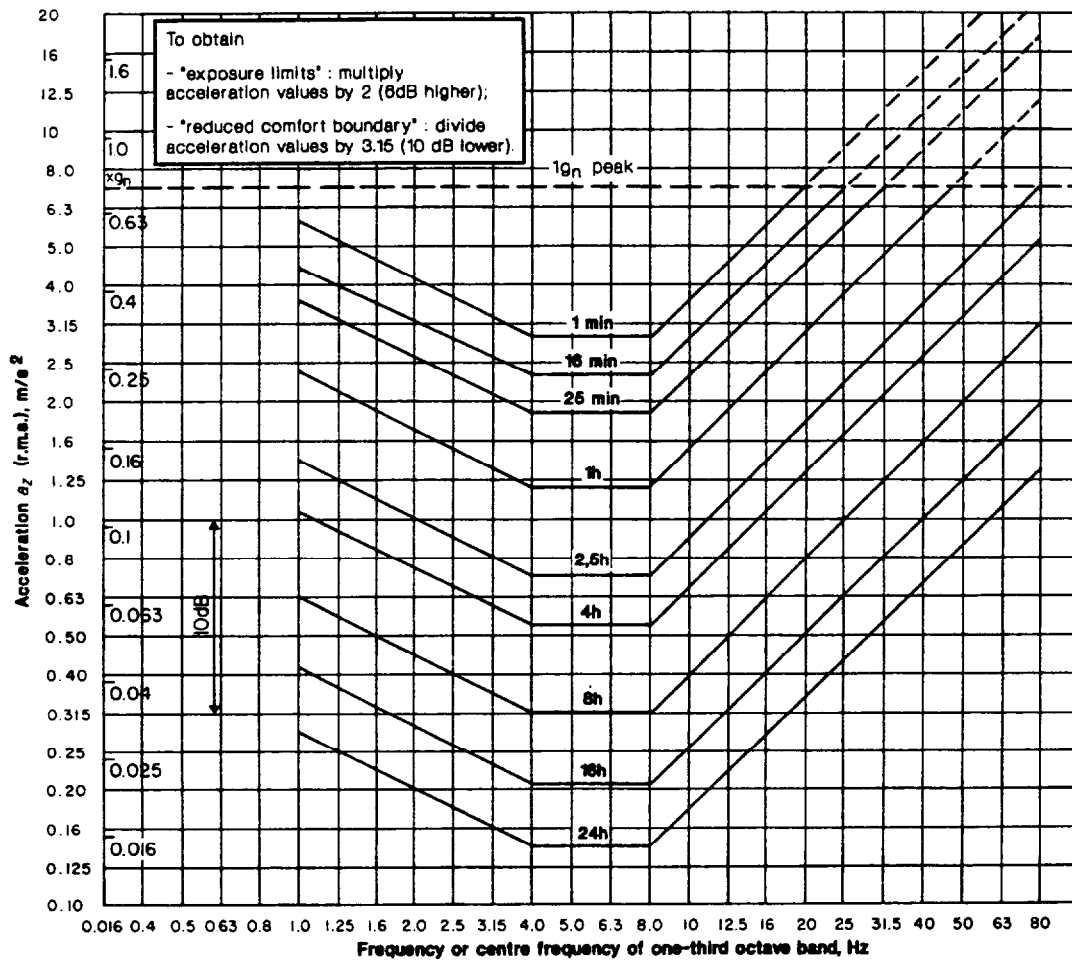

Figure 2-11. Longitudinal (a.) acceleration limits as a function of frequency and exposure time; "fatigue-decreased proficiency boundary" (ISO, 1985).

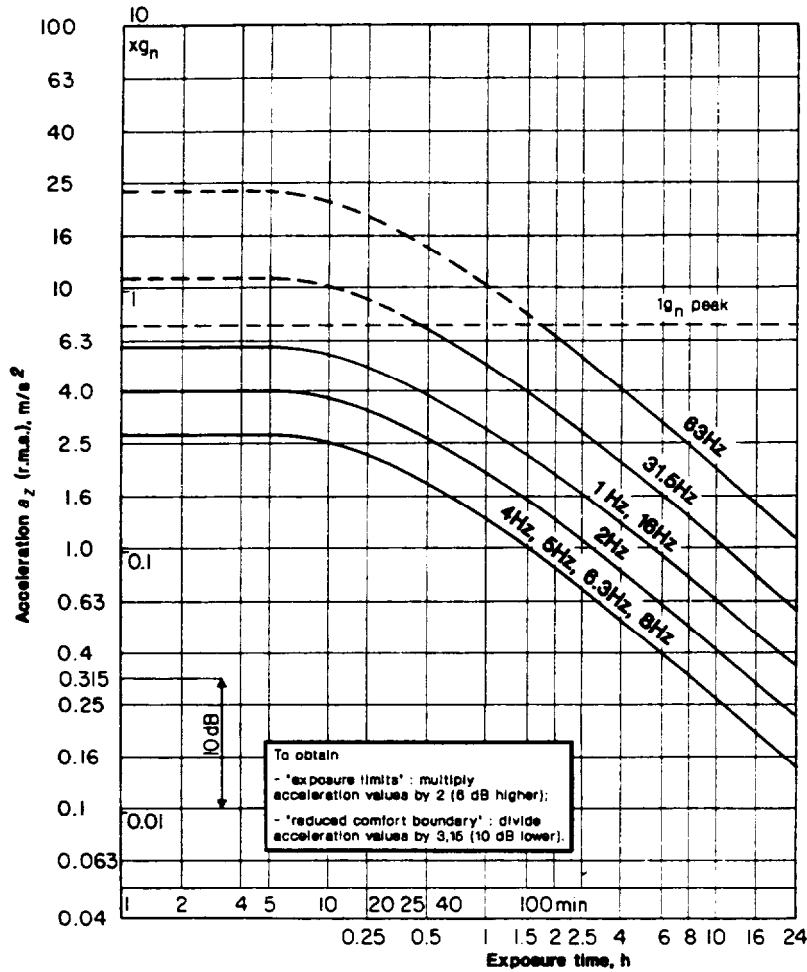

Figure 2-12. Longitudinal (a_x) acceleration limits as a function of exposure time and frequency (centre frequency of one-third octave band); “fatigue-decreased proficiency boundary” (ISO, 1985).

Protection Against Vibration

Protective measures against vibration fall into three general categories: control at the source, control of transmission, and attempts to minimize human effects. Control at the source is primarily a problem of engineering, and it will not be discussed further in this chapter. Control of transmission can be attempted in several ways. The use of high-damping materials in new construction and damping treatments of existing equipment can reduce structural resonance, which in turn, reduces transmission. Isolating the individual from the vehicle by means of resilient seat cushions and the like is another method of reducing transmission. The usefulness of this tech-

Acceleration and Vibration

nique is necessarily limited when dealing with ejection seats. The “dynamic overshoot” of a cushion during ejection could cause an unacceptable increase in the $+G_z$ impact acceleration experienced by the aviator.

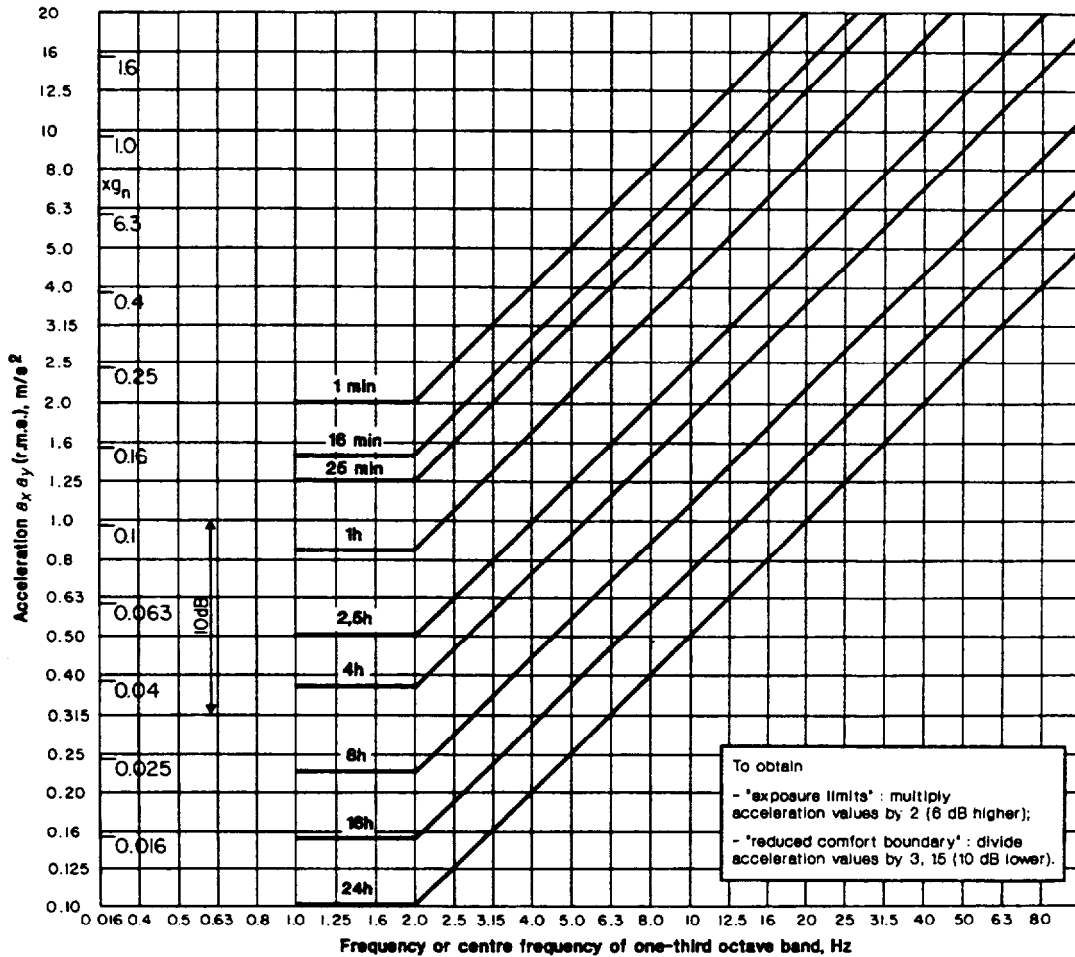

Figure 2-13. Transverse a_x, a_y acceleration limits as a function of frequency and exposure time; “fatigue-decreased proficiency boundary” (ISO, 1985).

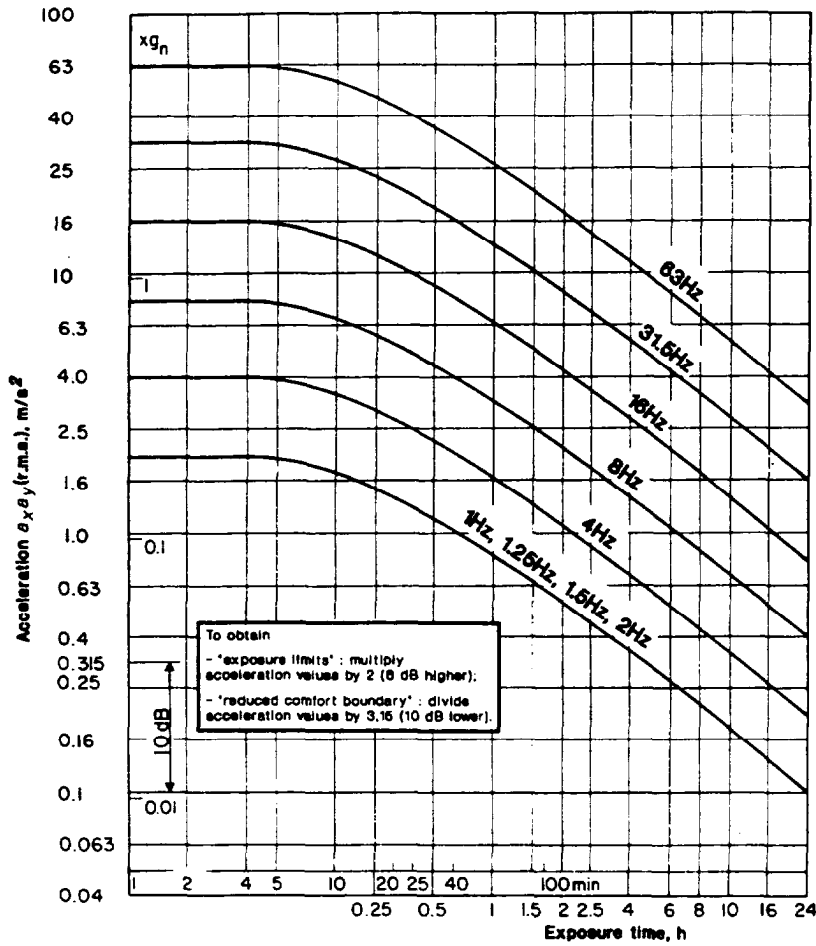

Figure 2-14. Transverse ($a_x a_y$) acceleration as a function of exposure time and frequency (or centre frequency of one-third octave band); "fatigue-decreased proficiency boundary" (ISO, 1985).

The adverse effects of vibration that reach the body can, in some cases, be substantially reduced. Posture can have a great effect. For example, one study of vibration transmission through the trunk to the head showed variations as great as six to one, contingent only on changes in posture (Griffin, 1975). Proper design of displays and flight controls can lead to a cockpit environment that is both more tolerable and more functional during vibration stress. With physical fitness, training, and experience, a considerable amount of adaptation may take place in the aviator. In addition, motion sickness induced by vibration often responds to the standard pharmacological remedies.

References

- Air Standardization Coordinating Committee. Advisory publication 61/103F, methods for assessing visual end points for acceleration tolerance, 1986.
- Antipov, V. V., Davydov, B. I., Verigo, V.V., & Svirezhev, Yu. M. Combined effect of flight factors. In Calvin, M. & Gazenko (Eds.), *Foundations of space biology and medicine*, Vol. II, Book 1. *Ecological and physiological bases of space biology and medicine*. Washington, DC: National Aeronautics and Space Administration, 1975, pp. 639-667.
- Ballo, J. M., & McMeekin, R. R. *Accident reconstruction from analysis of injuries*. Advisory Group for Aerospace Research Development CP-190, 1976.
- Beeding, E. L., Jr., & Mosley, J. D. *Human tolerance to ultra high G forces*. Holloman Air Force Base, NM: Air Force Development Center AFMDC-TN-60-2, Aeromedical Field Laboratory, Air Force Missile Development Center, Holloman Air Force, 1960.
- Burns, J. W., Re-evaluation of a tilt back seat as a means of increasing acceleration tolerance. *Aviation, Space, and Environmental Medicine*, 1975, 46, pp. 55-63.
- Christy, R. L. Effects of radial, angular, and transverse acceleration. In Randel, H.W. (Ed.), *Aerospace Medicine* (2nd ed.). Baltimore, MD: Williams and Wilkins, 1971, p. 187.
- Cohen, M. M. Combining techniques to enhance protection against high sustained accelerative forces. *Aviation, Space, and Environmental Medicine*, 1983 54, 338-342.
- Eiband, A. M. Human tolerance to rapidly applied acceleration: A summary of the literature. National Aeronautics and Space Administration Memorandum 1- 19-59E, June 1959.
- Evaluation of human exposure to whole-body vibration, Part I. General Reents (1st ed.)*. International Standards Organization, ISO 2631/1-1985 (E).
- Gell, C. F. Table of Equivalent for Acceleration Terminology. *Aerospace Medicine*, 1961, 32, 1109.
- Griffin, M. J. Vertical Vibration of Seated Subjects: Effects of Posture, Vibration Level, and Frequency. *Aviation, Space, and Environmental Medicine*, 1975, Vol. 46, 269-276.
- Guyton, A. C. *Textbook of medical physiology* (6th ed.). Philadelphia, PA: W. B. Saunders Company, Philadelphia, PA, 1981, p. 248.
- Haskell, B. S. Association of aircraft noise stress to periodontal disease in aircrew members. *Aviation, Space, and Environmental Medicine*, 1975, 46, 1041-1043.
- Houghton, J. O., McBride, D. K., & Hannah, K. Performance and physiological effects of acceleration-induced (+G_z) loss of consciousness. *Aviation, Space, and Environmental Medicine*, 1985, 56, 956-965.
- Human tolerance to impact conditions as related to motor vehicle design*. Society of Automotive Engineers Information Report SAEJ885, April 1980.
- Johanson, D. C., Flick, V. P., & Terry, D. M. *An in-depth look at the incidence of in-flight loss of consciousness within the U.S. Naval Service: A final report* (Naval Weapons Center Report NWC TT-6737). China Lake, CA: Naval Weapons Center, June 1986, 44 pp.
- Leverett, S. D., Jr., & Whinnery, J. E. Biodynamics: Sustained acceleration, In DeHart, R.L. (Ed.), *Fundamentals of aerospace medicine*, Philadelphia, PA: Lea and Febiger, 1985.
- Lewis, S. Human tolerance to abrupt deceleration. Unpublished notes from the Crash Survival Investigator's School, Arizona State University, Tempe, AZ, 1974.
- Rotondo, G. Spinal injury after ejection in jet pilots: Mechanisms, diagnosis, followup, and prevention.

U.S. Naval Flight Surgeon's Manual

- Aviation, Space, and Environmental Medicine*, 1975, 46, 842-848.
- Stapp, J.P. *Human exposures to linear deceleration, Part 2. The forward facing position and the development of a crash harness* (Air Force Technical Report 5915). Wright Patterson Air Force Base, OH: Aeromedical Laboratory, Wright Air Development Center, 1951.
- Strandness, D. E., Jr. Pain in the extremities. In Wintrob, M.W. (Ed.), *Harrison's principles of internal medicine* (7th ed.). New York, NY: McGraw-Hill, 1974, pp. 44-48.
- Von Gierke, H. E., & Brinkley, J. W. Impact accelerations. In Calvin, M. & Gazenko O. G. (Eds.), *Foundations of space biology and medicine, Vol II, Book, I, Ecological and Physiological bases of space biology and medicine*. Washington, DC: National Aeronautics and Space Administration, 1975, pp. 214-246.
- Von Gierke, H. E., & Clarke, N. P. Effects of vibration and buffeting on man. In Randel, H. W. (Ed.), *Aerospace medicine* (2nd ed.). Baltimore, MD: Williams and Wilkins, 1971, pp. 198-223.
- Von Gierke, H. E., Nixon, C.W., & Guignard, J.C. Noise and vibration. In Calvin, M. and Gazenko, O.G. (Eds.), *Foundations of space biology and medicine. Vol. II. Book I. Ecological and Physiological Bases of Space Biology and Medicine*. Washington DC: National Aeronautics and Space Administration, 1975, pp. 355-405.
- Whinnery, J. E. Laughlin, M.H., & Uhl, G.S. Coincident loss of consciousness and ventricular tachycardia during +G_z stress. *Aviation, Space and Environmental Medicine*, 1980, 51, 827-831.
- Whinnery, J. E. & Shaffstall. R. M. Incapacitation time for +G_z induced loss of consciousness. *Aviation, Space, and Environmental Medicine*, 1979, 50, 83-85.
- Whinnery, J. E. Technique for simulating G induced tunnel vision. *Aviation, Space and Environmental Medicine*, 1979, 50, 1076.
- Williams, N. Biological effects of segmental vibration. *Journal of Occupational Medicine*, 1975, 17, 37-39.
- Wasserman, D. Bumps, grinds take toll on bones, muscles, mind. *Occupational Health and Safety*, 1976, 45, 19-21.

CHAPTER 3

VESTIBULAR FUNCTION

Introduction

Structure and Function of the Vestibular System

Spatial Disorientation

Visual-Vestibular Interactions Relevant to Aviator Vision

Vestibular Contributions to Disorientation

Disorientation Not Attributable to Strong Vestibular Stimuli Primacy of Vision

Prevention of Disorientation

Evaluation and Management of Disorientation Problems

References

Introduction

Vestibular problems sometimes encountered by flight personnel in aviation and aerospace missions are very similar to symptoms reported by patients with vestibular disorders of sudden onset. Disorientation (vertigo, dizziness, tumbling sensations), nausea, and vomiting, episodes of blurred and unstable vision, and impaired motor control (disequilibrium) are effects which can occur singly and in various combinations as a result of either exceptional environmental stimuli or episodic vestibular disorders or both. In the aviation environment, the symptoms may be normal reactions to misleading or inadequate sensory stimuli, but they may be coupled with requirements for controlling a high performance aircraft in three-dimensional space. In pathological states, the symptoms result from disordered transduction of central processing of head accelerations, and this is likely to be coupled with requirements for control of head and body motion. In either case, the origin of the aberrant reactions lies in inadequate or misleading information about the state of motion or orientation of the body relative to Earth, and ultimately this constitutes a threat to survival. It is natural, then, that unexpected occurrences of such reactions can be very disturbing. The parallel between pathological states and exceptional environmental conditions can be taken farther. When unnatural motion conditions are frequently experienced, a state of adaptation is frequently achieved in which the disturbance and disequilibrium initially elicited, gradually abate; perceptual aberrations disappear, and control of motion approaches a desirable state of automaticity. A similar process occurs in disease states. Disordered sensory inputs are compensated by central adaptive processes. As a matter of fact, the adaptive process sometimes keeps

pace with a very gradual loss of function, such that no symptoms are experienced. Attention to this parallel is of probable practical importance to both the civilian practitioner and the specialist in aviation medicine. An understanding of the perceptual aberrations and reflexive actions generated by unusual motion stimuli and the process of adaptation to those stimuli may increase our understanding of the symptomatology generated by various disease states, and of course, the converse is also true.

Structure and Function of the Vestibular System

The vestibular system, almost like sensors in an inertial guidance system, detects static tilt of the head relative to the Earth, change in orientation of the head relative to the Earth, and linear and angular accelerations of the head relative to the Earth. These sensory messages are set off early in life by passive, involuntary movement, and they probably play an important role in development (Guedry & Correia, 1978; Ornitz, 1970). Not long thereafter, however, vestibular messages are frequently elicited by active, voluntary movement, and then they play a role in development of skill in the control of whole-body movement. In ambulatory man, the head is the uppermost motion platform of the body, and to be functional, vestibular messages must be integrated with proprioceptive and visual inputs. Vestibular messages coordinate with these other sensory systems in setting off reactions that reflexively adjust the head, eyes, and body for automatic control of motion.

In this chapter, it is assumed that the reader is familiar with the basic anatomy and structure of the vestibular system. However, as a reminder, some basic information about this system will be presented along with a nomenclature convenient for describing stimuli to the vestibular structure. Figure 3-1 illustrates anatomical features of the semicircular canals and of the utricle and saccule. The major planes of the semicircular canal ducts relative to the cardinal head axes are shown in the insets. A gelatinous cupula protrudes into the ampulla of each semicircular duct and serves as a sensory detector of angular accelerations in its plane. Gelatinous pads, one in the utricle and one in the saccule, have calcite crystals imbedded in their surfaces and are sensory detectors of linear accelerations of the head. Note the acute angle of the small ducts connecting utricle and saccule. With saccular destruction, the small duct to the utricle may close, possibly preserving the functional integrity of the utricle and semicircular canals. This possibility is speculative, but it may account for early experimental results indicating lesser equilibration disturbance after saccular as compared with utricular ablation. Utricular ablation would destroy the integrity of both the semicircular canals and utricle.

Stimuli to the Vestibular System

The vestibular apparatus consists of two distinctive kinds of sense organs: (1) the cupulae in the ampullae of the semicircular canals respond to angular accelerations that occur as head turns start and stop; (2) the otolithic sense organs in the utricle and saccule respond to linear accelerations of the head or to tilting of the head relative to gravity.

Each semicircular canal is stimulated by angular acceleration α in its plane. If there is an angle β , between the plane of the canal and the plane of the angular acceleration of the head, then the effective stimulus to the canal, α_e , is given by $\alpha_e = \alpha \cos \beta$. This means that if the horizontal canals lie in the plane of α , stimulation of the two vertical canals would be zero since $\cos 90^\circ = 0$.

Angular acceleration is independent of the distance from the center of rotation, and the semicircular canals are not responsive to linear accelerations, probably due to the close similarity in specific gravity of the cupula and the endolymph. Recently it has been suggested that substantial contact between the cupula and the interior membranous ampullary wall, all around the periphery of the cupula, would limit deflection of the cupula to its central portion, like the movement of a drum. If correct, this could further reduce responsiveness to this system to linear acceleration. Therefore, a person seated with head erect at the center of rotation of a vehicle undergoing angular acceleration would receive the same stimulus to the semicircular canals as another person seated with head erect five meters, or farther from the center of rotation. The latter would, of course, be exposed to much greater centripetal and tangential linear acceleration, and hence a different otolith stimulus than the former, but the stimulus to the semicircular canals would be theoretically identical.

Analysis of the inertial forces and torques which displace the utricular and ampullar sense organs involves a branch of physics referred to as kinetics, but these forces and torques are proportional to linear and angular accelerations of the head. Therefore, the commonly used kinematic descriptions of linear and angular accelerations of the head are sufficient for specifying vestibular stimuli.

Linear acceleration is the rate of change of linear velocity, and it can be expressed in cm/sec^2 , m/sec^2 , ft/sec^2 , or G-units. Acceleration is expressed in G-units when it is given in multiples of $32.2 \text{ ft}/\text{sec}^2$ (i.e., in multiples of the acceleration that Earth's gravity imparts to a freely falling body). When linear acceleration is represented as a vector, the arrowhead points in the direction of acceleration and its length represents its magnitude, but in order to be physiologically meaningful, it must be "man-referenced." A convenient nomenclature for this purpose is presented in Figure 3-2.

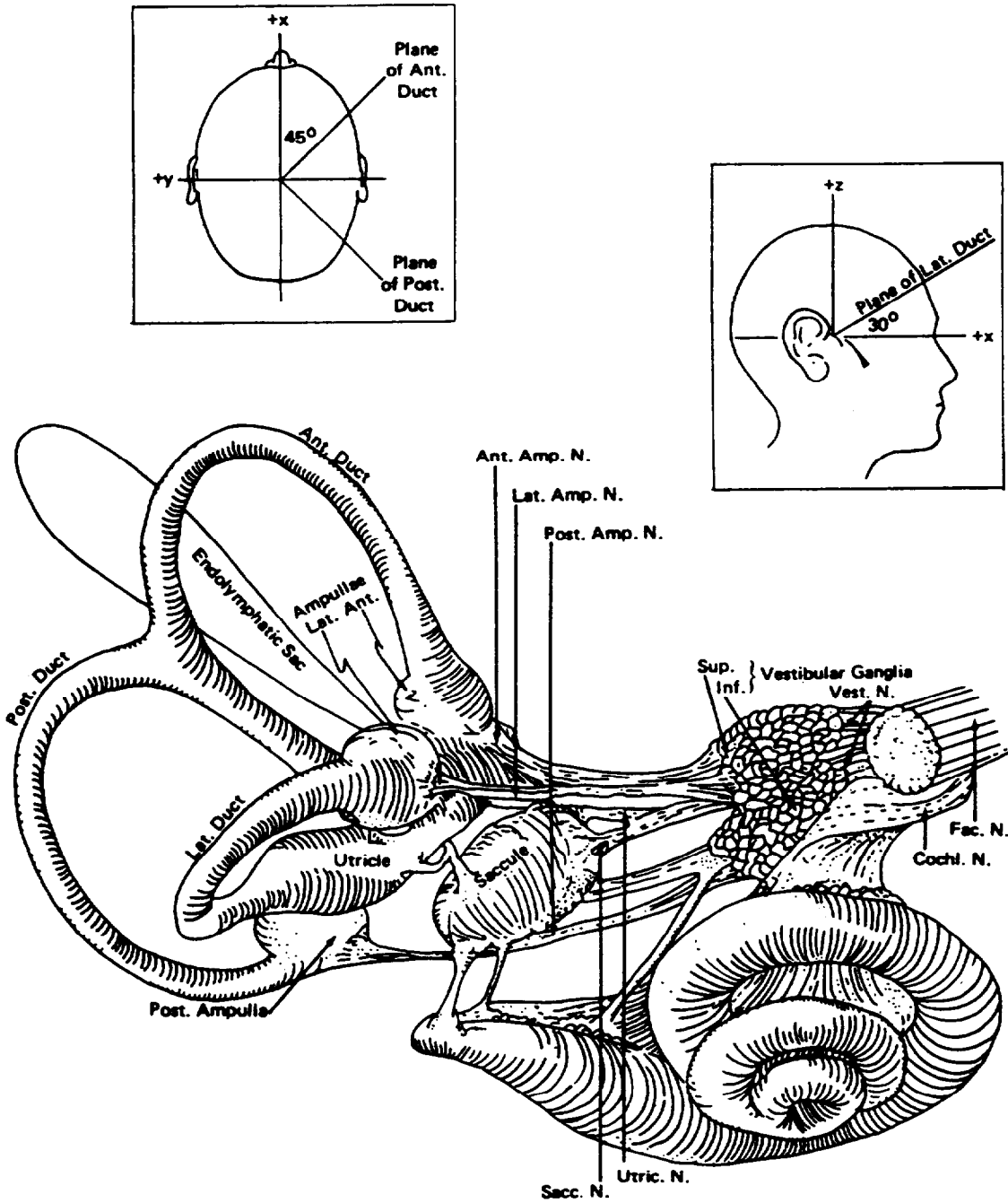

Figure 3-1. Gross morphology of the membranous labyrinth and cochlea (adapted from Correia & Guedry, 1978).

Vestibular Function

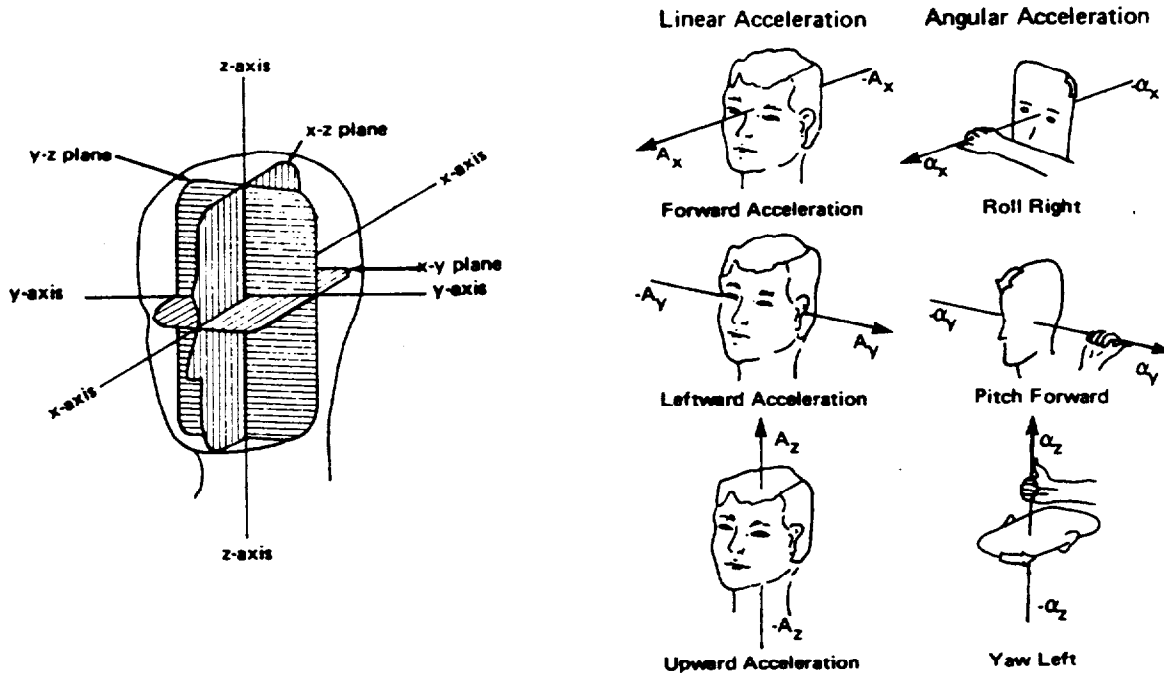

Figure 3-2. Polarity conventions, planes, and cardinal axes of the head. Linear and angular accelerations are vectors that must be specified in relation to anatomical coordinates of the head in order to be properly described as vestibular stimuli. These head axes, as defined by Hixson, Niven, and Correia (1966), provide a clear anatomical reference to which stimulus parameters can be related. Relations between this and the nomenclature used in Chapter 2 are clarified in Figure 3-6.

Polarity conventions, planes, and cardinal axes of the head. Linear and angular accelerations are vectors that must be specified in relation to anatomical coordinates of the head in order to be properly described as vestibular stimuli. These head axes, as defined in Hixson, Niven and Correia (1966), provide a clear anatomical reference to which stimulus parameters can be related. Relations between this and the nomenclature used in Chapter 2 are clarified in Figure 3-6.

Angular acceleration (α) is the rate of change of angular velocity (ω), and it can be expressed in any angular unit like deg./sec.^2 or rad./sec.^2 . However, the radian (rad.) must be used in formula for calculating instantaneous linear measures from angular measures when the radius is known. Angular acceleration can also be represented as a vector, as illustrated in Figure 3-2. The angular acceleration vector must be drawn in alignment with (or parallel to) the axis of rotation, and its arrowhead end is determined by following the right-hand rule: When angular velocity is increas-

ing, point the curled fingers of the right hand in the direction of rotation, and when angular velocity is decreasing, point the curled fingers opposite the direction of rotation; in each case, the thumb determines the direction of the arrowhead. Since the α vector is perpendicular to the plane of rotation, a simple way to envision its effectiveness in stimulating a semicircular canal is to imagine that the canal has an axis. If the vector and canal axis are aligned, then α would be maximally effective in stimulating the canal. The angle between the canal axis and the angular acceleration vector is the same as the angle β mentioned in a preceding paragraph. Thus, α_z (Figure 3-2) would stimulate the lateral (or horizontal) canals and not the vertical canals.

Sensory Transduction of Head Motion into Coded Neural Messages

There is a spontaneous activity in the vestibular nerve. If the head starts to turn left about the z-axis ($+\alpha_z$), the rings of endolymph in the two lateral (horizontal) canals tend to lag behind due to inertia, thereby deflecting the cupula, as illustrated in Figure 3-3. In the lateral canals, deflection of the cupula toward the utricle (utriclepetal deflection) increases the rate of firing of the left ampullary nerve, while deflection away from the utricle (utriclefugal deflection) in the right lateral canal decreases the firing rate. Therefore, for this particular head movement, the two lateral canals provide a synergistic push-pull input (increased discharge from the left and decreased from the right) to the central nervous system (CNS), while neural input from the two vertical canals, being at right angles to the plane of angular acceleration, remains at spontaneous level. In the vertical canals (the anterior and posterior canals), utriclefugal cupula deflection increases firing rate, while utriclepetal deflection decreases it. Thus, for each different plane of angular acceleration of the head, the canals provide a unique pattern of sensory inputs which can be "interpreted" by the CNS so that compensatory reactions in the appropriate plane are produced. Note that the ability of each canal to increase or decrease the rate of discharge of its ampullary nerve has important functional significance. It means that a single canal is capable of signaling rotation in either direction in its plane. Also a single intact inner ear, due to the orthogonal arrangement of the three semicircular canals in each ear, is capable of signaling direction of rotation in any plane of head rotation. Figure 3-3 is also convenient for visualizing expected initial reactions to peripheral vestibular disorders.

The otolithic sensory organs in the utricle and saccule respond to linear acceleration and to tilts of the head relative to gravity (Figure 3-4). Calcite crystals at the surface of the gelatinous plaques that comprise the utricular and saccular sense organs have a specific gravity of 2.71, much greater than that of the surrounding medium, and this property is responsible for these organs acting as density-difference, linear accelerometers. The surface of the utricular otolith membrane is slightly curved, but its plane is approximately parallel to that of the lateral semicircular canals. Linear acceleration, acting parallel to the plane of the otolith membrane (frequently referred to as the

Vestibular Function

“shear” direction), is considered the effective stimulus to this sensory system (Fernandez, Goldberg & Abend, 1972). Therefore, a rightward, linear acceleration of 245 cm/sec.^2 (equivalent to .25G) would produce a leftward shifting or sliding of the otolith membrane (relative to underlying hair cells (Figure 3-4B)) that would be equal to that produced by tilting the head 15 degrees to the left (Figure 3-4C) because the “shearing” component of the stimulus would be equal in both situations. *Actually*, a sustained rightward linear acceleration of 245 cm/set.^2 is perceived as a leftward tilt of approximately 15 degrees. As in the ampullary nerves, there is spontaneous firing of the utricular and saccular nerves.

The hair cells at the base of the utricle are shown diagrammatically in Figure 3-4. Hairs projecting upward from each cell have a morphological polarization determined by the position of one lone distinctive kinocilium relative to rows of stereocilia diminishing in length row by row with distance from the kinocilium (Lindeman, 1969). It has been found that deflection of the hair bundles toward the kinocilium increases the neural discharge rate, whereas opposite deflection decreases the discharge rate relative to the spontaneous level. All cells “point” toward a hook-shaped striola that curves through the macular utriculi, and a similar arrangement exists in the saccule. It is also the morphological polarization of hair cells in the cristae of the semicircular canals that determines which direction of cupula deflection increases the neural firing rate. Therefore, direction of tilt of the head is signaled by different topographical patterns of discharge in the utricular nerve. For example, if the head were tilted forward, the cells depicted in Figure 3-4 would be relatively unaffected, that is, the spontaneous firing rate would be approximately maintained, but neural activity triggered by other cells in other locations within the macula would be changed significantly. *Amount* of tilt in a *given* direction would be signaled by the amount of change of a specific *unique pattern* for that direction of tilt relative to the spontaneous firing level.

The otolithic receptors have both static and dynamic functions (Fernandez & Goldberg, 1976; Goldberg & Fernandez, 1975) that is, in addition to signaling static position of the head relative to gravity, some nerve fibers from the utricle and saccule respond to change in position. These latter units respond when the otolith membrane is moving relative to the underlying hair cells, thus they respond to change in linear acceleration. This ability of the otolithic receptors to supply both position and change-in-position information will be discussed below in terms of their potential contributions to spatial orientation. Neurophysiological studies also indicate that with sustained tilt, there is some evidence of adaptation in some “position-sensitive” units.

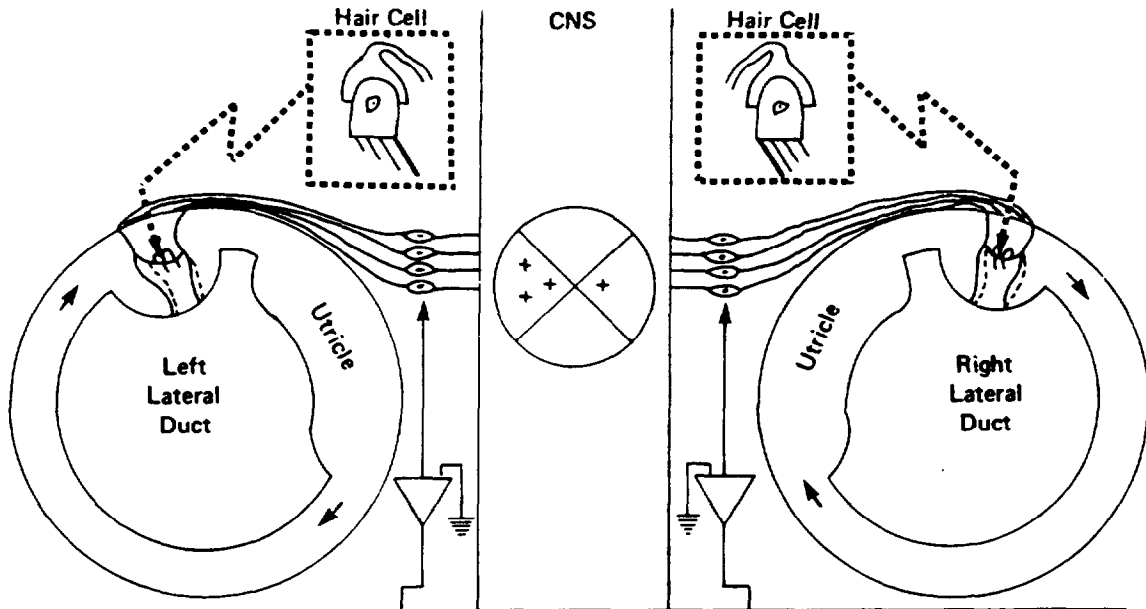

Condition	Discharge Pattern	Comparator Condition	Discharge Pattern
Head Stationary	[Regular rhythmic discharge]	[Crossed circle with 4 '+' signs]	[Regular rhythmic discharge]
Head Left	[High frequency discharge]	[Crossed circle with 3 '+' signs]	[Low frequency discharge]
Left Ear Hyperact.	[High frequency discharge]	[Crossed circle with 4 '+' signs]	[Regular rhythmic discharge]
Left Ear Hypoact.	[Low frequency discharge]	[Crossed circle with 2 '+' signs]	[Regular rhythmic discharge]

Figure 3-3. Direction of endolymph displacement (arrows in the lateral semicircular canals) during angular acceleration of the head to the left (counterclockwise as viewed from above). Dashed lines indicate cupula displacement which deflects hairs projecting into cupula. The inset hair cell illustrates stereocilia relative to the kinocilium (dark hair). Deflection of the hair bundle toward the kinocilium increases neural discharge, while deflection away from the kinocilium decreases neural discharge relative to spontaneous level. Irritative and ablative insults which result in similar CNS comparator states tend to produce similar sensations and reflex actions (Correia & Guedry, 1978).

Vestibular Function

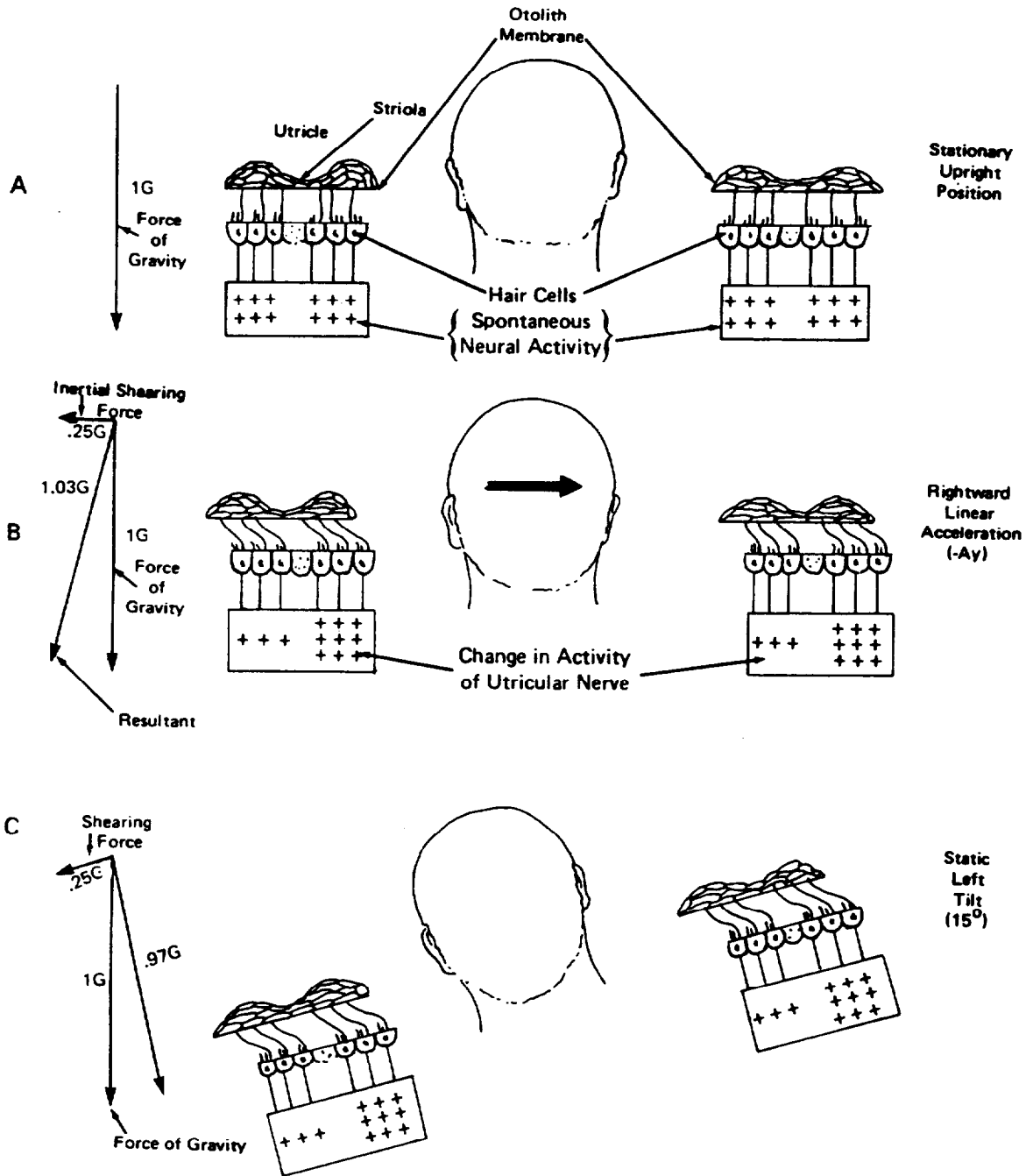

Figure 3-4. Spontaneous neural discharge from utricular nerve and its modulation under various conditions.

Acceleration Principles and Nomenclature

Einstein's Equivalence Principle and Spatial Orientation. In dealing with linear acceleration, it is important to recognize the equivalence of the effects of linear acceleration and gravity. Einstein's equivalence principle states that a gravitational field of force at any point in space is in every way equivalent to an artificial field of force resulting from linear acceleration. In Figure 3-4B, the reaction to linear acceleration was resolved with the effect of gravity to yield a resultant vector of 1.03 G. Assuming that this condition is sustained, a person experiencing it might be expected to feel tilted about 15 degrees because he is tilted 15 degrees relative to the existing force field.

Also, according to Einstein, space is isotropic, that is, vertical is not a special dimension, it only seems that way because of man's limited view of the universe. However, we are dealing with man, whose perceptions develop from a very limited view early in life and expand somewhat with experience, yet, many effects of ontogenetic and phylogenetic development remain. Moreover, in the practical business of landing an aircraft or even walking on Earth, the vertical is a special dimension which must be accurately estimated one way or another. From the point of view of understanding spatial orientation, it is important to recognize the equivalence of linear acceleration and gravity while remembering that man usually operates as though the vertical and horizontal are special dimensions. Thus, when a linear acceleration and gravity are vectorially resolved to give a new direction to the acceleration field, this new direction may be accepted by the man as vertical, depending upon his perceptual and intellectual assessment of how his position was attained. Pilots learn that the resultant of gravity and an accelerative force in flight can seem to be vertical when it is "tilted" relative to Earth.

An Example of the Use of Acceleration Nomenclature. Consider a pilot (Figure 3-5) in an aircraft that increases speed at a constant rate for ten seconds in going from 440 mph to 500 mph during level flight (i.e., a speed change of 60 mph). The aircraft imparts a linear acceleration to the pilot along his x-axis, and it has a magnitude of 8.8 ft./sec². By the nomenclature, the sign of this acceleration relative to the man is defined as positive, and the magnitude is indicated by the length of the vector, which would be 8.8/32.2 or 0.27 of the length of the arrow designating the magnitude of gravity. Thus the linear accelerations, expressed in G-units, along the head axes are $A_x = + .27$ g, $A_y = 0$, and $A_z = + 1$ g.

Now consider the flight engineer in Figure 3-5 seated facing an instrument display on one side of the aircraft. While the aircraft is accelerating, his linear acceleration can be described by $A_x = 0$, $A_y = -.27$ g, and $A_z = + 1$ g. The resultant has moved from his z-axis toward his y-axis; it has rotated in the y-z plane about the x-axis as shown in Figure 3-5. The resultant vector, A_{yz} ,

Vestibular Function

makes an angle $+ \phi_x = 15.3$ degrees, with the engineer's z-axis. (The positive sign of the angular displacement, ϕ_x , can also be established by the right-hand rule of rotation. When the thumb of the right hand is pointed along the + x head axis, the curled fingers point in the direction of rotation.) The two men receive the same acceleration, but the physiological effects are different because the men are oriented differently in the aircraft. If the direction of the resultant acceleration in Figure 3-5 (A_{xz} for the pilot and A_{yz} for the flight engineer) is accepted as upright, the pilot will perceive a backward tilt and the flight engineer will perceive a leftward tilt. However, both would be likely to perceive a nose-up attitude of the aircraft, assuming that each is aware of his orientation relative to the aircraft.

Representation of the Direction of Gravity. In Figure 3-4, the vector (G) representing gravity is a downward-directed arrow, whereas in Figure 3-5 it is an upward-directed arrow (g). This inconsistency was purposely introduced to illustrate that there is some variation in aerospace medicine in regard to the directional representation of force vectors. There is a choice as to which of the following shall be represented -- (1) the action of a force on the body, or (2) the reaction of the body to the force.

When an aircraft in level flight increases forward speed, vectorial representation of the acceleration and of the force applied to the pilot by the back of the seat would be forward, as illustrated in Figure 3-6A. The body reacts to this force by an equal and opposite backward-directed (inertial) force (Figure 3-6B), and since the body is not rigid and is not of uniform density, some organs within the body will be displaced slightly backward relative to the skeletal system. Likewise, the seat is applying an upward-directed force, equal and opposite to the weight of the man on it. However, the effect of gravitational attraction is to displace organs downward relative to the skeletal system, just as though the man were being accelerated upward. If actions of the seat on the man are represented, that is, if the forward acceleration is represented by a vector pointing forward, then gravity must be represented by an upward-directed vector as in Figure 3-6A. If reactions are represented, that is, direction of displacement of body organs relative to skeletal system, then the x-axis vector must point backward and the gravity vector downward as in Figure 3-6B. Note that the length and *line-of-action* of resultant vectors (heavy black arrows) are the same in Figures 3-6A and B, whereas the resultant line-of-action represented in Figure 3-6C is *incorrect* because a mixture of action and reaction vectors has been used.

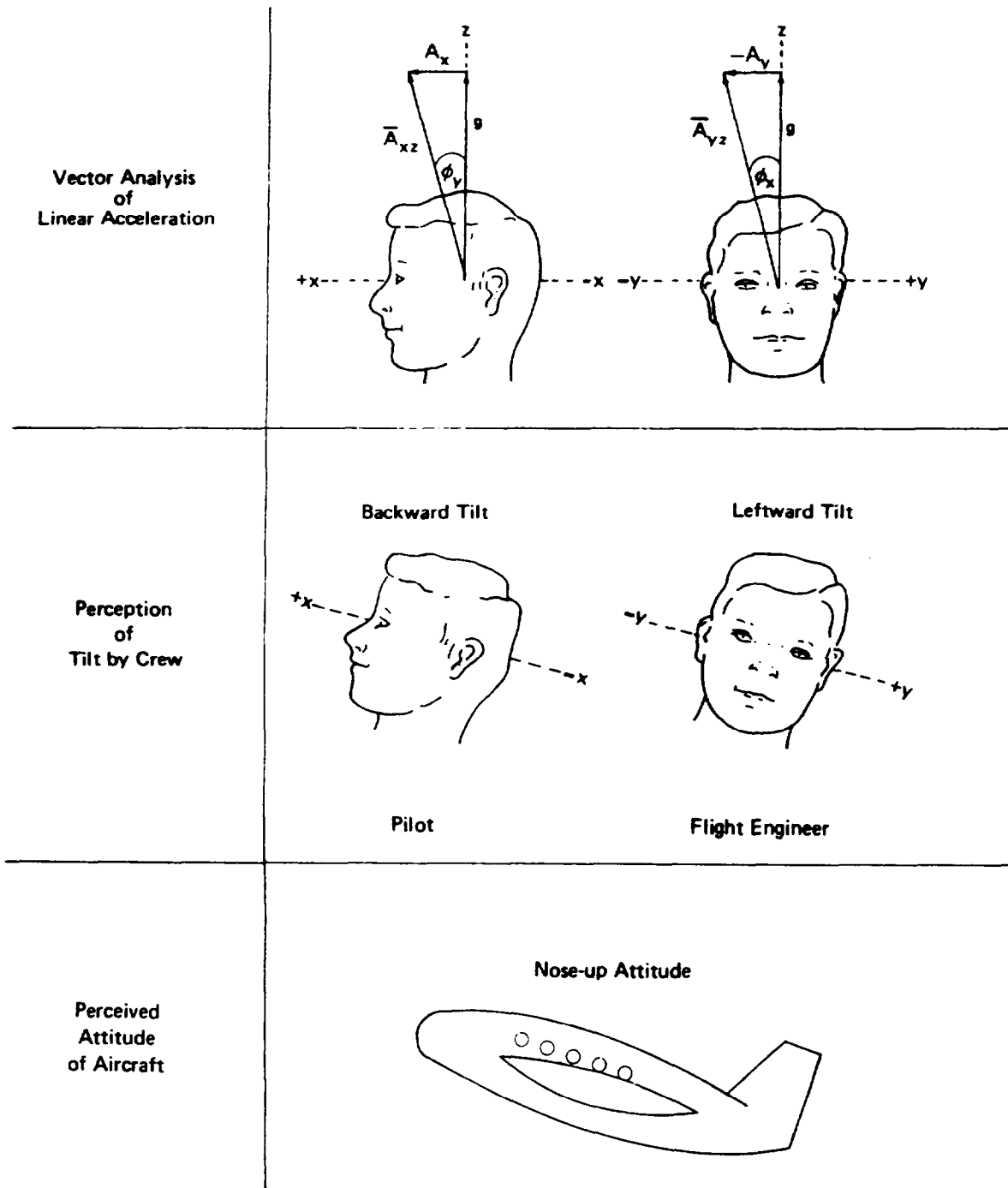

Figure 3-5. Different perceptions of tilt in a pilot and flight engineer in an aircraft accelerating during level flight. The resultant of the linear acceleration and gravity rotates toward the x- axis in the pilot and toward the y-axis in the flight engineer.

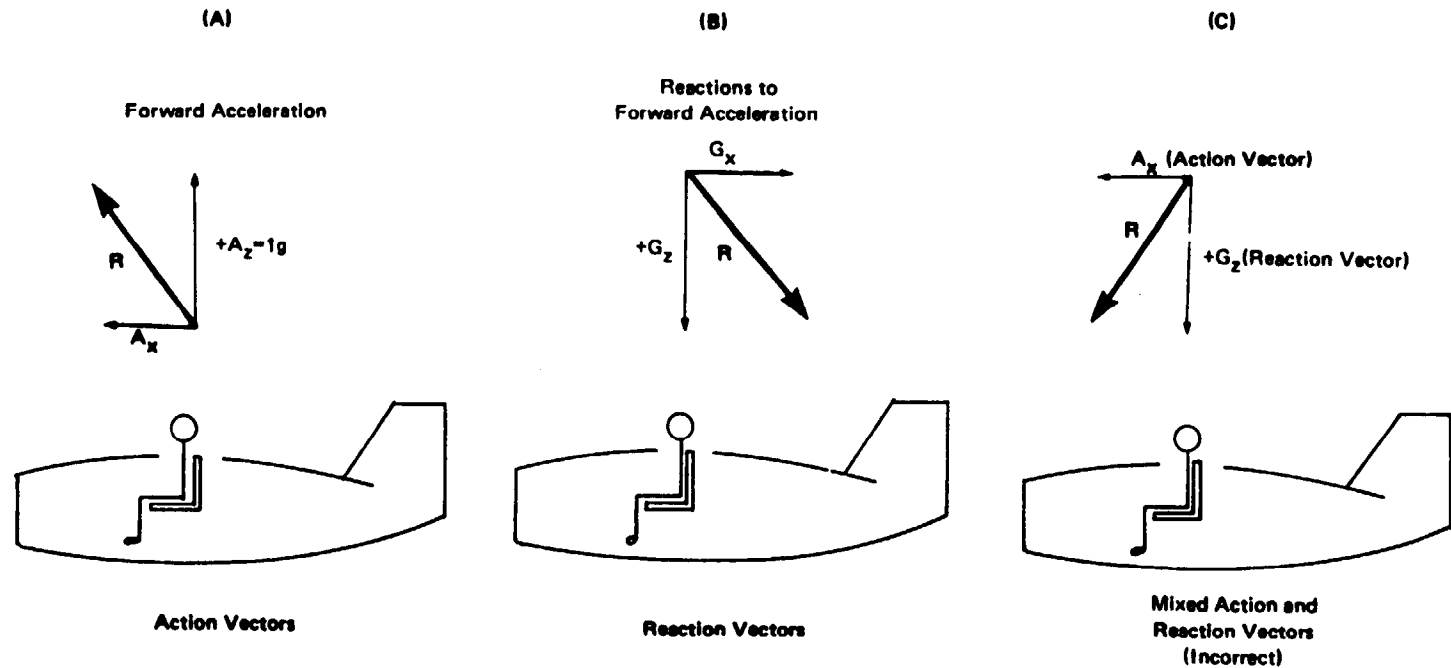

Figure 3-6. The directional representation of action and reaction vectors. The line of action of the resultant vector is incorrect in (C). In aviation medicine, reaction vectors are frequently used, and gravity is often symbolized by G and a downward-directed vector. For man-referenced reaction vectors, $+G_z$ is usually defined as the head-to-seat direction (see Chapter 2), whereas for action vectors as defined by Figure 3-2, $+A_z$ is defined as the seat-to-head direction.

Coding of Vestibular Messages.

In the aerospace environment, unusual linear and angular accelerations occur frequently. The occurrence of a single, exceptional linear or angular acceleration component can induce disorientation or vertigo, but more typically, one must consider combinations of stimuli to appreciate troublesome situations. To comprehend the functional significance of unusual stimuli combinations, it is helpful first to appreciate the coding of normal vestibular messages that occur in natural movement (i.e., movement not involving vehicular transport). In natural movement, whenever the head is tilted away from upright posture, the semicircular canals and otoliths *always* provide *concomitant, synergistic* messages. For example, during backward head tilting from upright posture, change in neural activity from the four vertical canals and absence of change from the two horizontal canals is a coded message to the CNS signifying angular velocity of the head about its **y-axis, $-\omega_y$** . Concomitantly, changes in neural activity would be generated by the otolithic receptors. During the head tilt, the utricular otoliths would slide backward, triggering change-in-position receptors as well as position receptors in a pattern signifying a position change about the y-axis, and the final coded utricular position information would be predictable from the preceding change-in-position information. Likewise, it has been shown that integration of the angular velocity information from the semicircular canals can be subjectively performed to obtain an angular displacement estimate equal to the position change which has occurred (Guedry, 1974,50-56), and hence, equal to that signaled by the otoliths. When the head is turned about an axis that is aligned with gravity (for example, the head turns about the z-axis in upright posture or about the y-axis while lying on one side), the semicircular canals are stimulated, but there is no change in orientation of the otolith system relative to gravity, and hence, no change-in-position information from the otolith system. Under this circumstance, that is, when the axis of rotation signaled by the semicircular canals is aligned with the gravity vector as located by the otolith system, these two classes of vestibular receptors do not reinforce one another, but it should be noted that there is no conflict in their information content.

Consider now the situation depicted in Figure 3-5. During forward acceleration of the aircraft, the resultant linear acceleration, A_{xz} , rotates from alignment with the pilot's z-axis forward toward his x-axis through an angle designated as **$+\phi_y$** . As was pointed out earlier, this is the same change relative to the existing force field that would occur if head and body were simply tilted backward relative to gravity 15 degrees. However, *during* the "tilting" process, the vestibular message would be quite different in these two situations. In the latter situation (real tilt), the synergistic messages from the semicircular canals and the otolithic receptors as described above would be present. Degree of backward tilt would be quickly and accurately perceived. During the dynamic phase of the stimulus in the former situation (forward acceleration), change-in-position and position information from the otolithic receptors would be unaccompanied by synergistic information from the semicircular canals. "Tilt" relative to the resultant, A_{xz} , would be greatly

Vestibular Function

underestimated or not perceived at all (cf., Guedry, 1974, p. 106-108); rather, the individual would perceive forward linear velocity (i.e., he would perceive what is actually happening). However, if the forward linear acceleration is sustained for a while, then, in this “steady state” condition, the otolithic position input would signal tilt, and, as in static tilt relative to gravity, otolithic or semicircular canal change-in-position information would be absent. In this case the individual would experience backward tilt as though he were tilted relative to gravity, but only after a delay or lag. Each of the conditions just described, except sustained horizontal linear acceleration, occurs in natural movement, and each produces a pattern of vestibular input that is familiar and perceived quickly and accurately if the observer chooses to attend to it. In subsequent sections of this chapter, conditions of motion will be described that produce conflicting vestibular inputs, and these are usually confusing, disturbing, disorienting, and nauseogenic.

In partial summary, the semicircular canals localize the angular acceleration vector relative to the head during head movement and contribute the sensory input for (1) appropriate reflex action relative to an anatomical axis and (2) for perception of angular velocity about this axis. Perception of how this axis is oriented relative to the Earth depends upon sensory inputs from the otolith and somatosensory systems, and thus, appropriate reflex actions relative to the Earth depend upon these other systems working synergistically with the semicircular canals. The otoliths provide both static and dynamic orientation information (relative to gravity) and contribute to the perception of tilt and also to the perception of linear velocity. The perception of linear velocity derives from a *combination* of (1) change-in-position information from the otoliths and (2) the absence of angular velocity information from the canals. The otoliths provide change-in-position information when the cilia are in motion, and the stimulus required is change in linear acceleration.

Spatial Disorientation

in an aviator, spatial disorientation usually refers to the inaccurate perception of the attitude or motion of his aircraft relative to the coordinate system constituted by the Earth’s surface and gravitational vertical, and it can endanger flight safety. Spatial disorientation has been estimated to account for between four and ten percent of major military aircraft accidents and even higher percentages of fatal accidents (Gillingham & Krutz, 1974, p. 66; Hixson & Spezia, 1977). From 1977-1981, disorientation was a direct or contributing cause of 31 percent of pilot-error accidents in the U.S. Navy, and in the U.S. Airforce (from 1980-1985) the figure was 34 percent. In private civilian aviation in the U.S. from 1964 to 1972, disorientation and closely related categories accounted for 37 percent of all fatal accidents (Benson, 1974b).

Disorientation is a normal reaction in many conditions of flight, and it is probably experienced by all pilots at one time or another. Common experiences with disorientation are listed in Table

3-1. It illustrates that there are similarities in disorientation encountered in different types of aircraft and also across a span of 14 years (Clark, 1971). Table 3-2 lists some common disorientation incidents in U.S. Navy helicopter operations (Tormes & Guedry, 1975).

The implications of disorientation incidents range from fatal accidents to inconsequential events that may be instructive to the pilot. Between these extremes are nonfatal accidents, aborted missions, mission degradation, and mission completion but with persisting unfavorable effects on the pilot. A number of factors combine to determine the consequences of a disorientation incident. Clearly one factor is when and where the incident occurs. Sufficient altitude with no other plane or object nearby can provide abundant recovery time and reduce risk, and conversely, proximity to the Earth's surface or other aircraft increases risk. This factor and its relation to items in Tables 3-1 and 3-2 are obvious and will not be elaborated here, but it is a factor that predominates and influences all others. A pilot may be considerably disoriented, but he may be unaware of it. His control actions, based upon perceptual misinformation will place him at risk. When the action is taken, the response of the aircraft may prompt an instrument check which ordinarily will lead to proper corrective action. An important exception occurs when the conflict between an immediate false perception of aircraft orientation and instrument information provokes an excessive emotional reaction; then the pilot remains at risk. Most importantly, the pilot may remain unaware of his disorientation until it is too late for corrective action. In formation flight the pilot's attention is focused on another aircraft, and the perceived aircraft altitude often differs drastically from true altitude because the pilot has been concentrating on maintaining position relative to the other aircraft. Severe disorientation revealed by shift of attention to flight instruments delays appropriate corrective action beyond the point of no return due to proximity of other aircraft or the ground.

Table 3-1

Percentage of Pilots Reporting Disorientation in Current Aircraft Compared
with the Percentage of Pilots Reporting in 1956

Disorientation Incident	Percentages for Various Aircraft Types and Situations					Date from 1956	
	Transport N=65	Training N=105	High Altitude N=39	Single Place Jets N=13	Helicopter N=99	N=137	
Aircraft Attitude Error	Sensation that one wing was down (wings actually level)	71	67	41	85	52	67
	Felt straight and level, but in reality in a turn	40	40	44	46	34	66
	When leveling off after bank, tendency to overbank in opposite direction	42	40	46	92	44	67
	During instrument flight, leaned to right in cockpit to keep self vertical	29	36	31	46	29	45
	During straight and level, felt in a bank	60	56	59	85	42	75
	After steep, climbing turn, felt turn in opposite direction, but instruments indicated straight and level	32	26	23	46	31	55
Visual Reference Problem	Coming out of thick overcast, seemed horizon was severely tilted, though was actually straight and level	25	19	38	46	9	20
	Flare on dark night seemed to move on erratic course, but in reality, it was floating straight down	18	15	3	31	33	23
	Confused on dark night about stars and surface lights; resulted in uncertainty about position of horizon	48	30	49	92	29	--
Flicker	Sunlight through propellers caused flicker; crew member became confused and very uncomfortable	14	10	3	0	26	--
	Flying through fog, became confused by rotating beacon on aircraft causing flickering light in cockpit	42	23	28	46	22	--
Geographic Disorientation	Although in complete control of plane, lost sense of direction; thought flying east, when actually flying north	23	51	28	54	53	47
	On routine patrol flight, had feeling of not knowing location and momentarily turned around in direction	34	43	26	38	45	39
	Had full view of bay with lights around it; seemed like totally strange place, though usually quite familiar	23	25	15	31	34	27

Table 3-1

(Continued) Percentage of Pilots Reporting Disorientation in Current Aircraft Compared with the Percentage of Pilots Reporting in 1956

Disorientation Incident		Percentages for Various Aircraft Types and Situations					Data from 1956
		Transport N=65	Training N=105	High Altitude N=39	Single Place Jets N=13	Helicopter N=99	N=137
Pressure Vertigo	Following loss of altitude while maintaining constant heading, ears cleared, and felt to be in a turn	9	12	10	8	3	--
	Following climb on constant heading, felt bank when straight and level (possible pressure vertigo)	26	29	18	15	21	--
Restricted Instrument Scan	Very intent on target and didn't check altimeter. Suddenly realized was too low, abruptly pulled out with only few feet to spare	14	11	3	23	15	12
	Became confused in attempting to mix contact and instrument cues for orientation	37	31	44	38	31	31
Break-off	Climbing to high altitude, had feeling of isolation and of being separated from earth	23	22	15	38	24	33
Crosswind	On crosswind landing, noticed drifting badly across runway, but failed to make any correction	15	22	8	0	8	12

Vestibular Function

Table 3-2

Survey of helicopter Pilot Disorientation Experiences

Described Circumstance	Percentage of 104 Pilots Reporting Disorientation
Sensation of not being straight and level after bank and turn ("the leans")	91
Low altitude hover over water, night	81
Reflection of anti-collision light on clouds and fog outside the cockpit	70
Transitioning from IFR to VFR and vice versa	62
Misinterpretation of relative position or movement of ship during night approach	58
Head movement while in bank or turn	56
Landing on carrier or other aviation ship, night	51
Night transition from hover over flight deck to forward flight	49
Misperception of true horizon due to sloping cloud bank	47
Inability to read instruments due to vibration	45
Take-off from carrier or other aviation ship	39
Reflection of lights on windshield	36
Awareness of flicker of rotors	35
Misperception of true horizon due to ground lights	33
Fatigue	32
Distraction by aircraft malfunction	29
Formation flying, night	25
Misled by faulty instrument	25
Vibration	24
Misjudgment of altitude following take-off from carrier or other aviation ship	21
Going IFR in dust, snow, water, in low hover	19
Loss of night vision	15
Take-off or landing in strong cross winds	13
Symptoms of cold or flu	11
Low altitude hover over water, day	10
Formation flying, day	8.6
Low altitude hover over land	6.7
In-air refueling from moving ship	2.8
Self-treatment with over-the-counter drugs	1.9
Landing on carrier or other aviation ship, day	0.96

(Adapted from Tormes & Guedry. 1975).

On the other hand, there are many maneuvers which induce disorientation, but the pilot is so aware of its occurrence that he may not be at all disturbed by it. For example, a plane flying in a level, coordinated, gentle bank and turn may be perceived as though it were in straight and level flight for reasons made clear in earlier sections and illustrated in Figure 3-7. The pilot who initiates the maneuver knows what to expect, and for this reason, the perceptual experience seems "natural" and is consistent with the intellectual information derived from his instruments. A pilot may not even refer to a false perception of the plane's attitude as disorientation if he is keeping track of the flight situation. This was illustrated by comments from an experienced F-4 pilot who, while serving as a backseat subject in an in-flight experiment, reported that a head movement induced an apparent 30 to 40 degree nose-down attitude of the aircraft which at the time was in a 2 g level bank and turn. When this experience was later referred to as an example of disorientation, the pilot-subject denied that he was disoriented at all because he was completely aware of the true attitude and condition of the aircraft. This illustrates an important point. The dangerous aspects of disorientation are considerably diminished if the pilot alertly keeps track of the true condition of the aircraft. When disorientation inputs become second nature to him, perceptual-motor reactions are probably modified and, in their modified form, may even enhance his control of the aircraft.

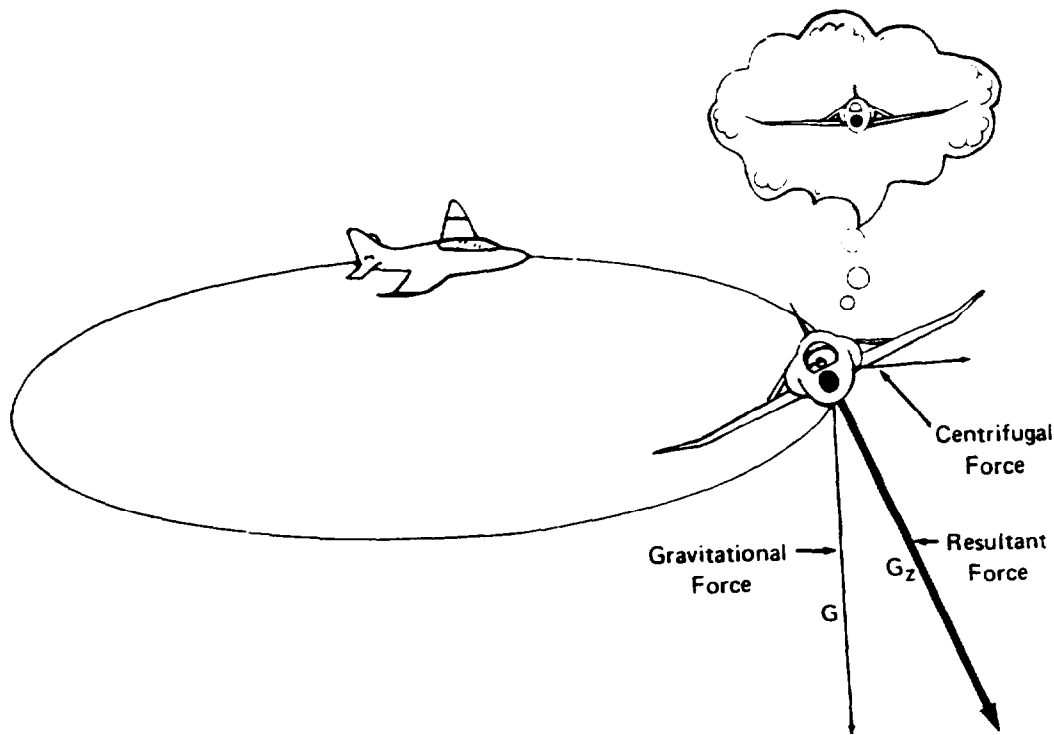

Figure 3-7. The somatogravic or oculogravic illusion. In a coordinated turn, the aviator may accept the resultant vector as gravitational vertical.

Vestibular Function

There is an exception, that being the case where a pilot may have persisting, strong disorientation, such as a severe case of “the leans.” The emotional reaction to the disorientation stress may impair instrument scan and normal control function. Here, the magnitude (or persistence) of the erroneous perception is a threat to the pilot. As in the case of the unanticipated disorientation, control of the aircraft may be jeopardized through the deleterious effects of hyperarousal (cf., Benson, 1965; Malcolm & Money 1972). Several points emerge from these considerations of the etiology of dangerous disorientation conditions: (1) Familiarity with conditions that produce disorientation and a “second-nature” anticipation of its occurrence can reduce its serious implications and may even be useful to the aviator; (2) Failure to keep track (i.e., intellectual updating) of the condition of the aircraft can convert even relatively benign flight conditions into potentially hazardous situations. For these reasons, training concerning conditions that can be expected to produce disorientation will have beneficial effects, and occasional refresher training is a worthwhile measure for the experienced aviator, especially after a period away from flying.

Visual-Vestibular Interactions Relevant to Aviator Vision

The Vestibulo-Ocular Reflex

The vestibulo-ocular reflex influences vision during natural movement much more than is generally appreciated, and it is capable of subtle and occasional profound influence on vision in aviation. Most physicians or physiologists think of nystagmus, an oculomotor pattern which occurs in certain unnatural motion profiles and in pathologic states, in relation to vestibular stimulation, but nystagmus is probably the least typical form of the vestibulo-ocular reflex in healthy individuals during natural movement. A more common oculomotor response consists of nearly smooth, sinusoidal eye oscillations that almost perfectly compensate for head oscillations that occur during walking, running, or simply shaking one’s head, as in signifying “yes” or “no”. For example, in the latter situation as the head turns right, the eye turns left, thereby *compensating* for the head movement (cf., Benson 1972). Gresty and Benson (in preparation) describe fairly high-frequency components (in the range 1 to 10 Hz) in angular oscillations of the head during whole-body movement and also in aircraft. It is important to note that the visual system is very poor at tracking Earth-fixed targets at these frequencies if it is unaided by the vestibulo-ocular reflex. Therefore, this reflex plays an important role in stabilizing vision relative to the Earth during many kinds of natural motion. The reader can demonstrate this to himself by holding his head *stationary* and oscillating this page back and forth on a desk top at a frequency just sufficient to blur the print. To complete the demonstration, and this is the crux of it, oscillate your head at the same frequency *while the page remains stationary* on the *desk top*, and observe that the print remains perfectly clear. Note also that even with much faster head oscillations it still remains clear. The vestibulo-ocular reflex automatically stabilizes the eyes relative to external

visual surroundings during head movements to maintain visual acuity for Earth-fixed targets. This is the reason that individuals without vestibular function report "jumbled vision" during motion, especially vehicular motion involving vibratory oscillation. However, following loss of vestibular function, the influence of neck proprioception on eye movement may increase to improve ocular stabilization during voluntary movement.

This highly advantageous vestibular-ocular reflex can become disadvantageous (inappropriate), however, in aircraft, surface ships, or other moving platforms since the head moves in inertial space, while visual displays, such as aircraft instrument panels, may move *in unison* with the head. If there is a tight coupling between head and display during such movement, then at certain frequencies and peak angular velocities, the vestibulo-ocular reflex will interfere with vision for the display (Guedry & Correia, 1978).

Vision and the Dynamic Response of the Cupula-Endolymph System

The probability of encountering problems with vision and also with disorientation in a given flight environment depends, among other things, on the dynamic response of the cupula-endolymph system to various profiles and frequencies of angular acceleration. Understanding this aspect of vestibular function is therefore helpful in analyzing problems arising from pathological conditions during natural movement or from normal responses to unusual motion. Because the cupula-endolymph ring has the structural characteristics of an overcritically damped torsion pendulum, its behavior and that of the responses it controls are theoretically predictable when acceleratory movements of the head are known. Much information was accumulated to indicate when such predictions are accurate and when they are not (cf., Guedry, 1974). Figure 3-8 illustrates predicted changes in cupula displacement relative to the skull throughout two motion conditions. Figure 3-8A, depicting cupula deflection during a simple, natural head turn to the left, illustrates several important points. Notice that the cupula deflection curve looks like the stimulus angular velocity curve and are not like the angular acceleration curve. In natural head turns, the dynamic response of the end organ is such that the input sensory message matches the instantaneous angular velocity of the head relative to the Earth (like a tachometer), even though angular acceleration is the effective stimulus. For this reason, the turning sensation (subjective angular velocity) controlled by cupula deflection is accurate during and after the turn. Similarly, the vestibulo-ocular reflex is accurate during natural turns in that the reflexive eye velocity compensates for the head velocity and stabilizes vision relative to Earth-fixed targets.

In contrast, Figure 3-8B illustrates vestibular effects of an unnatural motion involving sustained rotation. Inertial torque deflects the cupula during the initial brief angular acceleration, but it is absent during the following constant angular velocity. Consequently, the cupula, because of its

Vestibular Function

restorative elasticity, returns toward rest position. Then, being near rest position when deceleration occurs, it is deflected in the opposite direction by the inertial torque from the deceleration (angular acceleration in the opposite direction). The turning sensation controlled by cupula deflection is accurate only during the initial acceleration. During constant velocity, the sensation of turn will diminish and stop; then, the deceleration will produce a reversed sensation of turning which can persist for 30 to 40 seconds after stopping. Obviously, with the unnatural stimulus, the semicircular canals do not perform their velocity-indicating function satisfactorily, and their input can be the basis of disorientation and impaired visual performance.

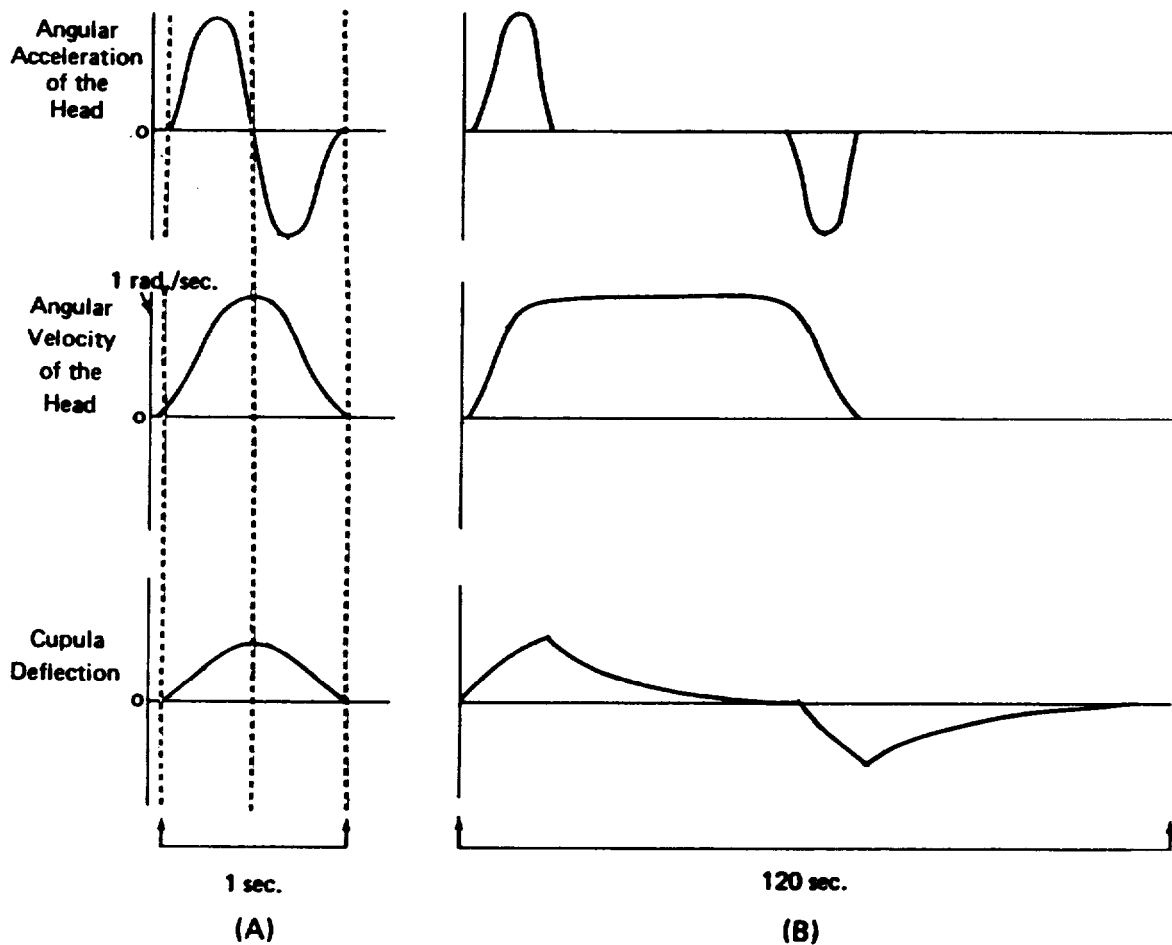

Figure 3-8. Comparison of cupula deflection during a natural short turn (A) and during a sustained turn of several revolutions (B).

This unnatural stimulus produces the particular pattern of oculomotor response called nystagmus. During the initial acceleration in Figure 3-8B, the eyes drift right (relative to the skull) as the head turns left. This drift, which compensates approximately for the turn, is called the slow phase of nystagmus, but as the head continues to turn, the eyes "recenter" themselves, that is, catch up, by a fast or saccadic eye movement called the fast phase, which has extremely high velocity (300 to 600 degree/second). Because the directions of the slow and fast phase of nystagmus are opposite, there has been inconsistency in designation of the direction of nystagmus. When viewed by a medical examiner, the fast phase (saccade) is easiest to see, and this led to the convention of designating nystagmus direction by its fast phase relative to the examinee. However, owing to recent strong clinical interest in quantification of nystagmus (electronystagmography - ENG) which emphasizes measurement of slow-phase velocity, designation of slow-phase direction has gained popularity. To avoid confusion, it is best to specify slow or fast phase when nystagmus is described. Figure 3-9 illustrates ENG as it typically appears when angular displacement of the eyes relative to the skull is recorded and also when the *slow-phase* velocity of each nystagmus waveform (beat) is quantified and plotted. The slow and fast phases create a sawtooth pattern. As the head commences to turn left during the initial acceleration, the eyes drift right (slow phase), adequately compensating for the head velocity. With continued rotation, the eyes catch up, (fast phase) and then recommence drift. During the period of constant head velocity, slow-phase eye velocity, as it abates, would be less and less effective in assisting the eye to see Earth-fixed targets. During deceleration, the reversed direction of nystagmus and its persistence after stopping could only impair vision for either Earth-fixed or head-fixed targets.

The nystagmus illustrated in Figure 3-9 approximates a typical response recorded in complete darkness. The maximum slow-phase velocity illustrated is 100 degrees per second. The nystagmus of a person with vision restricted to the interior of a rotating vehicle would be suppressed by any visible head-fixed display. With visual suppression, a maximum slow-phase velocity of about 14 degrees per second would occur (in other words, the visual/vestibular fixation index is about 0.14). This is sufficient to degrade visibility of fine detail on instruments briefly, until the suppressed vestibular nystagmus abates somewhat. The degradation is far less, however, than the total blurring of vision that would occur if the 100 degree/second slow-phase velocity were unsuppressed.

There are a number of conditions that influence visual suppression. With oscillatory motions, the frequency of oscillation is very important. During low frequency, whole-body oscillation (e.g., .01 Hz), the gain of the semicircular canal output response (peak slow-phase velocity/peak stimulus velocity) is low even in darkness, and the visual fixation index is favorable ($.14 \pm .05$ S.D.), so that visual fixation is apt to "win out" over vestibular nystagmus even with fairly high peak stimulus velocities.

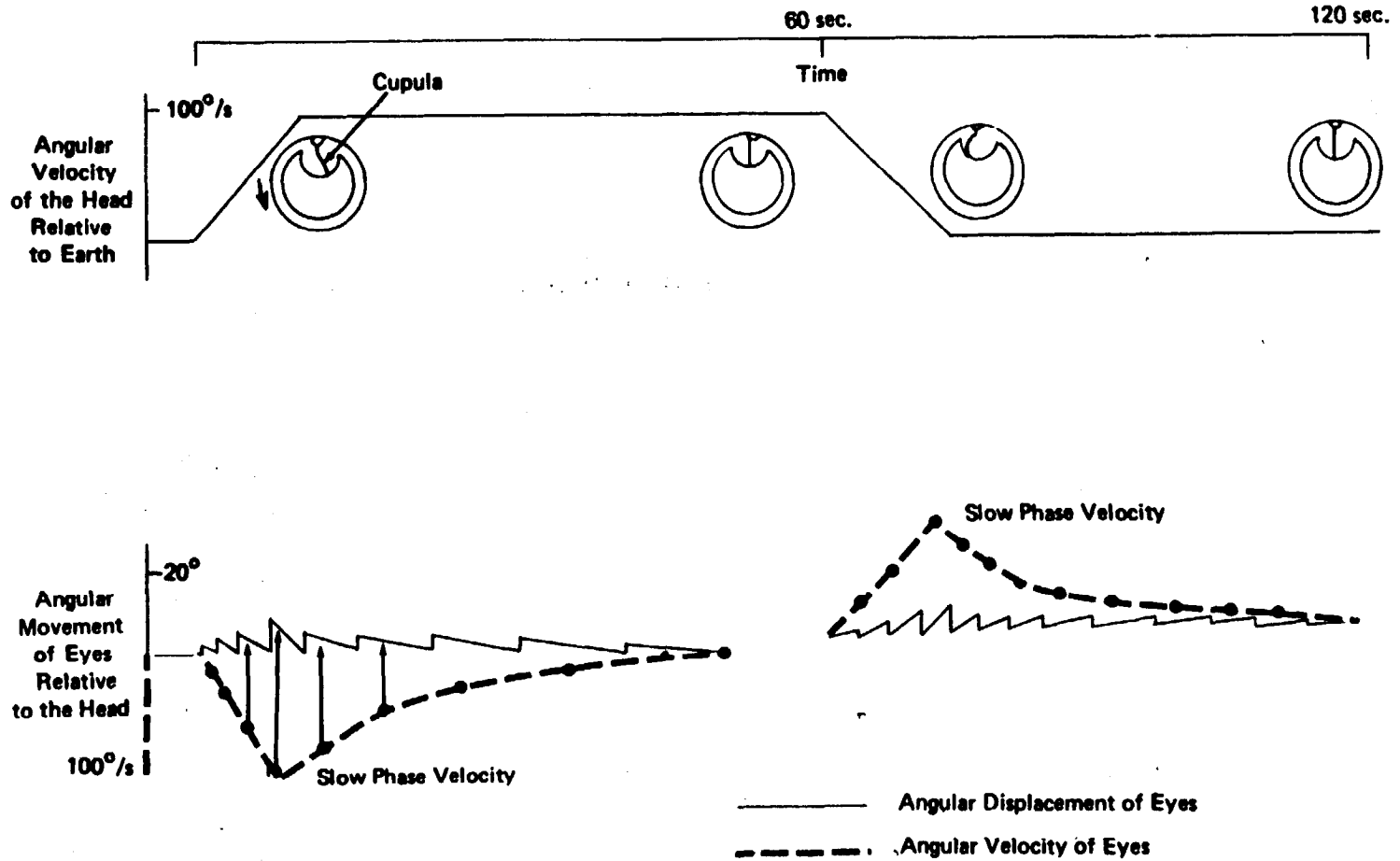

Figure 3-9. Electronystagmogram of cupula deflection and eye movements during and after prolonged rotation. Measuring the slope of the angular displacement tracing during a slow phase gives the slow phase velocity of the eyes.

However with high frequency head oscillation (e.g., 1.0 to 5.0 Hz), the gain of the vestibular output response is high (Benson 1970, 1972), and moreover, the fixation index becomes unfavorable. It approaches one, tantamount to little or no visual suppression. Thus, vision for head-fixed targets will be very poor even though the peak head velocity may be only 15 to 20 deg./sec., and the angle of oscillation only a few degrees (Barnes, Benson, & Prior, 1974).

Individual differences in visual suppression of vestibular nystagmus in apparently healthy persons can be quite large. A small amount of practice improves the visual fixation index (VFI) substantially in many but not in all persons. A fact that could be very important to an aviator is that a small amount of alcohol, two or three social drinks, degrades the VFI and associated visual acuity substantially for about four hours (Guedry, Gilson, Schroeder & Collins, 1975). One site of influence on the VFI is the cerebellum, particularly the flocculus (Lisberger & Fuchs, 1974; Miles & Fuller, 1975; Takemori & Cohen, 1974).

Nystagmus in the absence of unnatural motion stimuli is a clinically significant sign, although positional nystagmus can occur during alcohol intoxication (Positional Alcohol Nystagmus I -PAN I), and it can return, though reversed in direction (PAN II), during "hangover." Some pathological states reduce or eliminate visual suppression of nystagmus, and for this reason the VFI is a useful adjunct to other tests in diagnosing CNS disorders such as multiple sclerosis (Baloh, Konrad & Honrubia, 1975; Ledoux & Demanez, 1970). However, in many pathological states, especially peripheral vestibular disorders, visual suppression is effective. For example, nystagmus attributable to reduced function in one ear (see Figure 3-3) will be visually suppressed, and it may not be detectable by direct observation. For this reason, eye movements should be recorded by ENG in darkness. Alternatively, the physician may be able to detect nystagmus if he observes movement of the corneal bulge under the closed eyelid, or if the patient wears Fresnel lenses to blur vision.

Visibility of Cockpit Instruments

Loss of visibility of cockpit instruments has been indicated as a factor in disorientation in aviation (Melvill Jones, 1965; Tormes & Guedry, 1975). Malcolm and Money (1972) include inability to read flight instruments during vibration and turbulence as one of the conditions common to "Jet Upset Phenomenon," a situation in which pilots of large jet aircraft have gone into severe and disastrous nose-down attitudes to compensate for erroneous sensations of extreme nose-up attitudes (cf., Martin & Melvill Jones, 1965). Factors which may influence the visibility of flight instruments, separately and in combination, are the vestibulo-ocular reflex at high frequencies of head oscillation, poor visual system tracking with high-frequency instrument vibration relative to the head, the brightness and wavelength of light from the instruments, and the complexity of the

Vestibular Function

instrument display. Further complications may be introduced by tendencies toward “grayout” from changing G-loads which may be exacerbated by vestibular stimuli (Melvill Jones, 1957; Sinha, 1968).

Visibility Outside the Cockpit

Visibility of the Earth’s surface could actually be improved by the vestibulo-ocular reflex in some circumstances, although there is no certainty that the complex vibratory motions in flight would set off optimal oculomotor stabilization for Earth-fixed or other external visual targets. Some maneuvers, such as several consecutive complete turns, can produce vestibular aftereffects which tend to degrade vision due to nystagmus, while also disorienting the pilot. Despite good visual suppression of such effects, if maneuvers are sufficiently strong (e.g., five turns in ten seconds), vestibular nystagmus after stopping such a turn can blur vision for both cockpit instruments and Earth reference (Benson & Guedry, 1971; Melvill Jones, 1957). It has also been indicated that anticompany reflexes (Melvill Jones, 1964) and vestibulo-ocular accommodation reflexes (Clark, Randall & Stewart, 1975) may degrade vision in some flight conditions.

Vestibular Contributions to Disorientation

Aircraft maneuvers may involve both unnatural turns and unusual changes in the direction and magnitude of resultant linear force vectors. Moreover, the seated pilot does not necessarily continually update his orientation assessment as one does automatically while walking or running. Thus, both the pattern of vestibular stimulation and the response to it differ from those encountered in natural movement.

Somogyral and Oculogyral Illusions

Aircraft maneuvers involving several complete revolutions (turns, rolls, or spins) tend to produce an illusion of turning in the opposite direction just after the maneuver is completed. Contributing to this effect are semicircular canal responses as described above.

Stimulus and vestibular response characteristics which control the magnitude of the pre and postrotatory vestibular effects are the velocity of rotation achieved, the duration of the rotation, and, with some stimuli, the particular set of canals stimulated (Benson & Guedry, 1971). Constant velocity need not be maintained during the turn for some illusory aftereffect to occur. Whenever angular acceleration of constant direction is applied for several seconds, the continued cupula displacement is opposed by the elastic restoring force of the cupula, whereas, when the deceleration commences, the elastic restoring couple works with the inertial torque from the

“stopping” stimulus to produce cupula overshoot. Information from the semicircular canals would therefore signal “stop” before the actual maneuver ends, and would signal “reversed turn” from the cupula overshoot for any long duration triangular or sinusoidal waveform of angular velocity, even though no period of constant velocity interposed between the starting and stopping acceleration.

This sequence of perceptual events, when observed in complete darkness, has been called the “somatogyral illusion” (Benson & Burchard, 1973). Essentially the same sequence, when observed in darkness with only a small head-fixed visual display in view, has been called the “oculogyral illusion” (Graybiel & Hupp, 1946). In the latter case, the perceived motion of the body is referred to the visible display which therefore seems to be turning with the observer. However, the display may appear to lead slightly (i.e., be displaced from “apparent dead ahead” in the direction of the apparent motion), and it may be slightly blurred while the vestibular signal is strong enough to generate nystagmus in spite of visual suppression. The threshold for detection of angular acceleration seems to be lower for the oculogyral illusion than for the somatogyral illusion (Clark & Steward, 1969). From the point of view of aviation, it is important to note that these illusionary effects occur even in a well-illuminated cockpit if external visual reference is absent or ill-defined.

There is a curious difference in the aftereffects of active and passive whole-body rotation. The reader can demonstrate this to himself by standing and, with arms folded, executing eight, smooth, continuous ambulatory turns in about 20 seconds with eyes closed. Upon stopping (eyes still closed), if the body is allowed to remain fairly relaxed, the head, torso, and legs tend to twist in the same direction as the previous turn. The motor effects are in the expected compensatory direction from the deceleratory stimulus to the semicircular canals; they are compensating for a body motion which is not taking place. Under this circumstance, the after-sensation in most individuals is not one of turning in opposite direction, as would be predicted from the semicircular canal response, but rather of turning in the same direction as the preceding turning motion. The spinovestibular feedback apparently dominates the perceptual experience.

This demonstration has two potentially important implications in aviation. First, it illustrates that unusual vestibular stimuli can induce reflexive motions of the head, torso, and limbs that may not be appreciated by the pilot, yet they may influence performance. Secondly, the difference in after-sensation between active and passive turning may have implications for the perceptual experiences of pilots who actively generate unusual vestibular stimuli in flight maneuvers and, of course, continue to control the aircraft after maneuvers are completed. Experienced pilots develop what is referred to as “fusion,” in which the aircraft is said to become a mere extension of their voluntary control of motion (Reinhardt, Tucker & Haynes, 1968). Thus, the sensations of experienced pilots are probably shaped by their active control functions and may

be a little different than would be deduced from passive stimulation in laboratory devices. This would account for several indications that experienced pilots are much more disturbed by fixed-base flight simulators (Reason & Brand, 1975) with moving visual scenes than is the novice. The likelihood that the pilot's active control of his aircraft reflexively shapes his perceptual experience also has implications for the importance of maintaining flying practice.

Somotogravic and Oculogravic Illusions

The somotogravic and oculogravic illusions are sometimes referred to as the otolithic counterparts of the somatogyral and oculogyral illusions. They are apt to occur when the head and body are in a force field which is not in alignment with gravity, a condition that occurs frequently during flight and which is usually studied in the laboratory by means of a centrifuge. Although otolith stimulation plays a role in the effects of such stimuli, certainly other somatosensory receptors are also involved. Individuals without vestibular function experience these "illusions," although their perceptions differ somewhat from those of individuals with vestibular function (Graybiel & Clark, 1965).

The perception of feeling upright during a coordinated bank and turn (Figure 3-7) or its converse of feeling tilted when the resultant force field is not aligned with gravity, has been referred to as the "somotogravic illusion" (Benson & Burchard, 1973). For situations in which an observer views a line of light and either estimates its apparent tilt or attempts to adjust it to apparent vertical, the perceptual error has been called the "oculogravic illusion" (Graybiel, 1952). However, the important point for the aviator is that accelerations in flight can yield a resultant force vector which may be perceived as upright, even though it is substantially "tilted" relative to gravity.

Even in a diving turn, the resultant force can give the illusion of approximately level flight. Concentrating on maintaining positive relative to another aircraft, the pilot may feel approximately straight and level while in rapid descent. Even on a clear day over water, the horizon may not be immediately locatable, without immediate clear visual reference. The pilot is at high risk due to unrecognized disorientation.

While the direction of the resultant force vector provides a fairly close approximation of the subjective vertical in "steady state" conditions (i.e., conditions in which the observer experiences prolonged static tilt relative to the resultant force vector), there are a number of definite departures from this rule. One such departure results from conditions of dynamic (changing over time) linear and angular accelerations, as explained in the previous discussion of the coding of vestibular messages. During horizontal linear acceleration of an upright, forward-facing

observer, the resultant linear acceleration vector rotates in the pitch plane of the head and body. The otolith stimulation is as though the head and body had rotated backward relative to gravity, but, because the head is fixed in an upright position, there is no angular acceleration to stimulate the vertical semicircular canals. Under these circumstances, the immediate perceived change in orientation is usually less than that which would be calculated from the immediate stimulus to the otolith (Guedry, 1974, p. 105 f; cf., Stockwell & Guedry, 1970). This kind of situation occurs in linearly accelerating or decelerating aircraft, and, though some change in attitude is experienced, if the head does not rotate on the neck during the linear acceleration or deceleration, then the experienced change in attitude is probably less than the dynamic rotation of the linear acceleration resultant vector and hence closer to the actual attitude of the aircraft. Even so, there can be enough change in perceived attitude to introduce dangerous reactions in flight (Collar, 1946). An extreme example of this kind of stimulus occurs during a catapult launch from an aircraft carrier (Figure 3-10) (cf., Cohen, Crosbie, & Blackburn, 1972). During the catapult launch, a peak forward linear acceleration of about 4.5 g is generated. When resolved with gravity, the resultant linear acceleration vector makes an angle of about 77 degrees relative to gravity. In a few seconds, the resultant vector changes in magnitude and *rotates* relative to the pilot's head. Because the head has not actually rotated, the semicircular canals do not signal a corresponding rotation. The absence of vertical semicircular canal input combined with the dynamic otolith input produces a forward velocity sensation and less perceived nose-up attitude than would be predicted from the 77-degree change in direction of the resultant vector.

A second circumstance in which judgments of vertical are apt to depart from alignment with the existing force field occurs in the presence of a structured visual field. A prominent visual frame of reference with linear dimensions tilted relative to the direction of the existing force field will frequently produce a compromise estimate of the vertical between visual and force-field cues. It appears that some individuals are relatively more influenced by visual reference, whereas others may be more force-field oriented, and there has been some interest in exploring the implications of such differences for aeronautical adaptability (Bricton, 1975). Flight conditions giving rise to misleading visual reference will be discussed briefly in a later section.

Judgments of vertical may also depart from alignment with the resultant force field when the magnitude of the force differs substantially from the customary 1.0 g field. Systematic departures which appear to be attributable to differences in otolith displacement during static tilt in "hyper-g" fields have been observed (for an overview cf. Guedry, 1974, pp. 96-103).

Illusions Associated With Head Movements

Nuttall (1958) attributed a series of fatal aircraft accidents to pilots' head movements required

Vestibular Function

by the necessity to shift radio frequencies during procedural turning maneuvers at low altitudes. Several illusory effects can be elicited by head movements during such turning maneuvers.

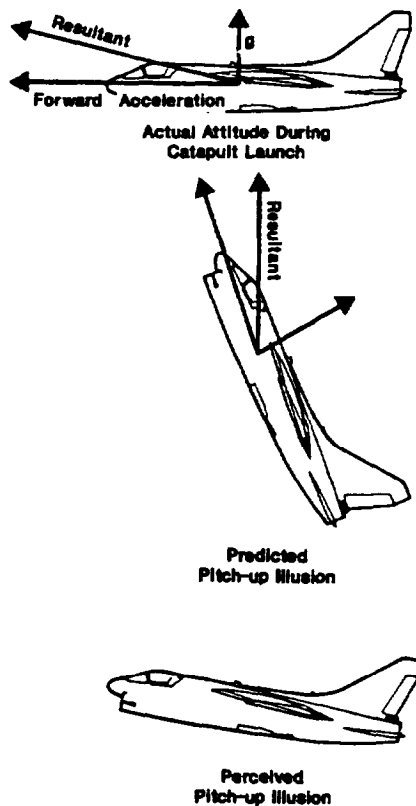

Figure 3-10. Actual aircraft attitude, predicted pitch-up illusion, and perceived pitch-up illusion during a catapult launch.

The Cross-Coupling Coriolis Illusion. When an aircraft rotates at some angular velocity ω_1 , about one axis while the pilot tilts his head about an orthogonal axis at some angular velocity ω_2 , the head undergoes an angular acceleration of magnitude $\omega_1 \omega_2$, about a third axis, orthogonal to the other two axes. A specific example will serve to clarify the effects that such a stimulus produces. Assume that an observer, on a turntable which has been rotating in a counterclockwise direction at a constant velocity ω_1 of 60 deg./sec. for 20 to 30 seconds, has his head fixed in tilted position toward his left shoulder. If he then moves his head to an upright position, he experiences a forward tumble and a slight leftward rotation. Vestibular nystagmus produced by the canal

stimulus is primarily down (fast phase) and slightly to the left. An important point to note here is that just after the head is upright, the otolith system would signal the true head position relative to gravity, yet the fairly strong residual effects from the stimulus to the vertical canals give a sensation of forward tumble (i.e., a perceived attitude change of the body and entire vehicle relative to Earth-vertical). Here, then, is a situation in which accurate information provided by the otoliths regarding orientation relative to the Earth is compromised by misleading canal signals, resulting in an illusory change in attitude. The perception is confusing and disturbing, probably because of the intravestibular conflict, and substantial, erroneous changes in attitude are reported (Clark & Stewart, 1967; Collins, 1968).

This effect is sometimes referred to as a Coriolis effect because the inertial torque which stimulates each canal can be derived by integrating the components of the linear Coriolis acceleration which act in alignment with the canal walls. From a practical point of view, the conditions that control the magnitude of the disturbing effect of natural rate head movement in flight are the total angle through which the head is turned (the greater the angle, the greater the total integrated stimulus) and the angular velocity (ω_1) of the aircraft. Time elapsed between the head movement and the onset of vehicle turn is also an important determiner (Guedry & Benson, 1976).

Aircraft in a bank and turn commonly do not have a very high angular velocity ω_1 . Under these conditions, the magnitude of cross-coupled (Coriolis) effects from head movements would be relatively slight, but, in the unstable conditions of flight, even slightly disorienting effects could be dangerous if external visual reference is either absent or misleading. In higher rate sustained turns, these effects can be strong, and since they may also induce physiological changes conducive to vasovagal syncope, it is not only disorientation but also a possibility of reduced g-tolerance which could affect the pilot (Sinha, 1968).

The "g-Excess" Illusion. There is another effect during head movements in aircraft which is apt to occur whenever the aircraft is generating an abnormal force field. This effect was observed during coordinated 2.0 g turns about a large radius (r) of several miles. In this maneuver, the aircraft speed (tangential linear velocity) is very high, but the angular velocity (ω_1) is very low, about 4 deg./sec. or .07 rad./sec. The center of turn may be at a radial distance of one or two miles from the aircraft. The 2-g resultant is obtained by resolving the gravity vector with the centripetal vector ($\omega_1^2 r$). To calculate centripetal acceleration, ω_1 must be expressed in radian units. The low angular velocity means that the cross-coupling (Coriolis) effects described in the preceding paragraphs would be almost negligible. Yet, during head movement in such turns, observers reported experiencing peculiar sensations sometimes involving sudden shifts in the apparent attitude of the aircraft, together with nausea which would undoubtedly culminate in sickness in some individuals if frequent head movements were made in this situation. This has been called a

Vestibular Function

“g-excess” because sensory signals from the otolith system when the head is moved in a high-g field would exceed those produced by the same head movement in a 1.0 g field. The extra otolith input may be perceptually attributed to a sudden maneuver of the aircraft, in which case a change in aircraft attitude in the plane of the head movement would be experienced. The perceived attitude change would be at right angles to the cross-coupled (Coriolis) effects. This is comparable to the effects of force-field magnitude on estimates of verticality described previously, except that head *movement* introduces a dynamic stimulus to the otolith system, and the perception is more confusing and less consistently reported (Gilson, Guedry, Hixson, & Niven, 1973). Note also that the head movements in weightless states are also nauseogenic and disorienting (Graybiel, Miller & Homick, 1974). While this phenomenon is not completely understood, it could be an example of intravestibular conflict (i.e., the head movements induce normal semicircular canal responses unaccompanied by the usual otolithic and proprioceptive feedback).

Pressure (Alternobaric) Vertigo

Pilots sometimes experience strong, sudden vertigo involving sensations of spinning, rolling, or tilting, and nystagmus sufficient to blur vision during or soon after ascent or descent. The pilot may feel his ears clear suddenly (sometimes a hissing sound is reported) and simultaneously experience strong vertigo. In one case, a member of one of the famous military aerobatic flight teams was so afflicted shortly after landing that for several minutes he was unable to walk from his plane to join his fellow team members who were being greeted by waiting dignitaries. Surveys (Lundgren & Malm, 1966; Melvill Jones, 1957) have indicated that from 10 to 17 percent of pilots experience pressure vertigo at one time or another. Usually the vertigo is transient, 10 to 15 seconds, but it may last much longer.

Pressure vertigo is vestibular in origin, but its exact mechanism is not understood. Even slow changes in ambient pressure can produce symptoms in some individuals. It is also sometimes induced by the Valsalva maneuver. High forcing pressures for opening the eustachian tube on one side, i.e., asymmetry in pressure equalization, seem to be common in individuals who experience pressure vertigo, and experimental studies (Tjernstrom, 1974) indicate that some individuals are much more susceptible to this form of vertigo than others. Aside from dangers associated with barotrauma, the strength of some attacks of pressure vertigo militate against flying with any condition which threatens pressure equalization in the middle ear.

The Giant Hand Phenomenon. Extreme disorientation where pilots have been unable to make corrective control stick actions with one or both hands has been referred to as the Giant Hand effect. This motor control anomaly appears to be induced by high stress due to sudden appreciation

of disorientation occasioned by a shift in the direction of the resultant force that was not perceived because the pilot had been distracted from control of the aircraft by other tasks. Upon releasing the control column, pilots have reported that the stick returned to a central position by itself and that they were able to effectively control the stick by use of the thumb and forefinger (Malcolm & Money, 1972). Recently, this effect has been reported to occur, to some degree, in about 18 percent of pilots interviewed (Simpson and Lyons, 1978).

There has been some indication that high-level sound, sustained and repetitive, and infrasound can also occasionally induce vestibular disturbances. (Parker, Ritz, Tubbs, & Wood, 1976).

Disorientation Not Attributable to Strong Vestibular Stimuli-Primacy of Vision

Many of the disorienting conditions described in previous sections would be considerably ameliorated or overcome by good visual reference to the Earth's surface. The single most important cause of pilot disorientation is the absence of adequate visual reference to the Earth because of darkness or adverse weather conditions. Certain flying conditions can introduce visual information that may be either directly disorienting or misinterpreted, but the crucial factor in the human response is that, without good visual reference to the Earth's surface, the remaining sensory data on spatial disorientation are not sufficiently reliable to permit safe piloting of aircraft. This was nicely demonstrated by Krause (1959) who measured times from occlusion of pilots' visual reference until the aircraft assumed a condition requiring 10,000 feet for recovery. Following banks and turns, times were typically 20 to 30 seconds, but even after level flight, mean times were on the order of 60 seconds. Many instances of pilot disorientation are less attributable to some overwhelming misleading vestibular response than to some subtle perceptual inconsistency or even to perceptual insensitivity to the acceleration environment.

Autogyral and Autokinetic Illusions

It is well known that a small, single, stationary light in an otherwise dark room will appear to move in a more or less random path, and that the direction and extent of apparent movement can be influenced by suggestion or the expectation of a stationary observer. A number of instances in which pilots have mistaken stars and other fixed light sources for moving aircraft have probably involved this "autokinetic" effect (Benson, 1965). Perhaps less well known is the fact that individuals in a rotatable but stationary structure frequently perceive rotation of the entire structure. This "autogyral" effect occurs in darkness or in illuminated but enclosed devices. Absence of specific motion cues does not ensure perceived stability when motion expectations are high.

Perception of Tilt

Typically, mean judgments of verticality are fairly accurate perceptions, but the range of judgments usually includes a few large errors even though an observer can devote his entire attention to this one task. In long flights where vibration and a number of momentary accelerations from turbulence do not demand corrective responses from the pilot, the threshold of corrective responses to vestibular stimuli may be raised by the "acceleration noise level." Perceptual errors may then approach the occasional extreme errors encountered in laboratory experiments and also those found in water immersion studies where very large errors in the perceived vertical have been noted (cf., Guedry, 1974, 88-92). Even without a background of "acceleration noise" or water immersion, there are large mean errors in estimates of verticality when tilts occur very slowly. For example, pitch and roll attitudes of 10 degrees are typically regarded as upright, whereas sensitivity to detection of slow tilt increases substantially if the subject is rotated about the axis that is being tilted (Benson, Diaz, & Farrugia, 1975). Very slow or sustained tilts diminish rate information from the otoliths and corroborative information from the semicircular canals, and thus increase the likelihood of adaptation effects (see the section on the sensory transduction of head motion into coded neural messages).

In flight, a gradual roll or pitch away from straight and level flight sometimes occurs at rates below the semicircular canal or otolith threshold perceptual levels. Adaptation can make a tilted position seem upright, so that return to upright produces a definite sensation of tilt in the opposite direction (Passey & Guedry, 1949). If a flight slowly entered a coordinated bank and turn, alignment of the resultant vector with the head to seat axis would allow for still further undetected deviation from straight and level flight. If the pilot should then become aware of the aircraft attitude from instrument information or external reference, his corrective actions could introduce vestibular stimuli considerably above threshold levels, indicating a definite change from an attitude which had just been perceived as straight and level. Circumstances such as these produce "the leans," one of the most common forms of disorientation reported by pilots (Clark, 1971). The cockpit instruments show that the aircraft is straight and level, yet the pilot feels that he is in a bank and turn. Though the pilot may be able to fly successfully by his instruments, prolonged perceptual conflicts can eventually degrade his performance. Curiously, "the leans" may persist for 30 minutes or more, much longer than predictable after-responses of the vestibular system. It is as though once the perceived vertical is displaced from the initial noncompelling sensory information about upright, then this displaced perception may sustain itself until the pilot attends for awhile to some other aspect of the flight task, or until there is a good visual reference to the Earth (Benson & Burchard, 1973). Emotional disturbances may further degrade "position sense."

Visual Stimuli and Disorientation

Considering the range of positions which may be judged to be vertical in the absence of clearly misleading information, it should not be surprising that "the leans" could also be provoked by misleading visual stimuli, such as sloping cloud banks, slanting rays of sunlight through clouds, rows of lights erroneously believed to be horizontal, and even the edge of the instrument glare shield sloping over the attitude gyro (Figure 3-11). Pilots occasionally find themselves in nearly inverted flight when just prior to the discovery they had believed themselves to be in normal level flight. The probability of this kind of error is enhanced by the fact that man's estimates of vertical are relatively poor in some tilt positions and especially when he is inverted (Graybiel & Clark, 1962). In these position, visual cues assume a more predominant role (Young, 1973).

Erroneous perception of aircraft attitudes can result in erroneous perception of aircraft altitude. A pilot whose aircraft is in nose-high attitude may, on viewing ground lights in his line of flight, believe his altitude to be considerably greater than it is because of the downward angle of his view of the lights. Similarly, a pilot flying over water with his port wing high may, on viewing shore lights on his port side at an approximately known distance, again considerably overestimate his altitude if he is unaware of the aircraft attitude (Cocquyt, 1953).

Visual effects at high altitude can also induce erroneous perceptions of attitude (Benson, 1965; Melvill Jones, 1957). At high altitude, the horizon is depressed with respect to the true horizontal so that orientation of the aircraft to this false reference may result in the aircraft being flown with one wing low or with a nose-down attitude. The magnitude of this error is not large, being about four degrees at 50,000 feet, but confusion can occur when the pilot looks out on the other side and finds that he is flying wing-high with respect to the visible horizon on that side.

Another illusion resulting from high altitude has been observed in which the pilot looks out from the aircraft and sees the moon and stars below the apparent horizontal. From this, he presumes that the aircraft must be flying in a banked or even inverted attitude. A number of pilots have made control movements to bring the aircraft back to what they thought was a normal attitude, before closer attention to their instruments revealed the erroneous nature of the visual percept (Melvill Jones, 1957). A similar situation may occur in the prolonged low altitude circling involved in ASW maneuvers. As indicated earlier, a sustained, coordinated bank and turn can easily be perceived as straight and level flight. If this occurs, a view from wing-high wide of the aircraft could place the moon and stars considerably below the erroneously perceived horizontal (Figure 3-12). possibly leading to the same kind of control errors reported by Melvill Jones in high-altitude flight.

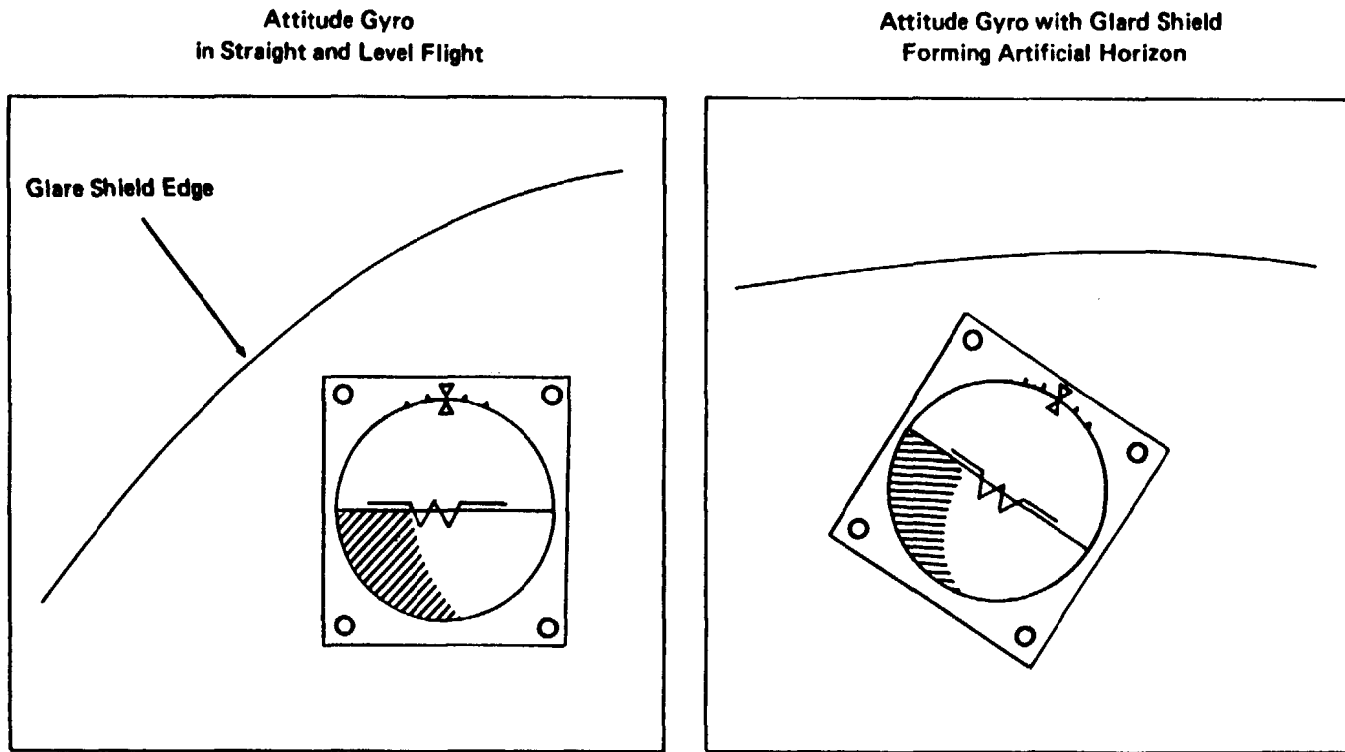

Figure 3-11. A potential false horizon illusion produced by the instrument glare shield (Tormes & Guedry, 1975). Published by permission of *Aviation, Space, and Environmental Medicine*.

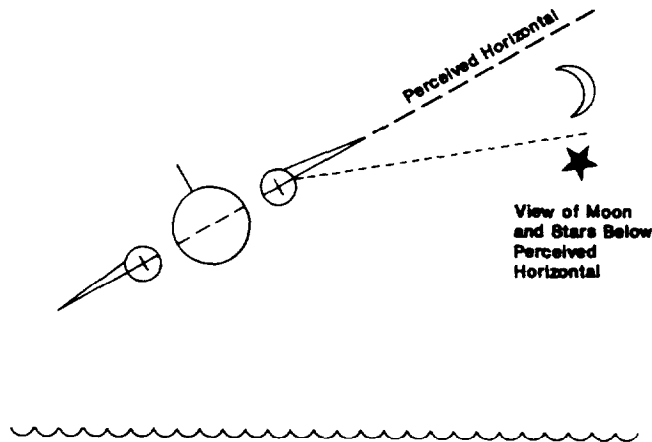

Figure 3-12. In a coordinated bank and turn, the pilot may see the moon and stars below the apparent horizontal. This can produce a momentary illusion of nearly inverted flight and lead to erroneous movements.

Dynamic Visual Stimulation

Large moving visual fields (visual angle greater than 30 degrees) can induce the sensation of body motion within three seconds and also substantial sensations of body tilt (Brandt, Dichgans, & Koenig, 1973; Brandt, Wist, & Dichgans, 1971; Dichgans, Held, Young, & Brandt, 1972). Of considerable interest are apparently related findings that large moving visual fields modulate neural activity in the vestibular nuclei even when the head and body remain stationary (Dichgans, Schmidt, & Graf, 1973; Young & Finley, 1974). In lower animals, vestibular stimulation modulates responses in central visual projection fields even when the retinal image is fixed (Bisti, Maffei, & Piccotino, 1974; Grusser & Grusser-Kornehls, 1972; Horn, Steckler, & Hill, 1972). These various results point to the intimate relations between the visual and vestibular systems in both the "feed forward" and "feedback" loops involved in the control of whole-body motion.

In aviation, either a large tilted frame of reference from cloud formations, etc., or uniform motion in the pilot's visual field can induce illusory perceptions of the attitude and motion of the aircraft. Such effects could influence the pilot in high-speed, low-level flight, or in any of several situations. A visually induced illusion appears to have been important in the following disorientation accident involving the loss of an aircraft. Toward the end of a long day of flying, a student pilot was flying on the starboard wing of his instructor's aircraft. The student's view was fixed on the instructor's aircraft, and because of this formation, his line of sight was turned almost 90 degrees to the line of flight as they descended for some time through heavy mist and layered

Vestibular Function

clouds. The unidirectional streaming of the peripheral visual field was therefore almost ideal for inducing sensations of whole-body turning to the right. As the student shifted his attention to his cockpit instruments, he experienced a strong illusory sensation of right bank and turn, although he was in fact in level flight. Following an erroneous corrective action based on his false perception, the student, now at fairly low altitude, ejected from his aircraft. Contributing to this unfortunate incident were a number of factors. The conditions were adequate to set up a normal illusory reaction to an unusual motion condition: The pilot had just transitioned from an external reference to instrument flight; the pilot was relatively inexperienced and fatigued; altitude and proximity of another aircraft provided little time for corrective actions. Probability of disorientation is high when pilots keep station on another aircraft.

Flicker Vertigo

Flashing light from sun rays or shadows reflecting from helicopter rotors or from blades of propeller driven, fixed wing aircraft can be very disconcerting, and, in exceptional cases, epileptiform seizures have resulted. In prop planes, the phenomenon may be strongest while the aircraft is taxiing into the sun so that the blades are rotating at relatively low rpm, and intense light flashes may be reflected into the eyes. In a helicopter survey, 35 percent of the pilots responding reported disturbance by flicker from rotors, but 70 percent reported difficulties arising from reflections from the anticollision light (Tormes & Guedry, 1975).

Perception of Vertical Linear Acceleration

Misjudgment of helicopter motion during hover was found to be a prominent factor in a number of disorientation incidents during conditions of poor external visibility. Moreover, extraneous motion stimuli such as a visible “salt” spray through rotor blades, wave motion, ship motion during night landings, and even wind currents in the cockpit can exacerbate the situation in naval helicopter operations (Tormes & Guedry, 1975).

Vertical linear oscillations introduce linear accelerations that are aligned with gravity so that the magnitude of the resultant force field changes relative to the head, but its direction does not. If an erect observer is oscillated vertically, the changing linear acceleration is approximately perpendicular to the utricular otolith plane, and, therefore, it is ineffective as a utricular stimulus. Its approximate alignment with the saccular otolithic plane would introduce an effective saccular “shear” stimulus, but the saccular otoliths, already deflected by a 1 g shear force, may be relatively insensitive to added acceleration in the same plane. From this theoretical point of view, otolithic insensitivity to vertical linear oscillation (VLO) as compared with its sensitivity to horizontal Linear oscillation (HLO) might be expected. Von Békésy (1940) reported accurate

amplitude estimates of high frequency (up to 4 Hz), small amplitude VLO, but his stimuli involved high peak accelerations at frequencies where otolith gain may be high. Recent neurophysiological findings (Fernandez & Goldberg, 1976) do not support the idea that otolithic neural input information would limit perception of VLO as opposed to HLO, but some perceptual data suggest that perceptual deficiencies may occur with low frequency stimuli. Walsh (1964) reported higher thresholds for 0.11 Hz VLO than he had previously reported (1961a, 1961b, 1962) for HLO, although his data are not entirely consistent (cf. Benson et al., 1975). Several experiments (Malcolm & Melvill Jones, 1974; Melvill Jones, Rolph, & Downing, 1974-1976) have indicated perceptual inaccuracies with VLO that seem excessive relative to fairly accurate perceptions of HLO in other studies (Guedry & Harris, 1963; Young & Meiry, 1968). Walsh (1964) reported large stimulus response phase errors (individuals experienced maximum downward travel during upward travel) at 0.11 Hz and zero phase error at 1.0 Hz. Other phase data (Melvill Jones et al., 1974-1976; Young & Meiry, 1968) for HLO and VLO are not consistent with Walsh (1962, 1964), probably due to differences in reporting methodology and in high-frequency stimulus artifacts. However, the averaged oculomotor responses in Melvill Jones et. al. (1974-1976) exhibited stimulus-response phase angles at 0.11 Hz and 1 Hz, consistent with Walsh's subjective data. Differences in body position (reclining in Walsh's studies, erect in other studies) may also contribute to some of the interexperimental differences. Spinovestibular interactions may modulate perceptual experience in the erect observer during VLO through mechanisms similar to those involved in the very different perceptual experiences noted above in the aftereffects of *active* versus *passive* turning.

The presence of substantial perceptual phase errors and even the inconsistencies within and between studies are relevant to the problems of aviators, especially pilots of helicopter and vertical/short takeoff and landing V/STOL aircraft. If methodological differences and stimulus artifacts influence perceptual consistency in formal experiments, the pilot will also be subject to perceptual inconsistencies and occasional large phase errors in the noisy acceleration environment of flight where he is variously occupied with different elements of his flight task.

Prevention of Disorientation

Disorientation of flight will be experienced at one time or another by all pilots who fly more than a few hours under conditions of poor visibility. However, the intensity of the experience, the ease with which it is resolved, and the frequency vary. Some pilots may be aware of disorientation on every flight while others are rarely troubled (Aitken, 1962). About 58 percent of the helicopter pilots questioned by Tormes and Guedry (1975) indicated one or more episodes of severe disorientation. It is therefore important to provide information and training on means and methods of avoiding disorientation, of overcoming it when it occurs, and of reducing residual anxieties resulting from disorienting experiences.

Aircrew Instruction on Causes of Disorientation (cf., Benson, 1974b)

It is important that aircrew know the following:

1. That disorientation is a normal reaction to a number of unusual conditions of motion that occur in flight.
2. The various types of illusory perceptions that are apt to occur in flight.
3. The flight conditions and maneuvers likely to produce disorientation.
4. How to cope with disorientation.

Disorientation Threat Checklist. Navy pilots receive indoctrination on aspects of all of these points in the course of their training, but reminders are necessary. Material presented earlier in this chapter will assist the flight surgeon in amplifying on Points 1 and 2. The following is a useful checklist for reviewing factors which constitute disorientation threats to the aviator in a helicopter or in fixed wing aircraft.

1. *Flight Environment.*
 - a. IFR - in particular, the transfer from external visual to instrument cues.
 - b. Night - ground/sky confusion. Isolated light sources enhance the probability of oculogravic, oculogyral, and autokinetic illusions.
 - c. High Altitude - false horizontal reference. Dissociative sensations of detachment or remoteness from aircraft, from Earth, or from reality (break-off phenomenon). "Break-off" may occur in helicopter pilots at lower altitudes or on crossing escarpments.
 - d. Flight Over Featureless Terrain - false perception of height.
2. *Flight Maneuvers.*
 - a. Prolonged acceleration and deceleration in line of flight and catapult launches - somatogravic and oculogravic illusions.
 - b. Prolonged angular motion - sustained motion not sensed; somatogyral illusions on recovery; no sensation of bank during coordinated turn; cross-coupled and "g-excess" illusions if head movement is made while turning.
 - c. Subthreshold changes in altitude - "the leans" induced on recovery.
 - d. Workload of flight maneuvers - High arousal enhances disorientation and reduces the ability to resolve perceptual conflict.
 - e. Ascent or descent - pressure vertigo.
 - f. Cloud penetration - VFR/IFR transfer and attendant problems especially when flying in formation or on breaking formation. In the "lean on the sun" illusion a

bright spot in the cloud may be interpreted as up. Depending upon the heading of the aircraft relative to the bright spot, the false vertical reference may induce attitude errors in roll and pitch.

3. *Aircraft Factors.*

- a. Inadequate instruments.
- b. Inoperative instruments.
- c. Visibility of instruments.
- d. Badly positioned displays and controls - head movement required to see and operate.
- e. High rates of angular and linear acceleration, high maneuverability.
- f. View from cockpit - Lack of visible aircraft structure enhances "break-off" and provides a poor visual frame of reference.

4. *Aircrew Factors.*

- a. Flight experience.
- b. Training, experience, and proficiency in instrument flight.
- c. Currency of flying practice.
- d. Physical health - upper respiratory tract infection and "pressure vertigo".
- e. Mental Health - High arousal and anxiety increase susceptibility to disorientation.
- f. Alcohol and drugs - impaired mental function. Alcohol and barbituates, even at low levels, impair ability to suppress nystagmus.
- g. Fatigue or task overload.

Flight Conditions. Table 3-2 and the following specific list of conditions leading to disorientation were derived from a survey of Navy helicopter disorientation incidents:

1. Perception of the wind through cockpit side window while in hover or translational lift.
2. Flying into smoke flares.
3. Task saturation.
4. Wave motion interpreted as aircraft motion.
5. Hot switch (crew change while rotors engaged) at night.
6. Low-altitude search pattern at night.
7. Night launch from forward spots on flight deck.
8. Lack of recent instrument flying.
9. Relative immobilization by wet suit for prolonged periods.
10. Communication difficulty (noise, poor radio discipline).
11. Excessive translational lift vibration.
12. Hover not level.

Vestibular Function

13. Reflection of anticollision lights.
14. Vibration dampeners on instrument panel inadequate, allowing blurring of instruments.
15. Light from middle console reflects on middle windscreen.
16. Cyclic stick not in center neutral position in level flight.

These lists of flight conditions and maneuvers that induce disorientation are helpful, but they are certainly not all-inclusive. For example, maneuvers such as barrel rolls and Cuban eights that involve temporary inverted flight can induce confusion. At the point of inversion, the pilot tends to move his controls in the wrong direction for completing the maneuver. The interested Flight Surgeon can develop a substantial catalog of flight conditions that tend to induce disorientation by dialogue with pilots. Pilots are frequently interested in describing their experiences and also their methods of resolving problems with disorientation.

Aircraft Factors. It is important to remember that there are factors peculiar to each aircraft which can contribute to disorientation. For this reason, Flight Surgeons should be alert to these factors in discussions with pilots because of knowledge of conditions peculiar to a given aircraft may be useful information for general dissemination to the squadron and may also be helpful in understanding problems reported by individuals.

Aircrew Factors. Surveys have shown that flight experience does not prevent disorientation (Moser, 1969; Ninow, Cunningham, & Radcliffe, 1972), but the incidence appears to be reduced with increasing experience. Current flying practice is helpful in several ways. A number of studies of repeated exposure to unusual motion have shown that both disturbance and counter productive reflexive actions are diminished or modified in a productive direction as a result of repetitive experience with unusual motions (Guedry & Correia, 1978). It is not unlikely that disruptive perceptual-motor reflexive responses diminish and in their modified form are useful to the pilot at a subconscious level in providing the feel of flight maneuvers. Something like this is needed to account for the fact that highly experienced pilots are highly disturbed, whereas the novice is not, by fixed base simulators in which the visual scene moves in response to control action.

Instrument skills are highly dependent upon practice. Interpretation of instrument information is an intellectual function which demands integrating symbolic orientation cues from some instrument with digital information from others. Recently, there have been efforts to make use of the strong perceptual effects of *large* moving visual displays (cf., Dichgans et. al., 1972) to combat "the leans." Servo-driven artificial horizons subtending a 160 degree can be projected onto aircraft instrument panels, and they appear to be more compelling than information intellectually derived from the usual, small aircraft instruments (Malcolm, Money, & Anderson, 1975). However, with current aircraft instruments, the information provided may be far less compelling

than the direct perceptual response to some unusual flight conditions. Yet, the pilot must use the intellectually derived information from his instruments. By the time instrument scan information becomes second nature, the pilot may be unaware of many disorienting sensations because his control actions may be overriding these sensations, and he is also highly proficient in the use of his instruments. The out-of-practice, "experienced" pilot may have partially lost both of these advantages and may be more at risk than the novice if he is overconfident and enters threatening flight conditions. For this reason, refresher training in the form of lecture material, demonstrations, and dual flying prior to resuming operational flights is desirable. Some experienced pilots may feel they are immune to disorientation, but exposure to a simple, ground based motion device is ordinarily sufficient to remind the aviator that he is, in fact, not immune. The pilot with many flying hours will have learned much about disorientation and coping with it, but the causes of disorientation are so numerous that he is unlikely to have had experience with every type. Pressure vertigo may occur only one time, but awareness of its potential effects may be sufficient to cause the pilot with a cold to avoid flying, or to enable the pilot who experiences it to remain sufficiently calm to combat it. Thus, knowledge of conditions that increase the probability of disorientation can serve to avoid it and also serve to reduce debilitating hyperarousal when and if it occurs. Ground based demonstration of normal disorientation experiences has been received with enthusiasm by experienced as well as beginning aviators in the RAF and is considered critical to effective training (Benson, 1980). The Multistation Spatial Disorientation Demonstrator (MSDD, Pensacola) provides demonstration of all of the effects produced by the RAF demonstrator, as well as additional visual effects.

Aircrew Instruction on Prevention and Coping with Disorientation

Although knowledge of conditions that produce disorientation is important to aircrew, they should never hear about the illusions occurring in flight and the consequences of disorientation without also hearing the instructions for how to deal with the problem. In this connection, several articles (Benson, 1974b; Benson & Burchard, 1973) have listed practical advice to aircrew for preventing and coping with disorientation.

How to Prevent Disorientation.

1. Remain convinced that you cannot fly by the "seat of your pants."
2. When flying wing on another aircraft, remember your perceived aircraft attitude often differs substantially from your true aircraft attitude because you are concentrating on the other aircraft. This is a dangerous form of disorientation.
3. Do not allow control of the aircraft to be based at any time on "seat of the pants" sensations, even when temporarily deprived of visual cues.

Vestibular Function

4. Do not unnecessarily mix flying by instruments with flying by external visual cues.
5. Aim to make an early transition to instruments when flying in poor visibility, once established, stay on instruments until use of external cues is clearly practical.
6. Maintain high proficiency and practice in flying under IFR conditions.
7. Become thoroughly familiar with instruments. When transitioning to newer aircraft, new instruments are often confusing.
8. Do not fly with an upper respiratory tract infection, when under the influence of drugs or alcohol, or when mentally or physically debilitated.
9. Remember, experience does not make you immune.

How to Cope With Disorientation.

1. Persistent minor disorientation (e.g., the leans) may be dispelled by making a positive effort to redirect attention to other aspects of the flying task; a quick shake of the head, provided aircraft is straight and level, is effective with some pilots.
2. When suddenly confronted by strong illusory sensations or when experiencing difficulties in establishing orientation and control of the aircraft, follow these procedures:
 - a. Get onto instruments; check and crosscheck. Ensure good illumination.
 - b. Maintain instrument reference. Control the aircraft in order to make the instruments display the desired flight configuration. Do not attempt to mix flight by external visual references with instrument flight until external visual cues are clearly practical.
 - c. Maintain correct instrument scan; do not omit altimeter.
 - d. Use advance headwork on necessary control actions in those maneuvers that typically produce confusion (e.g., inverted position in barrel roll).
 - e. Seek help if severe disorientation persists. Hand over to copilot (if present), call ground controller and other aircraft, check altimeter.
 - f. If control cannot be regained, abandon aircraft.
3. Remember: Nearly all disorientation is a normal response to the unnatural environment of flight. If you have been alarmed by a flight incident, discuss it with colleagues, including your medical officer or flight surgeon. Your experiences will probably not be as unusual as you thought.

Additional Information for Helicopter Crews. A list for avoiding and coping with disorientation in helicopters (Tormes & Guedry, 1975) was essentially a duplicate of the above except for the following items:

1. When disorientation occurs, fly straight and level and increase forward airspeed.

2. In weather, turn off the forward rotator beacon.
3. Always fly with a trimmed stick, (i.e., aircraft flies level with stick neutralized).
4. When disorientation occurs in hover, depart hover, and increase forward airspeed.
5. Upon entry into a cloud bank, turn 180 degrees unless under positive control.

Evaluation and Management of Disorientation Problems

One major factor in coping with disorientation is the pilot's ability to maintain composure and intellectual command of the aircraft despite distractions and disorienting inputs. Psychological disturbance is, therefore, one factor to be seriously considered by the Flight Surgeon in pilots whose presenting symptom is disorientation (O'Connor, 1967). Impairment of higher mental function and the reduced motor coordination that frequently accompany hyperarousal can obviously be side effects of fatigue, tension due to personal problems, or poor health. Alcohol and various drugs are additional threats to the effective resolution of disorientation problems. To a surprising degree, they can reduce visual control of eye movements in motion environments, while at the same time risking impairment of necessary intellectual control.

While probing for psychological factors, it is, however, necessary to bear in mind that individuals who experience strong vertiginous episodes as a result of some pathological condition are also frequently greatly disturbed by the experience. The emotional disturbance may then lead to the conclusion by the doctor as well as by the patient's friends that the whole episode is a sign of neurosis or an anxiety reaction. The same is true of the aviator who has had an exceptional disorientation episode. Whatever the actual cause of the disorientation, the emotional overlay that is likely to result from the episode must be dealt with.

In handling such cases, it is important for the doctor to show that he is interested. This will ordinarily be accomplished in the process of taking a history of the incident and relevant background material. A thorough history is perhaps the most important step in the examination.

It is first necessary to establish clearly whether or not the occurrence of disorientation in a pilot is due to a natural response to an unusual flight condition. The absence of similar reports by others in the aircraft does not by itself constitute evidence of an abnormal reaction from the pilot. Crew members may have been equally disoriented without awareness of the fact because awareness sometimes depends upon checking the perceptual event against information from the instrument panel or from sudden VFR contact.

In attempting to relate disorientation to flight conditions, items in the check lists should be considered. When it appears that disorientation is attributable to normal reactions to either aircraft

Vestibular Function

or flight conditions, then reassurance that the reaction was normal, possibly including discussion with other pilots, may be sufficient to allay anxiety. If concern persists, then a period of dual flight may serve to restore confidence, but it may be necessary to seek the help of a specialist (cf., O'Connor, 1967). There is some evidence that acquired fear of some aspect of flying in a previously confident aviator is amenable to treatment with a fairly high probability of success (Goomey, 1973; O'Connor, Lister & Rollins, 1973).

Organic causes of disorientation are discussed in Chapter 8 on *Otorhinolaryngology*.

References

- Aitken, R.C.B. Factors influencing flight safety (IAM Rept. R-209). Farnborough, England: RAF institute of Aviation Medicine, 1961.
- Baloh, R.W., Konrad, H.R., & Honrubia, A. Vestibulo-ocular function in patients with cerebellar atrophy. *Neurology*, 1975, 25, 160-168.
- Barnes, G.R., Benson, A.J., & Prior, A.R.J. Visual suppression of inappropriate eye movements induced by vestibular stimulation. *Workshop of the European Brain and Behavior Society: Vestibular Function and Behavior*, Pavia, Italy, April 25-26, 1974.
- Benson, A.J. Spatial disorientation in flight. In J.A. Gillies (Ed.), *A textbook of aviation physiology*. London/New York: Pergamon Press, 1965.
- Benson, A. J. Interactions between semicircular canals and gravireceptors. In D.E. Busby (Ed.), *Recent advances in aerospace medicine*. Proceedings of the 18th International Congress of Aviation and Space Medicine, Amsterdam, 1969. Dordrecht, Holland: D. Reidel Pub. Co., 1970. pp. 250-261.
- Benson, A.J. Effect of angular oscillation in yaw on vision. *Proceedings of the Aerospace Medical Association Scientific Meeting*. Washington, D.C.: Aerospace Medical Association, 1972, 43-44.
- Benson, A.J. Modification of the response to angular accelerations by linear acceleration. In H.H. Komhuber (Ed.), *Handbook of sensory physiology* (Vol. VI, Part 2). Berlin/Heidelberg/New York: Springer-Verlag, 1974a. 281-320.
- Benson, A.J. Orientation/disorientation training of flying personnel: *A working group report* (AGARD-R-625). London: Technical Editing and Reproduction Ltd., 1974b.
- Benson, A.J. The Royal Air Force Spatial Disorientation Familiarization Device. NATO/AGARD Conference Proceedings No. 287 (AGARD-CP-287), pp. B-11-1 through B-11-7, October 1980.
- Benson, A.J., & Burchard, E. Spatial disorientation in flight. *A handbook for aircrew* (AGAR-Dograph AG-170). London: Technical Editing and Reproduction Ltd., 1973.
- Benson, A.J., & Guedry, F.E. Comparison of tracking task performance and nystagmus during sinusoidal oscillation in yaw and pitch. *Aerospace Medicine*, 1971, 42, 593-601.
- Benson, A.J., Diaz, E., & Farrugia, P. The perception of body orientation relative to a rotating linear acceleration vector. In H. Schone (Ed.), *Mechanisms of spatial perception and orientation as related to gravity*. Stuttgart: Gustav Fisher-Verlag, 1975.
- Bisti, S., Maffei, L., & Piccotino, M. Visual-vestibular interactions in the cat superior colliculus. *Journal of Neurophysiology*, 1974, 37, 145-155.

U.S. Naval Flight Surgeon's Manual

- Brandt, T., Dichgans, J., & Koenig, E. Differential effects of central versus peripheral vision on egocentric and exocentric motion perception. *Experimental Brain Research*, 1973, 16, 476-491.
- Brandt, T., Wist, E., & Dichgans, J. Oprisch indeczierte pseudocoriolis- effekte and circularvektion. *Archiv fuer Psychiatrie und Nervenkrankheiten (West Germany)*, 1971, 214, 365-389.
- Bricton, C.A. Evaluation of the special senses for flying duties: Perceptual abilities of landing signal officers (LSO's) (AGARD CP-152). London: Technical Editing and Reproduction Ltd., 1975.
- Clark, B. Pilot reports of disorientation across four years of flight. *Aerospace Medicine*, 1971, 42, 708-712.
- Clark, B., & Stewart, J.D. Attitude and Cotiolis motion in a flight simulator. *Aerospace Medicine*, 1967, 38, 936-940.
- Clark, B., & Stewart, J.D. Effects of angular acceleration on man, thresholds for the perception of rotation, and the oculogyral illusion. *Aerospace Medicine*, 1969, 40, 952-956.
- Clark, B., Randall, R., & Stewart, J.D. Vestibulo-ocular reflex in man. *Aviation, Space, and Environmental Medicine*, 1975, 46, 1336-1339.
- Cocquyt, P.P. Sensory illusions. *Shell Aviation News*, 1953, pp. 178-186.
- Cohen, M.M., Crosbie, R.J., & Blackburn, L.H. Disorienting effects of aircraft catapult launches. In A.J. Benson (Ed.), *The disorientation incident* (AGARD CP-95 - Part 1). London: Technical Editing and Reproduction, Ltd., 1972.
- Collar, A.R. On an aspect of the accident history of aircraft taking off at night. Aeronautical Research Council Reports and Memoranda No. 2277. London: HMSO, August 1946
- Collins, W.E. Coriolis vestibular stimulation and visual surrounds. *Aerospace Medicine*, 1968, 39, 125-138.
- Correia, M.J., & Guedry, F.E. The vestibular system: Basic biophysical and physiological mechanisms. In R.B. Masterson (Ed.), *Handbook of behavioral neurobiology*. New York: Plenum Publishing Corp., 1978.
- Dichgans, J., Held, R., Young, L.R., & Brandt, T. Moving visual scenes influence the apparent direction of gravity. *Science*, 1972, 178, 1217-1219.
- Dichgans, J., Schmidt, C.L., & Graf, W. Visual input improves the speedometer function of the vestibular nuclei in goldfish. *Experimental Brain Research*, 1973, 18, 319-322.
- Fernandez, C., & Goldberg, J. Physiology of peripheral neurons innervating otolith organs of the squirrel monkey. *Journal of Neurophysiology*, 1976, 39, 970-1008.
- Fernandez, C., Goldberg, J.M. & Abend, W.K. Response to static tilts of peripheral neurons innervating otolith organs of the squirrel monkey. *Journal of Neurophysiology*, 1972, 35, 978-997.
- Gillingham, K.K., & Krutz, R.W. Effects of the abdominal acceleratory environment of flight (SAM TR-74-57). Brooks AFB, Texas: USAF School of Aerospace Medicine, 1974.
- Gilson, R.D., Guedry, F.E., Hixson, W.C., & Niven, J.I. Observations on perceived changes in aircraft attitude attending head movements made in a 2-g bank and turn. *Aerospace Medicine*, 1973, 44, 90-92.
- Goldberg, J.M. & Fenandez, C. Vestibular mechanisms. *Annual Review of Physiology*, 1975, 37, 129-162.
- Goorney, A.B. Assessment of behavior therapy in the treatment of flying phobias. In P.J. O'Connor (Ed.), *Clinical psychology and psychiatry of the aerospace operational environment* (AGARD CP-133). London: Technical Editing and Reproduction Ltd., 1973.
- Graybiel, A. Oculogravic illusion. *AMA Archives of Ophthalmology* 1952, 48, 605-615.
- Graybiel, A., & Clark, B. Perception of the horizontal or vertical with the head upright, on the side, and

Vestibular Function

- inverted under static conditions, and during exposure to centripetal force. *Aerospace Medicine*, 1962, 33, 147-155.
- Graybiel, A., & Hupp, D.I. The oculo-gral illusion. *Journal of Aviation Medicine*, 1946, 3, 1-12.
- Graybiel, A., & Clark, B. The validity of the oculo-gravic illusion as a specific indicator of otolith function. *Aerospace Medicine*, 1965, 36, 1173-1181.
- Graybiel, A., Miller, E.F., & Homick, J.L. Experiment M-131. Human vestibular function. In R.S. Johnston & L.F. Dietlein (Eds.), *The proceedings of the Skyfab life science symposium* (Vol. 1) (NASA TM X-58154, JSC-09275). Houston, Texas: NASA, Johnson Space Center, November 1974.
- Gresty, M., & Benson, A.J. Movement of the head in pitch during whole body activities. 1976
- Grusser, O.J., & Grusser-Komehls, U. Interaction of vestibular and visual inputs in the visual system. In A Brodal & O. Pompeiano (Eds), *Progress in Brain Research*, 1972, 37, 573-583.
- Guedry, F.E. Psychophysics of vestibular sensation. In H.H. Kornhuber (Ed.), *Handbook of sensory physiology* (Vol. VI, Part 2). Berlin/Heidelberg/New York: Springer-Verlag, 1974.
- Guedry, F.E., & Benson, A.J. Coriolis cross-coupling effects: Disorienting and nauseogenic or not? (NAMRL-1231). Pensacola, FL: Naval Aerospace Medical Research Laboratory, 1976.
- Guedry, F.E., & Correia, M.J. Vestibular function in normal and in exceptional conditions. In R.B. Masterson (Ed.), *Handbook of behavioral neurobiology*. New York: Plenum Publishing Corp., 1978.
- Guerdy, F.E., & Harris, C.W. Labyrinthine functions related to experiments on the parallel swing (NSAM-874, Rept. No. 86). Pensacola, FL: Naval School of Aviation Medicine, 1963.
- Guerdy, F.E., Gilson, R.D., Schroeder, D.J., & Collins, W.E. Some effects of alcohol on various aspects of oculomotor control. *Aviation, Space, and Environmental Medicine*, 1975, 46, 1008-1013.
- Henn, V., Young, L.R., & Finley, C. Vestibular nucleus units in alert monkeys are also influenced by moving visual fields, *Brain Research*, 1974, 71, 144-149.
- Hixson, W.C., & Spezia, E. Incidence and cost of orientation-error accidents in Regular Army aircraft over a five-year period: Summary report (NAMRL-1238, USAARL 77-19). Pensacola, FL: Naval Aerospace Medical Research Laboratory, 1977.
- Hixson, W.C., Niven, J.I., & Correia, M.J. Kinematics nomenclature for psychological accelerations (Monograph 14). Pensacola, FL: Naval Aerospace Medical Institute, 1966.
- Horn, C., Steckler, G., & Hill, R.M. Receptive fields of units in the visual cortex of the cat in the presence and absence of bodily tilt. *Experimental Brain Research*, 1972, 15, 113-132.
- Krause, R.N. Disorientation: An evaluation of the etiologic factors. Brooks AFB, Texas: Air University, School of Aviation Medicine, 1959.
- Ledoux, A., & Demanez, J.T. "Ocular fixation" index in the caloric test. In J. Stahle (Ed.), *Vestibular function on Earth and in space*. Oxford: Pergamon Press, 1970.
- Lindeman, H.H. *Studies on the morphology of the sensory regions of the vestibular apparatus*. Berlin/Heidelberg/New York: Springer-Verlag, 1969.
- Lisberger, S.G., & Fuchs, A.F. Response of flocculus Purkinje cells to adequate vestibular stimulation in the alert monkey: Fixation versus compensatory eye movements. *Brain Research*, 1974, 69, 347-353.
- Lundgren, C.E.G., & Malm, L.U. Alternobaric vertigo among pilots. *Aerospace Medicine*, 1966, 37, 178-180.
- Malcolm, R., & Melvill Jones, G. Erroneous perception of vertical motion by humans seated in the upright position. *Acta Otolaryngologica* (Stockholm), 1974, 77, 274-283.

U.S. Naval Flight Surgeon's Manual

- Malcolm, R., & Money, K.E. Two specific kinds of disorientation incidents: Jet upset and giant hand. In A.J. Benson (Ed.), *The disorientation incident* (AGARD CP-95 - Part 1). London: Technical Editing and Reproduction Ltd., 1972.
- Malcolm, R., Money, K.E. & Anderson, P. Peripheral vision artificial horizon display. In H.E. von Gierke, (Ed.), *Vibration and combined stresses in advanced systems* (AGARD CP-145). London: Technical Editing and Reproduction Ltd., 1975.
- Martin, J.F., & Melvill Jones, G. Theoretical man-machine interactions which might lead to loss of aircraft control. *Aerospace Medicine*, 1965, 36, 713-717.
- Melvill Jones, G. Current problems associated with disorientation in man-controlled flight (FPRC Rept. 1021). Farnborough, England: RAF Institute of Aviation Medicine, 1957.
- Melvill Jones, G. Predominance of anticompensatory oculomotor response during rapid head rotation. *Aerospace Medicine*, 1964, 35, 965-968.
- Melvill Jones, G. Disturbance of oculomotor control in flight. *Aerospace Medicine*, 1965, 36, 461-465.
- Melvill Jones, G., Rolph, R., & Downing, G.H. Human subjective and reflex responses to sinusoidal vertical acceleration (DRB Aviation Medicine Research Unit Reports [Vol V]). Montreal: McGill University and Ottawa: Defense Research Board, 1974-1976.
- Miles, F.A., & Fuller, J.H. Visual tracking in the primate flocculus. *Science*, 1975, 189, 1000-1002.
- Moser, R. Spatial disorientation as a factor in accidents in an operational command. *Aerospace Medicine*, 1969, 40, 174-176.
- Ninow, E.H., Cunningham, W.F., & Radcliffe, F.A. Psychophysiological and environmental factors affecting disorientation in naval aircraft accidents. In A.J. Benson (Ed.), *The disorientation incident* (AGARD CP-95 - Part 1). London: Technical Editing and Reproduction Ltd., 1972.
- Nuttall, J.B. The problem of spatial orientation. *Journal of the American Medical Association*, 1958, 166, 431-438.
- O'Connor, P.J. Differential diagnosis of disorientation in flying. *Aerospace Medicine*, 1967, 38, 1155-1160.
- O'Connor, P.J., Lister, J.A., & Rollins, J.W. Results of behavior therapy in flying phobia. In P.J. O'Connor (Ed.), *Clinical psychology and psychiatry of the aerospace operational environment* (AGARD CP-133). London: Technical Editing and Reproduction Ltd., 1973.
- Ornitz, E.M. Vestibular dysfunction in schizophrenia and childhood autism. *Comparative Psychiatry*, 1970, 11, 159-173.
- Parker, D.E., Ritz, L.A., Tubbs, R.L. & Wood, D.L. Effects of sound on the vestibular system (AMRL TR 75-89). Oxford, Ohio: Miami University, 1976.
- Passey, G.E., & Guedry, F.E. Perception of the vertical. II. Adaptation effects in four planes. *Journal of Experimental Psychology*. 1949, 39, 700-707.
- Reason, J.T., & Brand, J.J. *Motion sickness*. London/New York: Academic Press, 1975.
- Reinhardt, R.F., Tucker, G. J., & Haynes, J.M. Aerospace psychiatry and neurology. In *U.S. Naval Flight Surgeon's Manual*. Washington, D.C.: U.S. Government Printing Office, 1968.
- Simpson, C.G. & Lyons, T.G. Giant hand phenomenon. (Abstract) 58th Annual Scientific Medical Meeting of the Aerospace Medical Association, Las Vegas, May 1987.
- Sinha R. Effect of vestibular Coriolis reaction on respiration and blood-flow changes in man. *Aerospace Medicine*, 1968, 39, 837-844.
- Stockwell, C.W., & Guedry, F.E. The effects of semicircular canal stimulation during tilting on the

Vestibular Function

- subsequent perception of the visual vertical. *Acta Otolaryngologica (Stockholm)*, 1970 70, 170-175.
- Takemori, S., & Cohen, B. Loss of visual suppression of vestibular nystagmus after flocculus lesions. *Brain Research*, 1974, 72, 213-224.
- Tjemstrom, O. Alternobaric vertigo. An experimental study in man of vertigo due to atmospheric pressure changes. Thesis, printed in offset, Malmo General Hospital, Malmo, Sweden, 1974.
- Tormes, F.R., & Guedry, F.E. Disorientation phenomena in naval helicopter pilots. *Aviation, Space, and Environmental Medicine*, 1975 46, 387-393.
- Von Bekesy, G. Uber die starke der vibrationsempfindung und ihre objektive messung. *Sonderdruck aus "Akustische Zeits"*, 1940, 5, 113-124.
- Walsh, E.G. Role of the vestibular apparatus in the perception of motion on the parallel swing. *Journal of Physiology (London)*, 1961a, 155, 506-513.
- Walsh, E.G. Sensations aroused by rhythmically repeated linear motion-phase relationships. *Journal of Physiology (London)*, 1961b, 155, 53P-54P.
- Walsh, E.G. The perception of rhythmically repeated linear motion in the horizontal plane. *British Journal of Physiology*, 1962, 53, 439-445.
- Walsh, E.G. The perception of rhythmically repeated linear motion in the vertical plane. *Quarterly Journal of Experimental Physiology*, 1964, 49, 58-65.
- Young, L.R. On visual-vestibular interaction. In *Fifth Symposium on "The Role of the Vestibular Organs in Space Exploration"* (NASA SP-314). Washington, D.C.: U.S. Government Printing Office, 1973.
- Young, L.R., & Meiry, J.L. A revised dynamic otolith model. *Aerospace Medicine*, 1968, 39, 606-608.

CHAPTER 4

SPACE FLIGHT CONSIDERATIONS

Introduction

Manned Space Flight Programs for the 1990's

Medical Standards for Shuttle Astronauts

Physiological Considerations in Space Flight

References and Bibliography

Introduction

The role of the flight surgeon in support of space operations and travel has continued to expand exponentially. Much information has been realized since the onset of manned space flight some three decades ago. While most direct care of Shuttle astronauts remains the bailiwick of National Aeronautics and Space Administration (NASA) physicians, the naval flight surgeon should be cognizant of fundamental physiological changes experienced during Shuttle operations in the event that they were to be involved in astronaut care at auxiliary landing sites, or as the result of an emergency requiring the Shuttle to ditch at sea.

This chapter is not meant to be an exhaustive compendium of space medicine. Rather, it should serve to acquaint operational physicians with characteristics unique to manned space flight. More specific questions should be directed to the physicians at NASA, or retrieved from existing data bases at the Johnson Space Center laboratories in Houston, Texas.

Manned Space Flight Programs for the 1990's

A new vista in manned space flight was reached on 12 April 1981 when the Space Shuttle made its maiden voyage. With it came the ability to extend the time spent in orbit to weeks and months. As conditions associated with space travel cannot be duplicated anywhere else on Earth, plans are underway to build and operate a manned space station early in the next decade. Other plans in the next two decades entail interplanetary travel, potentially years in duration. No longer are these plans the work of our great fictional writers. Therefore, it behooves all personnel associated with or interested in aerospace medicine to acquaint themselves with these programs and the unique biomedical problems associated with microgravitational states.

Medical Standards for Shuttle Astronauts

As mission requirements change, so to do the physiological requirements associated with them. The requirements specified in Table 4-1 are meant to answer basic questions concerning NASA's requirements for each of the four medical classes of astronauts. A more detailed discussion of each category can be found in NASA publications JCS 11569, 12 – 83; JSC 11570, 12 – 83; JSC 11571, 12 – 83; and Class IV criteria updated 12 – 84. Class 1 (pilot) astronauts, Class 2 (mission specialist) astronauts, and Class 3 (payload specialist) astronauts require selection and annual medical recertification. Class 4 space flight participants must be selected and pass medical certification germane to individual mission requirements.

Physiological Considerations in Space Flight

The Neurovestibular System

Some 40 to 50 percent of those who travel in space for any length of time can be expected to experience some form of space motion sickness. It is generally felt to be caused by the lack of gravitational effect on the otolith organ and the semicircular canals. Onset of the symptoms occurs after establishing orbital velocity. Sympathetic symptoms include pallor, flushing, cold sweats, nausea, and emesis. More centralized symptoms include anorexia, lethargy, malaise, headache, confusion, spatial disorientation, anxiety, and depression. The symptoms last from about several hours to four or five days. Postflight vestibular symptoms last up to a week, depending upon the length of time spent in space.

Standard autogenic biofeedback techniques such as those currently employed by the Navy and Air Force to desensitize susceptible aircrew members suffering from air sickness have proven effective in reducing the incidence and severity of the symptoms. Promethazine hydrochloride and ephedrine sulfate (25 mg each PO) or a combination of scopolamine hydrobromide (0.3 mg PO) and dextroamphetamine (5.0 mg PO) have proven to be highly effective in relieving these symptoms. Use and effectiveness varies from one individual to another. Therefore, if one drug or drug combination doesn't work, the flight surgeon should try others until a suitable combination is found. Alternate administration routes (transdermal, intramuscular, etc.) are currently being investigated.

Space Flight Considerations

Table 4-1

NASA Medical Class Standards

Criteria	Class 1 Pilots	Class 2 Mission Specialists	Class 3 Payload Specialists	Class 4 Space Flight Participants
Distant Vision	>20/50 no correction 20/20 O.U. corrected	>20/100 no correction 20/20 O.U. corrected	> 20/40 corrected better eye	correctable >20/40 best eye
Near Vision:	>20/20 uncorrected O.U.	>20/20 uncorrected O.U.	> 20/40 corrected better eye	correctable > 20/40 best eye
Hearing Loss 0.5,1,&2K Hz	30/25/25 each ear	30/25/25 better ear 35/30/30 worse ear	35/30/30 better ear	whisper test 3 ft (aid permitted)
Height	64-76 in	60-76 in	none specified	none specified
Contraction Visual Field	15 degrees	15 degrees	30 degrees	none specified
Phorias ESO EXO Hyper	>15 >8 >2	>15 >8 >2	none specified	none specified
Depth Perception	Verhoeff No Errors	Any Error in 8	none specified	none specified
Color Vision	Pass Farnsworth Lantern	Pass Farnsworth Lantern	none specified	none specified
Blood Pressure	>140/90	>140/90	>150/90 Rx permitted	>160/100 Rx permitted
Radiation Exposure	>5 rem/year	>5 rem/year	none specified	none specified

The Cardiovascular System

Nearly all astronauts experience a cephalad – central fluid shift of 1 to 2 liters during space flight. The fluid shift is generally accompanied by increased heart rates well within the tachycardic range (110-160 BPM). Neither phenomenon is seemingly related to the length of the flight. The major sources for the fluid shifted cephalad comes from the lower extremities and the pelvis. Symptomatology experienced after the shift in fluids includes a feeling of nasal stuffiness, a full feeling in the head, and facial edema. Prominent jugular and temporal veins are also noted. With longer missions, several fluid shifts from cephalad to caudad and vice versa can be expected. These symptoms are generally self – limiting and do not require any type of medical intervention.

These fluid shifts are also accompanied by orthostatic intolerance during the first week of space flight. This is generally followed by postflight syncope. No therapy is required for inflight orthostasis. However, it has been noted that having the astronauts drink 1 liter of normal saline immediately prior to initiation of the landing sequence has reduced the severity of postflight syncope.

Cardiovascular parameters on electrocardiograms, echocardiograms, and vectorcardiograms undergo changes throughout space flight. For a complete discussion of these changes, please refer to Nicogossian (1981). These changes take up to several weeks to return to baseline. Crew members in earlier space programs were noted to experience rare PVC's (numbers above their preflight baseline). Shuttle astronauts have been noted to experience up to 16 PVC's per minute during reentry. The exact extent to which dysrhythmia can be attributed to space flight remains under investigation. Occurrences over baseline should be expected. No fatal dysrhythmias or circulatory collapse have been reported in relation to these dysrhythmias.

Bone and Mineral Metabolism

Both U.S. and Russian data indicate that mineral loss occurs during space flight. This results in the loss of both compact and trabecular bone. Loss of calcium begins about 10 days into space flight. While the rate of loss is slow at first (around 140 mg per day), by 84 days into flight it approaches 300 mg per day. This remains a significant factor in extended missions. Recovery and bone remodeling is gradual after a return to Earth. Time taken to remodel lost bone mass parallels the time spent in space during which it was lost. Recovery is not generally felt to be complete, with trabecular bone possibly being permanently affected.

There are several methods used to counter the adverse bone effects experienced in space flight. First, exercise during space flight has been reported to help reduce bone loss. However, the results are contradictory. Calcium and phosphate dietary supplements have been shown to be efficacious for brief periods of time (short missions). Preflight diets rich in calcium and phosphate are also

Space Flight Considerations

helpful. Fluoride and clodronate disodium (a diphosphonate) have shown promising results in bed – rest simulation models. Artificial gravity systems are under development and show promise especially for the space station. Lastly, electrostimulation of muscle groups has been somewhat helpful in reducing the effects of weightlessness on bone loss.

Hematological and Laboratory Parameters

Significant reductions occur in both the plasma volume and the red blood cell mass. Plasma volume decreases soon after the onset of weightlessness, remains low throughout the flight, and generally returns to baseline in about one to two weeks after landing. An early reduction in red blood cell mass also occurs. It seems to plateau around the 60th day of weightlessness and returns to baseline about two to three weeks postflight. The reticulocyte count is noted to be decreased postflight on most missions, returning to normal approximately three to four week after return to Earth. On longer missions (> 55 days), the reticulocyte count is higher than normal at the three week postflight point, and remains elevated for a number of weeks thereafter. Erythropoietin levels decrease around 24 hours after launch and continue to decrease during and after the flight.

For a list of other useful laboratory parameters, see Tables 4 - 2 and 4 - 3.

Waste Management

Personal hygiene and waste management prove to be a challenge in space travel. Prompt removal of all biohazards is paramount in assuring the health of the crew throughout the flight. While earlier manned flights used devices that required contact with the individual, present programs incorporate air flow for the collection and separation of excreta. Urine is generally expelled from the spacecraft, while fecal material and food remnants are freeze dried and returned to Earth on the Shuttle for final disposal. For future interplanetary missions, systems will have to be designed to reclaim water from urine, feces, and unused foodstuffs.

A workable shower system was developed for the Skylab program. However, a suitable model for the Shuttle program remains in the developmental phase. As current missions are generally short in nature, the only method for bathing is via a handwashing device and sponge bath. Longer missions will necessarily require a more thorough means for bathing without compromising water availability.

Special Toxicological Hazards

There are many toxic substances found aboard the Space Shuttle. Table 4 - 4 is an abbreviated

list of some of the more commonly encountered substances aboard as well as treatment guidelines for acute exposure to them.

Table 4-2

Selected Immunological and Hematological Values

VALUE	TREND
Total White Blood Cell Count	Increased
Eosinophil Count	Decreased
Neutrophil Count	Increased
T Lymphocyte Count	Decreased
T Lymphocyte Function	Decreased
Immunoglobulin G *	Decreased (short flight) Increased (long flight)
Immunoglobulin A *	Decreased (short flight) Increased (long flight)
C3 & C4 *	Increased

* Values return to baseline in about 3 weeks.

Space Flight Considerations

Table 4-3

Selected Endocrine Laboratory Parameters

VALUE	IN-FLIGHT TREND	POST-FLIGHT TREND
Adrenocorticotrophic Hormone	Increased	Increased
Atrial Natriuretic Factor	Increased, Then Decreased	Increased, Then Decreased
Anti-Diuretic Hormone	Increased	Normal
Aldosterone	Decreased	Increased
Angiotensin I	Decreased	Increased
Cortisol	Decreased	Increased
High Density Lipoprotein		Markedly Decreased
Growth Hormone		No Change
Insulin		Increased
T3		No Change
T4		Increased
Thyroid Stimulating Hormone		Increased
Urine Catecholamines		Increased

Circadian Rhythm Alterations

Space travel is particularly disruptive to entrained circadian rhythms. Not only does the “new environment” of space and microgravity serve to disrupt sleep – wake cycles; but, there is a substantial lack of zeitgebers (natural cues) to readjust biological clocks once they uncouple. Because of the lack of zeitgebers, most crew members revert back to a 25 hour schedule. Experience has shown that for Shuttle crew, it is probably best to keep them on their Earth – bound sleep – wake cycles where possible. This further serves to minimize the impact of other disruptive environmental changes. Light-dark cycles occur every 100 minutes in the shuttle crew members.

U.S. Naval Flight Surgeon's Manual

Therefore, artificial day – night cycles have to be developed and maintained throughout the mission to assure adequate crew rest. While ultrashort acting benzodiazepines have been found to be of some use in combatting jet lag, a paucity of information exists concerning their role in space flight.

Table 4-4
Common Shuttle Hazards and Treatment

Agent	Color	Smell	Category	Symptoms	Treatment
Ammonia	colorless	pungent	mucous membrane irritant	conjunctivitis eyelid edema coughing/dyspnea nausea/emesis pneumonitis burns	flush area with H ₂ O O ₂ , ACLS
Freon	colorless	odorless	asphyxiant, CNS depressant cardiac sensitizer	arrhythmia mental status changes, dermatitis	remove from source, O ₂ , ACLS
Hydrazine	colorless	like ammonia	oxidant convulsant hepatotoxin hemolysis carcinogen	convulsion skin burn hepatitis nephritis death	remove from source, anticonvulsant med Vit B6
Nitrogen Tetroxide	yellow brown red	pungent	oxidant explosive	yellow skin stains, burn, blindness, pulmonary edema	remove from source, O ₂ ACLS
Isopropyl Alcohol	colorless	disagreeable odor	irritant CNS depressant	nausea, coma	O ₂ , IV ACLS
Mercury	silvery metal	metallic taste	systemic poison	ataxia, nausea, renal damage	remove from source
Lithium Hydroxide	white crystal	pungent	reducing agent irritant	severe mucous membrane irritant	flush, O ₂

*Adapted from Table 19-3, Nicogossian, A.E., *Space Physiology and Medicine*.

Space Flight Considerations

References and Bibliography

- Bungo, M.W., & Johnson, P.C. Cardiovascular examinations and observations of deconditioning during the space shuttle orbital flight test program. *Aviation Space and Environmental Medicine*, 1983, 54, 1001-1004.
- Bungo, M.W., & Johnson, P.C. Cardiovascular deconditioning during space flight and the use of saline as a countermeasure to orthostatic intolerance. *Aviation Space and Environmental Medicine*, 1985, 56, 985-990.
- Bungo, M.W., & Goldwater, D. J., et.al. Echocardiographic evaluation of space shuttle crew members. *Journal of Applied Physiology*, 1987, 62, 278-283.
- Calvin, M., & Gazenko, O.G. *Foundations of space biology*, (NASA SP-374). Washington, DC: US Government Printing Office, 1975.
- Cann, C. Determination of spine mineral density using computerized tomography: A report. Washington, DC: XII US/USSR Joint Working Group Meeting on Space Biology and Medicine, 1981.
- Coleman, M.E. *Atmospheric contamination control, space station medical science concepts* (NASA TM - 58255). Houston: Lyndon B. Johnson Space Center, 1984.
- DeHart, R.L. *Fundamentals of Aerospace Medicine*. Philadelphia: Lea and Febiger, 1985.
- Gazenko, O.G., Grigor'yev, A.I., & Natochin, Y.V. Fluid electrolyte homeostasis and weightlessness. *Space Biology and Aerospace Medicine*, 1980, 14, 1-11.
- Graybiel, A., Wood, C.D. et.al. Human assay of anti-motion sickness drugs. *Aviation Space and Environmental Medicine*, 1975 46, 1107-1118.
- Henry, W.L., Epstein, S.E., et.al. *Effect of prolonged space flight on cardiac function and dimensions, biomedical results from Skylab* (NASA SP - 377). Washington, DC: U.S. Government Printing Office, 1977.
- Homick, J.L., Kohl, R.L., et.al. Transdermal scopolamine in the prevention of motion sickness: Evaluation of the time course of efficacy. *Aviation Space and Environmental Medicine*, 1983, 54, 994-1000.
- Hoffler, G.W. Cardiovascular studies of U.S. space crews: An overview and perspective, cardiovascular flow dynamics and measurements. In Hwang, N.H.C. & Normann, N.A. (Eds.), Baltimore: 1977.
- Hoffler, G.W., & Johnson, R.L. *Apollo flight crew evaluations, biomedical results of Apollo* (NASA SP-368). Washington, DC: U.S. Government Printing Office, 1975.
- Hoffler, J.L., Johnson, R.L., Nicogossian, A.E., et.al. *Vectorcardiographic results from Skylab medical experiment M092: Lower body negative pressure, biomedical results from Skylab* (NASA SP - 377), Washington, DC: U.S. Government Printing Office, 1977.
- Leach, C.S. An overview of the endocrine and metabolic changes in manned space flight. *Acta Astronautica* 1981, 8, 977-986.
- Leach, C.S. Biochemistry and endocrinology results, the Apollo-Soyuz test project medical report (NASA SP-411). In Nicogossian, A.E. (Ed.), Washington, DC: U.S. Government Printing Office, 1977.
- Money, K.E. Motion Sickness. *Physiology Review* 1970, 50, 1-39.
- Nicogossian, A.E. *Space physiology and medicine*. Philadelphia: Lea and Febiger, 1989.
- Nicogossian, A.E., LaPinta, C.K., et.al. Crew health: The Apollo-Soyuz test project medical report (NASA SP -411). In Nicogossian, A.E. (Ed.), Springfield, VA: National Technical Information Service. 1977.

U.S. Naval Flight Surgeon's Manual

- Proctor, N.H., Hughes, J.P., & Fischman, M.L. *Chemical hazards of the workplace*. New York: J.B. Lippincott, 1988.
- Reason, J.T., & Brand, J.J. *Motion sickness*. London: Academic Press, 1975.
- Reason, J.T. & Graybiel, A. An attempt to measure the degree of adaptation produced by differing amounts of coriolis vestibular stimulation in the slow rotation room (NAM1 - 1084, NASA Order R - 93). Pensacola: Naval Aerospace Medical Institute, 1969.
- Smith, R.F., Stanton, K., *et.al.* *Vectocardiographic changes during extended space flight: Observations at rest and during exercise biomedical results from Skylab* (NASA SP - 377). Washington, DC: U.S. Government Printing Office, 1977.
- Stupakov, G.P. Artificial gravity as a means of preventing atrophic skeletal changes. *Space Biology Aerospace Medicine*, 1981, 15, 88-90.
- Vogel, J.M., & Whittle, M.W. Bone mineral changes: The second manned Skylab mission. *Aviation Space and Environmental Medicine*, 1976, 47, 396-400.

CHAPTER 5

INTERNAL MEDICINE

Section I: Cardiology

- Introduction
- Basics of Electrocardiography
- Axis
- Complexes and Intervals
- Normal Electrocardiographic Variants
- Abnormalities of Conduction
- Arrhythmias
- Acquired and Congenital Structural Heart Disease
- Endocarditis Prophylaxis
- Atherosclerotic Heart Disease
- Hypertension

Section II: Gastroenterology

- Esophageal Reflux and Hiatal Hernia
- Peptic Ulcer Disease
- Inflammatory Bowel Disease
- Alcoholic Liver Disease

Section III: Hematology

- Anemias - An Overview
- Hemoglobinopathies

Section IV: Metabolic Disorders

- Adrenal Disorders
- Thyroid Disorders

Section IV: Metabolic Disorders (*Continued*)

- Disorders of Glucose Metabolism
- Hyperlipidemias
- Obesity

Section V: Pulmonary Disease

- Pulmonary Function Testing
- Aviation Effects on Pulmonary Function
- Asthma
- Spontaneous Pneumothorax
- Sarcoidosis
- Pulmonary Emboli
- Airway Bums

Section VI: Infectious Disease

- Viral Disease
- Tuberculosis
- Malaria
- Amebiasis
- Traveler's Diarrhea

Section VII: Renal Disease

- Urinary Tract Infection
- Hematuria/Proteinuria
- Nephrolithiasis

Section VIII: Malignancy

- References and Bibliography

SECTION 1: CARDIOLOGY

Introduction

The electrocardiogram (ECG) is an invaluable diagnostic aid and clinical tool. It is not meant to replace a thorough review of a patient's medical history nor a carefully conducted physical ex-

amination. Rather, the standard 12-lead ECG provides additional information to amplify the basic cardiovascular examination. The ECG, if normal, offers no guarantee that a physician is dealing with a completely normal cardiovascular system. Conversely, the abnormal ECG does not necessarily imply immediate and unalterable catastrophe in a patient.

In the majority of instances, a flight surgeon will be dealing with healthy, young adult males. It is important, therefore, that the normal ECG be recognized in its various forms. The following review stresses the identification and evaluation of the normal tracing. In so doing, it is hoped that the identification of abnormal tracings can be aided.

Basics of Electrocardiography

In order to determine whether a tracing is normal or abnormal, a clear knowledge of lead placement (Figure 5-1), electrocardiogram components (Figure 5-2), and normal variants is necessary. A definite and systematic approach quite similar to the preflight checklist used in naval aviation should be adopted in the interpretation of any electrocardiogram.

The first step is to scan the ECG tracing for basic items of information and organization. Patient identification, including name, rank and serial number, should be on the tracing. Also included must be relevant clinical information, such as age, sex, and current medication. The tracing should present all 12 leads, with proper standardization in all leads and a 1.0 millivolt (10 millimeter (mm)) deflection. This initial scan should also attempt to detect any 60 hertz interference due to improper grounding, evidence of muscle tremor or similar artifacts, or a wandering baseline.

The ECG next should be examined for regularity of rhythm. If there is an essential regularity, is it sinus, junctional, or idioventricular? With an irregular rhythm, is there a definite pattern to the irregularity? Are there beats grouped in pairs? Are there dropped beats? Is there an erratic irregularity?

Finally, the initial scan should assess the rate of heart beat. This can be done if one understands standard recording procedures. The electrocardiogram is inscribed on a background of one millimeter squares with each fifth line thicker than the intervening four. The horizontal span between the thickened lines is 0.20 seconds (1/5 second). Thus, the time elapsing between each mm square (at a standard speed of 25 mm/second) is 0.04 seconds, the basic interval for timing electrocardiographic events. Also, there are three-second marginal markers on most ECG paper; knowing this, the simplest system to estimate rate is by multiplying the number of cycles in six seconds by ten. If the tracing is not long enough to allow this, the number of fifths of a second between cycles can be determined, and this number then divided into 300.

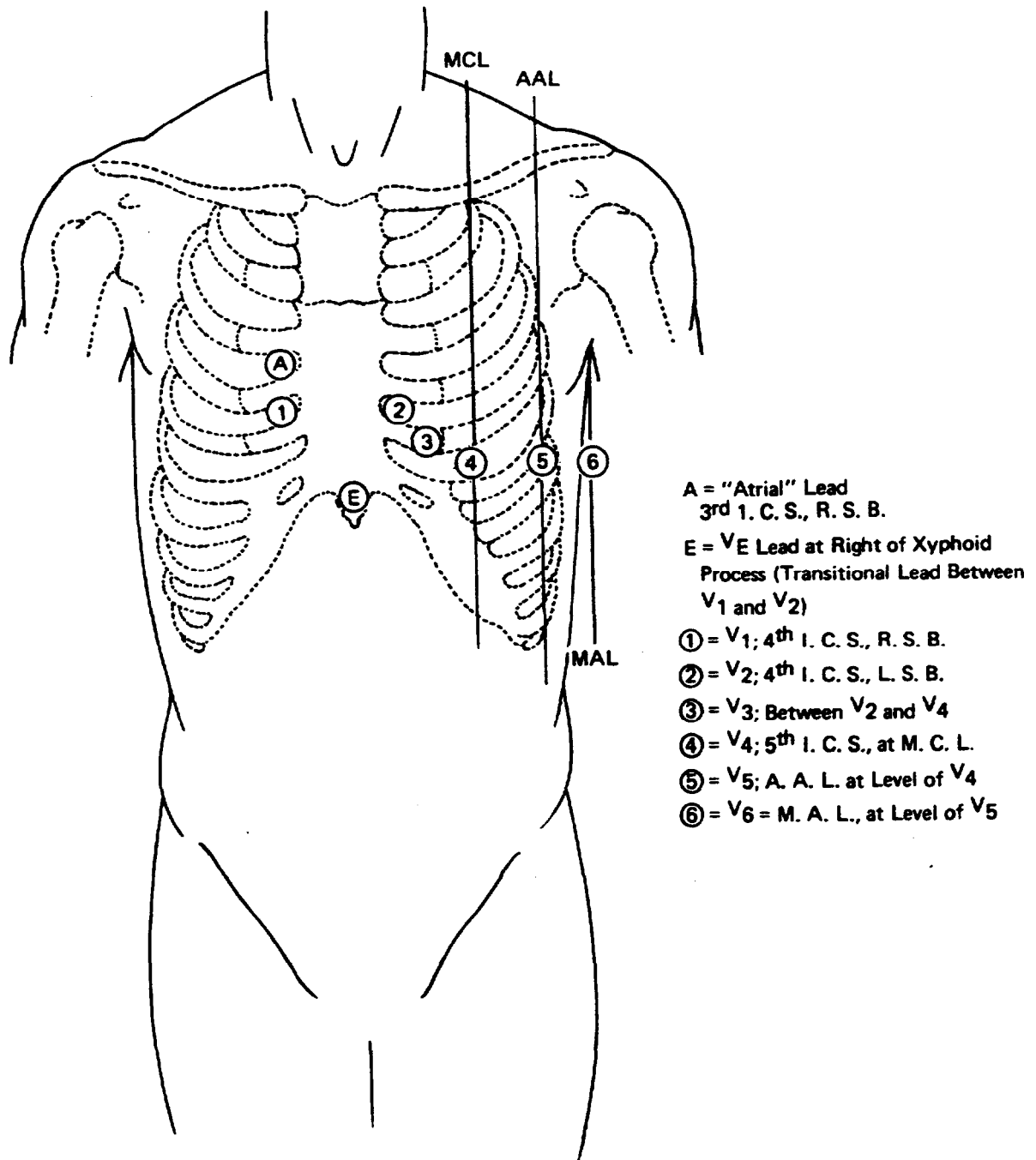

Figure 5-1. Precordial lead placement for horizontal plane leads.

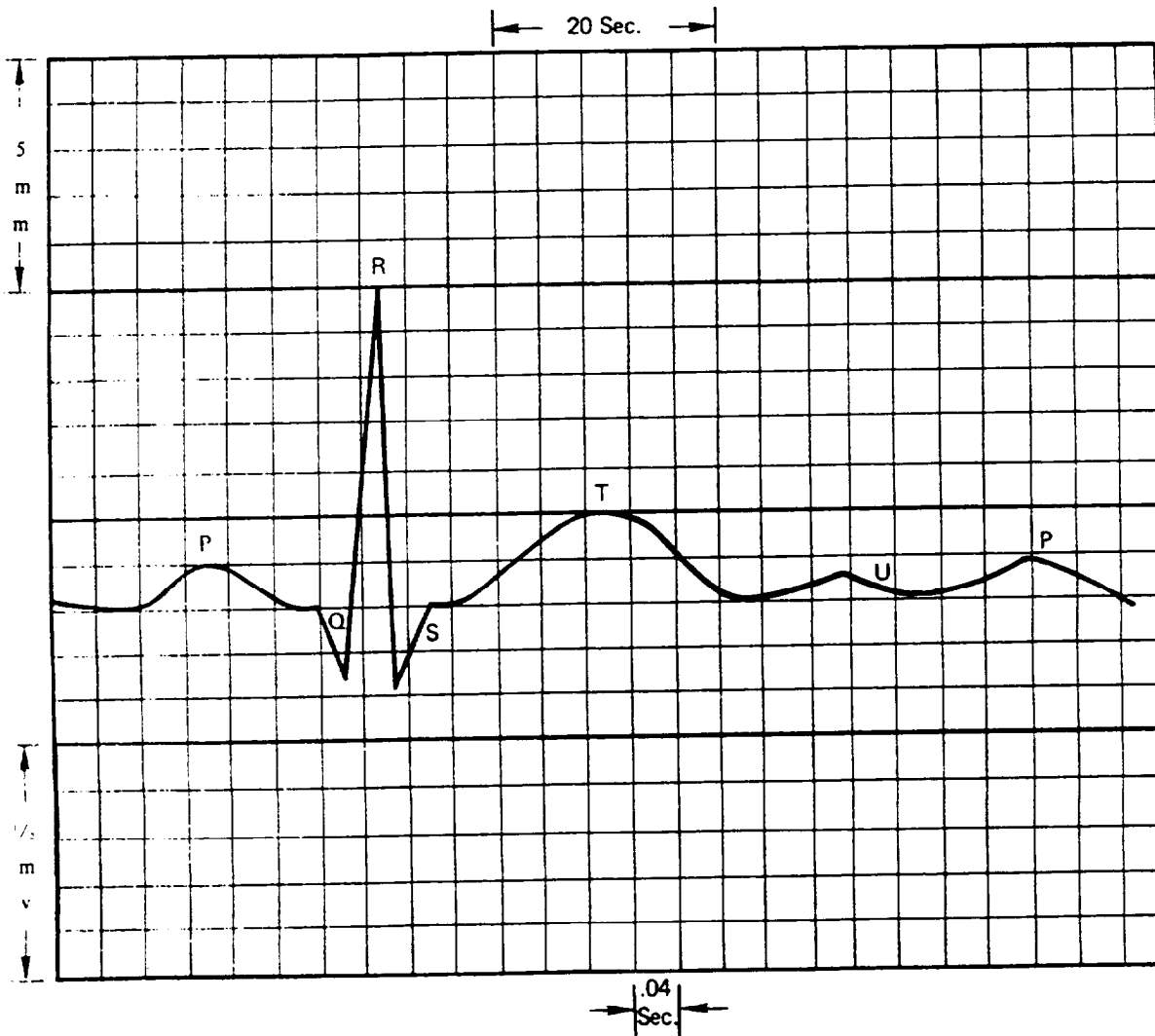

Figure 5-2. Basic electrocardiographic measurements and complexes.

Axis

The orientation of the heart's electrical activity in the frontal plane may be expressed in terms of the "axis" or "heart position". To calculate the numerical axis, one must know the Hexaxial Reference System, as presented in Figures 5-3 and 5-4. The electrical impulse writes the largest deflection on the lead whose line of derivation is parallel to its path. It writes the smallest deflection on the lead perpendicular to its path. To calculate the frontal plane axis, it is easiest to look initially for the lead with the smallest deflection (i.e., the one most nearly isoelectric). The axis of

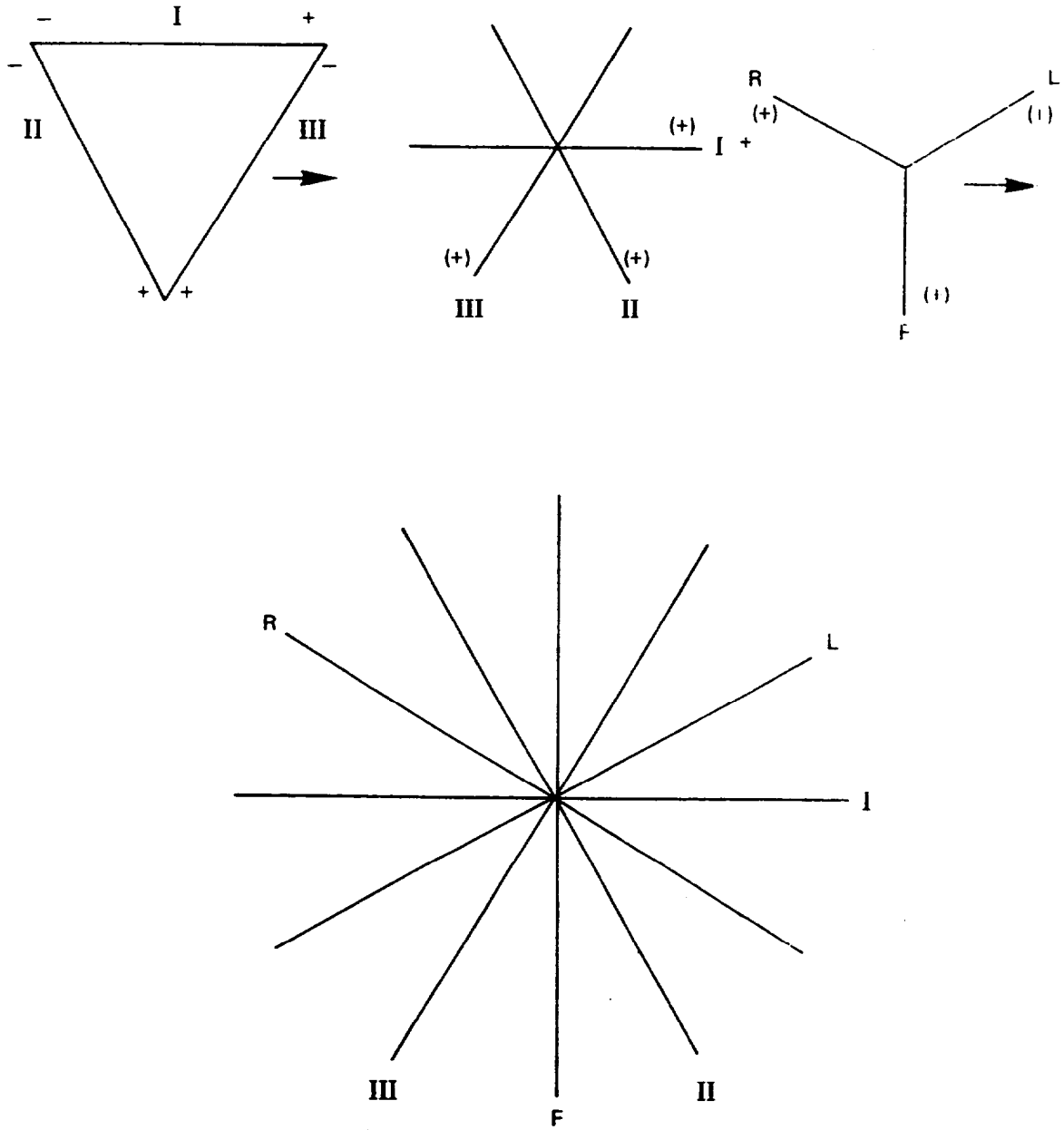

Figure 5-3. Development of hexaxial reference system from standard bipolar and augmented limb leads.

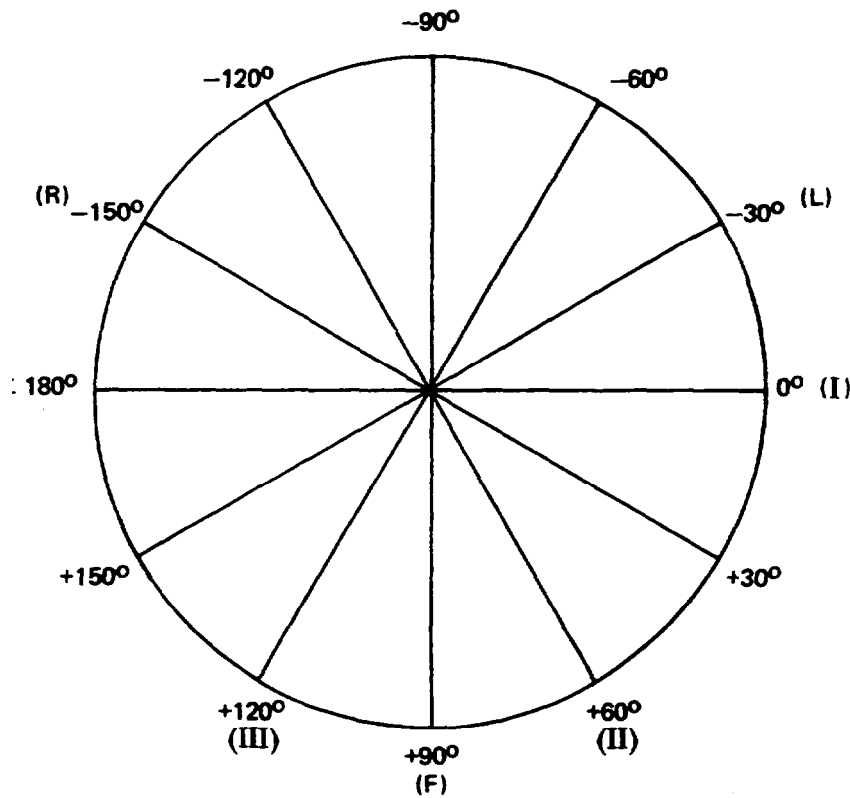

Figure 5-4. Hexaxial reference system.

the heart is perpendicular, or nearly so, to this lead and lies parallel to the lead with the largest deflection.

The normal axis of the heart is generally accepted as being between 0° and $+90^{\circ}$. There are differences of opinion, however, among various authorities. The New York Heart Association accepts $+30^{\circ}$ to $+60^{\circ}$ as normal. The meaning of various axis deviations is shown in Table 5-1.

The principles and methods used in determining axis deviation also may be applied in examining P- and T-waves. Here, it is best to plot the QRS and T-axis and to symbolize them as long and short arrows, respectively. Note especially that the QRS-T angle should normally be no greater than 60° .

Table 5-2 presents etiologies for both right and left axis deviation.

Internal Medicine

Table 5-1

Axis Deviation Shifts

Classification	Extent (Degrees)
Slight Left Axis Deviation	0 to -30 (Probably WNL)
Slight Right Axis Deviation	90 to 120 (Probably WNL)
Left Axis Deviation	0 to -90
Right Axis Deviation	90 to 180
Marked Left Axis Deviation	-30 to -90
Marked Right Axis Deviation	120 to 180
Extreme Left Axis Deviation	-90 to -120
Extreme Right Axis Deviation	180 to -150

Table 5-2

Etiologies for Axis Deviation

Right	Left
Normal Variant	Normal Variant
Mechanical Shifts - Inspiration, Emphysema	Mechanical Shifts - Expiration, Elevated Diaphragm from Ascites, Tumor, Pregnancy, etc.
Right ventricular hypertrophy	Left ventricular hypertrophy*
Right bundle branch block'	Left bundle branch block*
Left posterior hemiblock	Left anterior hemiblock*
Dextrocardia	Wolff-Parkinson-White
Left ventricular ectopy	Right ventricular ectopy

*Axis deviation may or may not be present in these instances.
(Marriott, 1972).

Complexes and Intervals

Electrocardiogram complexes are groupings within an overall ECG tracing which indicate specific cardiac activity. Complexes which are displaced both above and below baseline are biphasic (or diphasic). Complexes showing equal excursions above and below baseline are termed equiphasic. Leads in which equiphasic complexes are seen are called isoelectric.

P-Wave

The P-wave is an electrocardiographic representation of atrial depolarization. In a sinus mechanism, the P-wave is the initial wave of the ECG complex.

The normal P-wave is less than 0.11 seconds in duration, is less than 2.5 mm in height, and can show notching of up to 0.04 seconds. The mean P-wave axis normally is 0° to $+90^{\circ}$ in the frontal plane. P-waves normally are upright in I, II, and aVF leads, inverted in aVR, and variable in III, aVL, and V leads. Normal variance includes the so-called coronary sinus rhythm with inversion of P-waves in II, III and aVF (frontal plane axis of -45° to -75°) and normal P-wave configuration in the V leads. Another normal variant is the left atrial rhythm, showing P-wave inversion in II, III, aVF, and V_2 or $V_3 - V_6$.

P-R Interval and Segment

The P-R interval is measured from the onset of the P-wave to the onset of the QRS complex. It measures the time required for the electrical impulse to travel from the S-A node to the ventricle. The normal range is from 0.12 to 0.20 seconds however, it is generally shorter in children than in adults. The P-R interval may exceed 0.20 seconds in some normal individuals (i.e., well-conditioned young adults with a high degree of vagal tone who show normalization of the P-R interval during exercise).

The P-R segment is defined as the interval after cessation of P-wave activity to the onset of the QRS complex. Normally, it is isoelectric.

QRS Complex

This is the most important ECG complex, in that it represents ventricular activation (depolarization). Here proper terminology is essential. If the initial deflection is negative to the baseline, it is a Q-wave. A negative deflection following the R-wave is an S-wave. Subsequent positive deflections are termed R', R'', etc., with subsequent negative deflections termed S' and S''.

Internal Medicine

If a QRS complex is excessively positive, points at the beginning and end of the complex are labeled Q and S, respectively. An entirely negative wave is called a QS wave.

In an inspection of a QRS complex, there are six features of importance which should be examined:

1. Duration
2. Amplitude
3. Presence (and Duration) of Q-waves
4. Electrical Axis
5. Precordial Transition Zone
6. Timing of "Intrinsicoid Deflections" in V_1 and V_6

Duration. The normal duration of the QRS complex is 0.05 to 0.10 seconds. Occasionally, duration intervals exceeding these criteria, in either direction, are encountered and may be normal. These durations are based on measurement by standard leads. Use of precordial leads may result in slightly longer durations.

Amplitude. The minimal frontal plane QRS amplitude is 5 mm. Minimal amplitudes using precordial leads are V_1, V_6 - 5mm, V_2, V_5 - 7mm, and V_3, V_4 - 9mm. Normal upper limits are more difficult to establish, although frontal plane QRS amplitudes of up to 20 to 30 mm are seen in lead II in some normal individuals. Maximum amplitudes with precordial leads may be 25 to 30 mm, and on occasion even to 35 mm.

Q-waves. This feature of the complex is important, but often it is difficult to assess. Salient features to observe with Q-waves are the width of the Q, leads in which the Q's appear, and the clinical setting. Size is important, with a diminutive Q of 1 mm having possible significance that a QS of 10 mm does not have. A narrow Q in I, aVL, aVP, and V_5 - V_6 is normal, and the absence of such a Q-wave may be of significance. QS or QR complexes are normal in aVR, while a QS may normally be found in III, V_1 , or V_2 . Duration of the Q-wave is considered normal up to 0.03 seconds.

Electrical Axis. The electrical axis of the QRS complex is of consequence and, as noted earlier, should form an angle with the T-wave no greater than 60° .

Precordial Transition Zone. This refers to the horizontal plane rotation. The direction of rotation is specified as viewed from the inferior cardiac surface looking upward from the diaphragm. The normal transition zone is V_3 - V_4 . A clockwise rotation is a shift of the horizontal plane axis to the left or a delay in the typical LV pattern beyond V_5 . Counterclockwise rotation shows displacement to the right, resulting in a typical LV pattern as early as V_2 .

Intrinsicoid Deflection. Since direct epicardial lead placement is impractical, indirect precordial leads must be used to produce patterns of precordial activity. In these clinical leads, the downward deflection is the analogue of the intrinsic deflection (i.e., the so-called intrinsicoid deflection). The intrinsicoid deflection records the instant at which the cardiac muscle immediately below a unipolar electrode has been completely depolarized. Figure 5-5 depicts the sequence of ventricular activation and the resultant complexes obtained from RV and LV unipolar electrodes. The intrinsicoid deflection (i.e., the peak of the R, should be reached in V_1 within 0.02 seconds (0.03 seconds maximally) and in V_5 , V_6 within 0.04 seconds.

ST Segment. The ST segment is that part of the tracing immediately following the QRS with the "take-off" point called the "J-junction". The ST segment should be observed for its level relative to the baseline and for its shape. Normally, the ST segment may be initially elevated 1 mm in the standard leads and 2 mm in precordial leads, although in some instances of early depolarization up to 4 mm may be observed. The ST segment should not be depressed beyond 0.5 mm.

The contour of the ST segment is a gentle, upward slope which blends into the proximal limb of the T-wave.

T-Wave. This wave represents the recovery period of the ventricle or ventricular repolarization. The T-wave normally is upright in I and II and in V leads over the LV. It is inverted in aVR and is variable in other leads. Also, the T-wave normally is upright in aVL and aVF if the QRS is greater than 5 mm. The QRS-T angle, as noted earlier; should not exceed 60° in the frontal plane.

In precordial leads, the tendency to inversion of the T in early leads diminishes rapidly with age. In some normal athletic young adults, the T-wave inversion occasionally extends beyond V_4 . Generally, the shape is rounded with some loss of symmetry. T-waves usually are not larger than 5 mm in standard leads or 10 mm in precordial leads.

QT Duration. This feature of a tracing measures the total electromechanical duration of ventricular systole. It varies with heart rate, sex and age. Generally, the QT interval is less than one-half the preceding R-R interval. At heart rates below 65 beats per minute (bpm), the QT falls further below this value. At bpm above 90 to 100, it often exceeds one-half the R-R interval.

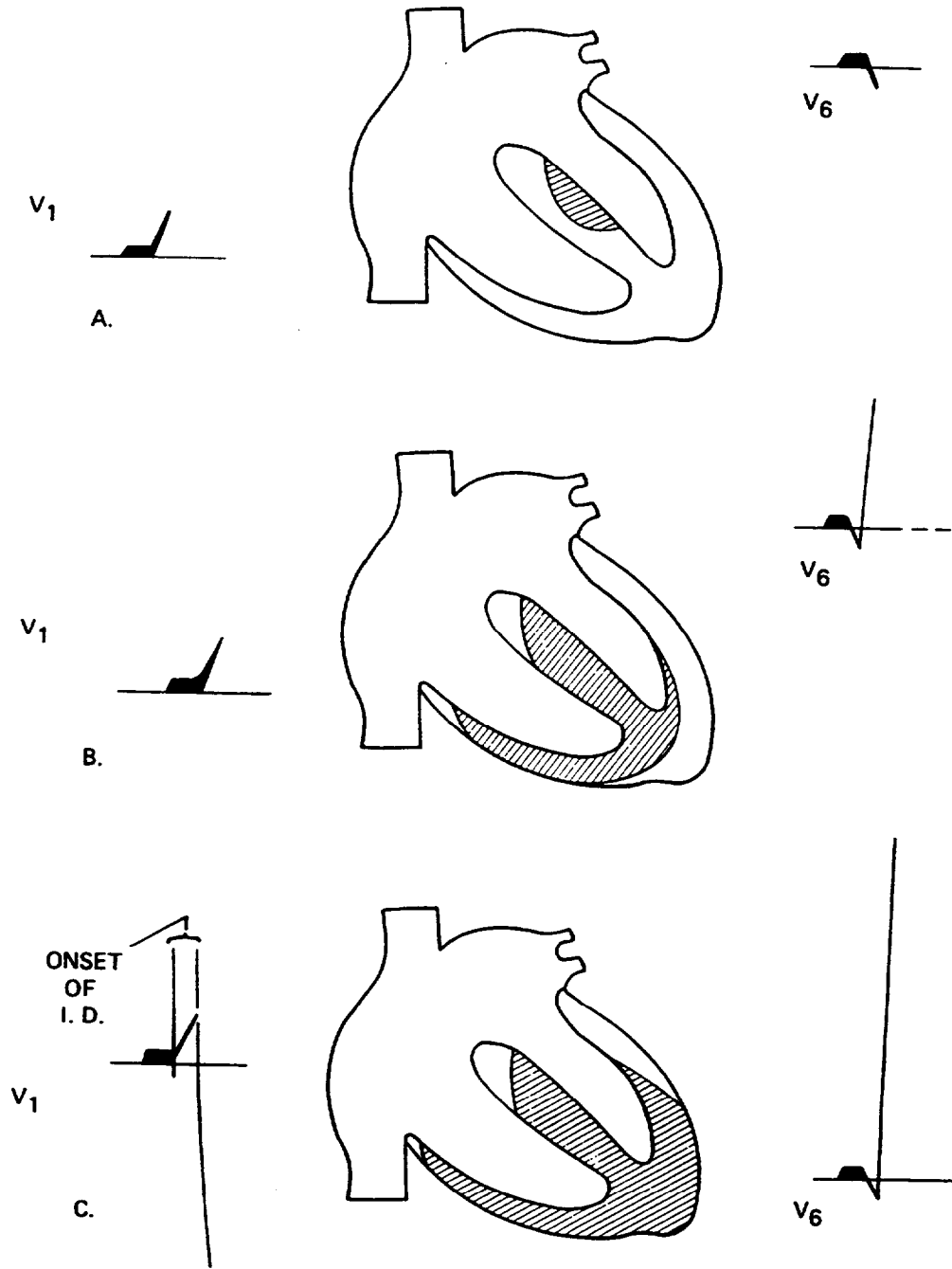

Figure 5-5. Sequence of ventricular activation.

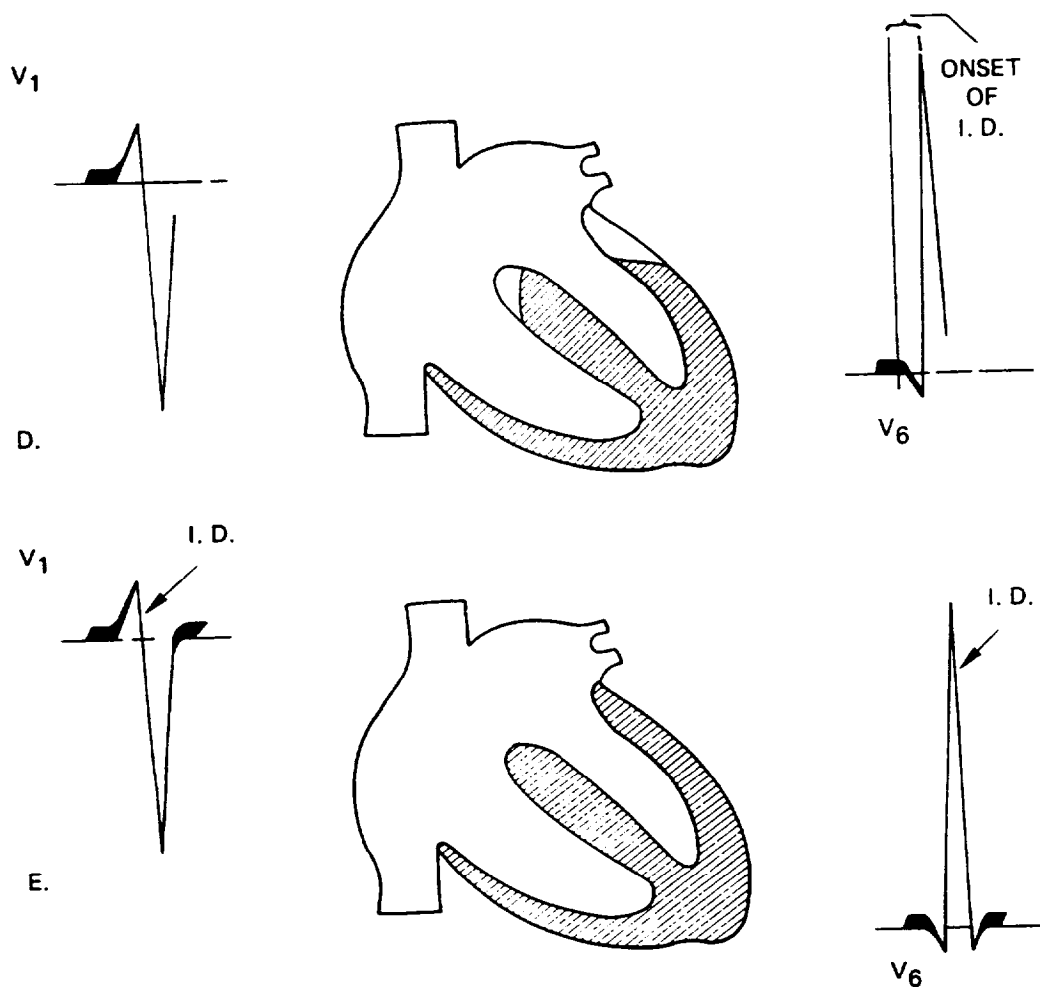

Figure 5-5 (Continued). Sequence of ventricular activation.

U-Wave. This wave represents a ventricular after-potential. Normally, it is smaller than the preceding T-wave. Its normal polarity is in the same direction as the T-wave. The U-wave is best discerned in V_3 .

Normal Electrocardiographic Variants

ECG's performed on a young, athletic, and generally healthy population, such as aviators, often show variant patterns which experience has shown are not associated with underlying heart disease. Common normal variants are listed.

Sinus Bradycardia

Sinus bradycardia is characterized by an otherwise normal ECG with a rate less than 60 beats/minute. The heart rate should increase appropriately with exercise.

Sinus Arrhythmia

Sinus arrhythmia is distinguished by constant P-R intervals with varying R-R intervals.

Abnormal P Axis

With an abnormal P axis (“coronary sinus rhythm”) atrial depolarization arises from an ectopic focus, resulting in inverted P-waves in the inferior leads.

Early Repolarization

Early repolarization is a normal variant of the ST segment which is very common in the young adult age group of all races. It is seen most commonly in males but is also found in females. The most common configuration is an elevation of the J-point takeoff and a concave upward ST elevation in V₃-V₅, I and aVL although all leads can be affected (ST depressions in a VR are sometimes seen). T-waves are usually peaked but can occasionally be inverted.

Pseudo-LVH

Pseudo-LVH is distinguished by large S waves in V₁-V₂ and large R waves in V₄-V₆ which meet voltage criteria for LVH in an otherwise normal ECG. Echocardiographic measurements have consistently shown normal left ventricular size in these patients. Left ventricular hypertrophy is very difficult to diagnose in this population by the commonly applied voltage criteria for LVH.

S₁ S₂, S₃, Pattern

The S₁, S₂, S₃ pattern is characterized by S waves in leads I, II, and III, a QRS duration between 0.10 and 0.11 seconds) and frequently an interventricular conduction delay noted in V₁. Vectorcardiographic analysis of this pattern reveals a terminal right-sided, superoposterior conduction delay. The standard ECG often shows an ambiguous axis or left axis in the frontal plane.

Follow-up of over 50,000 ECG tracings at the Naval Aerospace Medical Institute (NAMI) has

failed to demonstrate any defects or disability from this pattern and it is therefore considered a normal variant.

Incomplete Right Bundle Branch Block

Normally the last part of the myocardium to depolarize is the right ventricular outflow tract. There are few Purkinje fibers in this area and transmission is slow across the muscle fibers. In young people this area, called the crista supraventricularis, may be prominent and therefore, its depolarization may appear prominent or be delayed. The resultant "crista pattern" shows an R' in V₁ and a deep, late S wave in V₅ and V₆. The configuration resembles right bundle branch block (RBBB) but its width should not exceed .10 seconds. When this pattern is combined with right axis deviation, which is common in this age group, it may even suggest RVH. Only the physical exam will separate the normal from the abnormal in these situations. If exam and history are normal, no further evaluation is required and the ECG may be interpreted as normal.

Abnormalities of Conduction

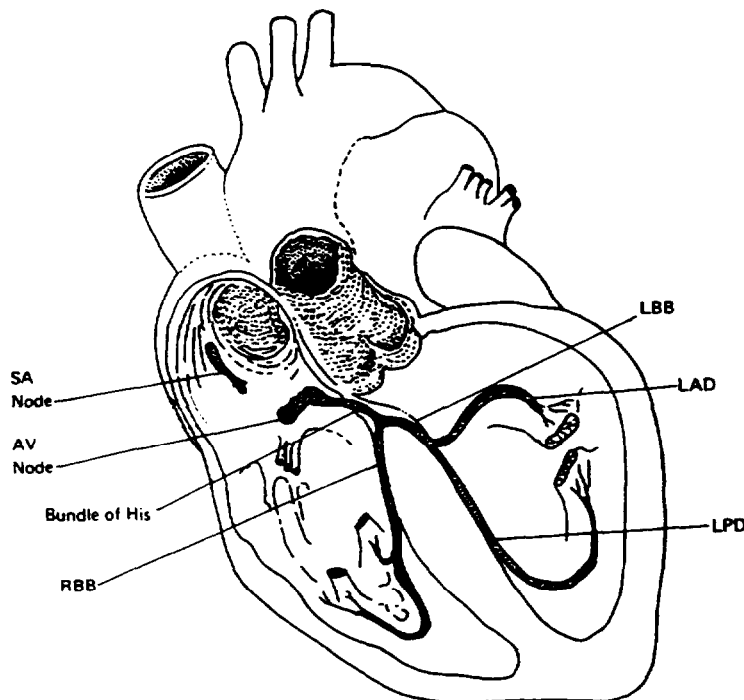

Figure 5-6. Cardiac conduction system.

Internal Medicine

The heart not only is capable of initiating its own rhythmic depolarization but also has specialized neuromuscular tissue capable of conducting the depolarization wave throughout the cardiac muscle. From the S-A node (Figure 5-6), the depolarization wave spreads throughout the atria via three internodal tracts. These are the anterior (Bachman), the middle (Wenckebach), and the posterior (Thore). Between these tracts, interconnecting fibers merge just proximal to the A-V node. Not all fibers enter the A-V node, however. Some fibers bypass it and enter the conduction system distal to this node.

The A-V node is located on the endocardial surface of the right side of the atrial septum. Here, the impulse is normally delayed for approximately 0.07 seconds. The impulse then passes into the His bundle, located on the endocardial surface of the right side of the atrial septum distal to the A-V node. The common (His) bundle subdivides in the membranous portion of the ventricular septum into a right bundle branch and a left bundle branch. The left bundle branch further subdivides into the anterosuperior division and the posteroinferior division. After traversing the right and left bundles, the impulse passes into multiple small branches (the Purkinje system) and into the ventricular myocardium.

The principal classes of conduction abnormality are presented in Table 5-3. The following sections describe these classes in some detail.

Table 5-3

Principal Conduction Abnormalities

Incomplete A-V block
1° A-V block
2° A-V block
Mobitz I
Mobitz II
High degree-A-V block
Complete A-V block
Right bundle branch block
Left bundle branch block
Left anterior hemiblock
Left posterior hemiblock
Complete left bundle branch block
Bilateral bundle branch block
Pre-excitation [Wolff-Parkinson-White]

First Degree A-V Block

A first degree A-V block is caused by a delay in conduction through the AV node and is manifested by a P-R interval greater than 0.21 seconds. It may be seen in a variety of clinical conditions including rheumatic fever, myocarditis, chronic ischemic heart disease and infarction, certain drugs (ie., digitalis, quinidine, propranolol and slow calcium channel blocking agents), hyperthyroidism, adrenocortical insufficiency, hypoxia, infiltrative cardiomyopathies, and various congenital heart lesions. First degree A-V block may also result from increased vagal tone on the A-V node and represent a normal variant in physically conditioned individuals. It is present in up to one and a half percent of normal young individuals and up to 33 percent of trained athletes.

In a normal heart, the P-R interval shortens with an increase in heart rate and thus may be distinguished from pathological P-R prolongation. Individuals showing a physiological response (P-R shortening to within normal limits) with exercise are physically qualified for duty involving flying.

Second Degree A-V Block

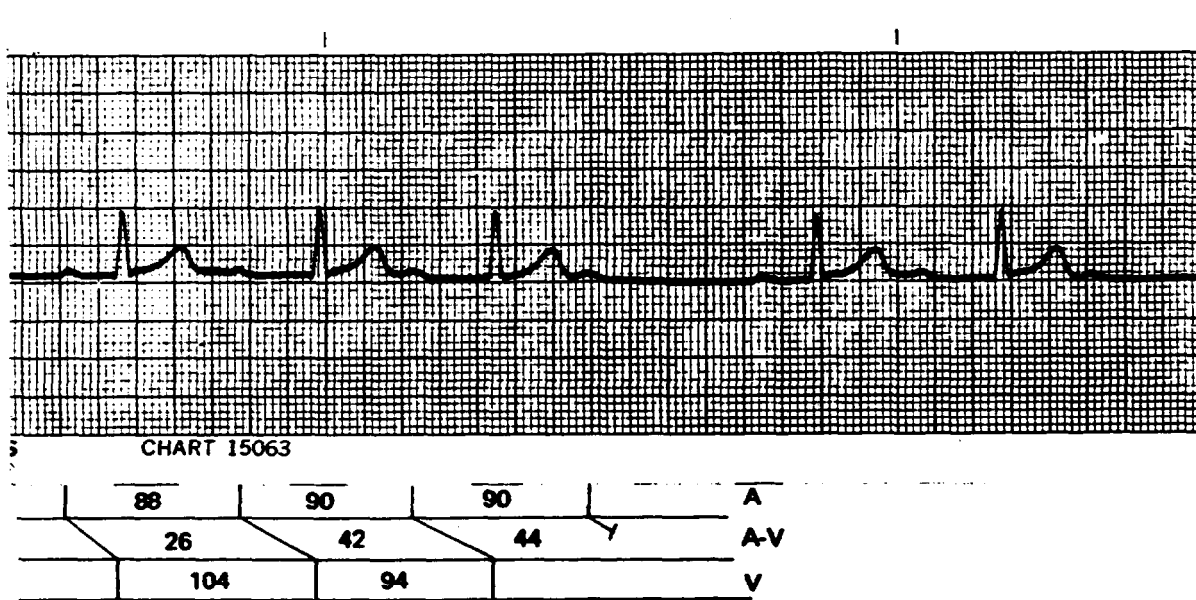

Figure 5-7. 2° A-V block (Wenckebach).

Mobitz Type I. Mobitz I (Wenckebach) is a progressive AV block manifested by a sequential increase in the PR interval until a beat is completely blocked (Figure 5-7). In the aviation setting,

as with first degree AV block, it is usually caused by a high degree of vagal tone in normal, conditioned individuals, for example, 23 percent of trained athletes. However, many of the conditions associated with pathological first degree AV block may also cause Wenckebach. Aviation personnel showing the Mobitz I pattern should undergo a noninvasive workup including a graded exercise test, 24-hour ambulatory ECG monitoring, and an echocardiogram. They are considered qualified for flying if no underlying heart disease is found and no further conduction abnormalities or arrhythmias are discovered.

Mobitz Type II. This abnormality is characterized by a constant PR interval with some beats completely blocked (Figure 5-8). It is frequently associated with bundle branch blocks, where the dropped beat represents intermittent blocking of the other bundle. It may be caused by the same underlying disorders as first degree AV block and Mobitz I, but is much more likely to represent underlying heart disease and is therefore disqualifying for all flying duties.

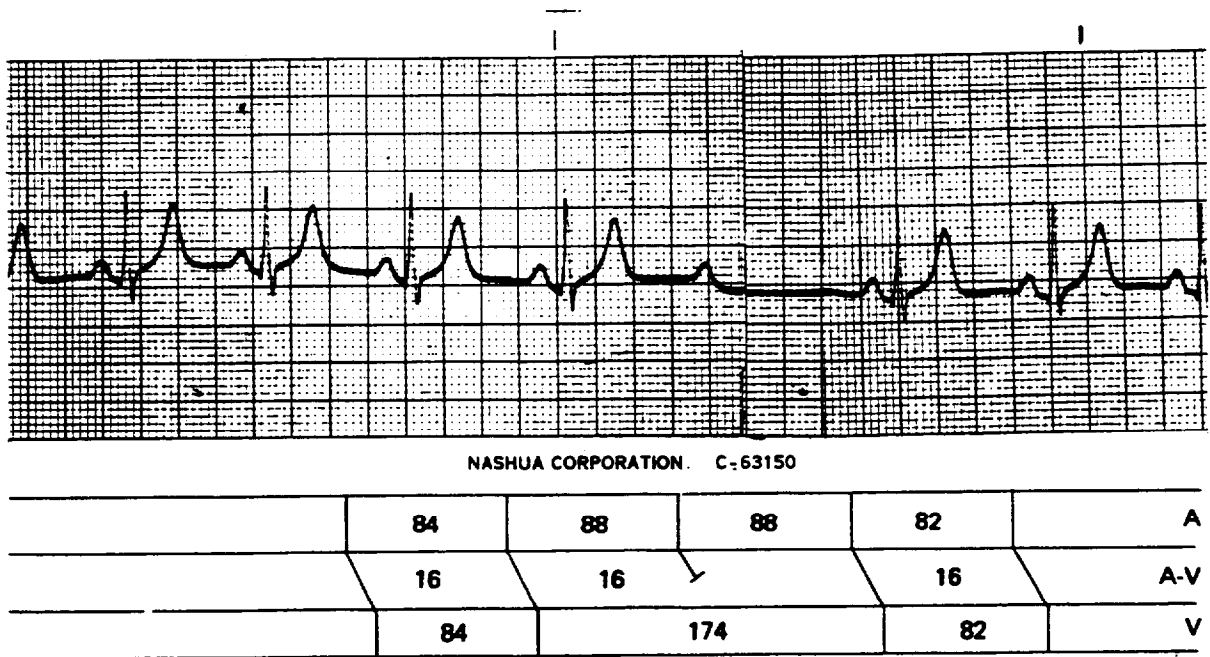

Figure 5-8. Mobitz II, 2° A-V block.

Third Degree A-V Block

With a third degree A-V block (complete heart block), the atria and ventricles beat independently of one another; no atrial beats are conducted to the ventricles (Figure 5-9). Always

indicative of serious cardiac disease, complete heart block requires pacemaker therapy and is, of course, disqualifying for aviation.

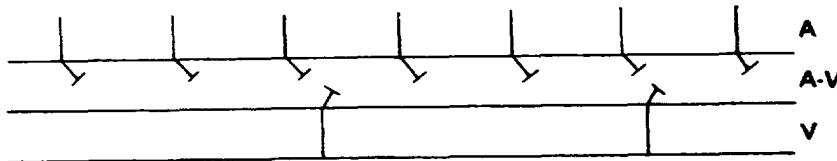
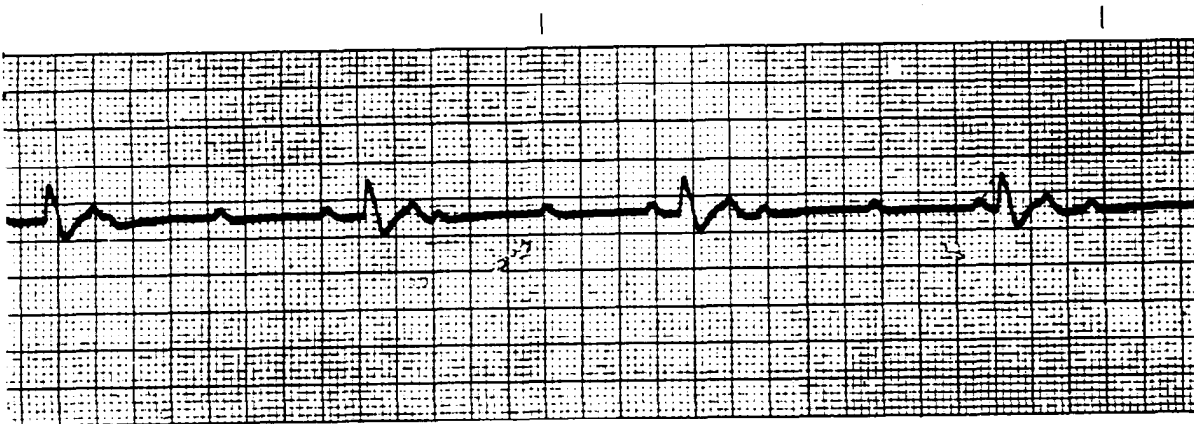
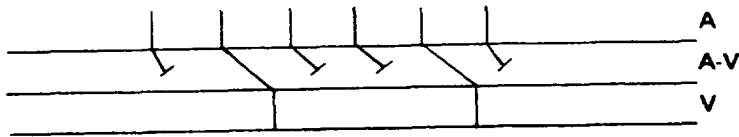
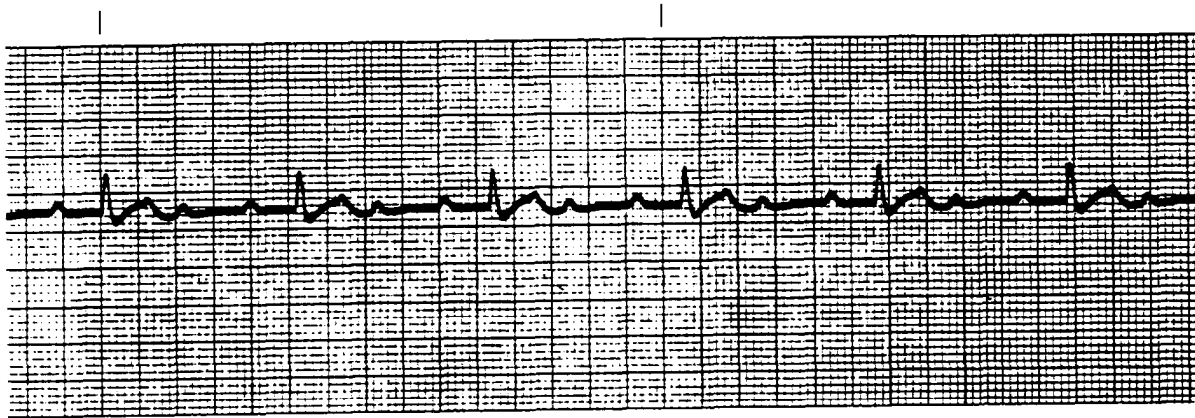

Figure 5-9. High degree A-V block. 3° A-V block.

Right Bundle Branch Block

The sequence of ventricular activation in right bundle branch block (RBBB) is shown in Figure 5-10, with the resulting recordings presented in Figure 5-11. Initial septal activation is normal; thus, an initial small R-wave will be recorded in V_1 , as will a small Q-wave in V_6 . Since the right bundle branch is blocked, the impulse will travel down the left bundle branch into the LV, resulting in an S-wave in V_1 and an R-wave in V_6 . RV depolarization follows, as the LV activation wave envelopes the RV free wave, resulting in an R' in V_1 and an S-wave in V_6 . The QRS duration is 0.11 to 0.12 seconds or greater (Figure 5-10). Right bundle branch block may result from advancing coronary artery disease, pulmonary hypertension (from various causes), inflammatory or infiltrative diseases of the myocardium, or congenital lesions involving the septum. It may also be found in about 0.2 to 0.6 percent of individuals without evidence of heart disease. Extensive evaluation of 394 USAF aircrewmembers with an acquired RBBB, including cardiac catheterization and electrophysiological study of the conduction system, found 94 percent with no evidence of any underlying heart disease.

If a noninvasive workup, including echocardiogram, Holter monitor, and stress testing, fails to demonstrate any cardiac disease or arrhythmias, aviation personnel with RBBB are considered physically qualified.

Left Bundle Branch Block

The sequence of ventricular activation in left branch block (LBBB) is shown in Figure 5-12, with the corresponding recording presented in Figure 5-13. Septal activation begins from right to left, giving rise to a small Q-wave in V_1 and an initial small R-wave in V_6 . Since the left bundle branch is blocked, RV activation proceeds normally, giving rise to an R-wave in V_1 and an S-wave in V_6 . Delayed LV activation begins as the impulse passes into the LV, giving rise to an S-wave in V_1 and an R-wave in V_6 . The QRS duration is 0.12 seconds or longer.

Left bundle branch block, although occasionally seen in normal individuals, is more likely than RBBB to be associated with underlying heart disease including coronary artery disease, cardiomyopathies, acute myocarditis, hypertension, and extensive calcification of the aortic annulus. Extensive workup and extended close followup of individuals with acquired LBBB finds about 70 percent with no evidence of underlying heart disease. Thirty percent, however, are found to have a significant problem, usually coronary artery disease (18 percent) or a cardiomyopathy (6.5 percent). Designated aviators are grounded and must undergo an extensive cardiac workup, including echocardiography, coronary arteriography, and radionuclide scanning prior to consideration for a waiver to resume flying. If waived, annual cardiology followup, including echocardiography, is required.

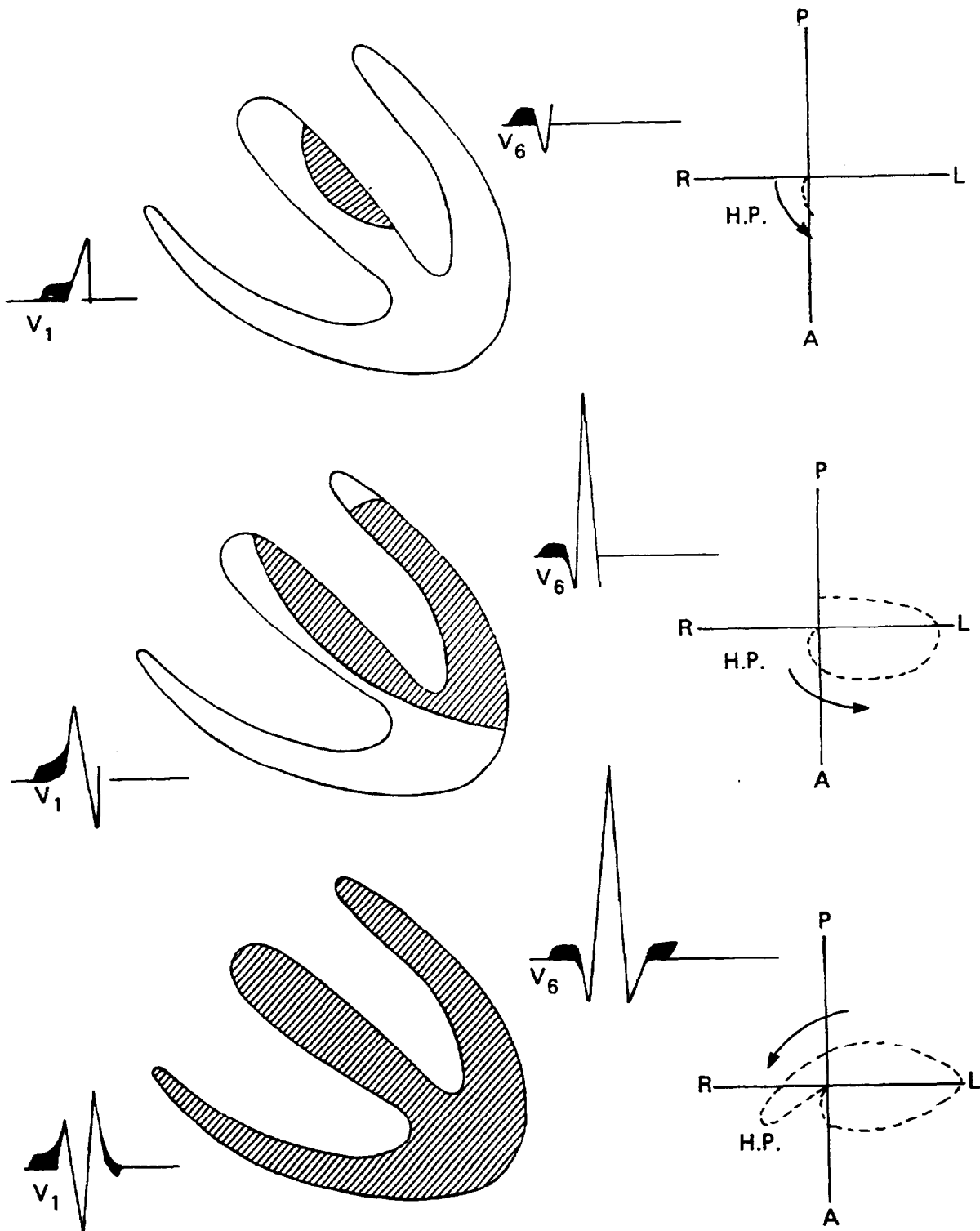

Figure 5-10. Sequence of ventricular activation in right bundle branch block.

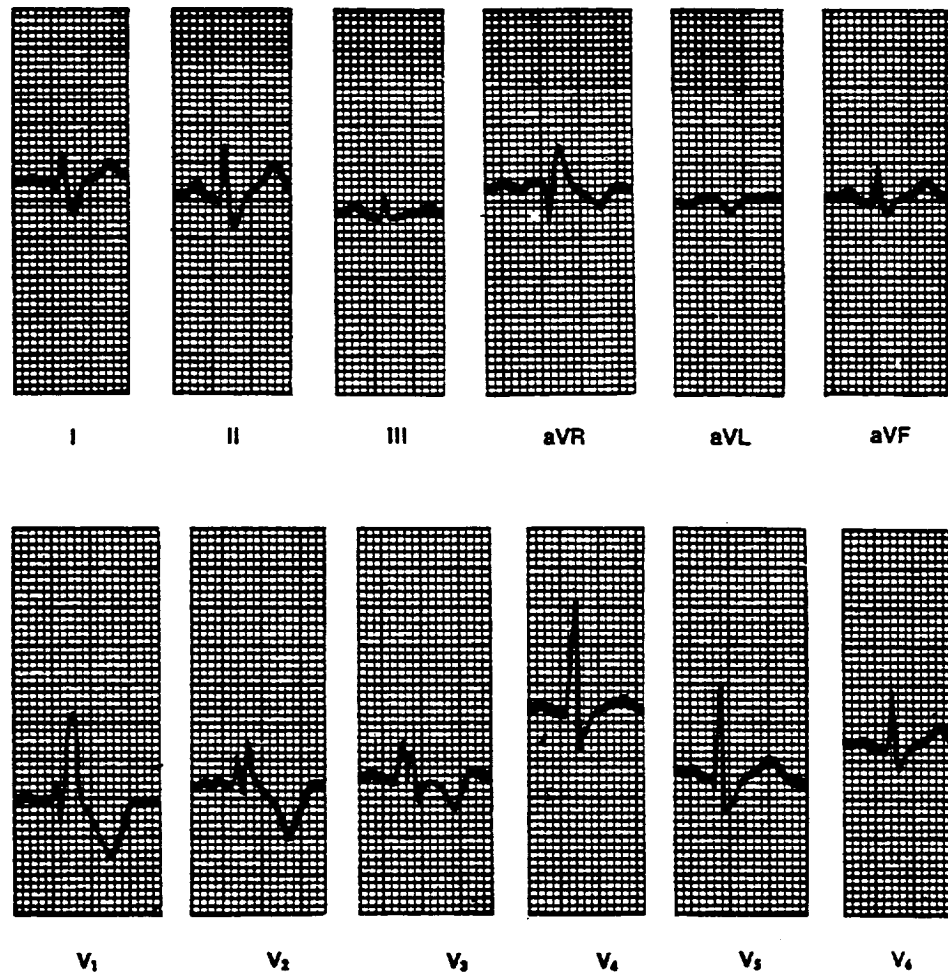

Figure 5-11. Complete right bundle branch block.

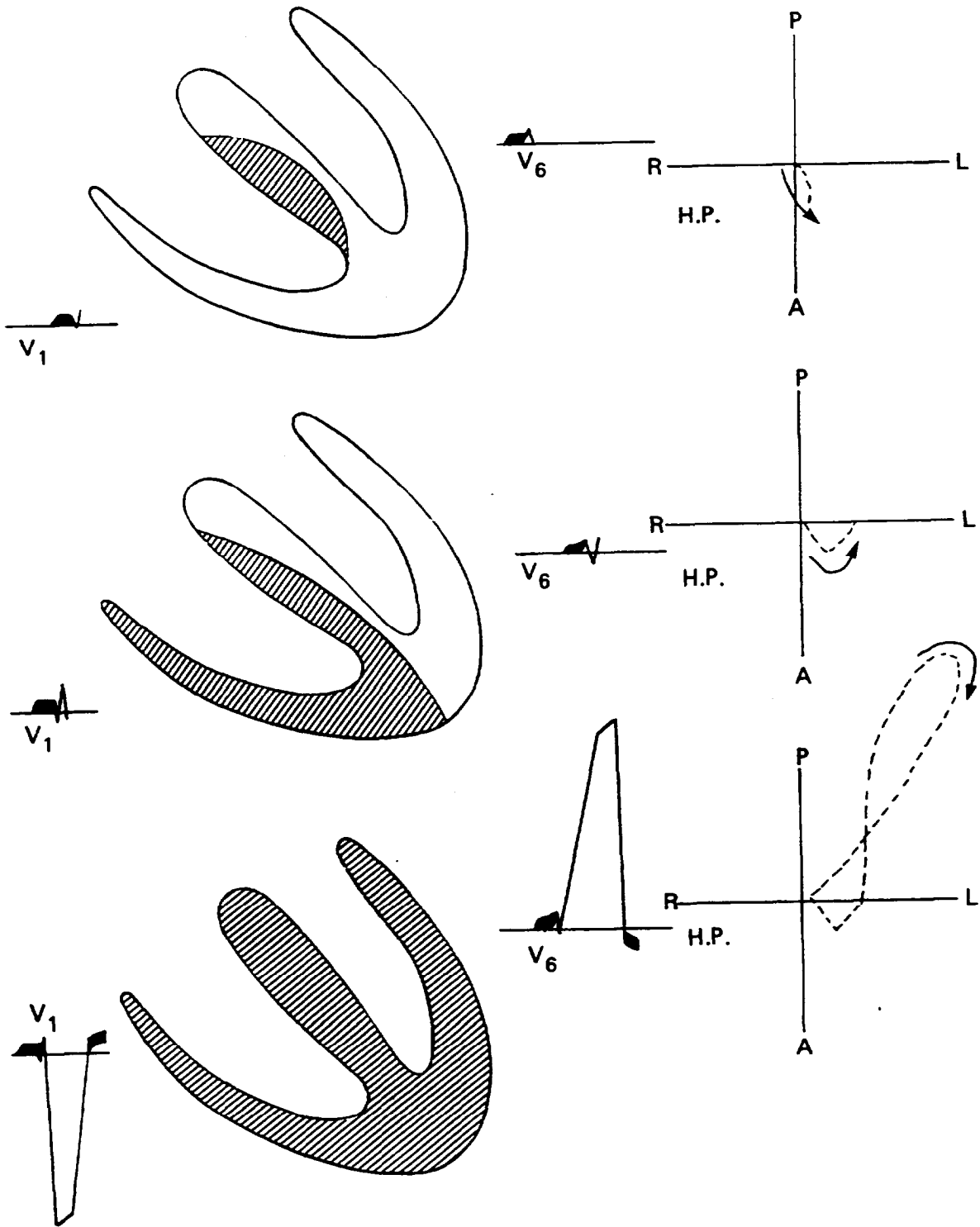

Figure 5-12. Sequence of ventricular activation in left bundle branch block.

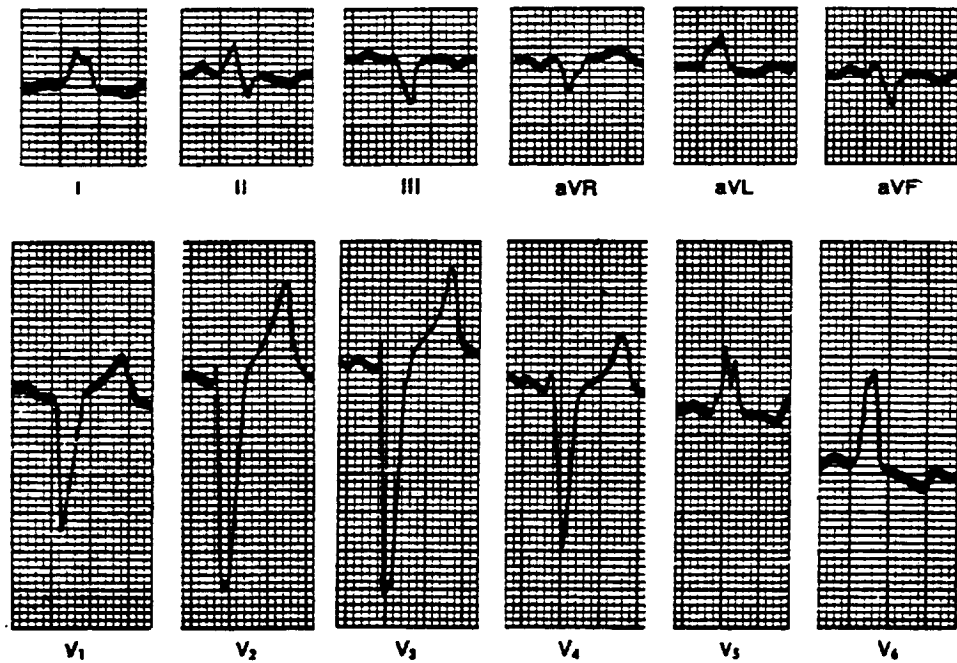
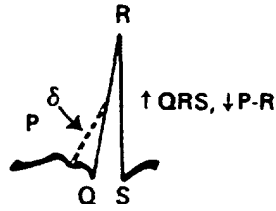

Figure 5-13. Complete left bundle branch block.

Preexcitation Syndromes

Preexcitation results from early activation of the ventricles from AV conduction over atrial ventricular by-pass tracts.

Wolff-Parkinson- White Syndrome. The Wolff-Parkinson-White (WPW) syndrome, perhaps best known of the preexcitation syndromes, occurs in about one percent of the population and is characterized by a short P-R interval and wide QRS and delta waves (Figure 5-14). Up to 40 percent of individuals with WPW have arrhythmias, including paroxysmal supraventricular tachycardias and atrial fibrillation. The PSVT's occurring in WPW are usually (95 percent) conducted in an antegrade direction down the AV node and retrograde up the accessory pathway, resulting in a narrow QRS tachycardia indistinguishable from PSVT in an individual without WPW. In the remaining 5 percent, antegrade conduction down the accessory pathway causes a wide complex tachycardia that can resemble ventricular tachycardia. Atrial fibrillation is occasionally associated with high degrees of AV antegrade conduction down the accessory pathway resulting in ventricular rates of over 300, a potentially lethal arrhythmia. A WPW ECG pattern is disqualifying for entry into aviation. However, a waiver may be granted on a case by case basis for those candidates who exhibit normal electrophysiologic studies and who are clinically asymptomatic. Designated personnel may receive waivers if, by history, exercise stress testing, and 24-hour ambulatory ECG monitoring, there is no evidence of any tachyarrhythmias.



Comparison between normal QRS complex and that in Wolff-Parkinson-White.

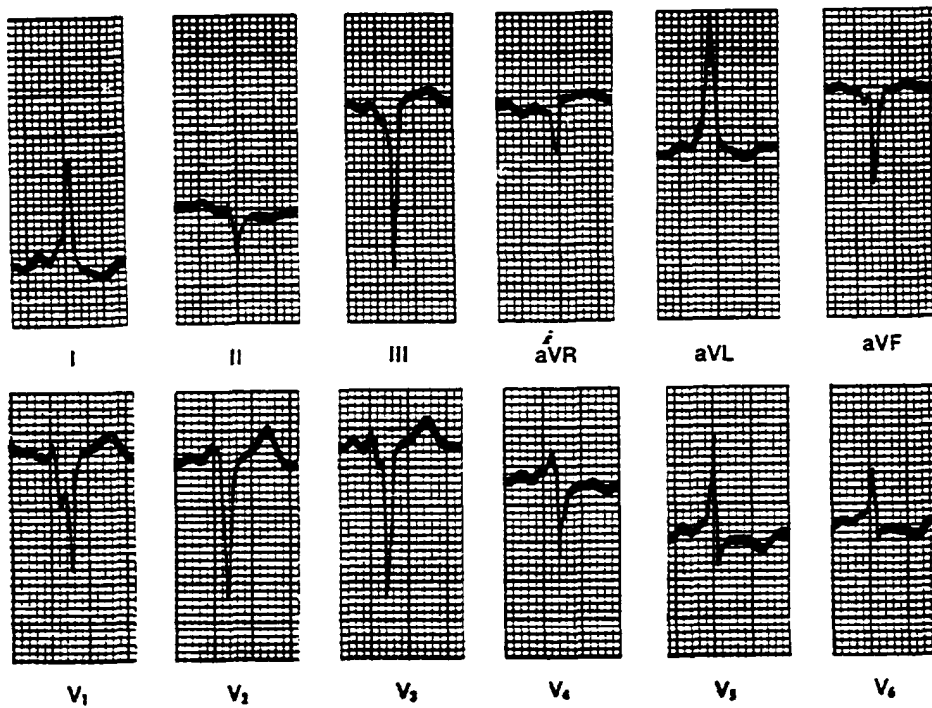

Figure 5-14. Wolff-Parkinson-White.

Other Preexcitation Syndromes. The Lown-Ganong-Levine (LGL) syndrome and other short P-R, normal QRS preexcitation syndromes are associated with tachyarrhythmias to a lesser extent than the WPW syndrome. Aviation candidates with a short PR interval are found qualified if the history, exercise stress test, and 24-hour ambulatory electrocardiogram are negative for arrhythmias.

Arrhythmias

Sinus Tachycardia

Sinus tachycardia, defined as a heart rate over 100 with a normal, stable, P-QRS relationship, is usually a normal physiological response to some underlying stress such as exercise, fever, hypovolemia, thyrotoxicosis, anemia, hypoxia, anxiety, congestive heart failure, pulmonary embolism, pain, or myocardial infarction. Less commonly, it is caused by reentry within the SA node (paroxysmal sinus tachycardia) or by either abnormally high sympathetic tone or abnormally low vagal tone (chronic nonparoxysmal sinus tachycardia).

Persistent heart rates over 100 (supine) or 110 (standing) are disqualifying.

Premature Atrial Contractions

Premature atrial contractions (PAC's) are seen as early P waves that may be abnormally configured; PR intervals that may be short, normal, or long; and, QRS complexes that are usually normal, but may be aberrantly conducted if they occur early enough and find part of the bundle branch system still refractory. PAC's are very common in healthy individuals (e.g., 78 percent of 55 year old males) and are commonly associated with anxiety, fatigue, and the use of caffeine, nicotine, and alcohol. They are also caused by structural heart disease, especially those causing atrial enlargement, such as mitral stenosis and cor pulmonale.

PAC's are not disqualifying in the absence of underlying heart disease.

Premature Ventricular Contractions

Premature ventricular contractions (PVC's) are wide (>0.12 second), bizarre shaped QRS complexes arising from ectopic foci in the ventricles. They are not associated with P waves, and usually result in full compensatory pauses, since the SA node is not reset and the next P wave finds the conduction system still refractory and is therefore not conducted. They may arise from one ectopic focus (uniform) or several (multiform) and may occur in repetitive patterns, such as bigeminy (every other beat is a PVC), trigeminy (every third beat), etc. Three or more PVC's in succession constitutes ventricular tachycardia (see below).

PVC's are very common, even in normal individuals (up to 50 percent), with the incidence increasing with age. They are frequently asymptomatic, but may cause palpitations. The clinical significance of PVC's depends entirely on the presence or absence of underlying heart disease. In-

dividuals without underlying heart disease do not appear to be at an increased risk for malignant arrhythmias.

In and of themselves, PVC's are not disqualifying. Frequent or multiform ventricular ectopy should be evaluated by a noninvasive workup, including a 24 hour Holter monitor, graded exercise test, and an echocardiogram. Asymptomatic individuals without evidence of underlying heart disease or ventricular tachycardia, and with normal exercise tolerance tests, are qualified for all flying duties, including acceptance for flight training.

Supraventricular Tachycardia

Paroxysmal Supraventricular Tachycardia. Paroxysmal supraventricular tachycardia (PSVT's) are regular, usually narrow QRS complex tachycardias with rates generally between 180 and 200 (Figure 5-15). The abnormal P waves are usually buried within the QRS complex. Most PSVT's are caused by reentry within the AV node (60-90 percent), but may also be caused by reentry within the SA node (paroxysmal sinus tachycardia), atrial-ventricular bypass tracts (Wolff-Parkinson-White Syndrome, up to 30 percent), Lown-Ganong-Levine Syndrome, and ectopic atrial pacemakers.

Most episodes of PSVT occur in otherwise healthy individuals, where smoking, caffeine, fatigue, emotional stress, and especially alcohol may be precipitating factors. They are also associated with coronary artery disease, rheumatic heart disease, hypertension, thyrotoxicosis, and, as noted above, Wolff-Parkinson-White Syndrome.

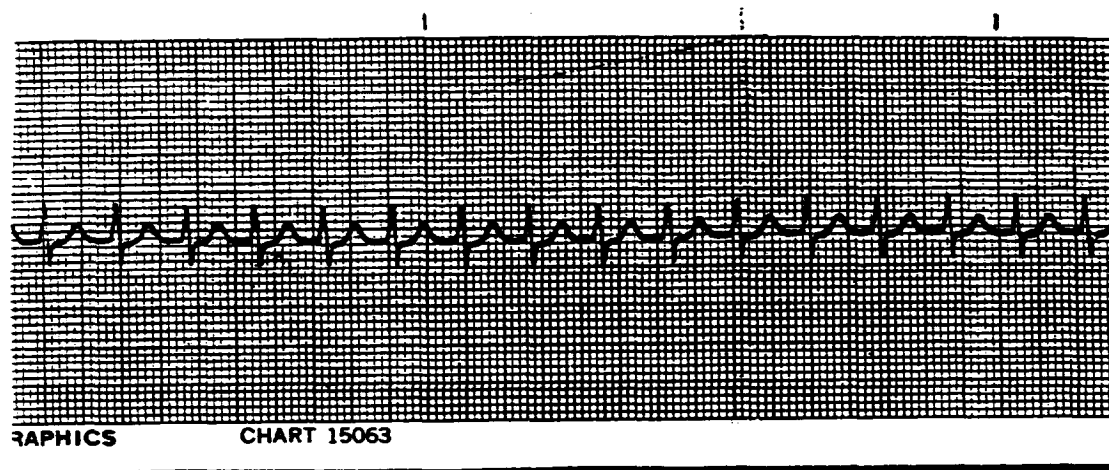

Figure 5-15. Paroxysmal supraventricular tachycardia (PSVT).

Internal Medicine

PSVT is disqualifying for aviation. After six months grounding, designated personnel may be considered for waiver of a single episode of PSVT, unassociated with structural heart disease, hypertension, thyrotoxicosis, WPW, etc, provided there are no recurrences. Recurrent PSVT is generally not waiverable.

Atrial Fibrillation. This is caused by chaotic atrial activity and manifested by fibrillatory waves occurring at a rate between 300 and 600, and an irregularly irregular ventricular response, generally between 120 and 180 (Figure 5-16). Slow ventricular responses may be caused by drugs that slow conduction through the AV node, such as digoxin, and in individuals with AV nodal disease. Occasionally, a healthy, athletic individual with high resting vagal tone will also have a slow ventricular response.

Atrial fibrillation is associated with rheumatic heart disease, especially mitral stenosis, atrial septal defects, cardiomyopathies, coronary artery disease, hypertension, pericarditis, and thyrotoxicosis. It may also occur in individuals with no underlying abnormality. These “lone fibrillators” have frequently overindulged in the use of caffeine, nicotine, and, most especially, alcohol (so called “holiday heart” syndrome). Atrial fibrillation may cause a significant decrease in cardiac output, as well as myocardial and cerebral blood flow. These adverse hemodynamic effects are of particular concern in the aviation environment where G forces and hypoxia may additionally reduce tissue perfusion and oxygen delivery. Furthermore, persistent and recurrent atrial fibrillation is associated with a significant increase in the risk of embolic strokes, even for “lone fibrillators.”

Atrial fibrillation is disqualifying for all flying duties. Designated aviation personnel with a single episode of atrial fibrillation unassociated with underlying heart disease or other predisposing condition may be waived after six months grounding. Recurrent atrial fibrillation is permanently disqualifying.

Atrial Flutter. This arrhythmia, which is probably caused by a reentry mechanism, is characterized by a rapid atrial rate (280-320) and a variable degree of AV block, most commonly 2:1 (Figure 5-17). One to one conduction is poorly tolerated, and, fortunately, uncommon. Higher degrees of AV block, as high as 8:1 are seen, with 4:1 the next most common. High degrees of AV block may be associated with drugs such as digoxin, beta blocking agents, or verapamil, or by underlying AV nodal disease. Atrial flutter is an unstable rhythm that frequently deteriorates into atrial fibrillation, occasionally reverts to sinus rhythm.

Atrial flutter may be caused by many of the same disorders that are associated with atrial fibrillation, but is much less likely to be seen in an otherwise normal individual, and is therefore disqualifying for all duty involving flying.

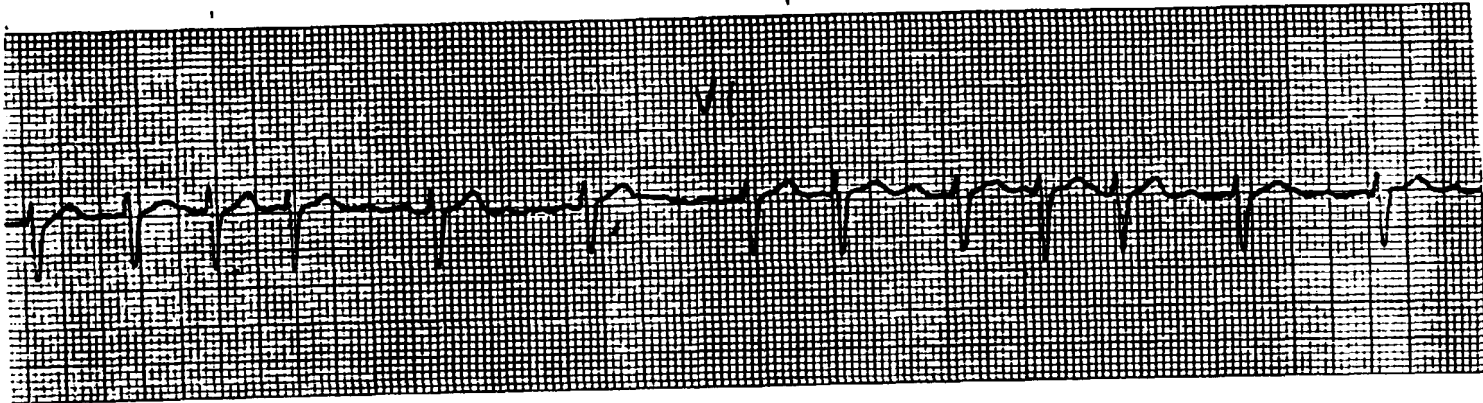

1 651-40

Figure 5-16. Atrial fibrillation.

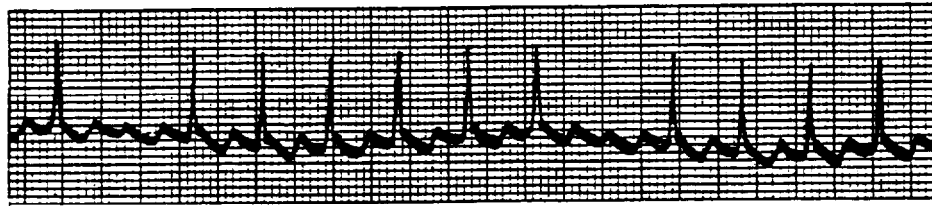

Figure 5-17. Atrial flutter.

Ventricular Tachycardia. Ventricular tachycardia and ventricular fibrillation are life threatening arrhythmias that are uncommon in the active duty population. The flight surgeon should be ACLS certified and therefore prepared to diagnose and treat V-tach and V-fib. They are, of course, disqualifying for all aviation personnel. This includes nonsustained ventricular tachycardia, which may occasionally be seen in what appear to be otherwise healthy individuals.

Brief episodes of ventricular tachycardia may occur during graded exercise testing of individuals without underlying heart disease. Such individuals are not at increased risk for cardiovascular complications and may be waived to return to flying, provided a complete cardiovascular workup is normal. This may require coronary arteriography in individuals over 35 years of age or with significant risk factors of coronary artery disease.

Acquired and Congenital Structural Heart Disease

Structural disease of the valves and walls of the cardiovascular system can present to the flight surgeon in a variety of ways. A new murmur, a subtle ECG finding, or a suspicious X-ray may be the first clue. Conversely, a well-documented lesion that may or may not have had surgery might be the presenting factor. Structural defects and aviation are not necessarily incompatible. Knowledge of the current cardiovascular status and the natural history of the lesion, particularly with regard to the risk of sudden incapacitating arrhythmias, is essential to intelligent management. A good history, physical examination, ECG, chest X-ray, echocardiogram (including color flow/doppler study), 24-hour Holter monitor, and graded exercise test can give an excellent assessment of current function. Some disorders may require cardiac catheterization. The patient's future in aviation will depend on the demonstration of normal cardiovascular function, a low risk of eventual slow decompensation, and virtually no increase arrhythmia risk over the general population. Several of the more likely defects to occur in the otherwise healthy, young adult deserve further comment.

Functional (Innocent) Murmurs

These murmurs, by definition, do not represent cardiac defects, but differentiating them from true disease can be difficult. The classical functional murmur is a low-frequency, musical, or buzzing murmur, less than II/VI in intensity, appearing in early to mid-systole and localized to the left sternal border. There must be no diastolic component, and the second sound must be normally split. Such a murmur presumably represents blood flow across a normal pulmonic or aortic valve and is more common in slender, athletic individuals.

An innocent systolic murmur with characteristics similar to the above has been described at the cardiac apex. Special care must be taken to differentiate it from mitral murmurs, particularly the mitral valve prolapse syndrome.

Congenital Shunts

Septal defects occurring at both the atrial and ventricular level and patent ductus arteriosus are the most common shunts that may be present in a seemingly fit young adult. Any of the three may present *de novo*, if small, or may present many years after surgical repair.

Atrial Septal Defect. Small atrial septal defects (ASD) may exist through a normal lifespan and be detected only at autopsy. The flight surgeon, however, may detect them in the course of a workup for a systolic murmur, right bundle branch block, or a fullness of the right ventricle or pulmonary artery on X-ray. The characteristic, widely split second sound, pulmonic flow murmur, and right ventricular enlargement solidify the diagnosis. Cardiac catheterization is always indicated, and all but the smallest defects should be closed. Normal right ventricular and pulmonary artery pressures carry an excellent prognosis postsurgery, but there is a small increase in the risk of supraventricular tachycardias. Candidates for aviation training with an ASD, repaired or not, are not accepted. If ASD is detected in a designated aviator, he or she may be considered for waiver if the shunt is trivial or the defect is repaired, provided that the patient has normal pulmonary artery and right sided pressures and no evidence of supraventricular tachycardias during a six month period of grounding.

Ventricular Septal Defect. Ventricular septal defects (VSD) are usually diagnosed in infancy. Moderately large shunts that are repaired in childhood with normal intracardiac pressures postsurgery have an excellent prognosis, but an increased risk of arrhythmias is disqualifying for an aviation career. A slight VSD in the asymptomatic child progressively becomes smaller as the child grows and thus may present in the young adult as only a positive history with or without a systolic murmur. The natural history of this lesion is virtually normal and thus is compatible with

military aviation. Nevertheless, a complete, normal cardiovascular examination, including 24-hour ECG monitoring and echocardiogram, is needed. Subacute bacterial endocarditis (SBE) prophylaxis is also indicated in these patients.

Patent Ductus Arteriosus. A patent ductus arteriosus surgically corrected in childhood with normal cardiovascular function one year postsurgery has an excellent prognosis and presents no contraindication to an aviation career. The small ductus that remains undetected and asymptomatic until young adulthood is rare. In these patients, pulmonary plethora, left ventricular enlargement, or a continuous high frequency murmur under the left clavicle may suggest the diagnosis. The chest X-ray may show the ductus as a convexity between the aorta and the pulmonary artery. Cardiac catheterization is always indicated. If the shunt is small (less than 1.5:1) and all pressures are normal, the prognosis is generally excellent, although SBE prophylaxis is indicated. These people may qualify for aviation. Large shunts require surgery, and the decision to pursue a career in aviation should be deferred until at least one year postsurgery.

Congenital Valvular Malformations

Mild stenosis of the pulmonic valve is consistent with near normal growth, virtually symptom free, carrying only the diagnosis of "functional murmur." However, mild exercise intolerance, evidence of right ventricular enlargement on physical examination, large anterior R-waves on ECG, and poststenotic dilation on chest X-ray should make one suspicious of the diagnosis. Cardiac catheterization is necessary for full evaluation. Since normal right ventricular pressures are mandatory for military aviation, individuals with this uncorrected malformation are generally disqualified. Surgery with near normal postoperative pressures is associated with excellent results, but, again, the small arrhythmia risk usually disqualifies the individual from an aviation career.

Congenital aortic stenosis, though often with a more benign prognosis than its rheumatic counterpart, still has a risk of eventual myocardial decompensation and arrhythmias and is therefore unacceptable for aviation.

The bicuspid aortic valve is a very common congenital abnormality occurring in 0.4 percent of individuals, with a male to female predominance of 4:1. Though the initial clinical course is benign and asymptomatic, leaflet thickening invariably occurs by age 40 with later progression of calcifications and stenosis. For this reason, individuals with bicuspid aortic valves should be evaluated for any evidence of an increased gradient across the aortic valve, or left ventricular hypertrophy by echocardiography and doppler study. Applicants for flight training are disqualified even with otherwise normal echo and doppler studies. Designated aviators with bicuspid aortic valves should have their cardiovascular function assessed by noninvasive means and

followed for the possible development of hemodynamically significant aortic stenosis or aortic regurgitation.

Coarctation of the Aorta

A coarctation is usually diagnosed in the pediatric population, but occasionally a mild one will not be detected until young adulthood. Upper body hypertension, a systolic murmur that radiates to the back, rib notching on chest X-ray, and evidence of left ventricular enlargement are the presenting signs in the adult. Additionally, bicuspid aortic valves and berry aneurysms are associated with coarcts. The disease is progressive and surgery is almost always indicated. In spite of possible excellent hemodynamics postsurgery, patients with coarcts have an increased risk of intracranial hemorrhage, eventual hypertension, and accelerated coronary artery disease. Thus, their place in military aviation is limited, and most, if not all, should be disqualified.

Rheumatic Valvular Disease

Valvular dysfunction on a rheumatic basis, even if mild, is associated with an increased risk of arrhythmias, cardiac failure, and emboli, and thus is disqualifying. Valve replacement, though often of great benefit hemodynamically, is inconsistent with a career in military aviation. A history of acute rheumatic fever (ARF) without evidence of valvular dysfunction is not disqualifying. Antibiotic prophylaxis against recurrent ARF is also not disqualifying.

Mitral Prolapse Syndrome (MVP)

Mitral valve prolapse (MVP) is the most common valvular abnormality, affecting from between two and 10 percent of the population. Primary mitral valve prolapse affects women more commonly than men and may be inherited as an autosomal dominant trait. Mitral valve prolapse may be associated with a number of other disorders including Marfan syndrome, cardiomyopathies, coronary artery disease, Ehlers-Danlos syndrome, WPW, and congenital defects such as ASD. Most individuals with idiopathic mitral valve prolapse are asymptomatic, but some experience atypical chest pain, fatigue, dizziness, and syncope. About 50 percent of patients have arrhythmias, including PSVT, PVC's, AV blocks, and V-tach. Some studies indicate an increased risk of sudden death.

A definitive diagnosis may be made by auscultation. Single or multiple mid-to late systolic clicks associated with a late systolic crescendo murmur are characteristic. The click(s) and murmur typically move earlier in systole during maneuvers that decrease the LV size such as moving from supine to sitting or squatting to standing.

Internal Medicine

A definitive diagnosis may also be made by two dimensional echo. Definite systolic prolapse of one or both mitral leaflets and the point of coaptation above the mitral annulus on multiple views should be demonstrated. An echocardiographic diagnosis of MVP should not be based on the apical four chamber view alone.

Individuals with MVP may experience PSVT, infective endocarditis, embolic cerebral vascular accidents, progressive mitral regurgitation, and possibly sudden death. MVP is therefore disqualifying for aviation, and applicants found to have MVP are rejected. Designated personnel may be waived to all service groups provided they are asymptomatic, they have no underlying condition that is itself disqualifying, they have no evidence of arrhythmias by history or on 24-hour Holter monitoring, and there is no significant mitral regurgitation or left atrial enlargement on echo/doppler.

Obstructive Hypertrophic Cardiomyopathy

Obstructive Hypertrophic Cardiomyopathy is an inherited disorder transmitted as an autosomal dominant trait with a high degree of penetrance although sporadic cases are not unusual. The hypertrophied left ventricle impedes ventricular filling during diastole resulting in increased left ventricular end diastolic pressures which are transmitted to the left atrium and pulmonary circulation causing dyspnea, the most frequent symptom. Other symptoms include angina, palpitations, syncope, and sudden death which may be the first manifestation of the disease. It is the most frequent cause of sudden death in young athletes. On physical examination a systolic ejection murmur is heard that increases with maneuvers that decrease the size of the left ventricle such as standing, valsalva, amyl nitrate, and is decreased by squatting and during hand grip.

The diagnosis is confirmed by two dimensional echocardiography, where LVH with a septum posterior wall ratio of 1.3:1 is found. Obstructive Hypertrophic Cardiomyopathy is disqualifying for the duties involving flying, with no waivers granted.

Endocarditis Prophylaxis

Individuals with prosthetic heart valves, valvular heart disease, and certain congenital heart defects are at increased risk for endocarditis following certain medical procedures on the oral cavity, respiratory, genitourinary, and gastrointestinal tracts. Table 5-4 lists the conditions for which prophylactic antibiotic therapy is indicated. Table 5-5 lists the procedures requiring prophylaxis and Tables 5-6 and 5-7 summarize the prophylactic regimens recommended by the Committee on Rheumatic Fever and Infective Endocarditis of the American Heart Association.

Although most of the conditions in Table 5-4 are disqualifying for aviation, aircrew members with bicuspid aortic valves and mitral valve prolapse may be waived and may require SBE prophylaxis. Mitral prolapse with single or multiple clicks but without a murmur does not require SBE prophylaxis.

Table 5-4

Cardiac Conditions for Which Endocarditis Prophylaxis is Recommended

Endocarditis prophylaxis recommended

- Prosthetic cardiac valves (including biosynthetic valves)
- Most congenital cardiac malformations
- Surgically constructed systemic-pulmonary shunts
- Rheumatic and other acquired valvular dysfunction
- Idiopathic hypertrophic subaortic stenosis
- Previous history of bacterial endocarditis
- Mitral valve prolapse with insufficiency

Endocarditis prophylaxis not recommended

- Isolated secundum atrial septal defect
 - Secundum atrial septal defect repaired without a patch 6 or more months earlier
 - Patent ductus arteriosus ligated and divided 6 or more months earlier
 - Postoperatively after coronary artery bypass graft surgery
-

Atherosclerotic Heart Disease

Myocardial ischemia occurs when oxygen delivery is insufficient to meet myocardial oxygen demand. High $+G_z$ forces can greatly increase myocardial oxygen demand, with heart rates over 200 beats per minute and left ventricular pressures of almost 300 mm Hg. At the same time, $+G_z$ forces tend to reduce coronary artery blood flow due to reduced aortic pressures, decreased duration of diastole, and increased myocardial compressive forces. Through neural influences and autoregulation, the normal coronary circulation is able to increase coronary blood flow from four to six times the resting state in response to maximal stress, and clinically apparent myocardial ischemia does not occur before the onset of $+G_z$ induced loss of consciousness. Coronary

Internal Medicine

arteries with obstructions, however, have a limited ability to increase blood flow. Obstruction of 80 to 90 percent of the arterial lumen allows for no increase in flow while obstructions of 40 percent and less do not limit flow even at maximum demand, unless there is superimposed coronary artery spasm.

Myocardial ischemia presents clinically as angina, myocardial infarction, depressed LV function, and sudden death, all of which can cause sudden and unexpected in-flight incapacitation. For this reason, known coronary artery disease of any severity, even if asymptomatic, is disqualifying for aviation.

Table 5-5

Procedures for Which Endocarditis Prophylaxis is Indicated

Oral cavity and respiratory tract

All dental procedures likely to induce gingival bleeding (not simple adjustment of orthodontic appliances or shedding of deciduous teeth)

Tonsillectomy or adenoidectomy

Surgical procedures or biopsy involving respiratory mucosa

Bronchoscopy, especially with a rigid bronchoscope

Incision and drainage of infected tissue

Genitourinary and gastrointestinal tracts

Cystoscopy

Prostatic surgery

Urethral catheterization (especially in the presence of infection)

Urinary tract surgery

Vaginal hysterectomy

Gallbladder surgery

Colonic surgery

Esophageal dilatation

Sclerotherapy for esophageal varices

Colonoscopy

Upper gastrointestinal tract endoscopy with biopsy

Proctosigmoidoscopic biopsy

Table 5-6

Summary of Recommended Antibiotic Regimens for Adults Having Dental or Respiratory Tract Procedures

Standard Regimen	
For dental procedures that cause gingival bleeding, and oral or respiratory tract surgery	Penicillin V, 2.0 g orally, 1 hour before, then 1.0 g 6 hours later. For patients unable to take oral medications, 2×10^6 U of aqueous penicillin G intravenously or intramuscularly 30 to 60 minutes before a procedure and 1×10^6 IU 6 hours later may be substituted.
Special Regimens	
Parenteral regimen for use when maximal protection is desired, for example, for patients with prosthetic valves	Ampicillin, 1.0 to 2.0 intramuscularly or intravenously, plus gentamicin, 1.5 mg/kg body weight intramuscularly or intravenously, 0.5 hours before procedure, followed by 1.0 g or oral penicillin V 6 hours later. Alternatively, the parenteral regimen may be repeated once 8 hours later.
Oral Regimen for patients allergic to penicillin	Erythromycin, 1.0 g orally 1 hour before, then 500 mg 6 hours later.
Parenteral regimen for patients allergic to penicillin	Vancomycin, 1.0 g intravenously, slowly over 1 hour, starting 1 hour before. No repeat dose is necessary.

Table 5-7

Summary of Recommended Regimens for Adults Having Gastrointestinal or
Genitourinary Tract Procedures

Standard Regimen	
For genitourinary and gastrointestinal tract procedures, listed in Table 2	Ampicillin, 2.0 intramuscularly or intravenously, plus gentamicin, 1.5 mg/kg body weight intramuscularly or intravenously, given 0.5 to 1 hour before the procedure. One follow-up dose may be given 8 hours later.
Special Regimens	
Oral regimen for minor or repetitive procedures in low-risk patients	Amoxicillin, 3.09 orally, 1 hour before procedure and 1.5 g 6 hours later.
Patients allergic to penicillin	Vancomycin, 1.0 g intravenously, given slowly over 1 hour, plus gentamicin, 1.5 mg/kg body weight intramuscularly or intravenously, given 1 hour before procedure. May be repeated once 8 to 12 hours later.

Screening Asymptomatic Individuals for Coronary Artery Disease

If a noninvasive test for detecting coronary artery disease were available it would be desirable to screen aviation personnel for coronary artery disease and exclude affected individuals. The most common available test is the exercise electrocardiogram which has a specificity of 84 percent and a sensitivity of 66 percent. Leaving aside the poor sensitivity, the application of such a test to a patient population with a low prevalence of a disease, such as coronary artery disease in asymptomatic individuals under the age of 45, results in many more false positive tests than true positive tests. This creates a serious disposition problem since coronary artery disease must be reasonably excluded in everyone with a positive test. The result would be a large number of expensive, time consuming, and frequently invasive workups in healthy individuals. For this reason, the routine use of graded exercise testing to detect coronary artery disease in asymptomatic individuals cannot be justified.

Evaluation of Individuals with Chest Pain

The workup of symptomatic patients must be individualized. At one extreme are young individuals without multiple coronary risk factors and atypical chest pain for whom graded exercise testing is the most that would be required, while patients with multiple risk factors and exertional chest pain would require coronary arteriography.

Treated Coronary Artery Disease

Many patients with coronary artery disease are now undergoing coronary artery bypass grafting (CABG) or percutaneous transluminal coronary angioplasty (PTCA) with excellent results. Many are asymptomatic with normal maximal exercise testing, but they are still considered disqualified for all duties involving flying. Graft (CABG) and coronary artery (PTCA) patency remain a significant and unpredictable problem, and coronary atherosclerosis tends to be a progressive disorder that will eventually affect other portions of the coronary anatomy.

Hypertension

Hypertension is one of the most important health problems facing the flight surgeon, because:

1. It is a very common condition.
2. It is usually asymptomatic until late on, when significant target organ damage has already occurred.

Internal Medicine

3. It is associated with serious complications, including coronary artery disease, congestive heart failure, stroke, and renal failure.
4. Effective treatment is readily available.

The first step is to correctly establish a diagnosis. It is easily overdiagnosed; 40 percent of patients with diastolic pressures over 90 are found to be normotensive on followup, and 21 percent of patients found to have persistently elevated diastolic pressures on three successive visits to the doctor's office are found to be normotensive by 24-hour ambulatory blood pressure monitoring ("white coat" hypertension). An inappropriate diagnosis of hypertension may have serious adverse effects on employment, life and health insurance, and may commit the individual to lifelong treatment unnecessarily.

What constitutes hypertension? This question is not as easily answered as might be expected, since the distribution of blood pressures is represented by a unimodal curve; there is no sharp distinction between "normal" pressures and "high" pressures associated with an increased risk of complications. The U.S. Navy standards for blood pressure are as follows: less than 140/90 - SNA, SNFO, DNA SG I and II (under age 36); less than 150/90 - DNA SG I and II (36 and older); less than 154/94 - DNA SG III, NFO, Flight Surgeon, etc.

Once the presence of hypertension has been established, a workup is necessary to exclude secondary causes and search for target organ damage. Inappropriate hypertension (Table 5-8) should trigger a careful search for secondary hypertension.

Some of the more important secondary causes of secondary hypertension include: renal and adrenal disorders and disorders of the aorta.

Renal Parenchymal Disease (up to 0.4 Percent)

Many acute and chronic renal disorders are associated with hypertension. A urinalysis with careful examination of the sediment, BUN, and creatinine will reasonably screen for most of these.

Renovascular Hypertension (0.2 Percent)

Obstruction of a renal artery tends to occur in younger patients (under 30, female > male) due to fibromuscular dysplasia, and older patients (over 50, male > female) due to atherosclerosis. Suggestive features include an abdominal bruit, especially if there is a diastolic component, appropriate age, and a rapidly accelerating course.

Table 5-8

Features of Inappropriate Hypertension

1. Onset before the age of 20 or after 50.
 2. Blood pressure greater than 180/110.
 3. Evidence of target organ damage:
 - a. Grade 2 or greater fundoscopic changes.
 - b. Decreased renal function.
 - c. Cardiomegaly or left ventricular hypertrophy.
 4. Signs or symptoms suggestive of secondary hypertension:
 - a. Unprovoked hypokalemia.
 - b. Abdominal bruit.
 - c. Wide variations in blood pressure associated with spells of sweating, tachycardia, and tremulousness.
 - d. Family history of renal disease.
 5. Difficult to control hypertension.
-

Adrenal Causes

Primary Aldosteronism (0.1 to 1 Percent). Primary aldosteronism is caused by an adrenal adenoma or primary adrenal hyperplasia. This is marked by unprovoked (i.e., diuretic Rx) hypokalemia.

Cushing's Syndrome (0.1 Percent). Cushing's Syndrome is suggested by typical physical findings of central obesity, moon facies, and purple striae.

Pheochromocytoma (0.2 Percent). Pheochromocytoma is manifested by marked swings in blood pressure, a significant orthostatic drop in blood pressure, and spells of sweating, tachycardia, and tremulousness.

Coarctation of the Aorta (0.1 to 0.2 Percent)

This is usually asymptomatic. Physical findings include a wide pulse pressure in the upper extremities, a lower than expected blood pressure in the lower extremities, a delay in the femoral pulse compared to the brachial pulse, and a systolic murmur between the scapulae. The chest X-ray may show post stenotic dilatation of the aorta and notching of the inferior edge of the ribs.

Diagnosis and Treatment of Hypertension

A good history, physical examination, and some easily obtained laboratory studies can effectively screen for secondary hypertension. Since secondary hypertension may be curable, or represent a serious underlying condition, this workup is necessary. Documented or suspected cases of secondary hypertension should be referred for further workup and treatment.

The hypertension workup is completed by a search for target organ damage in the eyes (fundoscopic exam), heart (auscultation, chest X-ray, 12 lead ECG, and, possibly, echocardiogram), and kidneys (active sediment or protein in the urine, elevated BUN or creatinine.)

Ninety-five percent of hypertensive individuals have no underlying cause and are labeled "essential" hypertensives. Nonpharmacological therapy including weight reduction (if appropriate), sodium restriction, and regular aerobic exercise, is appropriate initial treatment for mild or moderate essential hypertension. Aviation personnel with essential hypertension controlled with nonpharmacological treatment are not considered disqualified and therefore do not require a waiver.

Drug therapy is required for hypertension not controlled by nonpharmacological means. Hydrochlorothiazide is a reasonable first step drug that does not require a waiver. It is effective in the majority of individuals with mild hypertension and is usually well tolerated. Adverse biochemical effects, usually mild, include hyperuricemia, hypercalcemia, hypercholesterolemia, and hypokalemia.

U.S. Naval Flight Surgeon's Manual

All other antihypertensive agents are disqualifying for aviation. Waivers are readily granted for the angiotensin converting enzyme inhibitor enalapril, which decreases peripheral vascular resistance but has little effect on cardiac output, heart rate, glomerular filtration, or salt and water balance. This drug is usually very well tolerated and most importantly, has none of the adverse CNS effects common with other antihypertensive agents.

Beta blocking agents have the potential for adverse hemodynamic and CNS side effects, and therefore are rarely waived, and then only in SG III and Class 2 personnel. If a beta blocking agent is necessary, a lipid insoluble drug, such as atenolol, is preferable since CNS penetration is minimal and undesirable CNS effects avoided.

SECTION II. GASTROENTEROLOGY

Esophageal Reflux and Hiatal Hernia

Symptomatic gastroesophageal reflux is an extremely common disorder, involving up to 33 percent of the population infrequently and about 10 percent with frequent or severe symptoms.

About two thirds of symptomatic patients have transient decreases in lower esophageal sphincter (LES) pressure allowing the reflux of gastric contents into the esophagus resulting in damage to the esophageal mucosa from acid and pepsin (less commonly, bile and pancreatic enzymes). The remaining third have persistently low or absent LES pressures and free reflux, resulting in more severe esophagitis and a higher likelihood of complications. Gastric volume is also important and may be increased, for example, by delayed gastric emptying. Another related factor is the esophageal clearance of acid which is increased by swallowing, due to esophageal peristalsis and ejection of acid into the stomach, and by neutralization of acid by swallowed saliva. Since swallowing and salivation virtually cease during sleep, clearance of refluxed gastric contents is reduced at night.

There is no clear relationship between hiatal hernia and reflux esophagitis. While many symptomatic patients have hiatal hernias, most individuals with a hiatal hernia do not have reflux esophagitis. It is possible that the presence of a hiatal hernia may decrease the clearance of acid in symptomatic patients.

Mild to moderate esophagitis is manifested by epigastric and substernal burning. Other symptoms may reflect complications and include regurgitation; aspiration, as evidenced by pneumonia, morning hoarseness, and nocturnal choking; dysphagia caused by a peptic stricture; severe chest pain which may be caused by severe esophagitis, esophageal spasm, or an esophageal ulcer; and occasionally odynophagia.

Complications associated with gastroesophageal reflux include hemorrhage and perforation, both of which are unusual; pulmonary complications such as aspiration pneumonia; peptic strictures that are usually of mild to moderate degree; and Barrett's esophagus. Barrett's esophagus is the replacement of the normal squamous esophageal epithelium by columnar epithelium, which may be metaplastic. A high percentage of patient's with Barrett's esophagus have strictures (up to 60 percent), and there is an increased risk of esophageal adenocarcinoma (up to 10 percent).

Although patients with mild or moderate esophagitis frequently have normal upper GI studies, except possibly for the demonstration of gastroesophageal reflux, barium studies are useful to ex-

clude other disorders, such as peptic ulcer disease, and to detect peptic strictures, Barrett's esophagus, and ulceration. Perfusion of the distal esophagus with acid (Bernstein test) usually reproduces the patient's symptoms with esophagitis and is useful to exclude coronary artery disease. Additional studies, such as endoscopy +/-biopsy, 24-hour pH monitoring, and esophageal manometry may be useful when the diagnosis is still in doubt, the patient is unresponsive to intensive medical management, or an abnormal barium swallow (stricture, Barrett's esophagus) requires it.

Initial management of reflux esophagitis includes elevation of the head of the patient's bed with six inch blocks; dietary modifications including restriction of caffeine, specific irritants such as citrus juice, tomatoes, etc, multiple small meals, and no eating within several hours of going to bed; no smoking; and, the use of alginic acid and an antacid (Gaviscon) 30 minutes pc and hs. For patients uncontrolled by these measures, one of H₂ antagonists (cimetidine, ranitidine, or famotidine) would be the next appropriate step, followed by bethanochol or metachlopramide. Antireflux surgery, such as the Nissen fundoplication, is reserved for patients unresponsive to medical management.

Aeromedical Disposition

Aircrew members with mild or moderate symptoms, no complications, and who are controlled by nonpharmacological measures and Gaviscon, are physically qualified for all flight duties. Patients with severe esophagitis and with complications are NPQ. Aircrew in tactical jet aircraft may be at an increased risk of aspiration if they experience the reflux of a large volume and regurgitate while performing anti-G maneuvers. Waivers may be granted for nightly use of ranitidine or following successful anti-reflux surgery.

Peptic Ulcer Disease

Duodenal Ulcers

Approximately 10 percent of males and 4 percent of females will develop a symptomatic duodenal ulcer (DU) at some times during their life, with the peak incidence in the fifth and sixth decades. Dietary factors, including alcohol and caffeine, do not appear to be related to DU's. Cigarette smoking is probably a risk factor for the development of peptic ulcer disease and is clearly associated with a much higher rate of recurrence. Nonsteroidal anti-inflammatory agents are not a proven risk factor but have been shown to cause inflammation and erosions of the duodenal and gastric mucosa. There is no proven association between ulcers and corticosteroid therapy.

Internal Medicine

Classic symptoms for duodenal ulcers include postprandial and nocturnal epigastric pain and burning relieved with food and antacids. However, some patients have atypical symptoms or are asymptomatic, and duodenal ulcers cannot be distinguished from gastric ulcers or other disorders such as reflux esophagitis and nonulcer dyspepsia by history alone. Upper GI barium studies can miss up to 50 percent of duodenal ulcers, although the detection rate may be as high as 80 to 90 percent with double contrast studies performed by an experienced radiologist. Endoscopy detects over 95 percent of duodenal ulcers, and is able to detect other disorders not seen by barium studies such as gastritis, esophagitis, and small ulcers. It is more expensive, however, and associated with a small risk of complications such as perforation.

Duodenal ulcerations tend to heal without treatment, although patients become more rapidly asymptomatic and have higher healing rates if treated. Standard treatments include the H₂ blocking agents cimetidine, ranitidine and famotidine; antacids; and sucralfate, a cytoprotective agent that does not inhibit acid formation. The rate of healing is about the same with any of these medicines, and there is no clear evidence that combination therapy is superior. In fact, sucralfate requires an acidic pH to be active and may not be effective when combined with antacids or H₂ receptor agents. The H₂ receptors have been shown to be equally effective when given as a single nightly dose (cimetidine 800 mg hs or ranitidine 150 mg hs) compared to divided daily doses for uncomplicated duodenal ulcers.

Peptic ulcer disease is disqualifying for aviation. The overall recurrence rate is from 50 to 80 percent within the first 12 months, and there is a significant risk of serious complications having the potential for sudden inflight incapacitation. Designated personnel should undergo endoscopy, if available, or an upper GI series for diagnosis, and then be placed on one of the standard therapies. It is essential for these patients to avoid smoking, nonsteroidal anti-inflammatory agents, and, during the acute phase, alcohol. They are grounded for a six week period during treatment. If they are asymptomatic while off all medications and have experienced no complications (bleeding, perforation, or obstruction) they may be waived to resume flight duties. Repeat endoscopy or Upper GI series is required to document ulcer healing. Patients with intractable symptoms, frequent recurrences (two or more a year), or complications must be carefully evaluated. Individuals taking nightly maintenance doses of ranitidine may be waived in selected cases. Some individuals may be returned to flight duties after successful ulcer surgery.

Gastric Ulcers

In general, gastric ulcers are diagnosed and managed in the same manner as duodenal ulcers. They tend to occur in older patients and, unlike duodenal ulcers, have a significant risk of malignancy (about 20 percent). Double contrast upper GI studies detect most (90 percent) gastric

ulcers and can most often distinguish between benign and malignant lesions. However, all patients with gastric ulcers should undergo endoscopy to exclude the presence of malignancy. The aviation disposition for an uncomplicated benign gastric ulcer is the same as for a duodenal ulcer.

Inflammatory Bowel Disease

Crohn's disease and ulcerative colitis are inflammatory disorders of the colon and, in the case of Crohn's disease, other parts of the GI tract. They are characterized by diarrhea, abdominal pain, rectal bleeding, and by involvement of other organ systems including joints, liver, eyes, and skin. They are differentiated by histology, and by typical involvement, with ulcerative colitis involving the rectosigmoid and extending for variable degrees proximally without skipped areas, and Crohn's disease most frequently involving the distal ileum, variable and patchy involvement of the colon with skipped areas, but with the potential for involving any portion of the GI tract. Crohn's frequently causes penetration of the intestinal wall and fistulous tract formation.

The fluctuating and unpredictable clinical course of both these disorders makes them disqualifying for all flight duties. Some patients with ulcerative proctitis (involvement less than 20 cm) have mild symptoms that are easily treated with hydrocortisone or 5-ASA enemas, and progress to involve more of the colon only about 15 percent of the time. These individuals may be waived provided they are asymptomatic on medicated enemas and/or 2 grams of sulfasalazine per day.

Alcoholic Liver Disease

Alcoholism remains a serious problem for the Navy. Beyond the very serious consequences of driving (and in rare instances flying) while intoxicated, most of the 200,000 alcoholics who die annually in the U.S. die from complications of alcoholic liver disease. About 15 to 20 percent of individuals who drink more than 40 to 80 gms of ethanol a day for over 10 years will develop cirrhosis. Some, mostly women, will develop cirrhosis from drinking much less.

Fatty Liver

The mildest form of liver involvement is a fatty liver. Patients with fatty liver are usually asymptomatic, although they may have tender hepatomegaly. Liver enzymes and bilirubin are normal or only mildly elevated. These patients have an excellent prognosis if they abstain from alcohol. The fatty changes are rapidly reversible once drinking is discontinued. Aviation personnel should be grounded and treated aggressively for alcohol dependence. The decision to return them to flying duties is usually dependent on the success of their achieving and maintaining

Internal Medicine

sobriety. From an internal medicine standpoint, they are qualified to resume flying if they have normal hepatic function, as evidenced by normal liver enzymes, bilirubin, albumin, prothrombin time, and CBC; and, there is no history or evidence of portal hypertension.

Alcoholic Hepatitis

Alcoholic hepatitis is a much more serious disorder characterized by anorexia, nausea, vomiting, weight loss, abdominal pain, fever, and jaundice. Portal hypertension may cause ascites, splenomegaly, and bleeding esophageal varices. Liver enzymes are elevated five to 10 times normal, with SGOT being significantly more elevated than SGPT. Jaundice is present at times accompanied by hypoalbuminemia, prolonged prothrombin times, and anemia. Some patients may progress to hepatic failure or hepatorenal syndrome. Although some patients recover fully, most either continue to have hepatitis or develop cirrhosis. Individuals with alcoholic hepatitis will rarely be considered for a return to flying.

Cirrhosis

Cirrhosis represents the end stage of alcoholic liver disease where the liver has dense bands of connective tissue and areas of micronodular regeneration. Symptoms are caused by hepatic dysfunction and portal hypertension. Cirrhosis is permanently disqualifying for aviation duties.

SECTION III: HEMATOLOGY

Anemias - An Overview

Due to the vast scope of this subject, the reader is referred to standard medical texts and hematology references for detailed studies of specific hematological topics. A basic classification of anemias will be outlined herein as a general diagnostic aid.

Morphological classification of anemias is a simple method which directs further investigational study. Three measurements of red cell morphology are utilized in determining cell size and hemoglobin concentration:

1. Mean Corpuscular Volume (MCV).
2. Mean Corpuscular Hemoglobin (MCH).
3. Mean Corpuscular Hemoglobin Concentration (MCHC).

The listed values can be determined on the basis of results provided by a complete blood count, though are usually already calculated on automated cell counters widely used.

Table 5-9 provides an outline for the morphological classification of anemias to aid the investigator in his pursuit of the cause of a patient's anemia. By obtaining a complete blood count (CBC) on a patient in whom anemia is suspected, the physician can categorize the anemia into its appropriate morphological type. Thus, insight is provided into subsequent diagnostic studies necessary to determine the precise disorder involved. The importance of determining the etiology of the anemia cannot be overstated; "anemia" in and of itself is not a specific diagnosis. Administration of blood, iron, or vitamins on the basis of "anemia" without a specific diagnosis is completely inappropriate.

In general, uncorrected anemia is cause for grounding of an aviator. If the etiology of the anemia is found and corrective measures are taken, the aviator can be returned to an "up" status as long as the patient's hemoglobin and hematocrit remain at acceptable levels and the underlying cause of the anemia is not itself disqualifying.

The following limits are acceptable for aviation personnel:

Table 5-9

Morphologic Classification of Anemias

Anemia Classification	Criteria	Disease Type
Macrocytic With "Megaloblastic" Marrow	MCV > 94 cμ MCHC > 35% Macrocytosis, Anisocytosis, Poikilocytosis (Teardrop) on Smear	Pernicious Anemia Type
Without "Megaloblastic" Marrow	MCV > 94 cμ MCHC > 30% Macrocytosis, Target Cells on Smear	Liver Disease
Microcytic	MCV < 94 cμ MCHC > 30%, if subclassified as simple MCHC < 30%, if subclassified as "Hypochromic" Microcytosis, Hypochromia, Anisocytosis, Poikilocytosis on Smear	Nutritional Anemias Repeated Pregnancy Prematurity Inadequate Iron Intake in Infants (Milk Anemias) Chronic Blood Loss Thalassemia B ₆ Deficiency
Normocytic	MCV 80 to 94 cμ MCHC > 30% Normocytosis, Normochromia, Slight Anisocytosis and Poikilocytosis on Smear	Recent Bleeding Hemolysis Marrow Replacement Marrow Depression

HCT

HGB

Males	40 to 52 percent	14 to 18 gms/dl
Females	37 to 47 percent	12 to 16 gms/dl

If the average of three hematocrits falls outside of the acceptable range, but falls within the following ranges:

Males	38 to 39.9 percent	52.1 to 54 percent
Females	35 to 36.9 percent	47.1 to 49 percent

a hematology consultation is required. If no underlying disorder is discovered, the condition is not disqualifying. Values outside these ranges must be carefully evaluated and waivers considered on a case by case basis.

Hemoglobinopathies

Again, this topic is quite lengthy; discussion herein will be primarily limited to sickle cell diseases and thalassemia. Sickle cell hemoglobin (HGB S) represents a qualitative hemoglobin abnormality, while thalassemia represents a quantitative disorder of hemoglobin.

Sickle Cell Disease

HGB S aggregates when deoxygenated, thus distorting red cells and impairing microcirculation. Clumps of sickled cells occluding circulation result in local pain, necrosis, and fibrosis; often, symptoms of "crisis" are bizarre and involve many areas of the body simultaneously. In addition to hemolytic anemia and vascular occlusion, patients with sickle cell anemia may have severe infections.

Sickle cell trait, the heterozygous condition (HGB A-S), is rarely associated with clinical disease though the aeromedical literature contains conflicting reports of splenic infarctions and crisis after exposure to hypoxia. Previously, all individuals with sickle cell diseases were disqualified for duty involving flying. However, BUMEDINST 6260.26 of 27 November 1981, allowed individuals with 41 percent or less HGB S to enter aviation and diving training and established the Sickle Cell Trait Study Protocol to determine the true risk to these individuals in aviation and diving duties.

As before, sickle cell anemia (HGB S-S) and the mixed heterozygous conditions (HGB S-C, HGB S-D, HGB S-thalassemia, etc.) are disqualifying for aviation.

Thalassemia

Thalassemia, as used here, refers to A₂ thalassemia (a variety of beta-thalassemia) in which the A₂ hemoglobin fraction is elevated. Fetal hemoglobin (HGB F) levels are slightly elevated, and microcytosis with target cells can be seen on the peripheral smear. Examination may demonstrate moderate splenomegaly. There are three clinical subdivisions of thalassemia: (1) thalassemia minor; (2) thalassemia intermedia; and (3) thalassemia major. Thalassemia minor is usually discovered by accident during a routine physical examination of an asymptomatic patient. This "silent" form (sometimes described as thalassemia minor, variant minima) is compatible

Internal Medicine

with a normal life-span during which there are no clinical manifestations of the disorder. This diagnosis, if confirmed by the hemoglobin electrophoretic pattern in an asymptomatic patient, is not disqualifying for aviation, provided hematocrit levels are in the acceptable range.

In thalassemia intermedia, there is mild to marked splenomegaly, jaundice, recurrent abdominal pain (as a result of cholelithiasis or splenic enlargement), and skeletal changes similar to those in thalassemia major. Both thalassemia intermedia and thalassemia major are disqualifying.

SECTION IV: METABOLIC DISORDERS

Adrenal Disorders

A brief summary of adrenal disorders is as follows:

1. Glucocorticoid Excess
 - a. Cushing's Disease (Pituitary ACTH excess).
 - b. Cushing's Syndrome (either adrenal neoplasia or ectopic ACTH production).
2. Glucocorticoid Insufficiency
 - a. Primary Adrenocortical Failure (Addison's).
 - b. Secondary Adrenocortical Failure.
 - c. Adrenogenital Syndrome (rare and extremely unlikely to be disclosed in aviation personnel).

The flight surgeon is referred to standard medical texts for complete discussions of these dysfunctions. Either state is a grounding defect and warrants follow-up within the hospital system. Return to aviation following treatment is most unlikely.

Thyroid Disorders

Hyperthyroidism

Simply defined, hyperthyroidism is excessive production of thyroid hormones resulting in a hypermetabolic state with associated adrenergic-like symptoms.

Hyperthyroidism may be subdivided into relatively common and relatively rare forms. The most common forms include Grave's disease, toxic multinodular goiter, toxic adenoma, and factitious hyperthyroidism. Relatively rare forms include choriocarcinoma, metastatic testicular embryonal cell carcinoma, and struma. Treatment of hyperthyroidism includes medical agents and surgical approaches. Medical management may take the form of:

Internal Medicine

1. Iodine (for emergency treatment of thyroid storm or in preoperative patients) to reduce thyroid vascularity.
2. Propylthiouracil (PTU)/methimazole (Tapazole).
3. Propranolol.
4. Radioactive iodine (treatment of choice).

Surgical treatment is utilized in patients with solitary nodules. It is of importance to point out that hyperthyroidism is disqualifying in the aviator unless definitive treatment (either ^{131}I or surgical thyroidectomy) has been undertaken. In either of these instances, the potential for subsequent hypothyroidism is present.

Hypothyroidism

Hypothyroidism is a state of thyroid insufficiency in which a hypometabolic condition opposite that of hyperthyroidism ensues.

The most common form of hypothyroidism is that of primary hypothyroidism in which the thyroid gland itself cannot synthesize sufficient thyroid hormone for metabolic needs. The second most common form of hypothyroidism is observed following therapy. Radioactive ^{131}I therapy results in 25 percent of patients being hypothyroid at the end of one year and 50 percent of patients being hypothyroid at the end of 10 years. Other causes of hypothyroidism are uncommon, but virtually all require thyroid replacement (i.e., unless oversuppression by medical therapy for hyperthyroidism is the etiology).

If replacement therapy results in a euthyroid state, the aviator may be considered for a return to flight status, as long as follow-up thyroid studies and replacement therapy can be made available.

Disorders of the Glucose Metabolism

Diabetes Mellitus

Diabetes mellitus is a functional disturbance of pancreatic islet cells resulting in metabolic abnormalities in the handling of not only sugars, but proteins and fats as well. It constitutes the fifth leading cause of death in the United States behind coronary artery disease, cancer, accidents, and

renal disease. Over 50 percent of diabetics die because of coronary artery disease; diabetes is also the leading cause of adult blindness.

Diabetes has been recognized to result from two distinct clinical entities: insulin-independent (juvenile-onset), and noninsulin-dependent (adult-onset) diabetes. Insulin-dependent diabetes is noted to have HLA related genetic transmission, reduced serum insulin levels and may lead to ketoacidosis. Noninsulin-dependent diabetes has non-HLA associated genetic transmission, normal or high serum insulin levels, and rarely, if ever, results in ketoacidosis.

Laboratory diagnosis is a controversial issue, especially in terms of interpretation of the glucose tolerance test (GTT). Conditions under which a GTT should be done must be rigorous:

1. The patient must be on a carbohydrate-loading diet (300 gm/day) for a minimum of three days.
2. The patient must be rested, relaxed, and fully ambulatory.
3. The test must be in the morning.
4. The patient must be free from acute illness.
5. The patient should not be taking medication nor should he smoke during the test.

The physician must, himself, be acquainted with the laboratory techniques since plasma values are 15 to 20 percent higher than whole blood values.

Two commonly used criteria for interpretation of GTT's are outlined in Table 5-10.

Fajans-Conn criteria require that all three values (1, 1 1/2, and 2 hours) be exceeded for the diagnosis. For a positive diagnosis under the U.S.P.H.S. point system, two points are required.

Bear in mind that an abnormal GTT (i.e., one which does not meet the above diagnostic criteria) is not the equivalent of diabetes. The oral GTT is a poorly reproducible study and, for that reason alone, must be viewed with caution. To improperly label a patient as diabetic is as grave an injustice to him as is missing the diagnosis in a patient who is clearly diabetic on clinical and laboratory grounds. For these subclinical or latent diabetics ("glucose intolerance" being a better choice of terms in most instances), weight control and dietary programs are likely indicated.

Table 5-10

Interpretation of Values for the Standard GTT

	Fajans-Conn		U.S. Public Health Service		
	Whole Blood (mg %)	Plasma (mg %)	Whole Blood (mg %)	Plasma (mg %)	Points
Fasting			110	130	1
1 hour	160	185	170	195	½
1½ hours	140	150			
2 hours	120	140	120	140	½
3 hours			110	125	1

To make a point, there is no place in naval aviation for the overt diabetic, insulin-dependent or not. Oral hypoglycemics should not be considered as a means of keeping the pilot "up" since undesired side effects (e.g., hypoglycemia) may bring catastrophic results.

Hypoglycemia

Hypoglycemia indicates excessively rapid removal of glucose from the blood or an inability of gluconeogenesis to sustain adequate glucose levels. When blood sugar falls at a precipitous rate, the patient displays signs of hyperepinephrinemia (e.g., nervousness, palpitations, sweating, pallor, hunger, headache, and tremulousness). A slower fall in glucose (which may result in a lower blood sugar than the former state) may give rise to cerebral symptoms (e.g., blurred vision, somnolence, syncope, coma, and even seizures).

Hypoglycemia, which is not a specific disease state in and of itself, is classified as being either functional or organic. Organic hypoglycemia is related to a known anatomical lesion. Examples include beta-cell tumor of the pancreas, adrenocortical hypofunction, anterior pituitary hypofunction, epithelioid tumors derived from neural crest (e.g., insulin-producing carcinoid tumor). Functional hypoglycemia has no specific anatomical lesion. Examples include:

1. Exogenous hypoglycemia:
 - a. Iatrogenic - the diabetic who takes too much insulin.
 - b. Factitious - abuse by patients who have access to hypoglycemic drugs.

2. Reactive hypoglycemia:

- a. Alimentary hypoglycemia in postoperative gastrectomy or gastrojejunostomy patients.
- b. As a manifestation of glucose intolerance in the subclinical or latent diabetic.
- c. "Functional" hypoglycemia in the tense, anxious patient.

3. Hepatic dysfunction resulting in decreased gluconeogenesis. Most commonly, this is seen in the alcohol abuser who drinks excessively after periods of relative malnutrition or starvation.

In aviation personnel with a history suggestive of hypoglycemia, extensive evaluation may be required to document the abnormality and, whenever possible, the underlying cause. Caution should be observed in performing studies such as a 72-hour fast or tolbutamide tolerance test; these should be reserved for the hospitalized patient under careful observation. As stated previously, the interpretation of oral GTT's is an area fraught with pitfalls. The asymptomatic patient whose blood sugar at three hours falls to 50 mg per decaliter from a two-hour level of 90 mg per decaliter is more likely to be a variant of normal than is the patient who develops symptoms at three hours with a blood sugar of 65 mg per decaliter, having fallen from a two-hour value of 165 per decaliter.

If disclosed, any underlying anatomical disorder in a patient demonstrating hypoglycemia should be treated. In those who have no evident etiology, dietary management (to include high-protein, six-meal diet) should be employed. Appropriate control of hypoglycemic episodes must be attained prior to the patient's return to an "up" status; such control may take six months or more to achieve. In those aviators with continued episodes while under optimal dietary management, permanent grounding may be in order.

Hyperlipidemias

Classification of Hyperlipidemias. Hyperlipoproteinemias may be classified into five groups on the basis of plasma appearance and electrophoretic pattern, serum cholesterol, and triglyceride concentration.

1. *Type I.* Type I is characterized by increased chylomicrons in the blood serum which produce a milky fasting serum. If the specimen is allowed to stand at 4° C overnight, lactescence will rise

like cream, leaving a transparent infranate. Triglyceride levels of 1,000 to 10,000 mg per decaliter are seen. Ultralow density particles derived from the diet via lymphatics (i.e., chylomicrons), form a dense band on electrophoresis. The underlying abnormality appears to be a genetic defect (recessive trait) which results in a lipoprotein lipase deficiency. The disease may appear in early childhood and presents as abdominal pain, distention, and an increase of pancreatic enzymes. Xanthomas, hepatosplenomegaly, and lipemia retinalis may be present.

2. *Type II.* Type II accounts for a sizable number of individuals who are identified by an elevation of serum cholesterol. Familial Type II is an autosomal dominant trait, and evidence is strong for the presence of accelerated vascular disease. In the homozygous state, coronary artery disease may express itself in childhood. Tendinous xanthomas of the Achilles tendon or other extensor tendons may occur. Tuberos xanthomas over the elbow, knees, buttocks, and hands are common. Xanthelasmas may be present, along with arcus comealis. Cholesterol is elevated, and the plasma is clear (Type IIA) to very slightly turbid (Type IIB). Electrophoresis shows a broad B-band (with a pre-B band in may Type IIB's).

3. *Type III.* Type III is probably an autosomal recessive trait. It is less common than Types II and IV. Both triglycerides and cholesterol are moderately elevated, and serum allowed to stand overnight at 4° C takes on a moderately turbid appearance. A dense, broad B-band (generally fused with a pre-B band) is present on electrophoresis. Xanthomas, xanthelasmas, and corneal arcus may be present.

4. *Type IV.* Type IV is probably the most common lipid disturbance in the adult American Population. It is clearly exacerbated by obesity and alcohol; two-thirds of the patients have glucose intolerance. Cholesterol is normal to slightly elevated; triglyceride levels range from 200 to 2000 mg per decaliter. A dense pre-B band is present on electrophoresis; serum takes on a turbid appearance overnight at 4° C. Fasting plasma lactescence may be present, indicative of "hepatic particles" (triglycerides synthesized in the liver). Xanthomas, corneal arcus, and premature vascular disease may develop, depending upon lipid levels, at least in part.

5. *Type V.* Type V patients have both elevated cholesterol and triglycerides. The triglycerides, themselves, are an admixture of chylomicrons and hepatic particle triglycerides. Obesity, abdominal pain, pancreatitis, lipemia retinalis, and xanthomas are common. The trait is likely recessive. Dense chylomicron, B-, and pre-B-bands are seen on electrophoresis; plasma after overnight refrigeration separates into a cream-layer supernatant and a milky infranantant.

Treatment. Diet is the fundamental treatment for all forms of hyperlipidemia. A basic diet such as the following can be adapted for individual conditions:

1. Caloric reduction to attain ideal body weight.
2. Reduction in cholesterol intake to less than 300 mg/day.
3. Reduction in fat intake to 30 to 35 percent of total calories.
4. Decrease in saturated fat to no more than 10 percent of calories.

Patients with hypercholesterolemia may need further reduction in cholesterol intake and patients with hypertriglyceridemia often need more stringent weight and alcohol reduction.

The hyperlipidemias, particularly hypercholesterolemia, are risk multipliers for coronary artery disease and the management of these conditions in aviators should emphasize the overall cardiac state.

Obesity

Almost all cases of obesity are due to exogenous factors, specifically caloric intake in excess of caloric expenditure. Other causes are not worthy of review; neither will space be taken to reproduce weight standards for aviation.

For case of calculation, one can utilize the figure of 3500 calories as equivalent to one pound of body fat. Multiplication of 3500 by the number of pounds in excess of standards (or desired weight) results in calculation of total number of calories in excess. For example, a 73-inch male weighs 219 pounds, which is ten pounds over maximum aviation weight standards for height; $3500 \text{ cal./lb} \times 10 \text{ lbs.} = 35,000$ calories in excess. To calculate rate of loss, maintenance caloric intake is first figure by multiplying present weight 219 lbs. $\times 10$ (cal./lb.). Therefore, 2190 cal./day are required in order to maintain weight. Maintenance caloric intake minus specified caloric-restricted diet provides the daily caloric deficit. In this instance, an 1800 calorie diet is ordered, giving a daily caloric deficit of 390 calories (2190-1800). The deficit is divided into the total caloric excess, thereby calculating the number of days required to lose the excess weight (i.e., $3500 \text{ cal./}390 \text{ cal./day} =$ approximately 90 days). The desired weight can be maintained, thereafter by 2090 cal./day (209 lbs. $\times 10$ cal./lb.).

In essence, obesity is almost uniformly exogenous in etiology; most other causes are readily diagnosed by physical examination and through historical information. Weight loss requires insight and determination on the part of the patient, but it also requires concern and support (including referral of patient and spouse to the dietitian) on the part of the physician. The results of

Internal Medicine

patient effort and participation are easily seen and can be monitored by a simple device, the scale. Obese patients should be grounded until the desired weight is attained; follow-up to observe continued maintenance of desired weight is necessary and should include grounding if interval weight gain is present.

Obesity in the Navy is defined in relation to the percent of body fat. The equation of Wright, Dotson and Davis is used to estimate the percent body fat in males. A nomogram was developed at NAMI from this equation for easy determination of body fat and is included at the end of this chapter. Body fat equations are available for women, also, though due to the added variables needed to yield adequate correlations to immersion weighing, are not easily reduced to nomogram format. Methods and tables for determining body fat in women are also included at the end of this chapter.

Standards for maximum allowable body fat for men and women of the Navy and Marine Corps change periodically and are subject to the regulations of the respective services. Reference should be made to the current applicable instructions of each service when using the measurement of body fat for administrative purposes (OPNAVINST 6110 and MARINE CORPS ORDER 6100 series).

SECTION V: PULMONARY DISEASE

Pulmonary Function Testing

Although a great deal can be learned about the lungs from the history, physical examination, and chest X-ray, pulmonary function testing can be a useful adjunct to describe and quantify many properties of the respiratory system. Several of the more important and simple tests will be discussed here and applicability to aviation medicine situations will be noted.

Volume-Time Spirometry

Volume-time spirometry measures the traditional forced vital capacity maneuver (Figure 5-18). A diminution of the vital lung capacity represents significant restrictive disease of the lung (e.g., collapse, infiltrates, chest wall deformities, or neuromuscular dysfunction). The amount of air expired in the first second of this forced maneuver (FEV_1) is the classical, but insensitive, indicator of airway obstruction (e.g., significant bronchitis, acute asthma). These tests may be useful in following the recovery from reversible lung disorders in pilots, but their insensitivity makes their use as a screening tool unwarranted.

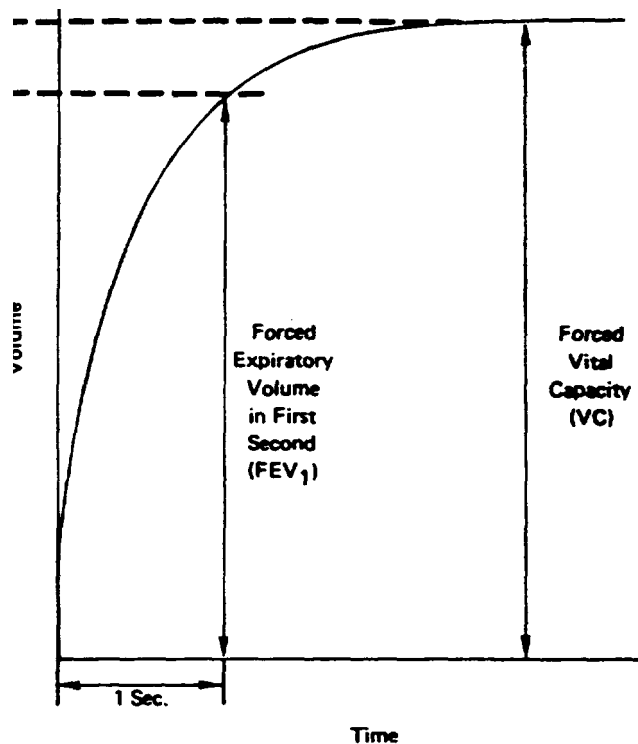

Figure 5-18. Graph of forced volume-time spirometry.

Flow Volume Spirometry

This test (Figure 5-19) uses the same forced vital capacity maneuver as volume-time spirometry, but here the flow rates are measured and plotted against the percentage of vital capacity expired. This is useful for measuring the mid- and end-expiratory flow rates, so difficult to determine from the volume-time curve. It is these flow rates that are felt to be sensitive indicators of airway dysfunction in otherwise asymptomatic individuals. Presumably, abnormalities here reflect a predisposition to subsequent obstructive pulmonary disease. Thus, these measurements are potentially useful screening tools to identify high risk groups in an effort to alter their pulmonary stress factors (e.g., smoking, environment). Newer techniques comparing flows at room air versus flows using helium may enhance their effectiveness.

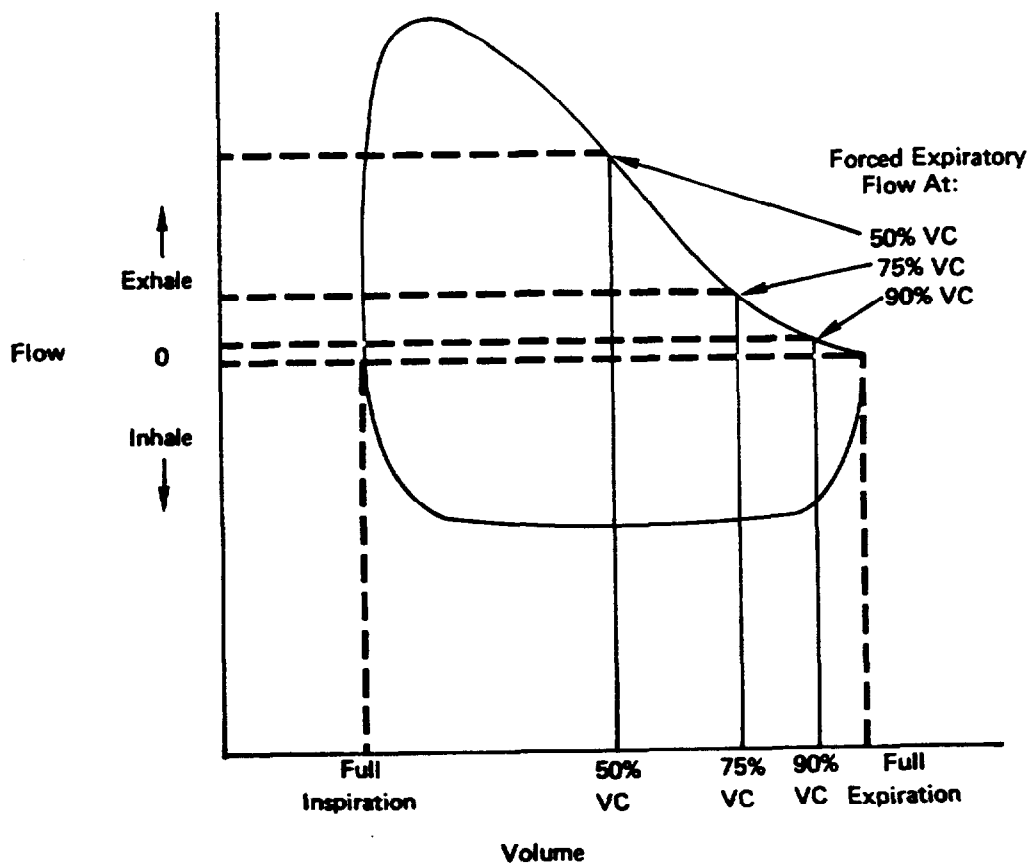

Figure 5-19. Graph of flow-volume spirometry.

Single Breath Closing Volume

Like the mid- and end-expiratory flow measurements described, this test is thought to be a simple and accurate indicator of early airway dysfunction. The procedure measures the dilution of residual nitrogen in the lung after a single breath of 100 percent oxygen. Airway dysfunction and collapse give a characteristic uneven dilution profile through expiration.

Maximum Mid-Expiratory Flow Rate

The maximum mid-expiratory flow rate (MMEFT), also called the forced expiratory flow through the 25th through 75th through 75th part of the vital capacity (FEF_{25-75}), has been found to correlate well with the closing volume and is an easy way to measure the function of the small airways from the simple spirogram. It also represents a relatively effort-independent portion of the expiratory cycle.

Diffusing Capacity

This test does not depend upon airway function but rather measures the permeability of the alveolar capillary membrane by use of carbon monoxide inhalation and uptake measurements. It is useful in describing dysfunction in interstitial diseases of the lung such as sarcoid or the pneumoconioses. It can be of help in following the recovery of a pilot from a reversible disorder, but has little screening potential.

Arterial Blood Gases

These measurements, particularly if done at near maximal exercise, give a good indication of overall pulmonary function as ventilatory, diffusing, and perfusion capabilities of the lung all come into play.

Aviation Effects on Pulmonary Function

The safe and effective operation of a combat aircraft stresses the oxygen delivery system to its limits. Oxygen demand may rise by a factor of 15 in certain high performance situation. The oxygen demand is met by a greater extraction of oxygen from the hemoglobin (the shape of the oxygen-hemoglobin dissociation curve allows this to happen with a minimal drop in PO_2). However, much of this demand must be supplied by an increased cardiac output coupled with an increased pulmonary oxygen delivery.

The pulmonary role can be divided into several steps. First, adequate oxygen must be available in the environment. Secondly, airways must be open and functional. Thirdly, the alveolar capillary membrane must allow efficient diffusion of oxygen. And lastly, pulmonary blood flow must not only be of a sufficient magnitude, but it must be appropriately matched to ventilated alveoli.

Immediate or Short-Term Effects

High G-Forces. The effects of high G-force can alter several of these pulmonary functions. First, it can both reduce, as well as redistribute, pulmonary blood flow to dependent lung fields. Secondly, it can cause collapse of these same dependent lung fields (atelectasis). The collapse of dependent alveoli is further encouraged if the alveolar gas is 100 percent oxygen rather than air containing mostly nitrogen since oxygen is readily absorbed across the alveolar membrane. The net effect of these alterations is both a decrease in vital capacity and an effective matching of blood and air, producing a significant compromise in the lung's ability to deliver oxygen.

Due to the pulmonary changes described above, tactical aviators often experience symptoms of dyspnea and cough following high G flights such as air combat maneuvers (ACM's). Physical examination during the symptomatic period reveals rales and chest X-ray may show basilar atelectasis. The condition rapidly clears and leaves no residua. Deep breathing, cough and reassurance are the treatments.

This clinical entity has been called aeroatelectasis, postflight atelectasis, or acceleration atelectasis. The combination of high G flight and oxygen breathing predisposes the aviator to aerotelectasis and since neither may or should be eliminated, education and awareness of this condition is necessary.

Chest Constraints. Chest constraints have small but significant effect on pulmonary function. The vital capacity is somewhat decreased and the work of breathing slightly increased by these devices.

Oxygen-Delivery Systems. Oxygen delivery systems are needed to maintain an adequate PO_2 in the inspired air while flying at altitude. However the dryness of the gas, the slight positive pressure, the possibility of contaminants, and perhaps the direct effect of 100 percent oxygen on the cilia and mucose, all contribute to airway irritation and transient airway flow measurement abnormalities following jet flights.

Long-Term Effects

It has always been thought that the vital capacity and flow measurement decreases immediately postflight reflected a totally reversible situation. Indeed, atelectasis, chest complaints, and volume-time spirogram abnormalities generally are resolved by 12 hours postflight. There are pathological and physiological data, however, that suggest that progressive, subtle, and permanent changes are occurring in the lungs of jet aviators. What the etiological factors are and what relationship, if any, these changes have to chronic lung disease remains to be explained.

Asthma

Asthma is a state of bronchial hyperreactivity to a number of stimulants. The classical childhood variety results from a characteristic I_gE allergic phenomenon. The less well understood "adult" variety develops later in life, has a less clear relationship to allergies (although nasal polyps and aspirin sensitivity are common), and seems more related to prolonged environmental stresses such as chronic infections, smoking, physical and chemical irritants, and anxiety states.

Most childhood asthma will spontaneously regress by young adulthood, but the Navy regulations disqualify the candidate whose symptoms have persisted past the age of 12. On the other hand, adult asthma develops in the age group containing already designated aviators. The future of such an individual is a difficult decision for the flight surgeon. In general, adult asthma usually stabilizes or improves with age, although a significant percentage of patients go on to develop chronic obstructive disease. Furthermore, the clinical picture runs a wide spectrum of severity. Thus, the approach should be individualized. The pilot with mild symptoms once a year during a bout of the flu, and with normal pulmonary function tests off medications the remainder of the time, need not be permanently grounded.

Conversely, severe attacks, permanently abnormal pulmonary function tests, and a need for chronic medication all constitute reasons for disqualifications.

Spontaneous Pneumothorax

Although uncommon, the acute spontaneous pneumothorax can strike any age group unpredictably and be acutely debilitating. Aviation candidates at risk (e.g., bullous disease, history of pneumothorax in previous years) are disqualified before entry into the flight program. Nevertheless, this does not eliminate all those at risk, for example, those with the presumed congenital alveolar defects that are not detectable clinically.

Internal Medicine

The acute episode may range from a sudden, mild pleuritic pain to a full cardiopulmonary arrest. Rest and analgesia are often all that is required for small pneumothoraces, but a chest tube for reexpansion may be required if large or seriously symptomatic.

Following a single, spontaneous pneumothorax, the risk of recurrent pneumothorax is high for at least one year (up to 30 percent). Because of this, aviators should be grounded for at least this period of time. A second pneumothorax is permanently disqualifying, unless surgical stripping or adherence of parietal and visceral pleura is done. In those postsurgical cases, exercise tolerance and pulmonary function testing must be normal before the patient is returned to flight status.

The air evacuation of patients with pneumothorax is discussed in Chapter 16, *Aeromedical Evacuation*.

Sarcoidosis

This is an interesting granulomatous disease of unclear etiology. It frequently presents as asymptomatic bilateral hilar adenopathy in routine chest X-ray. The disease, however, can produce interstitial lung disease, erythema nodosum, uveitis, liver function abnormalities, and depression of cellular immunity. Hypercalcemia, bone lesions, splenomegaly, and neurological symptoms are rarer. Diagnosis is made by biopsy (noncaseating granuloma). Asymptomatic hilar adenopathy alone is virtually diagnostic of the disease.

Acute sarcoidosis occurs in young adults and most will completely resolve within two years without sequelae. Steroids may be useful for transient control of symptoms. Following such a course, a return to flight status is reasonable providing ECG, exercise tolerance, pulmonary function, and all signs of the disease have returned to normal.

The more insidious and chronic form of sarcoidosis occurs in an older population with more severe pulmonary and extrapulmonary symptoms. Prognosis here is poor with few remissions. These individuals are generally disqualified from aviation.

Pulmonary Emboli

Emboli to the lung can result in syndromes ranging from mild pleuritis to an acute asthmatic attack to a sudden new supraventricular tachycardia to a cardiopulmonary arrest. The diagnosis should be suspected in those predisposed to thromboemboli (e.g., venous disease, autoimmune phenomenon, right heart endocarditis) in whom acute pulmonary problems develop. The diagnosis is made by a good history, findings of pleuritis, arterial oxygen desaturation, and evidence of a lung perfusion defect on scan or arteriogram.

The aviation future of individuals postemboli depends on two things. First, there must be no residual cardiopulmonary dysfunction as determined by exercise testing, pulmonary function, and 24-hour ECG monitoring. Second, the source of the emboli must be completely resolved.

Airway Burns

Hot irritant gases such as ammonia, nitrogen oxide, sulfur dioxide, and sulfur trioxide are common in smoke from burning material. Phosgene is another toxic irritant gas that is produced when carbon tetrachloride from fire extinguishers comes in contact with hot surfaces. Airway burns are produced by these substances when inhaled. The clinical spectrum ranges from mild dyspnea, and coughing to severe pulmonary edema and "shock lung." Furthermore, these serious complications may not appear until three to 72 hours after exposure.

Return to flight status is reasonable when symptoms clear, and testing of airway function and diffusing ability have returned to normal.

SECTION VI: INFECTIOUS DISEASE

Infectious disease in the aviation community is generally limited to the acute contagious infections because of the young age group, requirement for excellent physical conditioning, aggressive preventive medicine programs, and the semiclosed population. These infections include the more common viral diseases, venereal diseases, tuberculosis, *Neisseria meningitidis*, and protozoa. Two handbook references that are continuously current are the *Handbook of Antimicrobial Therapy* and the *Guide of Antimicrobial Therapy*. The infectious disease section in *Harrison's Principles of Internal Medicine* is an excellent textbook reference. In general, the rigid demands of the aviator require that he be grounded while symptomatic and for 24 hours after completion of medical therapy.

Viral Disease

Viral disease in the aviation community is a major cause of "down" time. This category includes upper respiratory infection, influenza, infectious mononucleosis, and hepatitis. Treatment is symptomatic with observation for complication. With an infection of viral etiology, prophylactic antibiotic therapy should be withheld because of the risk of secondary infection with a resistant organism, toxicity of drugs, expense, and confusion with improperly treated bacterial infections. Antibiotic prescription in these situations is a poor substitute for frequent clinical observation and appropriate cultures. If bacterial etiology is suspected, cultures should be taken and antibiotic therapy begun. This should be terminated in five days if clinical or culture results are negative.

Upper Respiratory Infection

Rhinorrhea, pharyngitis, and sinus congestion compromise the patency of the Eustachian tube and, in the aviation environment, predispose to middle ear disorders such as vertigo or bacterial infection. Treatment is symptomatic with rest, increased fluids, and antihistamine therapy. The aviator is grounded until he has been off medication for 24 hours and proof of normal tympanic membrane motion is obtained. In recurrent illness, an allergic process should be sought. Secondary complications including otitis media, sinusitis, or bronchitis increase "down" time.

Influenza

The military community is considered a high risk group for influenza. There are three types of influenza virus, labeled A, B, and C. Influenza C causes mild upper respiratory infection symptoms. Influenza B causes mild flu symptoms. Influenza A causes the major epidemic at two to

four year intervals, and its antigenic changes result in morbidity and mortality as recorded in the epidemics of 1918 - Swine flu, 1957 - Asian flu, and 1968 - Hong Kong flu. BUMED recommendations for vaccination are reviewed yearly to reflect the situation actually present for that year. The vaccination program should be scheduled so that the entire unit is not incapacitated at the same time. The aviator is down for at least eight hours and preferably for 24 hours post-vaccination with observation for acute anaphylactic reaction and influenza syndrome.

The incubation period is less than three days, and the acute symptoms last an average of three days. During an acute episode, the aviator is in a "down" status and treated symptomatically with rest, analgesics, increased fluids, and observations for secondary complications, mainly bacterial pneumonia. Prophylactic antibiotic and amantadine therapy are not recommended. Cigarette smoking has been shown to be a major risk factor for acquiring influenza and determining the subsequent morbidity from infection. In an unusual epidemic situation, the infectious disease department of the regional medical center or the Communicable Disease Center should be contacted for guidelines on the need for typing of virus and the vaccination programs.

A special awareness is required to assess the impact of influenza on the readiness of the aircrewmen to resume flying duties in the presence of the ill-defined, but important, postinfluenza syndrome characterized by nonspecific fatigability and vague lassitude. In such an instance, where physical examination and laboratory values are normal, return to flight status should be delayed pending resolution of the syndrome complex.

Infections Mononucleosis

The clinical syndrome of fever, pharyngitis, lymphadenopathy, and lymphocytosis with many atypical lymphocytes in the young adult suggests mononucleosis caused by the Epstein-Barr virus. It warrants a mononucleosis heterophile test, and if negative, the test should be repeated in two weeks for confirmation. The acute illness lasts from two to four weeks with gradual return to full capacity. Treatment is symptomatic with rest, analgesics, and observation for complications which include airway obstruction, aseptic meningitis, encephalitis, Guillain-Barre syndrome, and splenic rupture. Prednisone 40 to 60 mg g.d. is recommended for treatment of these severe complications.

The aviator is in a "down" status until he is returned to normal activity following convalescence. A medical board or convalescent leave may be necessary in protracted cases. The persistent presence of a peripheral right shift or splenomegaly as the only disease residual in clearly recuperating patients constitutes objective evidence that the patient is not yet ready for aviation duties.

Hepatitis

Acute viral hepatitis is a commonly encountered clinical problem in operational medicine. The outcome and course of many military operations have been measurably altered by hepatitis outbreaks. Since 1968, knowledge of the etiological agents responsible for the symptom complex of anorexia, nausea, right upper quadrant pain and tenderness, hepatomegaly, jaundice, and elevation of AST and ALT enzymes (formerly called SGOT and SGPT) has become much more precise.

The two principal viral agents, hepatitis A virus (HAV), and hepatitis B virus (HBV), are responsible for the vast majority of cases worldwide. The former, spread by the fecal-oral route, is much more likely to be responsible for outbreaks of epidemic proportions and is amenable to prophylactic measures including steps to ensure proper handling of food, water, and human wastes. The prophylactic administration of Human Immune Serum Globulin is discussed below. HBV, formerly called "serum" hepatitis, presents less of a problem but is less amenable to large scale prophylactic measures. Both forms of hepatitis have become endemic in homosexual male populations and are now considered sexually transmitted diseases.

In 1982, the FDA released the HBV vaccine. BUMEDINST 6230.13E outlines the preliminary recommendations for use of the HBV vaccine.

Serology. Both forms of acute viral hepatitis have serological markers which enable the clinician to distinguish between the viral causes of virtually identical clinical presentations, thus helping to predict chronic sequelae and infectivity in HBV infections.

1. *HAV* In virtually all cases of acute hepatitis from HAV, an abrupt rise in antibody to HAV of an IgM subclass is measureable. The detection of this antibody rise is both highly sensitive and specific when associated with the appropriate clinical presentation. The Ig subcomponent also seen in most cases of HAV hepatitis appears later and has neither the sensitivity nor the specificity to distinguish the various causes of elevation of AST and ALT because the antibody elevation usually persists for years. Neither the IgM nor the IgG anti-HAV have any significance in predicting infectivity which usually ends with the onset of clinical symptoms.

2. *HBV.* In contrast to HAV, HBV has a plethora of serological viral markers which have both diagnostic as well as prognostic significance. Table 5-11 list the various serological markers for HBV and depicts the source of those particles.

Table 5-11

Seriological Markers for HBV and Their Sources

<i>Serological marker</i>	<i>Source/Significance</i>
Hepatitis B surface antigen (HB _s Ag)	Antigenic determinant found in the HBV viral coat; present during acute and chronic HBV infections.
Hepatitis core Antigen (HB _c Ag)	Antigenic component of double stranded DNA core; generally not directly detectable.
Hepatitis e Antigen (HB _e Ag)	Released from wre during viral replication; directly correlates with HB infectivity.
Hepatitis B surface Antibody (HB _s Ab)	Reflects immune response to HBV infection; directed against surface antigen.
HBV Core Antibody (HB _c Ab)	Core antibody is an immune response to viral replication. An IgM _c Ab reflects acute infections while an IgG _c Ab reflects old or chronic infection.
Hepatitis B e Antibody	Antibody directed against e antigen, reflects decreasing viral replication and beginning of resolution of the infection.

The clinical interpretation of the serological markers for HBV is summarized in Table 5-12.

3. *Non-A/Non-B Hepatitis.* To date, there are no serological markers for this form of viral hepatitis which has so far been exclusively associated with blood transfusions. Thus the diagnosis is by exclusion in the appropriate clinical setting. Some evidence exists that screening blood donors with elevations of ALT/AST will substantially decrease the risk of subsequent infection with non-A/non-B hepatitis. Though the clinical course of non-A/non-B hepatitis is usual-

Internal Medicine

ly milder than hepatitis caused from HAV or HBV, a much larger percentage of infected persons go on to a chronic hepatitis.

Treatment and Medical Disposition. The standard clinical texts each present excellent monographs on the care of individuals with acute viral hepatitis. The majority of cases may be cared for in shipboard medical departments where inpatient facilities exist. With Fleet Marine units ashore, referral to first eschelon medical facilities with inpatient facilities is indicated. Considerations in the decision to medevac infected individuals include:

1. Severity of infection.
2. Logistical support of forward medical unit (e.g., is laboratory support available?)
3. Will future operational requirements preclude future medevac?
4. Does the infected individual present a risk to other members of the crew or unit?

The usual course of acute viral hepatitis is six to 10 days of acute symptoms associated with a variable rise in ALT/AST and bilirubin. In individuals with fulminant infections, the prothrombin time will increase which is a poor prognostic sign.

If the clinical course is benign, the patient may return to activities as tolerated as soon as his appetite returns. Complete normalcy of AST/ALT is not a prerequisite for return to duty. While cases must be individualized, excessive convalescent leave is rarely indicated. Adequate outpatient follow-up, though, is mandatory in HBV infections.

Serological markers to follow include HB_sAg, and HB_cAb if persistently positive HB_sAg exists. The AST and ALT should be followed at monthly intervals after the initial decline has been documented.

Human Immunodeficiency Virus (HIV)

The human immunodeficiency virus is a retrovirus which was recognized as an infectious cause of an unusual immunodeficiency syndrome in otherwise healthy homosexual males in 1982. Since then, the virus has been recognized as a major public health problem for men and women, with between 5 and 10 million persons thought to be infected worldwide.

Table 5-12

Clinical Interpretation of Seriological Markers for HBV

Test						Interpretation
HB _s Ab	HB _s Ag	HB _e Ag	HB _e Ab	HB _c Ag (total)	HB _c Ag (IgM)	
+	-	-	-	-	-	Incubation or early acute HBV infection
+	-	+	-	-	-	Early acute HBV infection
+	-	+	-	+	+	Acute HBV infection
+	-	-	±	+	+	HBV _s Ag "window" of acute HBV infection
-	-	-	+	+	+	convalescence
-	+	-	+	+	+	Early recovery (up to 8 months)
-	+	-	+	+	-	Recovery (after 8 months)
+	-	±	±	+	-	Chronic HBV carrier, chronic hepatitis
-	+	-	-	-	-	Old HBV with indetectable core or e antibody levels

Internal Medicine

HIV is transmitted in a similar mode to that of hepatitis B virus; it can be acquired by homosexual or heterosexual intimate contact, by receiving infected blood or blood products, or by inoculation via needles contaminated with infected blood (IV drug use, tattooing, etc.). There is good evidence that transmission via open skin wounds exposed to infected blood or saliva occurs, but such transmission is rare.

Pathogenesis and Complications. HIV infects predominantly T₄ (helper) lymphocytes and macrophages. These cells express the CD4 surface antigen to which the virus surface glycoproteins bind. Once bound, the virus inserts its RNA genome into the cell which undergoes reverse transcription to viral DNA. This DNA is then incorporated in the host genetic material where it can either remain dormant, express new viral RNA to make new virus, or possibly serve as an oncogene.

The destruction of infected lymphocytes and other immune cells results in a state of immunodeficiency. Some patients experience a flu-like illness when initially infected, but often there are no symptoms. A very variable, prolonged period may pass in which there are no signs or symptoms as immunosuppression proceeds. When the immune system is sufficiently impaired, infections with various organisms usually not pathogenic occur. These so-called opportunistic infections include fungi (*Cryptococcus neoformans*, *Histoplasma capsulatum*, *Candida* species, etc.) viruses (*Herpes* species, *Cytomegalovirus*, *Varicella*, etc.), bacteria (*Mycobacterium tuberculosis*, *M. avium*, encapsulated organisms, etc.), and parasites (*Pneumocystis carinii*, *Giardia* species, *Toxoplasma gondii*, etc.).

No curative therapy exists at this time for HIV infection. Therapy is directed at treatment of complications, and some progress is being made in antiviral therapy. Although it is beyond the scope of this discussion, excellent reviews are available in the standard textbooks of Internal Medicine reviewing pathogenesis, complications, and management of HIV infection.

One complication that bears specific mention is a global dementia that occurs in the absence of an opportunistic infection of the CNS. This appears to be a direct consequence of HIV viral infection and precedes any other clinical manifestation in between 10 and 25 percent of infected patients who develop AIDS. Initially, there are mild cognitive defects involving judgement and memory, which progress to a severe global dementia. In light of this complication, HIV infection regardless of symptoms or signs is disqualifying for all special duty including aviation-related duties.

Disposition of HIV Positive Individuals. Screening of all applicants to military service is performed using enzyme linked immunosorbent assay (ELISA) to detect antibodies to the virus in

U.S. Naval Flight Surgeon's Manual

patient serum. If positive, the test is repeated. A positive repeated test is confirmed using a Western blot technique for specific antibodies before a patient is identified as "HIV-positive".

HIV positivity, thus defined, is disqualifying for enlistment and commissioning in the armed forces. Seroconversion while on active duty requires an inpatient evaluation at a major treatment facility for classification, according to the Walter Reed Staging System outlined in Table 5-13.

Table 5-13

Walter Reed Staging System

WALTER REED/DOD STAGING SYSTEM						NAVY CATEGORY	
HIV Ab A/O VIRUS	CHRONIC ADNP Thy	T-HELPER CELLS	DHS	THRUSH	OI		
1	◊ +	-	> 400	WNL	-	-	A
2	+	◊ +	> 400	WNL	-	-	A
3	+	+/-	< 400	WNL	-	-	B
4	+	+/-	< 400	◊ P	-	-	INCLUDES ARC
5	+	+/-	< 400	◊ P/C a/o +/-		-	
6	+	+/-	< 400	P/C	+/-	◊ +	C INCLUDES AIDS

KEY: DHS- delayed hypersensitivity testing, OI- opportunistic infection

As mentioned previously, *all* seroconverters are permanently disqualified from all special duties, including aviation. Patients in Navy Category A (asymptomatic, with normal T₄ cell numbers) may continue serving their obligated service period in CONUS only and in nondeployable billets, but are ineligible for reenlistment. Any patient staged at Navy Category B or C is medically retired, as are Category A patients who progress to a higher category while on active duty.

Internal Medicine

Tuberculosis

Extensive instructions for testing, treatment, and disposition of tuberculosis (TB) cases are contained in NAVMED P-5052-20 and BUMEDINST 6224.ID. All cases of active TB are to be expeditiously transferred to a tuberculosis treatment center. These are NRMC, Portsmouth, Va., and NRMC, San Diego, Ca. A Disease Alert Report, MED-6220-3, is submitted.

The aviator is grounded for the duration of chemotherapy and then returned to active flying status if there are no residual physical disqualifying defects.

Preventative therapy of TB is based on the facts that transmission of TB is by aerosolized droplets and that the natural history of TB includes the reactivation of dormant disease. With discovery of an active case of TB, a contact investigation is begun. This includes all who share the same berthing facilities, those in close contact during duty hours, regular liberty mates, and dependents of patients. This is extended on ships to include the entire ship's company, if less than 350 onboard personnel, or crew members served by the same ventilation system, and in commands with exceptionally close conditions. Decontamination of affected spaces involves changing of filters in ventilation systems and cleaning of the patient's berthing spaces and bedding.

The screening examination for close contacts includes skin testing using five units of purified protein derivative (PPD) of tuberculin intradermally and chest X-ray with results recorded on NAVMED 6224/1 in the Health Record. Reexamination is done at three, six, and 12 months. Previous tuberculin reactors are screened with chest X-ray only. If no active disease is present, but PPD is greater than 10 mm, isoniazid (INH) 300 mg q.d. is given for one year unless contraindications exist. If the screening test is negative, isoniazid (INH) prophylaxis may begin based on the clinical situation, to be discontinued at three months if reexamination continues to be negative.

INH preventive therapy is a balance between the risk of reactivation of disease over a period of time and the risk of side effects, namely INH hepatitis. Current recommendations are to begin 12-month INH prophylaxis in the following cases:

1. PPD converter in the past two years.
2. Positive PPD with chest X-ray consistent with inactive TB, with negative AFB smear and culture, and without prior adequate chemotherapy.
3. Positive PPD with diabetes mellitus, hematological or reticuloendothelial disease, prolonged steroid therapy, immunosuppressive therapy, silicosis, and postgastrectomy.

4. Mandatory for PPD-positive children under six years and highly recommend to age 35 years, unless specific contraindications exist.

Specific contraindications to INH therapy include previous INH hepatic injury, adverse reaction to INH such as drug fever, chills, rash, and arthritis, acute liver disease of any etiology, and pregnancy. Special attention should be paid to people on long-term medications such as phenytoin, daily users of alcohol, patients with chronic liver disease, and those with a history of prior discontinuance of INH secondary to questionable reaction.

Individuals on INH chemoprophylaxis should be educated about toxic symptoms and queried monthly about signs and symptoms of hepatitis. Should they occur, the patient is instructed to immediately discontinue INH therapy and report for evaluation of liver disease. Routine liver function tests are not recommended. An isolated SGOT elevation less than 100 I.U. is not sufficient reason for stopping therapy.

The aviator is returned to flight status while receiving INH prophylaxis once the flight surgeon has established that no untoward reactions are ongoing. This may require an initial two-week grounding with biweekly clinical observation.

Malaria

Malaria is transmitted by the bite of the *Anopheles* mosquito and should be suspected in any ill person returning from an endemic area. The symptoms of chills, fever, headache, muscle pains, associated splenomegaly, and anemia should occur within three weeks of exposure.

The first attacks are severe, but repeated attacks become milder. The diagnosis is confirmed by finding parasitized erythrocytes on Wright's or Giemsa-stained smears. The parasites should be seen and diagnosed on at least one slide, if blood is obtained every six hours during a 24-hour period. Associated laboratory findings are a normal or low white count and an elevated erythrocyte sedimentation rate.

Complications associated with malaria are spontaneous rupture of the spleen, bacillary dysentery, cholera, and pyogenic pneumonia. The treatment of acute attack generally consists of chloroquine, 0.6 gms initially, 0.3 gms six hours later, 0.3 gms daily times two, and pyrimethamine, 25 mg b.i.d. for three days. If a patient is suspected of having drug resistant *P. falciparum*, a combination of quinine, pyrimethamine, and sulfonamide or sulfones should be given for 10 days. To clear the liver of parasites as in *P. vivax*, *P. ovale* or *P. malariae*, a 14-day course of 15 mg. primaquine base will effect cure in most cases. Current and specific treatment

Internal Medicine

recommendations can be obtained from the Navy's Environmental and Preventive Medicine Units (EPMU's) or the CDC.

Prophylaxis regimes should be guided by current estimations of the prevalence and drug susceptibility of the malaria in each specific area. The EPMU or the CDC can provide this information also. Aviators may take chloroquine, primaquine or pyrimethamine/sulfadoxine (Fansidar^R) in prophylactic doses and continue in a flight status after clearance by the flight surgeon of allergic, idiosyncratic or other untoward side effects (i.e., G.I. intolerance, rash). Hemolysis in G-6-PD deficiency is most commonly associated with daily primaquine, however it has occurred with weekly primaquine as well as the sulfa drugs. Individuals with G-6-PD deficiency should be carefully observed for hemolysis when these drugs are used.

Amebiasis

The major protozoal diseases with world wide distribution are amebiasis and malaria. Both diseases are more common in underdeveloped tropical and subtropical countries, but they are also seen in military personnel and civilians returning from these areas.

Amebiasis is caused by *Entamoeba histolytica*. It is the only one of the seven different species which parasitize the mouth and intestine of man, causing disease. There are two forms of *Entamoeba histolytica*, the motile trophozoite and the cyst. The trophozoites are passed in the stool unchanged when diarrhea is present. If there is no diarrhea, the trophozoites will encyst before passage in the stool. It is the cyst which causes disease, and the usual route is through fecal contamination of food and water. The diagnosis is made by finding the cyst in formed stools or the trophozoite in liquid stool.

The clinical manifestations of symptomatic intestinal amebiasis are intermittent diarrhea, progressing to fulminant attacks of amebic dysentery with high fever, severe abdominal cramps, and profuse bloody diarrhea with tenesmus. In these patients, trophozoites are numerous in stools and on the material obtained from ulcers in the cecum and rectum. Hepatic amebiasis occurs as a result of the parasite invading of the liver via the portal vein. This may be followed by the development of a single hepatic abscess in the posterior portion of the right lobe of the liver. Clinical findings of the abscess are fever, night sweats, weight loss, and sometimes, tender hepatomegaly. Occasionally, an abscess will extend into the right pleural cavity and lung. These people will present with cough, pleural pain, fever and leukocytosis as a rule. A secondary bacterial infection is frequent.

Metonidazole (Flagyl^R) is the drug of choice for both intestinal and hepatic amebiasis. Aviators receiving any form of treatment for amebiasis should be grounded.

Traveler's Diarrhea

Acute diarrhea occurring with travel to developing regions of the world is the most common infectious disease limiting the operational effectiveness of the military. Enterotoxigenic *Escherichia coli* have been found to be the major pathogen in 40 to 70 percent of cases. *Shigella* is found in five to 20 percent, and less commonly, *Campylobacter*, Reovirus and Norwalk virus are isolated.

Treatment of traveler's diarrhea consists of generous fluid replacement and bowel rest (clear liquids). Pepto-Bismol^R in doses of two to four tsp. every half hour for eight doses has been shown to reduce the frequency and the severity of the diarrhea.

Prevention of traveler's diarrhea has been attempted with various agents. Pepto-Bismol^R, two tsp. twice a day prophylactically, appears to bind the enterotoxin and confer relative immunity. Doxycycline, 100 mg. daily, has also demonstrated effectiveness in preventing most acute traveler's diarrhea. Trimethoprim sulfa (TMP/SMX) prophylaxis may also be effective.

Widespread use of prophylactic antibiotics will undoubtedly induce bacterial resistance and is therefore not recommended. The risk of virulent superinfection is also present with routine antibiotic administration.

The synthetic opiates (diphenoxylate and loperamide) are often prescribed and may reduce fluid secretion from the bowel. Excessive use of these agents, however, may actually worsen the illness and prolong the carrier state.

Aviators with acute traveler's diarrhea should be grounded during the acute illness and while taking the opiate-type drugs. Under certain extenuating circumstances, the use of prophylactic antibiotics, though not generally recommended, may be consistent with continued flight status once the flight surgeon has determined that the aviator is free of untoward side-effects.

SECTION VII: RENAL DISEASE

Significant renal disease in the aviation community is limited to acute infection, asymptomatic or symptomatic hematuria, and nephrolithiasis which, if recurrent, may be disqualifying.

Urinary Tract Infection

It is rare for a male under the age of 50 years to get urinary tract infection. Other infectious processes such as gonorrhea and prostatitis should be ruled out. With clinical evidence of pyelonephritis, an obstructive process must be ruled out with the IVP. The infecting organism should be documented with cultures, and sensitivities should be obtained to guide antibiotic selection. The aviator is grounded until 24 hours after completion of therapy. In cases of recurrent infections, infection with an unusual organism such as *Proteus* or *Pseudomonas*, or evidence of obstructive process, referral for complete urological evaluation is recommended.

Hematuria/Proteinuria

The discovery of hematuria/proteinuria in an asymptomatic individual on routine screening urinalysis requires that an etiology be determined. Initially, the test should be repeated ensuring that proper collection technique is followed. A three bottle collection may be helpful with the because the upper tract etiology will show consistent abnormality with the lower tract only at the beginning or end of collection. Benign etiologies include postural proteinuria, proteinuria following intercourse, hematuria/proteinuria following vigorous exercise, and certain febrile illnesses. Infection is the most common etiology. Other etiologies in order of decreasing frequency include neoplasm, trauma, calculi, glomerulonephritis, and bleeding disorders. Evaluation of blood urea nitrogen, serum creatinine, and 24-hour urine for creatinine, total protein, and total volume, serum uric acid, serum protein electrophoresis, serum complement, fluorescent antinuclear antibody, prothrombin time, partial thromboplastin time, and IVP gives an assessment of renal function and some diagnostic information.

Symptomatic patients, and asymptomatic patients (if it is necessary to establish the diagnosis), should be grounded and promptly referred to a urologist or nephrologist for a complete evaluation. The aviator's status depends upon the underlying disorder (e.g., glomerulonephritis may be self-limiting). If the condition is benign or self-limiting, the aviator is returned to flight status, whereas a progressive neoplasm or renal disease will render a patient permanently NPQ.

Nephrolithiasis

Nephrolithiasis is a vexing problem in the aviation community. The risk to be appreciated by the flight surgeon is sudden incapacitation in flight which applies with equal importance, but differing implications to all aircrewmen. In symptomatic airmen or applicants presenting with a history of renal stones, the stone screening battery should be obtained.

Stone Screening Battery (Drach Protocol)

- Urinalysis
- Urine culture
- C B C
- Serum electrolytes
- Serum Ca + + , PO_4 , uric acid
- 24 - hr. urine for
CA + + , PO_4 , uric acid
- Nephrotomograms
- IVP
- Stone analysis
- Urine pH (meter) (if available)
- Cysteine screen (if available)

Other Tests

Additional studies such as parathormone assay, renal scan, and urinary oxalate measurements as well as urological evaluation may be indicated on an individual basis.

Disposition

Designated aviators with nephrolithiasis should be grounded. If the metabolic work-up is negative, the aviator may be returned to unrestricted flight status two weeks after spontaneous passage of the stone, four weeks following stone manipulation, or three months following open surgery.

If the metabolic work-up is positive and the underlying process is treatable, a waiver should be submitted and the aviator may be returned to a SG-III flight status for three months for evaluation of adverse medication side-effects. After that period, and with clearance from the flight surgeon the aviator may return to SG-I.

Internal Medicine

If the metabolic work-up is positive and the process is not treatable or the aviator has retained stones, he is permanently grounded. Cases with frequent recurrences (generally more than two a year or three in five years) or retained parenchymal stones should be submitted for waiver by BUMED and considered on a case-by-case basis.

Applicants for aviation duty with a history of renal calculi will be considered only if the metabolic work-up is negative, there are no retained calculi, and a year has passed since the stone passage.

SECTION VIII: MALIGNANCY

With earlier detection combined with improved and aggressive combinations of surgical therapy, chemotherapy, immunotherapy, and radiation therapy, there are increased numbers of long-term survivors and apparent cures of malignancies (e.g., Hodgkin's lymphoma). Moreover, there is expected to be further improvement with present investigative programs. However, survivors of childhood cancer will often have a residual deformity that renders them NPQ for aviation. For survivors without physical impairment, type of tumor, therapy given, current prognosis, and need of the aviation community will have to be individually considered. Ideally, entrance into the aviation community will require that the patient be considered permanently cured after more than five years after definitive therapeutics with no residual physical impairment.

The designated aviator who is one year past a major therapeutic program, resulting in a permanent cure, and with no residual disqualifying physical impairment should request a waiver for placement back to flight status.

REFERENCES AND BIBLIOGRAPHY

- Abramovicz, M. (Ed.) *Handbook of antimicrobial therapy*- New Rochell, N.Y.: The Medical Letter on Drugs and Therapeutics, 1985.
- Alavi, J.B. Sickle cell anemia: Pathophysiology and treatment. *Medical Clinics of North America*, 1984, 68, 545-556.
- Bates, D.V., Macklem, P.T. & Christie, R.V. *Respiratory function in disease*. Philadelphia: W.B. Saunders, 1971.
- Beumer, H.M. A ten year review of spontaneous pneumothorax in an armed forces hospital. *American Review of Respiratory Diseases*, 1964, 90, 261.
- Berenson, A.S., *Control of communicable diseases in man* (14th ed.). Washington, D.C.: American Public Health Association, 1985.
- Braunwald, E., Isselbacher, K.J., Petersdorf, R.G., Wilson, J.D., Martin, J.B., & Fauci, AS. *Harrison's principles of internal Medicine* (11th ed.). New York: McGraw-H& 1987.
- Bruce, R.A. Exercise testing of patients with coronary heart disease. Principles and normal standards for evaluation. *Annals of Clinical Research*, 1971,3, 323-332.
- Castell, D.O., The lower esophageal sphincter: Physiological and *clinical aspects*. *Annals of Internal Medicine*, 1975, 83, 390-401.
- Clark, J.M., & Lambertson, C.J. Pulmonary oxygen toxicity, a review. *Pharmacological Review*, 1971, 23, 37-133.
- Cooper, D.S. Antithyroid drugs. *New England Journal of Medicine*, 1984,311, 1353-1362.
- Department of the Navy, Bureau of Medicine and Surgery. *Manual of the Medical Department* (NAVMED P-117). Washington, DC, 1980.

Internal Medicine

- Department of the Navy, Bureau of Medicine and Surgery. The diagnosis and management of tuberculosis. (NAVMED P-5052-20). Washington, DC, 3 February 1973.
- Department of the Navy, Bureau of Medicine and Surgery. Tuberculosis control program (BUMEDINST 6224.1D). Washington, DC, October 1986.
- Dreifus, L.S. (Ed.). Cardiovascular problems associated with aviation safety: Eighth Bethesda conference of the American College of Cardiology. *American Journal of Cardiology*, 1975, 36, 573-628.
- Dodds, W.J., et.al. Pathogenesis of reflux esophagitis. *Gastroenterology*, 1981, 81, 376.
- DuPont, H.L., et.al. Treatment of traveller's diarrhea with trimethoprim-sulfamethoxazole and with trimethoprim alone. *New England Journal of Medicine*, 1982, 307, 841-844.
- DuPont, H.L., et-al. Chemotherapy and chemoprophylaxis of traveller's diarrhea. *Annals of Internal Medicine*, 1985, 102, 260-261.
- Fanta, C.J., Rossing, T.H., & McFadden, E.R. Treatment of acute asthma. *American Journal of Medicine*, 1986 80, 5.
- Gitnick, F.L., Goldberg, L.F., Korentz, R., & Walsh, J.J. The liver and antigens of hepatitis B. *Annals of Internal Medicine*, 1976, 85, 488-496.
- Goldstein, R.A., (Ed.). Advances in the diagnosis and treatment of asthma. *Chest*, 1985, 87, 18-113s.
- Gregory, P.B., Knauer, C.M., Kempson, R.L., & Miller, R. Steroid therapy in severe viral hepatitis. *New England Journal of Medicine*, 1976, 294, 681-687.
- Hamrick, R.M., & Yeager, J., Jr. Tuberculosis update. *American Family Practice*, 1988, 38, 205-213.
- Ho, B.L. A case of spontaneous pneumothorax in flight. *Aviation, Space, and Environmental Medicine*, 1975, 46, 840-841.
- Holt, K.M., & Isenberg, J.I. Peptic ulcer disease: Physiology and pathophysiology. *Hospital Practice*, 1985, 20, 89.
- Ingbar, S.J. The thyroid gland. In Wilson, J.D., & Foster, D.W. (Eds.), *William's textbook of endocrinology* (7th ed.). Philadelphia: Saunders, 1985. 730-733.
- Jones, N.L. Exercise testing in pulmonary evaluation. *New England Journal of Medicine*, 1975, 293, 647-650 and 864-865.
- Jones, S.R., Binder, R.A., & Donowho, E.M., Jr. Sudden death in sickle cell trait. *New England Journal of Medicine*, 1970, 282, 323-325.
- Kilbourne, E-D., (Ed.). *Influenza virus and influenza*. New York: Academic Press, 1976.
- Leavall, B.S. & Thorup, O.A. *Fundamentals of Clinical Hematology* (3rd ed.). Philadelphia: Saunders, 1971.
- Marriot, H.S. *Practical electrocardiography* (7th ed.) Baltimore: Williams and Wilkins, 1983.
- Mills, J. Update in the management of enteric infections. *Modern Medicine*, 1988, 56, 115-124.
- Morris, J.G., & Black, R.E. Cholera and other vibrioses in the United States. *New England Journal of Medicine*, 1985, 312, 343-350.
- National Diabetes Data Group. Classification and diagnosis of diabetes mellitus and other categories of glucose intolerance. *Diabetes*, 1979, 28, 1039-1057.
- Resenkov, L. (Ed.). The cardiac disturbances. *Medical Clinics of North America*, 1976, 60, Part I and Part II.
- Rose, D.N., Schlechter, C.B., & Silver, A.L. The age threshold for isoniazid chemoprophylaxis. A decision analysis for low risk tuberculin reactors. *Journal of the American Medical Association*, 1986, 256, 2709-2713.

U.S. Naval Flight Surgeon's Manual

- Ross, D.S. New sensitive immunoradiometric essays for thyrotropin. *Annals of Internal Medicine*, 1986, 104, 718-720.
- Slesinger, M.A., & Fordtran, J.S. *Gastrointestinal disease, pathophysiology diagnosis, and management* (3rd ed.). Philadelphia: Saunders, 1983.
- Standards for cardiopulmonary resuscitation and emergency cardiac care. *Journal of the American Medical Association*, 1974,227, 833-868, Supplement.
- Stead, W.W. Benefit -risk considerations in preventive treatment for tuberculosis in elderly persons. *Annals of Internal Medicine*, 1987, 107, 843-845.
- Strumm, W.B., Update on traveller's diarrhea. *Postgraduate Medicine*, 1988, &, 163-170.
- Sunder-am, G., et.al. Tuberculosis as a manifestation of the acquired immunodeficiency syndrome (AIDS). *Journal of the American Medical Association*, 1985, 25, 362-366.
- The Expert Panel: Report of the National Cholesterol Education Program Expert Panel on detection, evaluation, and treatment of high blood cholesterol in adults. *Archives of Internal Medicine*, 1988, 148, 36-69.
- Treatment of Malaria. *Medical Letter on Drugs and Therapeutics*, 1988, 301, (759), 21-24.
- What science knows about AIDS. *Scientific American*, 1988, 249, (4), Entire issue.

CHAPTER 6

AVIATION PSYCHIATRY

Introduction

The Context

The Psychology of Flying

The Psychopathology of Flying

Psychopathology in the Military

Psychiatric Evaluation

Psychological Testing

The Psychiatric Report

The Evaluation of Candidates

The Evaluation of Students

Evaluation of Designated Flight Personnel

Aeronautical Adaptability

Administrative Psychiatry

Treatment Modalities

Psychoses

Depressions - Mood Disorders

Anxiety Disorders

Sleep and Insomnia

Psychiatric Emergencies and Suicide Prevention

Drug Overdose

Family Crises

Combat Psychiatry

The Psychology of Survival and the Repatriated Prisoner of War

References and Bibliography

Appendix 6-A - Outline for Psychiatric Reports

Appendix 6-B - Psychiatric Standards - Guidelines for Naval Aviation

Introduction

Naval Aviation Psychiatry is a unique blend of psychodynamics, operational medicine, general medicine, and common sense gleaned from extensive operational experience. This chapter is a

U.S. Naval Flight Surgeon's Manual

historical accumulation of the outstanding pioneers in this field. The last revision of this material was in 1977. Since that time, psychiatric theories, philosophy, and treatment modalities have been refined and redefined. DSM-III was just being introduced in 1977. In July of 1987, DSM-III-R was introduced. A plethora of new psychotropic medications have been introduced. However, the basic functioning and personality style of the aviator remain the same. The stressors inherent to naval aviation remain and disposition challenges are unchanged. In this edition of the U.S. *Naval Flight Surgeon's Manual* an attempt has been made to update time-dependent material, and terminology has been adjusted to correspond to DSM III-R. Additional areas of interest have been added. Exposure to the Naval Aviation environment and its people remain the best teachers of aviation psychiatry.

The Context

A 23-year-old, Lieutenant (jg) naval aviator, flying an F-8 Crusader fighter, is returning to his ship with 20 minutes of fuel remaining. Following instructions from the ship, while making a radar carrier-controlled approach (CCA), he turns four miles astern the ship to make his final approach. His altimeter reads 500 feet when he is informed that the ship's height-finding radar is inoperative, which means they can't tell him how high he is over the water, which he can't see. He's in solid fog and overcast until one mile astern the ship, when he breaks into the clear 300 feet over the water. Now flying at 140 knots, he glances at the "meatball" light on the carrier deck, which tells him that he is about on glide path. The red glare of the oxygen warning light gets his attention for two or three seconds. He asks himself, "Could the gauge be inoperative, the fitting defective; should I simply jerk the mask off? Sure, I don't need oxygen at this altitude. Better check the meatball again -fallen too low - headed directly for the carrier ramp - add full power - too late? No coming up - thank God! - now try to land this beast - missed the first wire - second - third -I've had it! No, caught number four. Full stop. Cut power.

- from *Fear of Flying* by

Captain Roger F. Reinhardt, MC, USN (Ret.)

The Psychology of Flying

"When I strapped that A-4 on, it wasn't the A-4 that was flying, it was me flying up there all over the sky."

That A-4 pilot is saying that flying is really as natural as breathing and fun to boot. His airplane became a part of him. Curiosity and exploration are basic and compelling human drives, and fly-

Aviation Psychiatry

ing is one of the best expressions of them. But people fly, especially in the military, for other reasons, too. Those who fly for “neurotic” or maladaptive reasons are of particular concern to aviation psychiatry.

For those who are naturally drawn to flying, there seems little else in the world as exciting or worth doing. For those who fly for more “neurotic” reasons, it can be thrilling or at least satisfying, but it can also be fraught with anxiety which must be defensively dealt with, either in a healthy, adaptive manner or maladaptively. It takes a bit of the obsessive-compulsive temperament to endure the tedious patrols of a P-3 and a bit of the hysteric to risk life and limb as an F-18 pilot. When, however, these defensive colorings of character become overstressed, they turn maladaptive, and psychopathological responses to flying are encountered.

The Psychopathology of Flying

Psychopathology means the existence of any of the symptoms (uncomfortable feelings) or signs (abnormal behavior) listed in the *Diagnostic and Statistical Manual of the American Psychiatric Association, DSM III-R* of 1988. The psychopathology of aerospace medicine is no different from that found in any other area of living. What is distinguishing is the context in which it arises - the stresses peculiar to military flying. These include: moving in three dimensional space; complex, high performance aircraft; adverse weather; frequent family separations; combat; the one-to-one student-instructor relationship so conducive to transference and countertransference phenomena; the responsibilities of command; and the return to operational flying after long absences occasioned by intermittent staff assignments, schools, or instructor billets.

A few flight students experience problems with space, becoming one with the aircraft, or with the responsibility of solo flight. The most common difficulty in the training period involves the student-instructor relationship. The most common symptoms are airsickness, anxiety, forgetting procedures, gastrointestinal complaints, and depression with its somatic equivalents.

In the professional years, self-esteem is more at stake, with flight anxiety, conversion symptoms, and psychophysiological symptoms the rule. The conversion symptoms usually involve the special senses required to fly, that is eyes, ears, and balance. If psychophysiological symptoms are present, the pilot is usually highly motivated to continue flying, and this can be allowed if health and safety are not threatened. Phobias do occur but are uncommon. When anxiety is present, it is usually expressed as simple fear (anxiety) of flying. In the professional years, one always has to look beyond aviation to search for clues to the pilot's discomfort.

Accident proneness may emerge at any time. It is currently considered to be the result of the character traits of extreme sensitivity to criticism with a penchant for acting out emotional tur-

U.S. Naval Flight Surgeon's Manual

moil. It can also occur as a result of depression, excessive life changes, or of a basic temperament favoring carelessness. The patient may send out warnings in the form of personality changes or minor blunders in various areas of his life.

As the years pass and the pilot becomes a senior aviator, depression or alcoholism are more apt to be encountered. The naval aviator approaching retirement has to be scrutinized closely for the appearance of these symptoms.

The thrill of flying sustains the aviator and the flight officer throughout their careers. It declines through the years, slowly at first, precipitously around thirty, then slowly again. Side by side with the thrill of flying and the fulfillment of belonging to an elite group, there gradually emerges a recognition of the limitations of aircraft, of the dangers, and of family responsibilities, resulting in some realistic, conscious anxiety. The balance of these two - thrill and anxiety, the "love and fear" - determines, at any point, the motivation to continue. The point to be made is that if a young student complains of anxiety or any of its myriad manifestations, something is wrong, and intensive evaluation is indicated. However, if the senior aviator presents similar complaints, it may not necessarily be abnormal. It is normal for him to be aware of some conscious anxiety, and it may not be necessary to ground him. Ventilation of the anxiety and some reasonable discussion to help him weigh his needs and options and arrive at a mature decision may be all that is required.

Pressure from sources other than flying may also arise and interfere with his motivation to continue. Marital adjustment is probably the most common. Captain Frank Dully, MC, USN (Ret.), in his lecture, "Sex and the Naval Aviator," points out that a man's masculinity is at stake both in the cockpit and in his home. If it suffers in one area, the conflict and the feelings may be displaced to and affect the other area. Psychiatric symptoms and impaired flight performance can result. Occasionally, however, flying may be the only conflict-free area and a haven of respite in a troubled life. Because of the close association between the flight surgeon and his men, they may be embarrassed to explore marital problems with him. One flight surgeon found it worked quite well to trade squadrons with his counterpart when it came to treating problems of this sort. A feeling of confidentiality was better preserved, and treatment was more successful.

Combat, with its acute dangers, aggressions, and horrors, may call for the full gamut of defenses. This can range from first line defense mechanisms, such as denial, "It can't happen to me," or to projection, "I'd never pull a stupid stunt like that," through compulsive preflighting, counterphobic daring and carelessness, and somatizations, all the way to an acute psychotic break. The flight surgeon must take the context into consideration, and treatment calls for the time tested principles of proximity, immediacy, and expectancy.

Psychopathology in the Military

Military people are shaped partly by the constraints of the military environment, but they also choose this environment to meet their intrapsychic needs. Most officers and enlisted function proudly and well. Only the legendary five percent create the equally legendary ninety-five percent of the administrative vexation in a command.

Professionals, including pilots and flight surgeons usually have a very adaptive compulsive personality core. If excessively compulsive, over stressed, or if "control" is threatened, the resulting maladaptive behavior may have to be evaluated.

By far the most common source of turmoil and discontent in the younger sailor is the passive-aggressive personality. He comes tailor-made to misfit, engaging in constant battles with authority. He enters the Navy hoping for better and finds worse. An unsuitability discharge is often the only therapy he will accept.

Very dependent people enter the Navy optimistically, but a few cannot tolerate the separation from home or meet the demands for mature, responsible behavior. Few in number, but significant in their ability to create turmoil, are the persons with borderline personality organization and narcissistic personalities. Rarely can these people function effectively in the military environment. They usually are administratively separated either for unsuitability, if they are recognized early enough, or for misconduct if too late. They are unmotivated for military service and, therefore, for therapy, which at best carries a very poor prognosis. The antisocial personality usually creates headaches for both his command and his flight surgeon. Legal or administrative separation is usually indicated.

Occasionally, well-educated or highly intelligent young enlisted personnel become unhappy, bored, resentful, and unable to function. Unfortunately, there is no administrative relief from their particular problem, and they may become mired in disciplinary difficulty for the first time in their lives. They may initially be treated as an adjustment disorder but, if symptoms of maladaptive behavior persist, then a personality disorder may be diagnosed.

There are many real stresses to which the enlisted person is heir. As previously noted, resulting maladaptive behavior may appropriately be labeled as an adjustment disorder (manifested by the presenting symptoms and signs). Pay insufficient to meet the needs of a burgeoning family, moves, separations, combat, moonlighting, and frequent watchstanding are just a few of the stresses. These stresses are usually met at a relatively young age and with few educational, emotional, family, and financial resources. A social worker or family services counselor, if available,

is often better able to handle these real, rather than intrapsychic, stresses than the psychotherapist flight surgeon.

Alcoholism is as serious a problem in the Navy as it is elsewhere. Approximately one individual in ten over the age of 21 will become a problem drinker or alcoholic. It takes about ten years to manifest classical physiological alcohol dependence. About one person in a group of one hundred officers and enlisted personnel will be suffering from it at any one time. Alcohol abuse can produce behaviors in the younger individual as destructive as full blown alcohol dependence (alcoholism). For aviation disposition, there should be no distinction, as a rule, in management of abuse and dependence. DSM-III-R has tremendously "narrowed the gap" in its present diagnostic criteria.

Diagnosis of alcoholic behavior can be difficult. One of the obvious signs of a severe problem is that the patient can no longer control his drinking; he cannot plan or predict where, when, or how he will drink. Another is that his drinking is detrimental to his health, marriage, family life, social life, or occupation, and he cannot modify the behavior. This occurs in spite of counseling (formal or informal) and knowledge of the adverse consequences of his continued maladaptive behavior.

The definition, diagnosis, and detoxification procedures for alcoholism as well as the Navy's rehabilitation program are discussed in detail in Chapter 18, *Alcohol Abuse*. The procedures to be followed when rehabilitation is unsuccessful are outlined in Chapter 15, *Disposition Problem Cases* and utilize NAVMILPERSCOMINST 1910.1 series.

Following rehabilitation, psychotherapy may or may not be indicated. The persistence of psychopathology (symptoms and signs) will be decisive in this regard. The patient should be helped to plan and maintain *his* own program of sobriety. If he is in a flight billet, the flight surgeon must follow the dictates of NAVMEDCOMINST 5300.2 series regarding the procedures for ultimate return to full flight status. OPNAVINST 5350.4 series is an excellent primer on the medical officer's role in drug and alcohol abuse. One has to be careful that proper management is not neglected just because a diagnosis of alcohol abuse and not alcohol dependence is given.

Although the problem of drug abuse is less pervasive, the success of its treatment is more uncertain. Often a serious personality disorder is involved, particularly in the younger person. The treatment for this situation is problematic at best. The Navy's "zero tolerance" policy makes it unlikely that a truly drug-dependant enlisted person will be retained on active duty. For officers and chiefs the chance is nil. Refer to OPNAVINST 5350.4 series and NAVMILPERSCOMINST 1910.1 series for further guidance.

Psychiatric Evaluation

Flight surgeons are faced with assessing, as accurately as possible, the ever shifting balance of natural and “neurotic” motivations for and attractions to flying. This balance is mirrored in the physiological or pathological alterations of personnel who appear as pilots, NFO’s, and aircrew, or applicants and students who apply for and undertake flight training. These conflicts of nature’s laws and human nature’s intrapsychic forces result in maladaptations to flying. The evaluation entails uncovering these contexts in the life of the patient and evaluating his mental and physiological responses to, and ability to cope with, the balance of intra- and extrapsychic forces impinging upon him.

There are two time-honored approaches to the psychiatric interview: The classical approach is to elicit a spontaneous unfolding from the patient of his troubles. This may take extended periods of time. The approach most commonly taught in diagnostic interview techniques today is direct, structured questioning by the psychiatrist preceded by a short interval in which the patient is allowed to “tell his story.”

A thorough evaluation is an artful combination of these two approaches - eliciting spontaneously and tracing the patient’s feelings, and laboriously extracting the dry details of his present and past life. Together, ideally, they should lead to a comprehensible picture of his emotional illness.

Emotional illness almost always occurs in the context of social interaction when core conflict-triggering persons or situations are encountered. These situations very frequently represent major life changes or crises related to the milestones or maturational tasks reflected in the phases of the psychosexual/psychosocial scale of development (e.g., dating, graduating, occupational choice, marriage, parenthood, entrance into the military, return to civilian life, etc.). The need to suppress painful affects, forbidden impulses, or the memory of the original core conflict or fantasized elaborations of it, lead either to defensive symptom formation or defensive, immature behavior. If incapacitation is severe, the symptom formation appears as an Axis I psychiatric illness. The defensive, immature behavior, when persistent and maladaptive, appears as a personality disorder.

For the diagnosis of a personality disorder there should be evidence of maladaptive behaviors, painful affect, forbidden impulse, or core-conflict situations at several points in the past history. This would be reinforced by evidence from the present illness setting and the mental status examination of the psychiatric interview. During psychotherapy, the conflict is unravelled and eventually resolved. The military environment is not suitable for the psychodynamic treatment of personality disorders.

Axis I disorders should meet DSM-III-R criteria, but again may have historical roots and reinforcement in the presentation and mental status examination.

Psychological Testing

A wide variety of psychometric procedures are frequently used in the Navy to augment data obtained through the clinical interview. These instruments are designed to provide objective, standardized, and normative data regarding a wide variety of symptoms, signs, syndromes, and skills. The selection, administration, and interpretation of appropriate procedures requires an active consultative process between the flight surgeon and the clinical psychologist. To the extent that referral questions can be specified, the experienced clinical psychologist may provide a unique contribution to the evaluation of a wide variety of patients. Psychological testing will not be helpful if referral questions are vague; if testing is obtained out of "routine," if the primary care provider requests specific tests, or if the assessment is otherwise treated as if it were a laboratory procedure rather than a professional consultation.

The following information is provided to give the flight surgeon a heuristic appreciation of the more frequently administered procedures.

Emotional Status and Personality

Objective Tests. These include the Minnesota Multiphasic Personality Inventory (MMPI) and Millon Clinical Multi-axial Inventory (MCMI). These self-report, pencil and paper inventories are designed to provide nomothetic, actuarial, information regarding the probability of psychiatric illness. Sophisticated "validity scales" attempt to establish the patient's test-taking attitude and associated desires to either minimize or exaggerate psychiatric symptoms.

Projective Tests. These include the Rorschach, Thematic Apperception Test (TAT), Sentence Completion, and Drawing Techniques. These procedures utilize a wide variety of ambiguous stimuli to obtain ideographic information regarding the form and content of a patient's thought process. Reality testing, perceptual accuracy, interpersonal style, and affective control are also assessed.

Cognition

Intelligence/Aademic Achievemmt. These include the Wechsler Adult Intelligence Scale-Revised (WAIS-R) and the Wide Range Achievement Test - Revised (WRAT-R). Assessment of intellectual skills, to include verbal IQ and performance (visuospatial) IQ, provides an estimate of

the patient's general cognitive ability. Utilization of previously learned information and active problem solving is addressed on individual subtests which use a wide variety of stimulus-response formats. Functional reading, spelling, and arithmetic skills are assessed by standardized tests of academic achievement.

Comprehensive Neuropsychological Assessment. The Benton Tests and the Halstead-Reitan Battery are included. For those patients with known or suspected neurological injury or illness, specific tests of memory, attention and concentration, information processing, executive function, language, and visuospatial skills can assist in the differential diagnosis of neurobehavioral symptoms, monitoring the course of illness, and documenting responses to treatment.

Aviation-Specific Evaluations. Evaluations, interpretation and recommendations may be obtained by the flight surgeon or the clinical psychologist, in consultation with the Psychiatry Department, Naval Aerospace Medical Institute (NAMI) Code 21.

The Psychiatric Report

Any psychiatric evaluation should be thorough, concise, and credible. The format at NAMI was designed with these considerations in mind and has been used successfully for many years. The format is very similar to that used in most military psychiatry training programs.

The art of writing a good psychiatric report is a product of two simple concepts: *Symptoms* occur in a specific *context* to *somebody* who by virtue of an idiosyncratic weakness is unusually vulnerable to that particular context at that particular moment in his life. The meaning of symptoms is discernible only in this context; they have no meaning in and of themselves. The point of departure for exploration is always the symptoms or signs that led to psychiatric referral.

The behavior for which a patient is referred may not always be related to a developmental conflict, and occasionally a patient may be seen with significant conflicts from more than one stage of development. In such cases, the flight surgeon should strive to pinpoint either the conflict that is earliest, or the one which is most prominent in the present illness.

Appendix 6-A presents a detailed outline for psychiatric reports. As a brief review:

1. *Paragraph 1* should contain identifying information and a list or description of the *symptoms* and *signs* that led to the patient's referral.
2. *Paragraph 2* is an outline of the patient's everyday world - where he lives, with whom,

where he works, major illnesses other than psychiatric, and any stressors that impose special burdens on him or others.

3. *Paragraph 3* should describe the *context* in which the symptoms and signs arose, and the precipitating event. If the problem is based on personality functioning, then this context or event, by definition, will be a fresh version of prior conflict-evoking traumas or events reaching far back into the patient's past. The patient may be only vaguely aware of what is upsetting him and will unconsciously attempt to avoid exploring it because of the intense anxiety that it can provoke. It may take very perceptive and tactful questioning to elucidate the actual context. Often it may come to light only through the process of analyzing and removing defenses in the process of psychotherapy.

On the other hand, if the problem is real, rather than the result of personality functioning, the context will be quite apparent and will be such that the average person could be expected to react to it with psychopathology - symptoms and signs. The diagnosis will then be one of adjustment disorder or another Axis I diagnosis such as affective disorder, phobia, or anxiety disorder. Paragraph three should not consist of simply a more exhaustive description of the symptoms and signs (as might be appropriate in general medicine) with no mention of the context. This is one of the most common errors of the nonpsychiatrically oriented examiner. There is no point in reiterating what is already well-known to the referring source while missing the precipitating context and its significance.

4. *Paragraph 4* is a description of the patient, the *somebody*, as revealed by past history from a psychological vantage point. The past history will provide psychosocial information that will support the diagnosis that will be established at the very end of the report. It should outline episodes in the patient's life that will highlight developmental issues such as major stressors, behaviors or risk factors in childhood, adolescence, school, community, and occupation. A family history of risk factors is extremely important. Typically, there will be prior versions of the present problem. Many times a reasonable diagnosis can be based on historical data alone. This can be documented by interview, information on the patient questionnaire, health record review, and information from significant others.
5. *Paragraph 5* is the Mental Status Examination. It should reflect the here and now; it is the most current cross section of the patient's life. It should reflect how he relates to the flight surgeon in the interview and how the flight surgeon thinks he would relate, at that same moment, to significant others in his life outside the interview.

The Mental Status Examination assesses not only the patient's organic intactness but equally, or more importantly from the psychiatric standpoint, his functional or emotional

intactness and potential. The most natural breakdown of mental status is psychological vs. organic functioning. There is one further breakdown to be kept in mind, and that is defenses. Defenses, in this conception, include not only mechanism of defense, but all defenses against anxiety even if some (e.g., the psychophysiological disorders) are somatic expressions of it as well. These breakdowns will help the examiner to organize, in his mind and in his report, myriad possibilities of psychological functioning. The patient's general appearance (this should be the opening item) is added to this and then the description of the psychological functioning is followed with the organic functioning in terms of sensorium (orientation and memory) and intellect. Finally, the patient's judgment, insight, and potential for therapy are discussed. These latter stand out separately because they partake of both psychological and organic functioning and intactness. The results of any psychological tests (Section XXIII) complete the picture of the patient's functioning in the here-and-now, and current moment in his life.

6. *Paragraph 6* is a capsule summary of the patient and his difficulty. It comprises three elements - his personality pattern (be it healthy, or characterologically impaired), the context, and the symptoms and signs. This is the gist of paragraphs one, three, and four. From these and paragraph five, comes the diagnoses in paragraph seven.
7. *Paragraph 7* is written using the multiaxial system. Axis I delineates diagnosed mental disorders and V codes. Axis II identifies personality traits and disorders. Axis III lists any physical illness.
8. *Paragraph 8* contains the recommendations from the military psychiatric standpoint, and these recommendations are in two categories. The first category is administrative disposition physically qualified (PQ)/aeronautically adaptable or adapted (AA)/fit. for duty. The second category is medical which includes the medical care, follow-ups, and referrals.

When structured in this manner, the report strikes the reader with coherence and persuasiveness. One part relates perfectly and logically with another, and the diagnosis falls naturally into place. The patient comes across as a comprehensible human being and the reader will believe what is said and will more likely do what is advised.

The Evaluation of Candidates

Future performance is best predicted by past performance; only failure can be predicted with any acceptable degree of reliability. Therefore, when there is evidence of psychopathology in a candidate which has significantly interfered with his adjustment in the past and which has not

U.S. Naval Plight Surgeon's Manual

been resolved, the flight surgeon may feel secure in rejecting him either on the basis of his maladaptive personality style (lack of aeronautical adaptability), or by actually establishing an Axis I diagnosis. In considering whether to establish a psychiatric diagnosis, however, he should keep in mind that the candidate has not come to be penalized by being tagged with a label that may follow him for the rest of his life. He wants only to fly and seeks an opinion about it. It is often better to give the label of "not aeronautically adapted," with reference to personality style. As will be discussed later, this is of significance only in naval aviation. Persons labeled NAA are usually suitable for routine naval service. If legitimate, adjustment disorder may be a useful diagnosis. This is especially true for enlisted aircrew candidates with multiple life stressors.

The best approach for evaluation is the use of the structured format. The patient's referral symptoms should be looked upon as the chief complaint and his conscious and unconscious reasons for doing so as the context. Although it is nearly impossible to predict success in military aviation, the flight surgeon can look for evidence of early interest in flying, such as building model airplanes, frequenting airfields to watch the planes take off and land, and identification with parents' interest in aviation. Further, there should be evidence of maturing in motivation from the romanticism of the boyhood years to the practical exploration of alternatives of the postadolescent years. Reinhardt (1970) has shown that the outstanding jet naval aviator is an extroverted, first-born, problem solver. He also observed, culminating his remarks on selection, that any normal, red-blooded American boy can learn to fly. Many, however, may lack the basic temperament and motivation for the demands of military flying.

The Evaluation of Students

When students experience problems in learning to fly, the flight surgeon first ascertains the particular aspect of training confronting them and then discerns within it what is stressful for them -the context. Is it the three dimensional aspect of space, a new, more complex aircraft, the idea or feeling of being number one in the plane, of being solely responsible, a real or "neurotic" reaction to the instructor, or perhaps stresses external to flying? From the past history, he must uncover what there is about the student that renders him pathologically susceptible to the particular stress. Is this an overly compulsive student overwhelmed by too rapid a presentation of new material; is this an hysterical individual reacting to unconsciously perceived danger with a conversion symptom or careless, risky flying, or is this a characterologically "normal" student reacting to real and abnormally intense stresses in or out of aviation?

Evaluation of Designated Flight Personnel

The seasoned professional typically may be facing a transition from a staff assignment or school to a new, unfamiliar, more complex, and powerful aircraft, reacting to an incident or acci-

dent, or, just as likely, experiencing problems external to flying. In other words, here the stress is more likely to be real and intense, rather than intrapsychic; the flight surgeon is more likely to be dealing with an adjustment disorder rather than a manifestation of repetitive maladaptive personality functioning. Family stressors, financial difficulties, and potential career changes should be thoroughly explored.

Aeronautical Adaptability

Aeronautical Adaptability - Present Status in the U.S. Military

Navy. All active flight personnel have to be “AA” (Aeronautically Adaptable or Adapted).

On each physical examination of designated aviation personnel, there has to be a finding not only of physical qualification but also of aeronautical adaptability. In addition, all personnel evaluated upon entry into the flight program in the Navy have to have an assessment made of their aeronautical adaptability, in accordance with the Manual of the Medical Department (MANMED), Chapter 15.

Air Force. The Air Force uses a version of the ARMA, even though ratings are applicable only at the time of selection.

Army. The Army has used various versions of the Adaptability Rating for Military Aviation (ARMA) since World War II. Originally, this was a system in which various points are given or deducted for a particular problem. The rating system contained a total of 200 points, and it required 160 points to be considered to have an adequate ARMA rating. The Army is currently using an ARMA that addresses many areas of past and present psychosocial function. The Flight Surgeon makes a judgment assessment and declares either a “satisfactory” or “unsatisfactory” ARMA. This determination can be made at any stage of an Army pilot’s career, but as compared to the Navy usage of AA/NAA, an Army aviator can be reinstated as “satisfactory” under certain conditions.

History of Navy Involvement in Aeronautical Adaptability

Even though the concept of Aeronautical Adaptability has appeared in the literature since 1918, it was only in the late 1920’s that the formal application of aeronautical adaptability appeared in the aviation selection process. At the beginning of World War II, there was no mechanism for disposition of Navy pilots who did not appear adaptable, but instead, they were often labeled as “cowards” or “yellow.” This disposition was indeed unfortunate. The

Psychiatry Department at the old Naval School of Aviation Medicine was tasked with addressing this problem. The term "Not Aeronautically Adaptable" then began to be formally used in the Navy in a non-punitive manner as a reason to disqualify an individual from flying. By design, the definition of aeronautical adaptability was very vague and ill defined. Aeronautical Adaptability continues to be a significant issue both in the Training Command and in the fleet, and is a major problem each flight surgeon faces during his tour. As behavioral medicine becomes more scientifically based, quality assurance becomes more of an issue and credibility has to be maintained. More effort is being expended to qualify, quantify, and make reproducible, the concept of aeronautical adaptability.

Derivation of the Current Usage of Aeronautical Adaptability in Naval Aviation

As of December 1990, the *Manual of the Medical Department*, Chapter 15, states "The examiner shall summarize his impression of the individual's aeronautical adaptability which shall be recorded as 'favorable' or 'unfavorable'. When an individual is found to be physically qualified but his aeronautical adaptability is regarded as 'unfavorable,' the entry of findings on SF-88 as finally recorded shall be 'physically qualified but not aeronautically adapted....' When an individual is found not aeronautically adapted, sufficient comment and information shall be furnished under Remarks or Notes to justify such a conclusion."

Impact of DSM-III and DSM-III-R

1. This manual carefully delineates criteria for each disorder in almost a cookbook approach.
2. Inter-rater reliability for personality diagnoses is probably around 40 to 50 percent. It has been most reliable with the antisocial personality for which there are specific objective criteria. There are no reliable studies on maladaptive personality trait disturbance and the inter-rater reliability varies from study to study.
3. The issue is prediction of behavior. It is known that the patient has a problem but what needs to be known is what effect this will have on his future behavior. The issue is one of predicting behavior in an individual and what criteria we use to make this kind of assessment.

Excerpts from a presentation to the Aeromedical Advisory Committee on 12 August 1987 amplify and clarify the concept of aeronautical adaptability and its relationship to Axis II DSM-III-R personality structure. They conclude that:

"Aeronautical adaptability has long been recognized as one of the most ambiguous concepts in naval aviation medicine. Some recent papers have addressed the topic from various perspectives. Those most often referred to are: "Aeronautical Adaptability" by Cap-

Aviation Psychiatry

tain Patrick F. O'Connell in May, 1981, "Aeronautical Adaptability of Designated Naval Aviators" by Commander John Mangrum in November, 1985, and the NAVAIRPAC *Medical Update Letter*, Volume 12, 5 January 1981, by Captain Frank Dully. From my review, Captain O'Connell's summary reflects the general trend of naval aviation psychiatry thought on the subject."

Aeronautical adaptability as described in MANMED 15.73(l) (Change 100 of August 1986) includes "physical findings and the result of the neuropsychiatric examination." The very fact that the Standard Form 88 requires attention to both physical qualifications and aeronautical adaptability makes it practical and necessary to separate those entities. The logical approach would confine those entities with physical and psychiatric Axis I findings to the physically qualified PQ/not physically qualified NPQ arena. Aeronautical adaptability then would encompass the personality traits and personality functioning of the individual as it pertains to the three dimensional environment of aviation and the individual's functioning as it impacts on aviation safety.

Working Definitions of the Concept

Aeronautically Adaptable (Students and Candidates). "Having the potential to adapt to the rigors of the aviation environment by possessing the temperament, flexibility, and appropriate defense mechanisms necessary to suppress anxiety, maintain a compatible mood, and devote full attention to flight and successful completion of a mission."

Aeronautically Adapted (Designated Aviators and Aircrew). "Those having demonstrated the ability to utilize long term appropriate defense mechanisms and displaying the temperament and personality traits necessary to maintain a compatible mood, suppress anxiety, and devote full attention to flight safety and mission completion." Successful completion of a mission in this context includes not only the safety and crew coordination involved in actual flight but also the ability of the individual to work harmoniously with other squadron members and authority figures. The stresses of operational training and deployment should be easily tolerated. Personal behavior and habits should not impact on his Navy job or flight status.

Helpful Definitions as Defined by DSM-III-R

Mental Disorder. A mental disorder is conceptualized as a clinically significant behavioral or psychological syndrome or pattern that occurs in an individual that is typically associated with either a painful symptom, distress, or impairment in one or more areas of a person's subjective

life. Formal mental disorders are coded on Axis I and are considered to be entities worthy of formal treatment, always with some hope of resolution or stabilization.

V Codes. V codes, even though coded on Axis I, are described as conditions that are a focus of attention, or even treatment, but that are not attributable to a recognized mental disorder. As a general rule, V code diagnoses do not result in significant or prolonged social or occupational malfunction. Unusual psychological distress or discomfort associated with the diagnosis of V codes is usually a component of the individual's style of personality functioning with or without a concomitant diagnosable Axis I or Axis II disorder.

Personality Disorder. Personality disorder is a concept paramount to the understanding of the NAA issue. Personality disorders are considered a repetitive, historically documentable, maladaptive pattern of behavior that is demonstrable in most areas of the subject's life. This impairment is usually most evident in interpersonal relationships. The usual result of an Axis II diagnosis (or disorder) is significant impairment in social and occupational functioning and/or subjective distress. Personality disorders are generally manifest by late adolescence and continue throughout adult life. Personality traits, in contrast, are considered to be one's own individual but enduring pattern of perceiving, relating to, and thinking about the environment and oneself, and are exhibited in a wide range of important social and personal contacts. Personality traits may fluctuate in nature and intensity from situation to situation depending on the individual, and usually are socially and occupationally adaptive. Stress may exacerbate traits to a maladaptive level.

Personality Traits. Personality traits, personality style, and personality disorders as defined are usually identifiable and deeply ingrained in an individual by late adolescence. Personality styles are often exacerbated by stress. The currently accepted biopsychosocial model of personality development does look upon an individual's personality and personality function as being a dynamic concept. Mounting evidence indicates that life experience, repeated stressors, or formal psychotherapy may modify or alter a person's pattern of perceiving and relating to the world. A restructuring of his entire personality style can result. It is the last concept of dynamic transformation that is probably the focus of most confusion and concern about the concept of aeronautical adaptability.

Aeronautical Adaptability as a Durable Quality

It is recognized that persons genuinely not psychologically adaptable to the aerospace environment or who constitute a safety hazard due to their personality traits and inability to suppress anxiety are removed from aviation training programs early on. From this observation comes the concept that aeronautical adaptability as evidenced by earning one's wings is usually considered permanent in a designated naval aviator. All problems thereafter relating to his flight perfor-

Aviation Psychiatry

mance should be of an administrative vice a medical nature. As a general statement, this could be true. The confounding variable is that utilizing the dynamic concept of personality structure, prolonged stressors, significant life events, or psychotherapy can result in a changing of life goals and changing of life philosophy. The revised pattern of personality traits may result in an individual being not aeronautically adapted. Conversely, persons through maturity, learning experience, and behavioral modification over time may go from a condition of not aeronautically adaptable to one of aeronautically adaptable.

Appreciation of subtle but profound change in personality structure after being designated as a naval aviator is probably in the domain of experienced psychiatrists with a broad knowledge of the psychological factors of the aerospace environment and the unique psychological and physical factors of the naval aviation community.

On 12 August 1987, the Aeronautical Advisory Committee endorsed the following concepts:

1. Axis I diagnoses (other than V codes) by definition are considered disorders that warrant treatment and have some hope of resolution and therefore result in an NPQ status for naval aviation. NPQ would be appropriate if the condition were treatable with a high probability of full recovery. After treatment and resolution of symptoms, the patient could be reevaluated with three choices of disposition: (1) permanently NPQ, (2) NPQ with waiver, or (3) PQ if the illness has fully resolved.
2. Axis II diagnoses of a personality disorder would usually result in a designation of NAA. This is with the knowledge that true disorders involve significant difficulty with interpersonal relationships, and acting out or other maladaptive behavior.
3. Personality traits not constituting a disorder manifested by a stress-induced pattern of maladaptive behavior or loss of mature defenses resulting in anxiety, depression, or poor judgment (i.e., loss of suppression) would result in a designation of not aeronautically adaptable if safety of flight, crew coordination, or mission completion were impacted. Unacceptable behavior related to a personality style may itself be reason to administratively remove the individual from the aviation environment.
4. V code diagnoses concurrent with significant occupational or social dysfunction would have to be evaluated in terms of an underlying personality dysfunction (NAA) or true Axis I mental disorder (i.e., adjustment disorder) (NPQ).
5. Axis III disorders would result in a designation of not physically qualified as determined by appropriate authority.

U.S. Naval Flight Surgeon's Manual

With these definitions and concepts in mind, further attention can be given to the utilization of the aeronautically adaptable/not aeronautically adaptable concept. A recommended approach to aeronautical adaptability would be as follows:

1. Once designated, all naval aviation personnel would be considered aeronautically adaptable in spite of performance, motivation, or technical ability. The Field Naval Aviator Evaluation Board (FNAEB) would be the mechanism for handling those administrative difficulties encountered with aviator (a) motivation, (b) performance, (c) attitude, or (d) technical ability. The FNAEB could ask the flight surgeon for opinions on a pilot's PQ/AA status as part of the process. The FNAEB decision could incorporate that opinion.
2. Those aviators presenting with situational stress, anxiety, poor coping, or other problems of a perceived psychological or psychiatric nature would initially be deemed temporarily not physically qualified while appropriate investigations and specialty consultations were made.
3. Aviation personnel who demonstrate anxiety, insidious discomfort with flight, or who have undergone life changes of such a magnitude that personality traits have been modified, might have their aeronautical adaptability questioned. This should initially be investigated by a Local Board of Flight Surgeons. Their background investigations then should be submitted to the Aerospace Physical Qualifications Department, NAMI, Code 42 for review and referral for psychiatric review.
4. The diagnosis of not aeronautically adaptable in a designated aviator with a large time investment in his career has significant consequences. This diagnosis should not be taken lightly and should at the minimum have a NAMI psychiatry review and written concurrence.
5. These criteria should be applicable to naval aviation personnel regardless of geographic location, rate, rank, or designator.

The Manual of the Medical Department, as currently being revised in 1991, addresses the issue of aeronautical adaptability in the following manner

1. Candidates or students must demonstrate reasonable perceptual, cognitive and psychomotor skills on the AQT/FAR (officer candidates only) and must have the potential to adapt to the rigors of aviation by possessing the temperament, flexibility, and mature defense mechanisms to

Aviation Psychiatry

allow for full attention to flight and successful completion of training. The flight surgeon's interview should explore vital areas such as motivation, stress, coping and social adaptability.

2. Once designated, aviation personnel are generally considered aeronautically adapted, based on demonstrated performance, stress coping and use of mature personality defense mechanisms. Personality Disorders or maladaptive personality traits manifested by patterns of chronic maladaptive behavior, emotional instability or impaired judgment would result in a determination of not aeronautically adapted only if safety of flight, crew coordination or mission execution were affected.

3. Apparent loss of aeronautical adaptability in a veteran aviator may be an indication of a serious underlying emotional or physical problem and a complete and thorough evaluation is imperative.

4. When a flight surgeon suspects the loss of aeronautical adaptability in a designated aviator, that individual shall be referred to the Naval Aerospace Medical Institute for evaluation.

5. The Field Naval Aviation Evaluation Board (FNAEB) is the naval mechanism for handling administrative difficulties encountered with aviator performance, motivation, attitude, technical skills, flight safety and mission execution.

6. Unacceptable behavior outside the arena of mission safety and mission execution, whether or not associated with a maladaptive personality style or disorder is administrative in nature and should be managed in accordance with existing directives, e.g. JAGMAN, MILSPERSMAN, and/or pertinent SECNAVINST.

Administrative Psychiatry

Disposition of Evaluation

Ultimate disposition is contingent on the patient's motivation and safety in the aviation environment. A patient suffering from a conversion symptom usually cannot fly safely and must be grounded, at least temporarily until therapy can be used in an attempt to resolve his symptom. One who has a minor psychophysiological disorder, however, may well fly safely, be strongly motivated to continue flying, and may be permitted to do so with or without therapy. In most other cases, symptoms must be resolved before flying can be resumed, and there is good evidence that there is little likelihood of their recurrence. In questionable situations, the patient's case should be brought before a Local or Special Board of Flight Surgeons for disposition.

A Review of Administrative Psychiatry

1. General Principles of Administrative Psychiatry

- a. Psychiatric dispositions should be made in accordance with current selection, retention, and separation criteria.
- b. For general duty, general requirements must be met, usually in accordance with the *Manual of the Medical Department* and if doubt exists, Medical Board and departmental reviews should take place.
- c. For special duty (including aviation), both general and special requirements must be met.

2. When individual behavior violates military regulations, psychiatry may become involved in the disposition.

- a. Psychiatric consultation may be requested for diagnosis, treatment, and disposition of a compensable mental disorder.
- b. Psychiatric consultation may be requested to determine the absence of a compensable mental disorder before a member is processed for administrative separation.
- c. Psychiatric consultation may be requested to facilitate various legal processes.

3. Generally, there are three broad areas of patient disposition.

- a. *Medical* - a person has a medical condition which renders him unsuitable to continue to perform duties effectively or safely.
- b. *Administrative* - a person has a pattern of behavior or other unusual circumstance that is a burden to the Navy.
- c. *Special Duty* - To clarify physical or psychiatric suitability for special assignments, such as aviation, or to continue in a special designation.

Administrative Disposition

1. Performance and conduct are key factors influencing administrative separation decisions.

2. Individuals must be counseled and provided with an opportunity to correct deficiencies prior to the initiation of administrative separations in the areas where performance or conduct form the basis for separation, as documented in the member's record. NAV-MILPERSCOMINST 1910.1 series currently governs administrative discharges.
 - a. It requires the commands to expend every effort, via counseling, education, and discipline, to salvage an individual whose performance may be defective.

 - b. Administrative dispositions should be pursued when a command has exhausted resources mentioned above, and the individual becomes a burden and drain on the command resources.

 - c. Commands are instructed to use rapid compliance with the processing of administrative separations only after all legal charges have been resolved.

 - d. If an individual has served six years, he or she has a right to an Administrative Field Board, at which he or she may be represented by counsel in his or her own defense as a part of the separation process.

 - e. Some formal reasons for administrative separation are listed below:
 - (1) Expiration of service obligation.

 - (2) Selected changes in service obligation.

 - (3) Convenience of the government.

 - (4) Defective enlistment - MILPERSMAN 3620280.

 - (5) Fraudulent enlistment - MILPERSMAN 3630100.

 - (6) Entry-level performance or conduct - MILPERSMAN 3630200.

U.S. Naval Flight Surgeon's Manual

- (7) Unsatisfactory performance - MILPERSMAN 3630300.
- (8) Homosexuality - MILPERSMAN 3630400.
- (9) Drug abuse rehabilitation failure - MILPERSMAN 3630500.
- (10) Alcohol abuse rehabilitation failure - MILPERSMAN 3630550.
- (11) Misconduct - MILPERSMAN 3630600.
- (12) Separation in lieu of trial by court martial.
- (13) Security.
- (14) Unsatisfactory participation in Ready Reserve.
- (15) Separation in the best interest of the service.

3. Convenience of the Government specifically includes (MILPERSCOMINST 1910.1 series):

- a. Personality disorder.
- b. Parenthood.
- c. Obesity.

4. Confusion often arises over the reasons for discharge versus the type of discharge. The five types of discharge are:

- a. Honorable discharge.
- b. General discharge.
- c. Discharge under conditions other than honorable.
- d. Bad conduct discharge (must be at the direction of a court martial).
- e. Dishonorable discharge (must also be at the direction of a court martial).

Aviation Psychiatry

Aviation Disposition (Special Duty)

1. An individual unfit for military service is also not physically qualified for aviation, but one may be not physically qualified for aviation and physically qualified for general military service.
2. Therefore, to qualify for aviation duty, one must be fit for full duty.
3. Medical Boards and Special Duty - The function of the Medical Board in this situation is to return the patient to full or limited duty, if warranted. If the Medical Board (or consultant) decides that the patient is fit for full duty, they should so state. The question of special duty must be separately addressed by those who have received special training. In the case of aeronautically designated personnel, MANMED 15-67 places the responsibility for flight status determination on the shoulders of the flight surgeon. If the patient is placed on limited duty, even the patient's flight surgeon cannot return the patient to flight status.
4. Local Board of Flight Surgeons - described in MANMED, Chapter 15. Usually convened by the squadron commanding officer.
5. Special Board of Flight Surgeons - described in MANMED, Chapter 15. Convening authority is the Commanding Officer of NAMI.

Medical Disposition Via Medical Board - MANMED, Chapter 18 - 7/32

1. Nine reasons for Medical Boards:
 - a. Physical defect which precludes military service.
 - b. Military service will aggravate an existing physical problem.
 - c. Long hospitalization or intense medical supervision is required.
 - d. Condition is temporarily incompatible with unrestricted duty but full recovery is anticipated.
 - e. Ultimate recovery is uncertain, and a period of evaluation is desirable.
 - f. Condition requires geographic or other limitations of assignment.

U.S. Naval Flight Surgeon's Manual

- g. Mental competency is in question.
 - h. Patient refuses indicated treatment.
 - i. A condition likely to recur needs to be formally documented.
2. Three Medical Board recommendations are possible:
- a. Fit for full duty.
 - b. Fit for limited duty.
 - c. Referral to the Physical Evaluation Board (PEB), usually via NAVMEDCOM departmental review.
3. The Central Physical Evaluation Board determines:
- a. EPTE vs. DNEPTE (Existence prior to entry).
 - b. Line of duty vs. misconduct.
 - c. Disabling compensable disorder.
 - d. Disability rating.
4. Temporary Duty Retired List, (TDRL) - TDRL's are usually reevaluated by the specialty clinic. Personnel may be found permanently disabled after five years of TDRL.
5. Appeals - Everyone who receives a medical board should be encouraged to submit a rebuttal at all levels if legitimate and sufficient cause exists.

Treatment Modalities

Brief Psychotherapy

Everyone carries recorded in his mind affectively colored experiences and fantasies that shape his map of reality (and behavior) and may lead him to misperceive his present situation and to respond inappropriately. Painful feelings and symptoms may be the result. The therapist attempts

to help the patient recover these latent memories and fantasies with their associated feelings so that he can reassess and interpret accurately what is going on in the here and now, relinquish symptoms and painful feelings, make realistic decisions, and take appropriate action. In earlier teachings these feelings were termed "neurotic." Now using DSM III-R terminology they usually fall in the realm of Axis II - personality styles, traits, or disorders. An Axis I diagnosis may also be present.

Brief psychotherapy is crisis and present-problem oriented. In its effort to relieve painful feelings, it delves only into that aspect of the past that directly pertains to the presenting problem. It takes advantage of the fact that the patient's greatest motivation for change occurs in times of crisis and that the solution of one problem may lead to beneficial alterations in the total personality with considerable maturation of the individual. It is a mixture of techniques from as simple and practical as providing a good night's sleep to as esoteric as dealing with transference. The crucial element in brief psychotherapy, however, is the working or therapeutic alliance - one adult working with another within the mature aspects of their personalities to help the patient shed pathological defenses or maladaptive behavior and resume responsibility for his life and future. A balance is struck between a purely supportive approach and the superficial uncovering of counseling vice a purely psychodynamically oriented mode of therapy.

Since identification with the therapist is fostered or at least not discouraged as one means of maturing and improving defenses, it follows that the therapist must be a model of incorruptibility. Further, he should be the vehicle for "corrective emotional experiences" with responses different from the presumed pathological ones of the patient's parents or parental surrogates or others in his past life who may have reinforced maladaptive behavior.

In brief psychotherapy, the number of sessions is set from the beginning. Usually ten to twenty sessions are adequate to promote the exploration of dependency, conflicts, and separation anxieties. Separation and fear of abandonment are common problems of our age, particularly exacerbated in the military environment and by the solitary nature of some aspects of military flying.

The Technique of Brief Psychotherapy.

1. The therapist is much more active than in traditional psychotherapy, and therapy is face to face.
2. The diagnostic process as described in the section on psychiatric evaluation is undertaken with assessment of personal strengths, defense mechanisms, and suicidal or homicidal risk.

U.S. Naval Flight Surgeon's Manual

3. The focus is on the main conflict in the here and now. The context of the symptoms, the current life crisis, the emotionally hazardous situation, and the patient's perception of the feared stimulus are explored (Mitchell, 1976).
4. The working alliance is actively fostered via appealing to the rational person, encouraging positive transference, and instilling the feeling of hope.
5. Negative transference is promptly interpreted.
6. Time limits are set early in the therapy to promote an active working alliance and to set the stage decisively for the activation and exploration of dependency conflicts and separation anxieties.

Some Principal Elements of Treatment.

1. The reduction of anxiety by:
 - a. The showing of interest and respect for the patient's worth as a human being and by taking a careful history.
 - b. Medication and rest (may even include brief hospitalization).
 - c. If referral or hospitalization is indicated, the therapist should explain thoroughly what the patient can expect on admission and be prepared to deal with the anger or rejection. Talk of more lengthy treatment should be deferred until the therapist has accomplished what he can do, otherwise, his efforts will come to a screeching halt the moment the patient realizes that his therapist is going to refer him to someone or somewhere else.
2. Ventilation - This implies listening on the part of the therapist. The patient voluntarily exposes himself mentally to what he fears as he ventilates. This is a form of self-desensitization to the feared stimulus and is ameliorative, if not curative. The degree to which the patient ventilates varies directly with his confidence and trust in the therapist's acceptance.
3. Reality testing - This is indicated if the patient is anxious, depressed, or confused. Methods are:

Aviation Psychiatry

- a. Defining the problem - context of symptoms - such as:
 - (1) Lack of fusion with the aircraft.
 - (2) Being in control.
 - (3) Student-instructor relationship.
 - (4) Problems external to flying.
 - b. Reviewing goals - reminding the patient why he chose to fly.
 - c. Reminding the patient that a modicum of anxiety is normal under his circumstances, and that he is like everyone else.
4. Emphasis of assets, especially the ability to solve the newly-defined problem. Initiative is given to the patient.
 5. The clear definition of the presenting problem. Goals for the therapy relative to the presenting problem are set.
 6. Wherever possible, the elicitation from the patient of a firm contract for a *specific* behavioral change, a change highly desired by the patient. This has the added advantage of simultaneously bringing his defenses and inhibitions into the sharpest possible focus for therapeutic scrutiny and resolution.
 7. Agreement between the patient and therapist on what the signs will be that the contract has been fulfilled, so that they will clearly know when that takes place.
 8. Repair of feelings of low self-esteem via identification with the therapist and using him as a role model.
 9. Loosening of rigid or pathological defenses. This is fostered by confrontation and interpretation.
 10. Encouragement and strengthening of healthy defense mechanisms.
 11. Encouragement of the patient to meet his responsibilities and, where possible, to face what he fears in manageable increments.

U.S. Naval Flight Surgeon's Manual

12. Emphasis on his success, no matter how small, for positive feedback.
13. Interpretation of genetic or psychosocial determinants or risk factors. This means exploration of the patient's past, but only as it relates to the present problem and only as the patient is able to tolerate the feelings.
14. Occurrence of insights with opportunities for the patient to change, redecide old issues, relinquish archaic ties, make new decisions, and take initiatives. Interpretation and insight are therapist and patient forms of graduated, feared-stimulus exposure and desensitization in psychotherapeutic terms that lead to amelioration or cure.
15. Environmental manipulation. This can range from a night's rest, rescheduling a flight, or changing instructors, to the extreme of hospitalization. Manipulation is to be used sparingly because it is infantilizing. It is better to encourage him to make necessary changes himself. A permanent change of station (PCS) can usually be recommended only in the context of a Medical Board, and only as part of a therapeutic plan.
16. Finally, termination as agreed upon, or earlier, if the patient is able to take over and solve his problem. The termination interview should include interpretation of any anger at rejection and an open invitation to return.

Three Phases of Therapy.

1. *The Opening Phase.* The patient attempts to develop trust in the therapist, and for a time, becomes symptom-free as he finds someone in whom he can gratify his infantile needs. This can lead a therapist to conclude that he has accomplished a miraculously speedy cure.
2. *The Middle Phase* Symptoms return and work begins.
3. *The Closing Phase.* Dependency, conflicts and separation anxieties exacerbate as the patient realizes that termination is imminent. Symptoms may temporarily erupt again as a defense against having to leave the therapist. There may also be an unconscious anger at being rejected, and the defense and anger must be identified and interpreted.

Other Important Concepts.

1. Countertransference - the often irrational and infantile feelings generated in the therapist by the patient that come from the unresolved conflicts in the therapist's past. These can be used to

advantage or can be detrimental to the therapy. This phenomenon can alert the therapist to the fact that the patient is dealing with neurotic conflicts and feelings. The patient may try to “hook” the therapist, so to speak, into neurotic interaction to gratify infantile needs. The therapist may succumb wittingly or otherwise, and the therapy will be sabotaged. If the therapist finds himself unable to resist the latter outcome, the patient must be referred to someone else. Few therapists can deal with all types of patients, particularly without psychotherapy themselves to remove as many of their blindspots as possible.

2. Note-taking during sessions may be appropriate if used sparingly for the initial evaluation, but in therapy it is to be avoided. After the therapy session is over, the therapist may find it helpful to reduce his thoughts to the format of the SOAP formula of the PROMIS system. The themes of the hour can be summarized under “Subjective.” Any changes in the mental status (a sort of mini-mental status), for example, alterations in defenses or development of insight, can be recorded under “Objective,” as well as any laboratory findings, current tests, additional outside information, or the results of consultations with other specialists. Thoughts about what is going on, or a major shift in diagnosis can be briefly put down under “Assessment.” Recommendations and follow-up for the next hour will come under “Plan”. This method will keep the therapist from straying, wandering, and wasting precious time, a thing all too easy to do in such a potentially nebulous undertaking as psychotherapy.

Marital Therapy - A Brief Summary

Marital therapy is not individual therapy with two people; there are unique, complex dynamics involved in the marital relationship that extend beyond the boundaries of the marital partners. However complex this relationship, it is still possible to unravel and understand enough of it to effect a change in a disturbed marriage. The responsibility for change rests with the husband and wife, whether it be to make the change within the marriage or to change by separation. There even may be the decision not to change but to keep the status quo as the least painful of the three choices. Any one of the three decisions - stay married and change, divorce, or make no change - is legitimate, but it should be made on the basis of information derived from the marital therapy process.

The marital therapy process is based on two concepts germane to any interpersonal relationship - needs and communication. If needs complementary to the marriage, conscious or unconscious, are met, then the relationship remains stable. If these needs are not met, then communication is necessary to establish an awareness and a means whereby they will be met. It is helpful to have the couple enumerate their needs both as individuals and as partners in a marriage. This serves two purposes: one, to bring into mutual awareness the expectations each holds for himself and the

partner which then can develop into a mutually shared experience that underlies every successful marriage, and two, to introduce fundamental communication usually lacking in problem marriages. Communication is not limited to mere verbal exchange, but it includes connotation and nonverbal cues as well.

The flight surgeon will probably not have time to do long-term marital therapy; what he can offer will be short-term, supportive counseling. Referral sources such as Family Services, chaplains, local ministers, other medical and psychological specialists, and even books on the subject are invaluable in extending his limitations for comprehensive treatment. If long-term therapy is indicated, the flight surgeon should have available a list of appropriate referral sources that includes payment modality and personal knowledge of qualifications.

Because of the frequent absence of the spouse due to deployments and unaccompanied-tour duty stations, the effectiveness of marital therapy may be compromised. Supportive therapy and use of referral sources become essential in treating only one partner. For the husband, the flight surgeon may be limited to treating the symptoms, depression, anxiety, etc., and simply being available as someone for him to talk to. For the wife, the flight surgeon will be limited to his list of referral sources and making appropriate recommendations. The kinds of problems encountered may range from newlyweds' initial adjustment arguments to complex sexual dysfunction involving other psychiatric problems extending to the entire family.

The flight surgeon's goals and values underlying marital therapy should allow for divorce or separation as a realistic "treatment" alternative and prepare him to assist in that task. If divorce is the result of therapy, the goal should then be to return each partner to a functional status.

Behavior Therapy

Theories of Behavior Therapy. All behavior therapies rest on the assumption that most human behavior, normal and abnormal, is learned. As such, behavior treatment involves the application of learning principles to modify or eliminate maladaptive behavior and to acquire behaviors considered to be adaptive.

1. *Respondent (Classical) Conditioning.* If a neutral stimulus becomes temporarily associated with another stimulus which naturally evokes an unlearned response (reflex), and the two are paired repeatedly, the neutral stimulus alone will then evoke the unlearned response (reflex). The formerly neutral stimulus has now become a conditioned stimulus and the reflex a conditioned response. This principle is applied in a wide variety of behavioral treatment techniques such as aversive conditioning and systematic desen-

sitization. This concept is frequently used in working with symptoms of performance anxiety and motion sickness.

2. *Operant Conditioning.* When a response is made to a given stimulus (which results in something happening) that increases the probability that the stimulus-response connection will be made again (reinforcing), operant conditioning has taken place. This learning principle finds application in the treatment of many psychopathological conditions ranging from schizophrenia to conduct disorders in children, and it is also employed in assertiveness training.
3. *Social Learning.* Repeated animal and human studies demonstrated that subjects could learn quite complex behaviors simply by seeing and hearing other subjects model these behaviors. There are many variables that influence learning through modeling, such as the observer's sex and age in relation to the model. Group therapies, including Alcoholics Anonymous, play therapy, and marital therapy, are some settings in which social learning principles are used in behavioral treatment.

Techniques of Behavior Therapy: Relaxation Therapy, Biofeedback, and Systematic Desensitization. Anxiety related to specific situations is effectively treated via relaxation with desensitization. Relaxation therapy or biofeedback can be very effective in treating anxiety symptoms in which no specific context can be identified. Respondent conditioning principles apply in these techniques.

1. *Relaxation Therapy.* The following procedure is used in teaching the patient relaxation "exercises:"

- a. Sit or lie comfortably in a chair or sofa in a quiet, semi-darkened room.
- b. Tense and relax individual muscle groups (forehead, face, neck, shoulders, arms, back, stomach, thighs, calves). Tense each muscle group for about three seconds before relaxing and going on to the next.
- c. Focus and concentrate on rhythmic breathing, deeper muscle relaxation, and the imagination of a pleasant, relaxing experience.
- d. Lie totally relaxed for approximately one minute, then awaken by counting backwards from five to one.

This procedure, elaborated upon in various text books, is practiced by the patient twice a day for approximately a week, or until he is able to relax himself at will using the technique. Commercial audio and video tapes are available.

2. *Systematic Desensitization.* The application of relaxation in systematic desensitization begins with the patient constructing an "anxiety hierarchy," a graded list of situations or events which evoke anxiety. The patient then imagines each item on the hierarchy while in a deeply relaxed state. In particularly difficult cases, drug relaxants or hypnotics may be used in conjunction with the relaxation procedure described above. The patient progresses from least to most anxiety-arousing events as each evokes absolutely no anxiety when vividly imagined by the patient. In-vivo desensitization is also practiced by the patient, if practicable (e.g., sitting in the cockpit of an aircraft for flight anxiety).

3. *Biofeedback.* Biofeedback utilizes the same techniques plus electronic monitoring of the tension of specific muscle groups. This allows the patient more control and provides instant awareness of progress.

Other Techniques. Modeling and role-playing are general methods of behavior therapy which simply involve the interaction of patient and therapist and the patient and important others as models for desired behavior acquisition. The selected behavior is observed, then practiced, until skill is attained and anxiety is absent. Assertiveness training, fixed-role therapy, and a wide variety of group and play therapies employ modeling and role-playing. This form of therapy is usually utilized only in specialized situations and by therapists specially trained in the methods.

Aversive Conditioning. Aversive conditioning is used in the treatment of alcoholism by developing an aversion towards alcohol through the ingestion of Antabuse. Narcotic and tobacco addiction are treated in the same manner but by different drugs as the aversive stimulus.

Chemotherapy

General Considerations. More and more of the organic substrate of emotional illness is being discovered. This does not mean, however, that the psychological factors can be discarded. They must both be dealt with, or the patient will remain partially crippled. He may be so confused, upset, or depressed that he cannot think about his problems until some physical or chemical stability is restored. On the other hand, to restore him chemically and ignore his interpersonal problems is to invite their recurrence. Specific chemotherapies will be elaborated upon later in the text.

Aviation Psychiatry

Patient Personality and the Placebo Effect. A significant portion of the effect of any medication is a function of the physician's relationship with the patient and the phenomena of transference and countertransference. On the negative side, the patient may have an unconscious need to defeat the therapist by being noncompliant. As a matter of fact, to recover may mean facing some anxiety, giving up a secondary gain, or both. If the medication fails to work and produces unpleasant side effects in the bargain, damaging effect on rapport and morale are a likely outcome. Patients should be given verbal and written explanations of the usual side effects of any psychotropic medications.

It is often useful to take into account the personality and traits of the patient when prescribing psychotropics. Elaborate detail, perhaps even a minor ritual, may be helpful for the obsessive-compulsive patient; conversely, a minimum of detail, leaving as much control to the patient as possible, may be appropriate for the passive-aggressive, and firm insistence may be indicated in dealing with the patient who must deny dependency and who, for that reason, normally shies away from all medication.

Hazards of Drug Therapy in Psychiatric Treatment. One must think twice before prescribing medication for the alcoholic, the compulsive overeater, or the overtly dependent patient. In a depressed patient, suicidal risk must be balanced against the need for trust in a therapeutic relationship. If the patient departs from the regimen prescribed (for defensive reasons), gentle confrontation and interpretation are indicated. Physiological side effects may be sufficient to result in increased, rather than decreased, anxiety and may be misinterpreted by the physician, leading him to overprescribe or add other medication, compounding the problem and seriously eroding trust.

Lastly, the therapist must avoid using drugs as a substitute for psychotherapy rather than as an adjunct. In dynamic psychotherapy, the use of medication tends to focus the patient's attention on reality issues and away from unconscious factors and feelings. As a general rule prescribe no more than a week's supply of medication at a time for suicidal risk patients. Monitoring of side effects and serum levels will give other confirmatory information that the patient is not hoarding medication for suicidal purposes.

Psychoses

Psychotic or bizarre behavior in an active duty member not only tends to create turmoil in an operational unit but also tends to tax the abilities of the flight surgeon. Psychotic behavior can occur in any age, rate, or rank. In the military environment, medical disorders and intoxication always have to be considered. Schizophrenia is the prototype for psychotic behavior. One of the

popular, but not confirmed, current organic explanations of schizophrenia is that an excess of dopamine is produced by a deficit of dopamine B-hydroxylase, the enzyme that normally converts dopamine to norepinephrine in noradrenergic neurons. This may also explain the depression and apathy that often accompany the disturbance of thought processes. It is of interest to note that alcohol consumption leads to an increased synthesis of these same catecholamines, leading to the possibility of aggravating schizophrenia. This process might also explain why alcohol might relieve depression temporarily. Other studies suggest that Antabuse inhibits dopamine B-hydroxylase, thereby mimicking or aggravating schizophrenia and producing the occasional Antabuse psychosis.

Antipsychotic drugs (e.g., the three major groups - phenothiazines, butyrophenones, and thioxanthenes) have many properties, but they all share one, the ability to block dopamine receptors. This same property is responsible for two other effects, extrapyramidal symptoms and tardive dyskinesia. Fortunately, the anticholinergic drugs, such as Bientropine (Cogentin) can partially overcome this by readjusting the balance between acetylcholine and dopamine. Those phenothiazines with the most prominent anticholinergic properties (e.g., Mellaril) are least likely to produce extrapyramidal symptoms. Unfortunately, there is no "best" treatment for tardive dyskinesia. An unconfirmed popular irony of tardive dyskinesia is thought to be the result of a progressive hypersensitivity of the blocked dopamine receptors to the presence of even small amounts of dopamine.

Neuroleptic malignant syndrome is an entity characterized by hyperthermia, tachycardia, tachypnea, increased WBC and CPK. It is life threatening. Neuroleptics should be discontinued and standard medical textbooks should be consulted for current treatment modalities. Lorazepam may be an alternative drug if psychotic symptoms persist.

The antipsychotics are the treatment of choice for psychotic behavior, even that of toxic or infectious etiology. It is wise to become well-acquainted with two members of this class of drugs. A sedative drug and a high potency drug are recommended. The sedative effect is immediate. The antipsychotic effect is cumulative and may be delayed from hours to days. Therefore, once the patient is under control, the total daily dose may be given at bedtime to take advantage of the sedative effect at night and not hinder the patient during the day. Suggested medications to become familiar with would be Thorazine for the sedating type and Haloperidol (Haldol) or Fluphenazine (prolixin) for the nonsedative high potency type. Recent literature suggests concomitant administration of lorazepam (Ativan) may be helpful, especially in severely agitated patients. Haldol in a dose of 2 to 5 mg p.o. or IM every 30 to 60 minutes until calm is usually adequate for most psychoses. On occasion, restraints may be necessary until the patient calms. If hypotension occurs and threatens the patient, Levophed or Neosynephrine may be given, but

epinephrine-like compounds may potentiate the hypotension because phenothiazines are A-adrenergic blockers.

If extrapyramidal symptoms incapacitate the patient, Benztropine (Cogentin) 1 mg, may be given I.V. or I.M. STAT and then p.o. from 1/4 to 1 mg b.i.d. Diphenhydramine (Benadryl), 25 to 50 mgm, I.V., is a reasonable alternative and preferred by some. Anticholinergic excess in its own right can produce psychotic symptoms. Therefore, the least amount necessary should be used, and the patient should be titrated off of them when possible. It may be sufficient from the outset simply to lower the antipsychotic medication. Severe extrapyramidal symptoms could be life threatening if not treated.

All patients exhibiting psychotic behavior should be stabilized and referred to the nearest medical treatment facility. Psychotic behavior is always NPQ for aviation. As a general rule, such cases should be referred to a medical board to determine suitability for general duty. Recidivism and complicated management make further active duty unlikely.

Mood Disorders

Mood disorders, including major depression and dysthymia, are not uncommon presentations in the operational environment. Proper intervention and treatment may allow later return to aviation duty by waiver. Bipolar disorder usually presents in a very dramatic fashion. Management is often difficult and such cases are permanently disqualified for aviation duty.

Mood disorders are thought to be a result of a change in the functional availability of neurotransmitter catecholamines, including norepinephrine. The norepinephrine level may be increased, but symptoms will not manifest themselves unless the serotonin level is low. Serotonin deficiency seems to be associated with insomnia; acetylcholine increase or norepinephrine decrease is associated with psychomotor retardation. If norepinephrine or other catecholamines are in excess, agitation is produced.

Antidepressants, now often called heterocyclics, are the drugs of choice for depression, as they act to increase the catecholamines and serotonin by blocking their reuptake, and they have some anticholinergic effect. The dosage may vary somewhat according to specific type. The rule of thumb is to start low and go high. The most common error is undertreatment. The single biggest cause of refractoriness to antidepressant treatment is inadequate dosage. Dose equivalents should be between 150 and 300 mg of imipramine for four weeks before considering alternative medication or supplementary medication. Desipramine, imipramine, and trazodone are commonly used in the military. Amitriptyline and other sedating, heavily anticholinergic medications usually have such serious side effects that they are not practical for outpatient use.

Fluoxetine (Prozac) is a new serotonergic antidepressant that has a minimum of side effects and offers promise. Most experts feel the therapeutic benefit is the same for all of the antidepressants. The physician should try to utilize one with the fewest side effects. The sedative effect, as with the antipsychotics, is immediate. The antidepressant effect is cumulative and delayed. For this reason, all the medication may be given at bedtime to take advantage of the sedative effect. Before declaring a treatment failure, the medication should be continued for at least three weeks, all the time striving for a therapeutic dose. Improvement will often take that long to become evident. The risk of suicide rises as the patient becomes more energetic; he must be observed closely until improvement is sustained and he resumes functioning. In severe cases of depression, electro-shock therapy may be resorted to as an emergency measure against the danger of suicide. Remission of the illness is evident when the patient begins eating and sleeping normally, and his energy seems restored. The antidepressant dosage should be maintained for a minimum of six months. After six months, if the patient is completely symptom free then the medication should be tapered off completely over a three-week period. If symptoms return, then twelve months of maintenance dosage is in order. Authors agree that the more intractable the initial symptoms, the longer the maintenance period must be.

As a general rule, all military patients being treated with antidepressants should be on a limited duty board. After a single episode of major depression, and in full remission, a member, when returned to full duty, is NPQ for aviation but may warrant a waiver for return to aviation. Patients with recurrent depressions are permanently NPQ and should be referred for a medical board to determine fitness of general duty.

Bipolar disorder is theorized to be due to an excess of norepinephrine or other neurotransmitters. Bipolar illness usually responds very well to lithium, but it takes several days, four or more, for an effective blood level to be reached. In the interim, Haldol or Thorazine are the drugs of choice, with 2 to 5 mg of Haldol or 50 to 100 mg of Thorazine I.M., a starting doses. They may be given every 30 to 60 minutes until the patient is calm.

Lithium is thought to act by accelerating the catabolism of norepinephrine, inhibiting the release of norepinephrine and serotonin, and stimulating the norepinephrine reuptake process. Further, it appears to stabilize intracellular sodium (thought to be increased in depressions) via the sodium-potassium-adenosine triphosphatase system, which is also magnesium dependent, and is possibly involved in corticosteroid stabilization. More lithium is required in the early agitated phase, as much as 1500 to 2000 mg per day, but the requirement quickly falls with the patient's improvement to about 600 to 1200 mg per day for a blood level that ranges from 0.8 to 1.5 mEq/L. Hydration must be carefully maintained. Any febrile illness with diaphoresis or loss of fluid through diarrhea may result in toxicity, which will occur rapidly above 1.5 mEq/L, and death

Aviation Psychiatry

may supervene at 3.0 mEq/L. Signs and symptoms are those of the central nervous, gastrointestinal, and cardiac systems. Lithium must be promptly discontinued until proper hydration is regained; the level will fall quickly. Lithium cannot safely be prescribed without the ready availability of a competent laboratory. Those with illnesses requiring lithium are always NPQ for aviation. Due to the hazards associated with lithium, its use in any operational setting should be discouraged, and in general, the patient should be referred to a Medical Board.

Anxiety Disorders

The physiology of anxiety is just beginning to be unraveled. The GABA (gamma aminobutyric acid) system of the brain, with its suggested benzodiazepine receptor system, is proving to be a fruitful area of research. Most commonly used anxiolytics are in the benzodiazepine family and all have a high potential for physiological dependence. Anxiolytics should only be considered short-term adjuncts to other forms of therapy in cases of situational anxiety. In those cases where a more severe diagnosis exists, long term therapy may be necessary to maintain function. The safety of long-term benzodiazepine use continues to be documented. Therapy should not be withheld if justified by the diagnosis.

Panic disorder should be considered in anyone with recurrent "anxiety" accompanied by autonomic symptoms. Generalized anxiety disorder and post-traumatic stress disorder are occasionally encountered in the active duty population. Obsessive compulsive disorder is less frequently encountered. Individuals with these disorders are considered NPQ for aviation, and usually unsuitable for general duty. Treatment should be rendered under the auspices of a Limited Duty Medical Board. A waiver for return to aviation duty might be considered after the patient has been symptom free for one year.

Xanax (alprazolam), appears to be the drug of choice for uncomplicated anxiety and panic attacks. Its initial sedative effect rapidly disappears in most cases. The effective dose ranges from 0.25 mg. Q.I.D. to 2 mg. Q.I.D. in some cases of panic disorder. On higher doses and longer periods of time, physical withdrawal must be considered. Always taper the dose. A good rule is to taper by 0.5 mg per week.

Buspirone (Buspar), a noncontrolled anxiolytic, is now available for anxiety disorders. Reports on its usefulness are conflicting. In using anxiolytics, as with all psychotropics, the sedative side effects must be stressed. Patients should be cautioned against the concomitant use of alcohol.

Sleep and Insomnia

Insomnia is an ubiquitous complaint, especially in psychiatric patients. Rather than automatically prescribing a sedative, however, the physician should investigate for the many causes of insomnia and, where possible, treat the basic cause. Situational anxiety is probably the most common cause of insomnia, followed by depression. Antidepressants rather than sedatives may be the treatment of choice. If a sedative is appropriate, however, a short-acting benzodiazepine is the drug of choice such as Triazolam (Halcion) in doses of 0.125 to .5 mg p.o. HS. The short half-life reduces the chance of hangover. Some reports suggest retrograde amnesia when taken in conjunction with alcohol. Even though useful, it seems wise not to prescribe benzodiazepines for more than a few nights, while attacking the basic problem through other avenues. Benadryl 50 mg p.o. HS can be a useful, nonaddicting sedative to use. Recent studies also have suggested the usefulness of L-tryptophan in doses up to one to two grams at bedtime. The use of sedatives to assist sleep in sustained operations is a continuing debate. The British use of Halcion in the Falklands war increased interest and also demonstrated effectiveness when used under proper conditions.

Psychiatric Emergencies and Suicide Prevention

True psychiatric emergencies are those that require the extreme of intervention in a patient's life - providing him with prosthetic controls, either, chemical or structural, usually accompanied by hospitalization. This provides him with additional control over his impulses when his controls are insufficient for his or others' safety. The situations that meet these criteria are those of confusion, psychosis, and impending suicide or homicide. Another way to define this is defining the patient as gravely disabled or a threat to himself or others. In the military, administrative situations may dictate admissions.

Confusion, as an emergency, means that the patient is unable to manage his life. In treating it, the physician must distinguish between organic and functional causes and treat accordingly. Helpful in this regard is a history from a reliable informant and the signs that are characteristic of CNS involvement - disturbance of orientation, memory, intellect, affect, and judgment, and visual hallucinations. Auditory hallucinations are more typical of the functional illnesses. In any psychiatric emergency, a complete medical evaluation is indicated.

Other emergency presentations and management have been discussed in the sections on treatment modalities, psychoses, mood disorders, anxiety disorders, and drug overdose.

The danger of suicide generally presents as ideation, gesture, or attempt. When ideation

Aviation Psychiatry

presents, estimating the danger of it being translated into action is difficult. All attempts at self-harm should be taken seriously. Determining some of the following risk factors may be helpful:

1. The presence of depression and a hopeless or bleak outlook.
2. The loss of friends or relatives, or of self-esteem, or of a body part or function highly valued by the patient.
3. A plan to kill oneself.
4. A lethal means (gun - pills).
5. A past history of suicidal ideation, or of a gesture or an attempt.
6. A history of drug or alcohol abuse (30 percent of suicides are alcohol related).
7. Poor health.
8. A concomitant Axis I on Axis II diagnosis.
9. A family history of suicide or major psychiatric illness.
10. The patient's estimate of risk.
11. The physician's empathetic estimate of risk.

Gesture and attempts may be difficult to differentiate, and in general should be taken equally seriously. Both may be associated with personality disorder and manipulation or they may be expressions of bona fide depression and a desire to be dead. Long-term treatment depends on correct diagnosis and a proper response to an estimate of the self-destructive risk. The medical officer should follow NAVMEDCOMINST 6520.1 series for disposition. When in doubt, hospitalize, and always follow-up. Always notify the cognizant command of your follow-up plan. Suicide patients, even those with manipulative suicide behavior, do not belong in the operational environment. The flight surgeon should closely coordinate cases of suicidal ideation or behavior with the nearest medical treatment facility.

The risk of homicide may derive either from psychiatric or organic illness and is historically nearly impossible to predict. If the etiology is functional, the following have been associated with increased homicidal risk:

U.S. Naval Flight Surgeon's Manual

1. Abusive parents, especially the father.
2. A borderline or schizoid pattern of adjustment.
3. A seductive mother.
4. A triad of cruelty to animals, fire setting, and enuresis.
5. A paranoid pattern of adjustment with chronic anger. If the illness is organic, there may be increased risk if the basic personality pattern has been paranoid.
6. A history of violent behavior or assaulting others.

The Center for the Study of the Prevention of Violence in Los Angeles has uncovered a rather high percentage (42 percent) of soft neurological signs in studies of violent patients.

In the individual case, an estimate of the following may be helpful in assessing homicidal potential:

1. The degree of unreality in the paranoid ideation.
2. The adequacy of contact with reality in general.
3. The intensity of anger.
4. The history of impulse control.
5. The adequacy and stability of relationships.
6. Self-esteem.
7. The presence of the paranoid defense as a major coping device.
8. The patient's estimate of his current control.

Studies suggest that only a very small percentage of those presenting with homicidal risk ever act on their impulse. Treatment consists of the imposition of chemical or physical controls (in the form of hospitalization) as in suicidal potential, until the danger is over. The Tarasoff court deci-

Aviation Psychiatry

sions in California has set the standard that the intended victim and police must be notified. In the military this would include the cognizant commanding officer.

Drug Overdose

The following general principles are accepted for the treatment of drug overdose:

1. Identification of the drug.
2. Evacuation via emesis and lavage.
3. Neutralization via antidote.
4. Symptomatic treatment and supportive measures.

In overdose with psychotropic medications, the following steps should be taken:

1. Ensure an adequate airway - intubation or, rarely, tracheostomy if necessary in the comatose patient.
2. Emesis in the conscious patient - syrup of ipecac, one teaspoon for a child, two for an adult. This may be repeated in fifteen minutes.
3. Gastric lavage. Do not attempt this in the comatose patient without intubation and cuff to preclude aspiration pneumonia. Use a solution of 0.5 percent normal saline activated charcoal. Continue lavage until returned solution is clear. In the case of tricyclics, one author recommends lavage for 24 hours on the basis that the excretion of tricyclics occurs partly in the stomach.
4. An I.V. with five percent glucose in saline. Maintain fluid balance. One author recommends an immediate injection of 50 cc of 50 percent glucose for saline in comatose patients considering that hypoglycemia as a possible cause is thereby quickly and simply treated or ruled out.
5. Blood and urinalysis to identify the drug, as well as a history from a reliable informant.
6. Other supportive measures as may be indicated - indwelling catheter, cardiac monitoring, treatment for shock, hyperpyrexia, and potential seizures.

U.S. Naval Plight Surgeon's Manual

It has already been mentioned that epinephrine and related compounds must be avoided for the hypotension due to the antipsychotic and antidepressant medications in order to avoid paradoxical further lowering of the blood pressure. Levophed or phenylephrine are the drugs of choice, one ampule, titrated in an I.V. drip.

If sedation is required for agitation or the danger of seizures, oral or I.V. Valium, 5 to 20 mg, appears to be the drug of choice. Where the overdose is from amphetamine or related compounds, the use of a phenothiazine for sedation may precipitate an intractable hypotensive reaction.

The central anticholinergic syndrome (CAS) may be a concomitant of overdose with antipsychotic and antidepressant drugs, as well as with the anticholinergics prescribed to relieve the pseudo-Parkinsonian symptoms induced by the antipsychotics (Holinger & Klawans, 1976).

The central nervous system symptoms and signs of anticholinergic overdose are:

1. Agitation.
2. Disorientation.
3. Hallucinations - visual and auditory.
4. Anxiety.
5. Purposeless movements.
6. Delirium.
7. Stupor.
8. Coma.

The peripheral nervous system symptoms and signs are:

1. Flushing.
2. Dry mouth.
3. Constipation.

Aviation Psychiatry

4. Mydriasis.
5. Temperature elevation.
6. Motor Incoordination.
7. Tachycardia.

Another way to remember anticholinergic overdose is by this rhyme:

Red as a beet,
Blind as a stone,
Mad as a hatter,
Dry as a bone.

These symptoms and signs are all dose related. They are the result of a competitive inhibition of acetylcholine. The antidote, physostigmine, which unlike neostigmine can cross the blood-brain barrier, inhibits the enzyme anticholinesterase, permitting an increasing build up of acetylcholine that finally overcomes the block at the receptor sites.

Profound coma and other characteristic symptoms of the CAS syndrome may be relieved immediately by the administration of physostigmine in doses of 1 to 4 mg as often as indicated, usually every hour until symptoms and signs permanently abate. This is usually no more than 24 hours, at most.

Family Crises

There are two other types of emergency with which the flight surgeon will surely be confronted. They differ in character from those described above. The first is that of the distraught, and perhaps lonely and dependent, military wife whose husband is at sea or overseas, possibly in a combat area. The second is that of the young military wife who has just lost her husband in an aircraft mishap or in combat.

In the first type, the emergency may either be real or the expression of immaturity and predominantly intrapsychic factors. If it is a true emergency, the social worker may be the proper helping person. If the symptoms are mainly intrapsychic, the flight surgeon psychotherapist, in addition to the social worker, may be necessary to support the patient. If the husband must be returned or the children need care or supervision, family services, social services, and the chaplain may need to get involved. For the stress of military separation, prevention, in the form of

preparation of the family by the military member, is by far the best form of treatment. This should include emotional preparation for the absence and the necessary shift in roles, agreements for communication by writing or other means, power of attorney for legal problems, and plans for adequate residence, medical care, financial, and other crises that may arise. Knowledge of the various helping agencies and what they can realistically do should help to allay separation anxiety and forestall emotional crises. The articles, Emotional Cycle of Deployment (Logan, 1987) and Growing Up Military (Long, 1986) will greatly assist the flight surgeon in understanding the unique stressors of military life.

At some time the flight surgeon will surely be called upon to accompany the chaplain and commanding officer to notify a young wife of the loss of her husband in an aircraft mishap or in combat. Recalling the stages normal to grief reactions, the flight surgeon will realize that one of the most important elements of treatment is helping the patient and encouraging the relatives to help the patient to experience, ventilate, and express her feelings, whatever they may be. Sedation or tranquilization should therefore be minimal, but the patient needs at least enough sleep to function. Prescribing Halcion 0.25 HS, for several nights may be very helpful in supporting the patient through the most trying period. It may also be important to have a friend or relative of the patient's choosing stay with her for a day or so, particularly if she would otherwise be alone. Remember to fully utilize the service of the unit CACO - casualty assistance and counseling officer .

Combat Psychiatry

In combat and other sustained operations, including aviation combat, the emphasis in understanding psychological reactions is on the external stress. The symptoms and signs run the full gamut of psychiatric nomenclature, but quick recovery is the rule when the patient is removed from the stress. Experience has shown over and over that if a combatant is treated quickly, close to his unit, and led to expect that he will return as soon as possible to his unit, results are not only very good, but far superior to those obtained when a man is treated a long way from his buddies, with some delay, and with uncertain expectations. The cardinal principles of combat psychiatry are Proximity, Immediacy, and Expectancy (PIE). Historically these principles are "relearned" at the beginning of each new conflict.

Principles Further Refined During the Korean War

1. Treat as near to the unit as possible.
2. Segregate the most agitated patients until they can be adequately sedated.

Aviation Psychiatry

3. Sedate sufficiently to reduce overwhelming anxiety and insure sound sleep.
4. Accept the patient not as a casualty, but with the attitude that his symptoms are transient and that he will recover and go back to his unit.
5. Say or do nothing that would indicate evacuation.
6. Ventilation is encouraged; interpretation avoided.
7. Once disposition is decided, inform the patient, avoiding argument.
8. Return the patient to duty as soon as possible, often within 24 hours.
9. As a guideline, evacuate patients with the following conditions.
 - a. The obviously psychotic - rare in combat.
 - b. Conversion reactions - the blind and paraplegic.
 - c. The severely apathetic who appear emotionally depleted.
 - d. Those who show gross tremor and chronic startleability.
 - e. The NCO or officer with impaired judgment or who may set a bad example.

“Combat fatigue” has been defined as a transient, pathological reaction in a basically healthy personality to the severe stress of combat. The terminology tends to be confusing. By DSM III-R criteria, acute reactions would fall into acute traumatic stress syndromes. Later symptoms would be in the posttraumatic stress syndrome category.

Frequently Used Mnemonic: “BICEPTS”

- B - Brevity* - Treat for as short a period as possible to return to function, 48 hours at the first echelon.
- I - Immediacy* - Intervene before the individual is incapacitated.
- C - Centrality* - Triage and locate combat fatigue cases away from the wounded, in a central area.

U.S. Naval Plight Surgeon's Manual

E - Expectancy - From the beginning, the patient is given the expectation of returning to his unit.

P - Proximity - Treat as close to his unit as possible.

T - Treatment - Should include rest, food, warmth and short acting sedatives if necessary.

S - Simplicity - Front line measures should be simple and easily monitored.

For disasters involving multiple casualties and death, rapid intervention by trained professionals will assist in alleviating long-term symptoms in both survivors and rescuers (posttraumatic stress syndrome). The SPRINT teams (Special Psychiatric Rapid Intervention Teams) at the Naval Hospitals San Diego and Portsmouth are available for rapid on-site assistance.

The Psychology of Survival And The Repatriated Prisoner of War

General Concepts

With today's ultramodern communications and locating devices, one is much less likely to be faced with surviving in a hostile geographic environment than as a prisoner of war (POW). Some of the helpful techniques and concepts that have been learned or proven from the Vietnam experience are included in this discussion from the point of view of a captured pilot.

Family Preparation

A family's ability to face and survive a long period without the head of the family will be measurably enhanced if they prepare for it ahead of time, before his deployment. In the event of capture, the prisoner can then be somewhat less worried about how his family is managing. The military member should prepare his wife and children, within the limits of their emotional comprehension, for the shift in responsibilities and roles that his absence will entail. He should consider granting power of attorney and prepare his wife for any legal problems that can be foreseen. He can provide plans for residence, medical care, financial, and other crises that may arise in the event of his capture and imprisonment.

"Shoot Down" and Culture Shock

For a few pilots shot down in the Vietnam conflict, the abrupt transition from the highly ordered, time-structured, mechanized world of the cockpit to the anachronistic, agrarian, il-

literate world on the ground was momentarily disorganizing, producing a feeling of unreality. This persisted until one set about laying realistic plans and trying to cope, even though captured. The best preparation for this stress should be SERE (Survival, Evasion, Resistance, and Escape) school.

Coping in Captivity

There are many things that one can do in captivity to enhance the ability to survive.

The greatest single shock to the POW was breaking under torture, and the unbelievable rapidity with which it could happen. It simply did not fit with the POW's image of himself as a red-blooded American fighting man. This rent the man from his identification with his group and produced enormous guilt and depression that could usually only be alleviated by sharing the experience with a fellow POW. His understanding and encouragement brought the first man relief and repaired the rift.

Although the Code of Conduct was a rallying point, it was meant to be applied flexibly, and it is so stated in the Code. Those who applied it rigidly because of their early SERE training were prone to be broken needlessly over information or behavior of minimal value. Unified resistance was extremely important for morale, and it made each POW much less vulnerable to the enemy's blandishments and torture. But, the POW's soon learned that it made more sense not to resist to the point of confusion or insensibility because, then, one might give truly valuable information to the captor without realizing it. It was better to stop just short of that point and give some misleading or useless bit of information.

In the oriental environment of Vietnam, saving face was an important concept in the give-and-take with the captor. If the captor was required by his superiors to extract a bit of information or behavior from a POW, he had to return with something. It did not matter what it was or, at times, even whether it made sense; knowing this could sometimes save a POW needless injury. Conversely, if one could figure out how to put the captor in one's debt, the face-saving concept could again be turned to advantage for the POW, with the captor overlooking some bit of forbidden behavior or perhaps providing medical care.

Saving face was also a problem for some of the POW's who felt constrained to "go to the mat" at the slightest provocation from their captor. It often took several beatings for a POW to realize that this was a foolish and losing game and that pride consisted of more important things.

Torture could be and was applied again and again over weeks and months. The POW's learned

roughly how much they could endure before breaking, that they could recuperate, and, depending on the gravity of the injuries inflicted, about how long it would take. They gradually realized that one could survive even extensive torture, and this in itself was reassuring. This realization underscored the importance of keeping fit to improve to the utmost one's recuperability. Three to four hours a day might be devoted to physical fitness exercises of various sorts. POW's soon appreciated that "healthy bodies meant healthy minds." Food was equally important in this regard. The POW's learned to eat things that were normally revolting, though of some nutritional value. It has been shown from earlier wars that weight loss in captivity was the only apparently significant variable which could be related to disability which developed as late as eight to ten years after repatriation.

Shortly after capture, the POW was tortured to extract short-lived information. Then, he was normally isolated, sometimes for months, even years. To avoid boredom, depression, or a break with reality, the POW had to "keep busy." This could be done either inside or outside one's head. One had to be involved, to move into some kind of future, even, paradoxically, if it meant exploring the past. One of the first things a POW did was to go over his entire life, in a piecemeal fashion. This might take three to four months; the longer, the better. He would recall events or people he had not thought of in years. He might, for example, recall everyone in his third grade class. He reevaluated all the decisions and choices he had made. Sometimes major shifts in values occurred. It was a private psychoanalysis. This process could be repeated several times before it burned itself out. Then, the POW might engage in imaginary activities, such as building an entire housing subdivision or a house or a truck, brick by brick or bolt by bolt. Others who could communicate studied languages, history, or philosophy, played chess or worked calculus problems. Some studied the local insects, playing games or experimenting with them. Depressing thoughts had to be avoided. As one POW put it, "they could ruin your day."

The need to communicate with fellow prisoners was so strong that one would risk torture to do so, and all sorts of measures were devised. A tap code could be sent by tapping, sweeping, spitting, coughing, etc. Carbon or the lead from toothpaste tubes was used to scribble notes left in secret hiding places.

Communication was the cornerstone of another basic necessity for survival - unity and group identification, with a hierarchy of leadership. As one POW put it, war with the enemy had not ceased upon ejection from his aircraft; only the mode and the front had changed. As "home with honor" was the slogan for survival, unity and communication were the means by which it was achieved. If a man was not incorporated quickly into the communication network, he was fair game for the enemy to divide and conquer. The tactics of the captor were to find weak links among the POWs and then to persuade them to collaborate either by force, leniency, deception,

Aviation Psychiatry

or blackmail. Leaders especially were their targets, and they suffered most. A few were isolated for several years to sequester them from their men and they were subjected to frequent and intense torture.

In this connection, the prisoners were subjected to incessant propaganda and classes in communist ideology. Most authorities reject the term "brain-washing" because it suggests that by some magical and nefarious means the prisoner's mind is erased clean of former convictions and loyalties, and these are supplanted by communist ideology and attitudes espoused willingly and permanently. They prefer the term "thought reform," which is a lengthy process of confession and persuasion in a group setting by the behavioral conditioning of reward and punishment. Successful thought reform, however, requires that the prisoner have been brought up in an environment where group orientation is a very strong and potent force for influence. The methods of the Vietnamese captors were regarded as crude by Western POW's and were essentially ineffective. Any propaganda that appeared to have been absorbed was quickly repudiated when the pressure was removed. The few exceptions were those POW's who had been extremely naive, passive, rootless, or isolated in their own countries, with no firm convictions or loyalties to begin with.

In other times and places, more forceful and relentless tactics, such as drugs, sensory and sleep deprivation, torture, and endless interrogation were applied to a few persons with results that might be termed "brainwashing," but even here there is room for doubt.

This does not mean that one cannot be made to lose one's sensibilities for a time, to become disoriented, or even subject to hallucinations, but at least one can be reassured that this is not a permanent state of affairs.

Organic brain syndromes with hallucinations occurred in the context of physical abuse, sleep deprivation, or malnutrition, or a combination of all of them. These symptoms remitted and at the present time there is no sign of residual symptoms. This again provides reassurance that one can survive and even recover from enormous amounts of physical abuse and torture. Realizing this ahead of time can add to one's survivability by relieving a person of much of the fear of anticipated permanent disability.

Sexual functions appeared not to be a problem in captivity or after repatriation as some prisoners feared.

Some POW's worried about dreaming at first, until they discovered that they only dreamed pleasant escape dreams. These dreams always ended, however, with the necessity for returning to the prison environment. When one prisoner in his dream refused to go back, he claimed he never dreamed again in captivity.

There is a suggestion that a certain amount of time, somewhere between six weeks and six months, was required to adapt to the shock of capture and captivity. The time was necessary for anxiety and depression to subside to at least tolerable levels so that the individual could begin to function again, to move ahead in his daily life, and to contemplate a future, however uncertain and bleak. A few who were repatriated with a shorter period of captivity were still likely to be quite anxious and to have difficulty sleeping, making decisions, performing complex manual tasks, and thinking, concentrating, and remembering. This may be an aspect of the initial depression because the symptoms are similar to those of any typical depression, and the time required to adapt reflects the time typically required to recover from an untreated depression in any other setting. Frequently, this period of depressive symptoms was terminated, often rather abruptly, when the prisoner made a firm decision to survive and began to look and plan ahead. Recovery was especially facilitated by the relief of sharing his initial capture and torture experience with a fellow POW.

Repatriation

In captivity, time to think, to ponder, to deliberate, to make the most minute, inconsequential decision, was abundant. When repatriation finally occurred, the pressure of events and people and, by contrast, the frequent demand for rapid, important decisions and for equally rapid role reintegration resulted in reentry or reverse culture shock. This often was as stressful and devastating for a few as the initial one. This might last from as little as a month to as long as a year. It was variously reflected in persistent anxiety, insomnia, indecision, depression, difficulty driving, and for a few, excessive drinking. In most cases, marital discord was the commonest expression. This discord was often intensified by unconscious hostility on the part of the wife over having been abandoned (during captivity) and was compounded by her realistic anger if the repatriated prisoner of war (RPW) seemed thoughtlessly to allow his time to be monopolized by well-meaning relatives, friends, and well-wishers, numerous banquets, public appearances, and requests for speeches to which he felt obligated to respond. Regardless, the great majority of the RPW's negotiated repatriation successfully.

Conclusion

Personality and temperament are undoubtedly important variables not only in coping with torture, but also in unwittingly inviting it. The Center for Prisoner of War Studies is exploring these variables and their relation to resistance postures. Does the hysteric unconsciously invite torture by "going to the mat" at every provocation no matter how slight; does the passive or schizoid person escape attention; is the compulsive person more apt to capitulate and cooperate or, through rigidity, to bring excessive torture upon himself? How does the intensely sensitive person fare or the calm, tough-minded individual, with a high threshold for anxiety and pain?

Aviation Psychiatry

In retrospect, it would appear that survivability from shootdown to repatriation ultimately depends upon and requires recovery of self-esteem through reintegration with the group - the POW group in captivity and the military, the family, and society at large upon repatriation. To the degree that there is failure in this, there will be symptoms and signs of psychopathology.

References and Bibliography

- Alexander, F., & French, T.M. *Psychoanalytic therapy principles and applications*. New York: Ronald Press, 1946.
- American Psychiatric Association. *Diagnostic and statistical manual of the American Psychiatric Association, DSM III-R*. Washington, DC: American Psychiatric Association, 1987.
- American Medical Association. *Drug evaluations* (6th Ed.). Chicago: AMA 1986.
- Appleton, W.S. Third psychoactive drug usage guide. *Diseases of the Nervous System*, 1976, 39-51.
- Basch, Michael F. *Doing psychotherapy*. New York: Basic Books, 1980.
- Dahlstrom, W.G., & Welsh, G.S. *An MMPI handbook: A guide to use in clinical practice and research*. Minneapolis: University of Minnesota Press, 1960.
- Dahlstrom, W.G., Welsh, G.S., & Dahlstrom, L.E. An MMPI handbook, Volume 1: *Clinical interpretation*. Minneapolis: University of Minnesota Press, 1972.
- Hanke, N. *Handbook of emergency psychiatry*. Lexington, MA: Collamore Press Dil, Heath and Company, 1984.
- Holinger, P.C., & Klawans, H.I. Reversal of tricyclic-overdosage-induced central anticholinergic syndrome by physostigmine. *American Journal of Psychiatry*, 1976, 133, 1018-1023.
- Kolb, L.C. *Modern clinical psychiatry*. Philadelphia: W.B. Saunders Co., 1982.
- Long, P. Growing up military. *Psychology Today*, December 1986, 31-37.
- Logan, K.V. The emotional cycle of deployment. *Proceedings*, February 1987, 43-47.
- Mann, J. *Time-limited psychotherapy*. Cambridge, MA: Harvard University Press, 1973.
- MacKinnon, R.A., & Michels, R. *The psychiatric interview in clinical practice*. Philadelphia: W.B. Saunders, 1971.
- Munoz, R.A. Treatment of tricyclic intoxication. *American Journal of Psychiatry*, 1976, 133, 1085-1087.
- Reinhardt, R.F. *Fear of flying*. Presentation at the Annual Meeting of the American Psychiatric Association, May 1965.
- Reinhardt, R.F. The outstanding jet pilot. *American Journal of Psychiatry*, 1970, 127, 732-735.
- Sadock, V. Marital therapy. In B. Sadock, H. Kaplan, & A. Freedman (Eds.), *The sexual experience*. Baltimore: Williams & Wilkins, 1976.
- Sadock, B.J., & Kaplan, H.I. *Comprehensive textbook of psychiatry*. Baltimore: Williams & Wilkins, 1985.
- Strange, R-E., & Arthur, R.J. Hospital ship psychiatry in a war zone. *American Journal of Psychiatry*, 1967, 124, 281-286.
- Sonnenburg, S.M., Blank, AS., & Talbott, John A. (Eds.). *The trauma of war: Stress and recovery in Vietnam veterans*. Washington, DC: American Psychiatric Press, 1975.

U.S. Naval Flight Surgeon's Manual

Talbott, J.A., Hales, DE., & Yudofsky, S.C. (Eds.). *Textbook of psychiatry*. Washington, DC: American Psychiatric Press, 1988.

Wolpe, J., & Lazarus, A. *Behavior therapy techniques*. New York: Pergamon, 1966.

APPENDIX 6-A

OUTLINE FOR PSYCHIATRIC REPORTS

Report Outline

The outline for consultations and reports should correspond to the traditional medical format:

1. Identifying information and symptoms and signs. (CC)
2. Patient profile according to the PROMIS system.
3. Context - event or situation precipitating the symptoms and signs. (PI)
4. Background history - the personality. (PH)
5. Mental status examination and psychometrics. (PE)
6. Summary statement correlating 1, 2, and 3. (DX)
7. Diagnosis and complementary statements.
8. Recommendations; therapy plan. (RX)

Report Format

For brevity's sake, certain phrases and items of information should be constant.

Paragraph 1. Identifying Information

This is a standard paragraph and is always in the same format:

This year old (marital status), (rank/rate), with about years of continuous active (broken) service, was referred for psychiatric evaluation on from (activity) , with the diagnosis , because of (symptoms and signs).

Paragraph 2. Patient Profile

A brief outline of the patient's every day world, responsibilities and stressors.

U.S. Naval Flight Surgeon's Manual

- a. Unit assignment.
- b. Responsibilities.
- c. Performance.
- d. Where he lives and with whom.
- e. Stressors.
- f. Patient's perception of his referral.
- g. Administrative or legal difficulties.

Paragraph 3. - Present Illness

- a. Details of onset of present symptoms as presented by patient.
- b. Why now.
- c. Patient's perspective on his behavior.
- d. Include information secured from other sources.
- e. Behaviors or significant changes in patient's attitude noted during the evaluation.

Paragraph 4. Past History

- a. Family:
 - (1) Parents' marital status, geographic, and socioeconomic data.
 - (2) Patient's sibling rank and parent's sibling rank.
 - (3) Family history of mental illness, suicide, or psychiatric hospitalization.
- b. Personal:
 - (1) Early childhood events.

Aviation Psychiatry

(2) Adolescence: behavior problems, hetero or homosexual development and experience, friends and social adjustment, interests and hobbies.

(3) Substance abuse.

c. Social:

(1) Disciplinary problems.

(2) Educational level achieved.

(3) Marital relationship history.

(4) Plans and goals.

(5) Work history, dismissals.

(6) Military adjustment.

Paragraph 5. Mental Status and Psychological Testing

Mental status examination is referred to in previous parts of this outline. A “normal” mental status examination might be written as follows:

a. The patient was dressed in appropriate military attire, he was well groomed, pleasant and cooperative. He sat comfortably in the examining chair exhibiting no unusual signs of anxiety. His speech was logical and coherent with his thought pattern focused on his difficulty in getting along with his superiors. He described his mood as “upset” but had an appropriate wide range of affect. The patient exhibited no psychotic tendencies. The patient denied suicidal ideation. The patient denied homicidal ideation. He was alert and oriented to time, person, place, and situation. His intelligence was clinically judged as average. The patient’s memory, including past, recent, and immediate recall were adequate. The patient’s cognition and abstraction were determined to be adequate. The patient’s insight and judgment were adequate. The MMPI was read as valid and not suggestive of overt psychopathology.

b. It may be helpful to memorize this outline:

(1) General appearance.

- (2) Speech and coherence of thought.
- (3) Mood and affect.
- (4) Perception - psychotic symptoms.
- (5) Suicidal or homicidal thoughts.
- (6) Orientation.
- (7) Memory.
- (8) Intelligence level.
- (9) Cognition and abstraction.
- (10) Insight and judgment.
- (11) Psychological testing.

Paragraph 6. Summary and Formulation

- a. Brief correlation of symptoms, stressors, and personality traits.
- b. How they combine to produce a working diagnosis or no diagnosis.

Paragraph 7. Multiaxial Diagnosis

- a. Axis I: Clinical syndromes or V codes.
- b. Axis II: Personality trait disorders, specific developmental disorders.
- c. Axis III: Physical conditions or disorders.
- d. Axis IV: Severity of psychological stressors (0 - 7).
- e. Axis V: Global assessment of functioning scale (absence of symptoms to grossly impaired).

Paragraph 8. Recommendations.

Military psychiatric recommendations usually include two parts: administrative recommendations, and therapeutic recommendations. Medical recommendations would include any therapy indicated, any need to return for further therapy or referral if necessary.

a. Administrative statements:

- (1) PQ and AA.
- (2) Is/Is not considered a significant suicidal or homicidal risk.
- (3) Fit for duty and responsible for his actions.
- (4) Recommend administrative management IAW - *Instruction number with month and year of issue.*

b. Medical/psychiatric:

- (1) Personal therapy.
- (2) Marital and family therapy.
- (3) Environmental manipulation.
- (4) Referral to other appropriate source.

APPENDIX 6-B

PSYCHIATRIC STANDARDS FOR NAVAL AVIATION

**A Reference Guide for Flight Surgeons, Psychiatrists, and Psychologists
with Suggestions for Further Medical Disposition.**

References

1. U.S. Navy Manual of the Medical Department, Chapter 15, Article 67.
2. U.S. Navy Manual of the Medical Department, Chapter 18, Medical Disposition.
3. SECNAVINST 1850.3 Series, Physical Disabilities.
4. MILPERSCOMINST 1910.1 series, Administrative Separation.
5. SECNAVINST 1920.6 series, Administrative Separation of Officers.
6. MILPERSMAN 3620200, Administrative Separation.
7. CNO Message 201614Z FEB 87, 9 NAVOP 13/87.
8. Aeronautical Advisory Committee, NAMI, Minutes of 24 April 1989.

Psychiatric Disorders (DSM-III-R) as They Relate to Naval Aviation

In most cases these determinations are appropriate to any special duty or operational setting. (From Reference Guide, dated May 1989).

Mental Retardation. Determination of NPQ for aviation or general duty. Refer to a Medical Board for action as a noncompensable disability.

Pervasive Developmental Disorders. Are disqualifying for enlistment and not usually encountered as an active duty problem.

Specific Developmental Disorders. Result in a determination of NPQ for aviation if the skill involved impacts on aviation training, as is usually the case. Suitability for general duty may have to be addressed by a Medical Board as an EPTE (Enlisted Prior to Entry) disorder.

Aviation Psychiatry

Disruptive Behavior Disorders. Determination of NPQ for aviation. They are best managed by a Medical Board and referral to Naval Military Personnel Command, NMPC, for administrative action.

Anxiety Disorders of Childhood/Adolescence (History of). Individual is usually not allowed to enlist. If symptoms are active, individual is NPQ for aviation and general duty. Refer for departmental review as an EPTE disorder.

Eating Disorders. Anorexia nervosa and bulimia nervosa both result in a determination of NPQ for aviation due to the recidivism and complications of the illnesses. Attempts at treatment in the military setting are not practical or cost effective. These cases are best referred via a Medical Board for departmental review.

Gender Identity Disorder. Determination of NPQ for aviation. Proper management may necessitate referral to NMPC via NAVMEDCOM departmental review.

TIC Disorders. If very mild, military member would be considered NPQ for aviation with a waiver recommended. If severe enough to impact on a patient's professional performance or social interaction in the squadron, this condition would result in a determination of NPQ with no waiver recommended. Referral via Medical Board departmental review to NMPC is indicated.

Elimination Disorders. Determination of NPQ for aviation. MANMED considers enuresis past age 16 as disqualifying for general service. Management is in accordance with MILPERSMAN 3620200.

Speech Disorders - Not Elsewhere Classified. Individual should be considered NPQ for aviation.

Dementias. Result in a determination of NPQ for naval aviation and for general duty. These cases should be referred to NAMI Physical Examinations Department via a Medical Board. This is a compensable disorder.

Psychoactive Substance Induced Mental Disorders and Substance Dependence. Result in a determination of NPQ. *Alcohol abuse* results in a finding of NPQ until satisfactory completion of Level II. *Alcohol dependence* results in a finding of NPQ. DSM-III-R criteria should be followed. After treatment at Level III, in accordance with MEDCOMINST 5300.2, a waiver can be recommended. *Illicit substance abuse* acknowledged and waived by the Recruit Command prior to acceptance into naval aviation is not considered disqualifying. Repeat use of illicit

substances (treatment failures) will result in a finding of NPQ and should be managed in accordance with OPNAV 5300.4. In cases of Level II or Level III treatment, it is imperative that a copy of the treatment summary be forwarded to NAMI (Code 42).

Organic Mental Disorders. Delirium should be managed appropriately in the context of the precipitating circumstances. If the precipitating organic factors are identified and considered not likely to recur, the patient may be considered PQ. Antabuse psychosis is an example of this. Physical illness or other disorders causing persistent delirium are permanently disqualifying and should be referred to a Medical Board. All other categories of organic mental disorders are physically disqualifying for naval aviation.

Schizophrenia. Individual is NPQ for aviation or general duty, refer to Medical Board. This is a compensable disorder.

Delusional (Paranoid) Disorder. Individual is NPQ for aviation or general duty, refer to Medical Board.

Psychotic Disorders Not Elsewhere Classified. Result in a determination of NPQ for naval aviation. The relapse rate, in an operational setting, of such diagnoses as brief reactive psychosis and psychotic disorder not otherwise specified is felt to be high and unpredictable. These should be referred to Medical Board and departmental review for determination of continued service.

Mood Disorders.

1. *Bipolar Disorder.* Individual is NPQ for naval aviation and usually for general duty. This is a compensable disorder and a Medical Board referral to PEB is indicated.

2. *Major Depression, Single Episode.* without complications, should be treated under the auspices of a Limited Duty Medical Board. When the individual is free of symptoms for one year without medication, a waiver to return to flight status could be considered.

3. *Major Depression, Recurrent.* individual is considered NPQ for naval aviation and usually should be referred by Medical Board to PEB as this condition, if recurrent, usually impacts on satisfactory performance of general duty.

4. *Dysthymia.* Usually results in a determination of NPQ for naval aviation and for other special duty. The patient should appropriately be treated on a Limited Duty Medical Board. If symptoms remit, and the patient is free of symptoms for one year, he could be considered to

Aviation Psychiatry

return to flight status by submission of a waiver. Recurrent or unremitting dysthymic episodes should be referred by a Medical Board to PEB for determination of continued duty.

Anxiety Disorders.

1. *Panic Disorder.* Individual is NPQ for aviation. If treatment is indicated, this should occur under the auspices of a Limited Duty Medical Board. When free of symptoms and medication for one year, the patient could be returned to an aviation status by waiver request. The patient should not be returned to full duty while still having active attacks or requiring medication to control the attacks.

2. *Social Phobias.* Result in a determination of NPQ if the behavior impacts on the patient's professional performance. Refer via a Medical Board for departmental review.

3. *Simple Phobias.* If they impact on the performance or safety the individual is considered NPQ. If the symptoms impact on shipboard life or general duty, (as claustrophobia), the problem should be referred to PEB, usually as an EPTE disorder.

4. *Obsessive-Compulsive Disorder.* Results in a determination of NPQ for aviation. Refer to PEB for determination of continued duty.

5. *Postrumatic Stress Disorder (PTSD).* The individual is NPQ for aviation. If the symptoms require ongoing treatment, the patient should be treated under the auspices of a Limited Duty Medical Board. A waiver for naval aviation will be considered if the patient remains symptom free for one year. Continued symptoms should be referred by a Medical Board to PEB for disability determination.

6. *Generalized Anxiety Disorder.* Individual is considered NPQ and referred by a Medical Board to PEB. Treatment rendered should be under the auspices of a Limited Duty Medical Board.

Somatoform Disorders. Result in a determination of NPQ for naval aviation, and if treated, should be under the auspices of a Limited Duty Medical Board. Continued symptoms, or severe symptoms, warrant referral to PEB.

Disassociative Disorders. Result in a determination of NPQ for naval aviation. The individual should be referred for departmental review for a determination of continued duty.

U.S. Naval Flight Surgeon's Manual

Sexual Disorders. As a general rule do not impact on a person's aviation performance. If they do, the individual is considered NPQ. If the patient becomes professionally dysfunctional due to his sexual disorder, he can be referred by Medical Board for departmental review to evaluate continued service. Paraphilias are a common occurrence, and in general, the individuals are PQ and AA. Many cases are more appropriate for administrative disposition because of the social consequences that impact on military order and discipline.

Sleep Disorders. Result in a determination of NPQ for aviation. Those with disorders, such as narcolepsy, should be referred by Medical Board to PEB. Somnambulism should be managed in accordance with MILPERSMAN 3620200.

Factitious Disorders. Individual is considered NPQ and should be referred to Medical Board and departmental review for evaluation of continued service.

Disorders of Impulse Control. Individual is considered NPQ for naval aviation and should be referred by Medical Board for departmental review to evaluate for continued service. Administrative and legal difficulties may preclude medical management.

Adjustment Disorder. Results in a determination of NPQ for aviation while the patient is in the active phases. When the adjustment disorder can be described as "resolved," the patient can be considered fully physically qualified and returned to active flight status. Be sure that symptoms and stressors meet DSM-III-R criteria and do not use this as a "wastebasket" diagnosis or as a "less demanding" diagnosis to cover more serious pathology.

Psychological Factors Affecting a Physical Condition (Psychosomatic). Result in a determination of NPQ if the physical symptoms are such that they impact on the individual's performance. On occasion, a waiver for aviation may be appropriate. If general duty performance is impacted, or inordinate medical support is required, the member should be referred to the PEB.

V-Codes. In general individuals are considered PQ unless an inordinate amount of impairment or treatment becomes necessary. If this occurs, a concomitant Axis I or Axis II diagnosis should be seriously considered.

Personality Disorders and Severe Maladaptive Personality Styles. In aviation personnel usually result in a finding of NAA.

In deploying units, ships and isolated duty stations, aviation and nonaviation personnel with maladaptive behavior can be a hazard to mission completion. Special care should be taken in

Aviation Psychiatry

evaluation of patients with suicidal behavior or other impulsive self-harm behavior. Because of the high incidence of suicide and poor tolerance to stress, persons diagnosed as borderline personality disorder should not be sent back to an operational unit for management. This is crucial if the unit is in a deployed status. Those with paranoid and schizotypal personality disorders are also unusually prone to turmoil and disruptive behavior and are very difficult to manage in the operational environment. Instructions previously noted give guidance in management and administrative separation of those with personality disorders.

Waivers

Waivers for some conditions are possible if the condition is resolved or in prolonged remission (usually at least one year) and if the chances for relapse are considered minimal. Requests for a waiver are submitted by the cognizant flight surgeon along with a copy of the psychiatric evaluation and current flight physical.

Standards

Only by adhering to set standards with continued communication between mental health professionals in the Navy, can we hope to maintain the quality and best functional capability of our operational forces.

Further Information

For further information, clarification or guidance in aviation disposition:

Psychiatry Department (Code 21)
Naval Aerospace Medical Institute
Naval Air Station
Pensacola, Florida 32508-5600

Phone: Autovon 922-4238/3974
Commercial - (904) 452-4238/3974

Acknowledgments

Special thanks to Captain Ben Ogbum, former Head, NAMI Psychiatry Department, for his editorial review and to Captain Noel Howard, Medical Member of the Navy Disability Evaluation System for their assistance in formulating the suggestions for further medical disposition.

This reference guide was prepared with the assistance and support of NAMI (Code 42) -Aerospace Physical Qualifications - and the Aeromedical Advisory Council.

CHAPTER 7

NEUROLOGY

Introduction

General Neurological Examination

Headaches

Seizures and Other Spells

Vertigo and Disequilibrium

G-Induced Loss of Consciousness (G-LOC)

Management of Coma and Unresponsiveness

Disposition of Naval Aviation Personnel Following Head Trauma

Management of Acute Spinal Cord Injuries

Common Spine and Peripheral Nerve Problems

Central Nervous System Infections

References and Bibliography

Appendix 7-A Cognitive Capacity Screening Examination: Mini Mental Status Exam

Appendix 7-B Galveston Orientation and Amnesia Test (GOAT)

Appendix 7-C Neurological Examination Form

Appendix 7-D Approach to New Onset Seizures

Appendix 7-E Approach to Status Epilepticus

Appendix 7-F Syncope Test Battery

Appendix 7-G Vestibular Function Testing

Appendix 7-H Spine and Nerve Evaluation

Introduction

This chapter is written for the practicing flight surgeon who will frequently encounter patients with neurological complaints in his day to day practice. Two aspects to be covered here are common neurological complaints and life threatening neurological disorders. This chapter is to provide basic guidelines so the flight surgeon may adequately diagnosis and treat these conditions. In addition, significant emphasis will be placed on aeromedical disposition. As the flight surgeon will inevitably find himself in a situation where neurological consultation and expensive neurodiagnostic testing are not readily available, emphasis will be placed on the history and examination as an aid to neurological diagnosis and treatment.

General Neurological Evaluation

The neurological history and physical examination has, as their primary goals, determining placement of the lesion in the neuroaxis and establishment of a pertinent differential diagnosis. It would be adequate to be able to identify the region of the neuroaxis affected at the level of:

1. The cerebral hemisphere (i.e., supertentorial)
2. The brain stem or cerebellum (i.e., intratentorial)
3. The spinal cord level
4. Peripheral nerve and/or nerve root
5. Muscle.

In addition, be aware that musculoskeletal problems in isolation can present as neurological complaints.

The general neurological differential diagnosis can be remembered by using the mnemonic VIN DIITTCH MD:

- V - vascular
- I - infectious
- N - neoplastic
- D - demylinating
- I - idiopathic
- I - immune
- T - trauma
- T - toxic
- C - congenital
- H - hereditary
- M - metabolic
- D - degenerative

Every effort should be made to obtain a thorough history with specific emphasis on the patient's chief complaint. It is helpful to establish the temporal relationship of the patient's symptom or sign, including onset, course, and resolution of complaint or neurological deficit with respect to time. The time course of a disease process will often be a clue to the most likely etiology. For example, a chronic, slowly progressive condition might be indicative of a neoplastic or degenerative process, whereas an intermittent condition would suggest a vascular or demyelinating condition. With severe, sudden or recurrent neurological complaints, consideration should be made for early presentation of a potentially life threatening condition.

Neurology

The mnemonic LEARNIT can be applied in the taking of a history of neurological complaints, particularly pain syndromes:

- L - location
- E - exacerbating factors
- A - alleviating factors
- R - radiation
- N - nature
- I - intensity
- T - timing

The past medical history should include potential occupational problems such as exposure to toxic substances and solvents in the work place, high intensity noise exposure, overseas travel in an area endemic for certain tropical diseases, etc.

The examination should include the overall general physical examination with attention directed to the head, spine and extremities. Congenital or hereditary problems would be suggested in someone who has dysmorphic facial features, subtle differences in extremity size, flat feet or high arched feet, etc. The neurological examination traditionally begins with the mental status examination. Generally this is a part of the overall response of the patient to the doctor; however, should the patient be complaining of specific problems of thinking, such as memory or decline in work performance, further mental status examinations should be performed. Formal mental status tests include the Mini Mental Status Exam (MMSE) (APPENDIX 7-A), the Galveston Orientation and Amnesia Test (GOAT) (APPENDIX 7-B), and Halstead Reitan Test Battery.

Mental Status Examination

The mental status examination includes level of alertness, orientation to person, place and time, affect, and physical appearance. An evaluation of memory function would include immediate recall - digit span (forward and reverse), short term memory - object recall after three minutes or the ability to recall a previously told short story, and remote memory tests - past presidents, or specifics of the patient's past collaborated from the member's service jacket or health record. The patient's level of education can be estimated by the FAR/AQT or enlisted AF-QT. Judgment, insight, and abstracting ability may be tested by asking the patient to interpret proverbs or make comparisons between similar objects. Calculations can be tested by having the patient subtract seven from 100 and each successive number or by telling how many nickels are in a \$1.35 or some other coin exchange problem.

The next section of the neurological examination is an evaluation of the cranial nerves. In a patient complaining of visual difficulties, visual acuity, monocular color vision, and visual fields should be tested. Refractive error can be compensated for as a cause of decreased visual acuity while having a patient stare through a pin hole or rerefracting him. The pupils should be measured in a light and dark background and a record made of the pupil size response to direct light and accommodation. The pupils should react to the same degree with the same light source and the patient can be asked if the lights have the same brightness in either eye. An unequal response or subjective difference in light intensity is suggestive of optic nerve disease and is manifested by an afferent pupillary defect (APD) or Marcus Gunn pupil. Difference of shade of a red colored object with either eye covered would be an indication of an subtle optic nerve disease. Visual fields may be tested by finger count confrontation, with stationary fingers placed in the central 30 degrees of vision and the patient asked to give the total number of fingers. All four quadrants should be tested in each eye separately. The fundiscopic examination should include the optic disk, macula, blood vessels, nerve fiber layer, and as much of the surrounding retina area as possible. Several conditions of disc elevation simulate papilledema, such as myelinated nerve fibers, or optic nerve drusen.

The extraocular muscle examination should include a comment on eyelid symmetry. The eye muscles should be tested in the six cardinal fields of gaze and taken to their endpoint. Subtle clues of eye muscle imbalance include corneal light reflex asymmetry with the eyes in the cardinal fields of gaze, or when more scleral margin is seen in one direction than in another. The eyes are tested in the cardinal fields by turning the head with the eyes still looking at the eye chart. Formal testing using the phoropter, red lens, or Maddox rod with prism bars will give a more accurate measurement of misalignment. Eye muscle imbalance may be detected using the cover/uncover (tropia) or alternate cover (phoria) method. The patient is directed to fixate on the smallest letter visible on an eye chart and then the eye is covered and uncovered and movement of the eye from the covered to uncovered position is noted. The eyes are tested in the cardinal fields by turning the head with the eyes still looking at the eye chart. An eye that moves from inward to outward on the cover/uncover method would be indicative of esotropia. On alternate cover testing one eye is always occluded and any latent deviation of the eye is noted, deviation from inward to outward would be an example of an esophoria.

The sensory Trigeminal (V) nerve is tested by eliciting the cornea reflex or the sternutatory reflex. The corneal reflex may be tested by applying a wisp of cotton on the cornea or by gently blowing on each eye separately. The stemutatory reflex is tested by sticking a small object up the nose and looking for a blink or cough. Trigeminal motor function tests the muscles of mastication (masseter, temporalis, and pterygoids which move the jaw front, back and side to side). Facial nerve testing includes test of lacrimation (Schirmer Test), stapodial reflex (tested on

Neurology

audiograms), taste (anterior 2/3 of the tongue), and function of facial expression (forehead wrinkles, eye closure, smiling and pursing of the lips). The Glossopharyngeal (IX) and Vagus (X) nerves are tested by the gag reflex, by assessing the position of the palate at rest, by saying “ah”, and testing phonation (saying consonants ba, da, fa, la, ga). The Spinal Accessory (XI) cranial nerve is tested during the muscle exam by having the patient turn the head to either side and by shrugging the shoulders (trapezius muscles). Hypoglossal (XII) nerve function is tested by having the patient protrude his tongue forward and to either side.

Cerebellar Station and Gait Testing

Cerebellar testing includes finger to nose, heel to shin, and rapid alternating movements as well as rebound (ability to hold extremity with changing loads). Gait testing combines cerebellar, motor, and sensory function. Normal gait is tested by having the patient walk up and down the hallway, and doing rapid turns. Stress gait is tested by having the patient walk on the outsides and insides of the feet, then duck walking. This may enhance the detection of reduced arm swing or hand posturing (subtle paresis). Tandem gait testing (axial cerebellar function) is performed having the patient walk heel to toe (like a tightrope walker with eyes open/then closed). Station is tested by having the patient stand with feet together (Romberg position) with the eyes opened or closed. If done without difficulty, test next in the tandem position, with one foot in front the other and the eyes open and then closed (Tandem Romberg). Finally test in the sharpened Romberg position with the one foot in front of the other, head tilted back toward the ceiling, eyes opened then closed.

Motor Examination

Motor examination is designed to detect muscle weakness in a pattern which localizes the level of involvement (central nervous system, spinal cord, peripheral nerve, or muscle). The motor examination begins proximally and goes distally starting with neck flexion, extension, and rotation then abduction, adduction, internal and external rotation then shrugging of the shoulders. The elbow is tested in flexion, extension, pronation, and supination. Flexion and extension of the wrist is followed by finger flexion and extension then spreading of the fingers. In the lower extremities, hip flexion, extension, abduction and adduction are tested. Knee flexion and extension, ankle dorsi-flexion, plantar-flexion, then toe flexion and extension are tested. Motor strength is graded according to a 0-5 point scale, (0) being no movement, (1) being a flicker, (2) being movement of the muscle with gravity removed, (3) movement overcoming gravity but not against resistance, (4) being able to move against resistance, and (5) being normal strength. Tone of the muscle should be noted for stiffness, elasticity, rigidity, cogwheeling and the presence of postural tremor, resting fasciculation, or atrophy.

Sensory Testing

The sensory system is divided into fine sensation (carried in the posterior column of the spinal cord) or coarse sensation (carried in the spinothalamic tract). The fine sensation includes vibration, proprioception, and two point discrimination. Cortical sensation, processed from signals from the fine sensory system, can be tested by having the patient identify numbers written on the palms and soles (graphesthesia), or identifying objects placed in the palm such as coins (stereognosis). Double simultaneous stimulation, tested by applying stimuli on one side, the other, or together simultaneously, is another test of cortical sensory function. Crude sensory function, carried in the spinothalamic tracts, is tested by light touch, temperature, and pin prick.

Reflex Testing

Reflex testing is divided into muscle stretch or deep tendon reflexes, frontal release reflexes, and cutaneous reflexes. Frontal lobe reflexes include the glabellar sign, elicited by tapping on the forehead and observing the eyes continually blinking, and the root or snout reflex which is tested by having the patient look straight ahead and tapping on or above the lips, or scratching the side of the mouth and looking for a rooting contraction of the mouth. Palmomental sign is elicited by scratching the palm and observing for twitching of the mentalis muscle, just underneath the lower lip. The positive Wartenberg reflex is elicited by having the patient very gently flex the fingers against resistance and observing the thumb crossing over into the palm of the hand.

Reflex assessment of the upper extremities should include at least the biceps tendon and triceps tendon reflexes. Other reflexes that can be tested are the superficial radial (brachioradialis) elicited by tapping over the radial aspect of the forearm and the deltoid and pectoral reflexes, tested by tapping over the deltoid and pectoralis muscles respectively. The finger flexion reflexes seen with normal brisk reflexes, include Hoffman and Tromner signs. The Hoffman reflex is triggered by taking the middle finger and flicking away from the palm and observing a pincher movement between the thumb and index finger; The Tromner sign is elicited by elevating the middle finger from the rest of the hand and flicking it toward the palm again looking for the pincher movement between the thumb and index finger. These two reflexes are not necessarily a sign of pathology but rather a sign of a brisk muscle stretch reflexes. Asymmetry may be significant.

Reflexes in the lower extremity include the quadriceps reflex (knee jerk) and the gastrocnemius reflex (ankle jerk). In addition, reflexes of the hamstring muscles (biceps femoris) can also be tested. In the lower extremity the planter response, commonly called the Babinski sign, should also be tested. This extensor planter reflex or positive Babinski sign, refers to the initial dorsiflexion of the great toe upward and spreading of the other toes and is indicative of corticospinal tract

Neurology

dysfunction. This is elicited by a gentle stimulus applied to the lateral aspect of the sole in a fashion starting over the heel and extending upwards to the base of the little toe. This can also be applied to the side of the foot in a similar manner which is called the Chaddock's sign. Other reflexes similar to the Babinski sign can be tested by laterally abducting the little toe in a brisk manner and allowing it to slap back against the foot again looking for dorsiflexion of the great toe, or flicking the third or fourth toe down in a rapid manner, again looking for great toe dorsiflexion (abnormal or positive sign). These could be helpful if the patient's leg is casted and you are unable to scratch the sole of the foot.

Cutaneous superficial abdominal reflexes should be tested by scratching from the margins toward the umbilicus and observing a quivering motion of the abdominal muscles. The deep abdominal reflex is elicited by tapping over the anterior rectus abdominal muscle sheath and observing a contraction of the abdominal muscles. Other superficial cutaneous reflexes are the cremasteric reflex (in males), tested by stroking the thigh and observing the ascent of the testicles, the anal wink reflex (anus contraction to light pin prick), and the Bulbocavernosis reflex (contraction of the anal sphincter by stretching the penis). These reflexes are usually tested in spinal cord injury.

The neurological examination is directed toward the patient's chief complaint, with emphasis on important areas in the history (APPENDIX 7-C). In a patient with a rapidly evolving syndrome, the most important part of the neurological examination is reevaluation and reassessment.

Headaches

Introduction

Headache is one of the most common complaints that plague mankind and is one of the most common symptom seen by a neurologist. As aviators are aware of the implication of headaches on their flight status, the fact that they come to a physician for evaluation is indicative that their symptoms are more substantive than most patients who present to a physician with headaches. Every effort should be made to categorize the headache into a syndrome, and establish the likelihood of an organic or life threatening cause.

Pain sensitive structures implicated in headaches include blood vessels of the scalp and skin, cerebral blood vessels of the skull base (large intracranial sinuses and intracranial arteries), the dura (including the falx), and the sensory cranial nerves (V, IX, X) and the upper cervical nerves. The brain parenchyma itself is insensitive to pain. Mechanisms of pain in headache include trac-

tion, inflammation, or noxious stimulation of pain sensitive structures, distension or dilation of pain sensitive blood vessels, pressure on cranial or cervical nerves, or contraction of the cranial or cervical muscle bed. An ad hoc committee was formed in 1962 to standardize and classify headaches. They developed a classification scheme based on 15 possible headache categories. A more practical approach to headache classification divides headaches into one of three categories: (1) vascular, (2) tension (muscle contraction), or (3) traction/inflammatory headache.

Approach to Headaches

In approaching headaches in aviators it is important to ask three questions:

1. Does this headache fall into a clinical syndrome?
2. Does this headache represent a sign of a life threatening medical condition?
3. What impact does this headache have on aeromedical safety?

Of the three clinical headache syndromes, the traction/inflammatory headache is the most likely type to represent a serious medical condition. Factors suggestive of a traction/inflammatory headache include associated loss of consciousness, sudden onset of severe incapacitating headache, associated focal neurological signs, meningeal signs (stiff neck, photophobia, pain on eye movement), altered level of alertness or cognition, change in personality, or associated medical condition such as hypertension or endocrine disease. A headache associated with effort or position change, a change in headache pattern, a headache which no longer responds to treatment, or a headache in a person over age 50 may represent a serious headache. Immediate hospitalization or referral to the appropriate consultant would be indicated if there was an associated recent head injury, focal neurological deficit, sudden onset of severe headache, altered level of consciousness, papilledema, fever, hypertension, or headache in pregnancy.

The Headache History

History is very important in the evaluation of a patient complaining of headache as physical signs are rarely evident. The LEARN-IT mnemonic is useful in obtaining a history.

L is for Location. Vascular headaches tend to be unilateral in the distribution of a blood vessel. The location for muscle tension headache is usually bandlike around the front and back of the head or the suboccipital region. Traction/inflammatory headaches tends to be retro-orbital or diffuse. Although 2/3 of migraine headaches are unilateral, the possibility of an intracranial mass must be considered if recurrent headaches are always located to one side. Migraine headaches, although they may preferentially affect one side, will occasionally alternate sides. In-

Neurology

tracranial lesions may cause a unilateral headache if there is traction on blood vessels or dura, or may be diffuse if there is obstruction of cerebrospinal fluid pathways. Headaches in an elderly patient, particularly if unilateral, throbbing, or associated with neurological findings, may be due to cerebral vasculitis or temporal arteritis, and necessitate an urgent neurological referral.

E is for Exacerbating Factors. Exacerbating factors precipitate, aggravate, or worsen a headache. Such factors might include stress, certain foods, bright lights, etc.

A is for Alleviating Factors. Alleviating factors reduce or terminate the headache, and might include rest, medication, a dark room, etc.

R is for Radiation. This refers to spread after the onset of headache (i.e., where the headache progresses to).

N is for Nature. The nature or character of a headache will help classify it as vascular, tension, or traction/inflammatory. Vascular headaches tend to be throbbing in nature, tension headaches tend to be characterized by a bandlike sensation of pressure and traction/inflammatory headaches tend to be characterized by deep aching pressure, although it may also be stabbing, sharp, or dull.

I is for Intensity. Headaches should be rated on a scale of one to ten with ten being the worse and one the least. The patient should give a value for the average headache and the maximum headache, and relate the intensity of the headache to time from onset.

T is for Timing. A time intensity curve may help categorize the type of headache. Vascular headaches tend to build over several minutes to an hour. In the classic migraine vascular headache, the intensity builds to a maximum in 20-30 minutes. Tension headaches tend to increase slowly over hours to days. Traction/inflammatory headaches, depending on the type of pathology involved, may develop over a very short or very long period. The subarachnoid hemorrhage headache usually has a very acute onset over seconds, being described as a lightning bolt headache. Meningeal irritation headache may develop over days: A tumor headache may develop over weeks or months. The time of day or day of week of onset may be important. Headaches that occur early in the morning or awaken a person from sleep may be suggestive of a serious, possibly life threatening headache; however vascular cluster headaches commonly occur at night and awaken the patient from sleep. Tumor headaches tend to be worse with position change and are worse on awakening. Tension headaches tend to be worse on weekdays and are reduced on weekends, and usually intensify as the day progresses. Headaches due to caffeine withdrawal occur on weekends.

Clinical Evaluation

Most patients with headaches will have a normal physical and neurological examination. The examiner should pay attention to the head and neck, including inspection and palpation of the scalp, sinuses, and cervical spine for tenderness. The routine neurological examination should include an evaluation for any signs of neurological deficit, particularly focal neurological findings. A number of ancillary tests may be obtained in the evaluation of a headache patient, including blood count, chemistries, urinalysis, serology, and vasculitis screen. Radiographs of the sinuses, orbits, and temporal bone may be indicated. Clinical studies, such as electroencephalography, visual fields, and evoked potentials may also be helpful in identifying focal neurological abnormalities. Structural workups such as computerized axial tomography (CAT) or magnetic resonance imaging (MRI) may be indicated if neurological findings are present, there is a history of trauma, severe headache, or a traction/inflammatory headache. Lumbar puncture and spinal fluid analysis may be indicated if meningeal inflammation is suspected.

Muscle Contraction Headache

Tension or muscle contraction headaches account for over 40 to 50 percent of the headaches seen in a general neurology setting. The tension headache is usually described as an ache, tightness, pressure, crushing, or bandlike constriction, varying in intensity, frequency, and duration. These headaches often last days, and are commonly located in the frontal and suboccipital region. These headaches may be as severe or incapacitating as the vascular or migraine headache. The classic muscle contraction headache begins in late morning and progresses with intensity over the afternoon and evening and tends to be worse on weekdays. An intense muscle contraction headache often runs from the suboccipital region down to the shoulders. The most reliable features of muscle contraction headache are the sensation of tightness, pain in back of the neck, pain that intensifies as the day progresses, and pain and muscle contraction associated with anxiety or tension. Depression may also be a feature of this headache syndrome. Other medical conditions, such as cervical spondylosis or nocturnal chewing (bruxism), may contribute to muscle tension headaches. A number of chemical substrates may aggravate muscle tension such as bradykinin or prostaglandins, and have been implicated in the headache associated with systemic illness. Tension headache may result from occupational conditions, such as prolonged sitting over a desk, looking at video display terminals, or in combat maneuvering if the head was extended and rotated off axis while sustaining high Gs.

Treatment for tension and muscle contraction headaches should include elimination of possible stress factors, or other aggravating conditions. In the aviator, medication for headaches are not waiverable. Relaxation therapy such as biofeedback should be initiated. Medication for treat-

Neurology

ment of muscle contraction headaches include aspirin, acetaminophen, nonsteroidal anti-inflammatory drugs, and when indicated, muscle relaxants. Therapy with tricyclic antidepressant compounds such as amitriptyline, may also be helpful, particularly in mixed headaches. The compound Fiorinal, which contains aspirin, phenacetin, butalbital, and caffeine, may also be effective. Generally, no headache medicines are waived for flight activities.

Posttraumatic Headache

Ten to forty percent of patient's with minor head injury, particularly with scalp, skull, or sinus involvement, may have an associated headache. Pain may be steady, cap like, or superficial over the impact site, and may be aching or throbbing. Prominent neck injury may also be a factor. Headache after head injuries may be due to injury to the scalp vasculature or muscles, or stimulation of small nociceptive pain fibers. Posttraumatic headaches are often associated with imbalance, personality changes, or difficulty concentrating. These headaches usually resolve within several months. Persistent posttraumatic headaches may be the basis of compensation for accidents or medicolegal factors. Treatment generally includes analgesics and nonsteroidal anti-inflammatory medication. Resolution of any litigation is essential, as this inevitably contributes to the symptoms.

Vascular Headaches

Vascular headaches are associated with a cerebral blood vessel, either intracranial or extracranial. These headaches are often unilateral and are characteristically pounding or throbbing. Vascular headaches can be divided into nonmigraine vascular headaches and migraine vascular headaches.

Nonmigraine Vascular Headaches. Nonmigraine vascular headaches may be associated with a variety of medical, environmental, and physical conditions which may precipitate a throbbing unilateral headache. Medical conditions associated with headaches include cerebral vascular disease, hypertension, seizure, or endocrine dysfunction (hypopituitarism, Addison's disease, hypothyroidism, or pheochromocytoma). Environmental or physical factors may precipitate a vascular headache, such as hypoxia, anemia, or high altitude.

1. *Altitude Headache/Mountain Sickness.* Mountain sickness is often accompanied by severe pounding headache with associated nausea and dimness of vision. The altitude headache is usually a throbbing vascular headache often generalized and more evident over the frontal areas. It is unusual at altitudes below 8,000 feet, and almost universal feature over 12,000 feet in nonacclimatized individuals. It usually occurs in mountain climbers but may occur in those fly-

ing in unpressurized aircraft above 12,000 feet. The headache is not due to hypoxia alone as symptoms are not necessarily relieved by oxygen. The onset may be delayed six to 96 hours after arrival at higher altitudes. Altitude headache tends to be aggravated by movement, coughing, straining, or exertion. Evidence suggests that this may be due to an increase in intracranial pressure, based on the findings of papilledema, retinal hemorrhages, and elevated cerebrospinal fluid pressure or lumbar puncture. Treatment has included the use of mild analgesics to relieve the pain, and furosemide, acetazolamide, and dexamethasone to relieve intracranial hypertension. The cause of this headache may be aggravated by an underlying migraine condition.

2. *Effort/Exertional Headache.* Another nonmigrainous vascular headache which may be related to environmental or physical factors is the effort or exertional headache. This headache may occur in a variety of situations such as following intense physical exercise, coughing, or straining (during weight lifting or during sexual activity). The cough headache may be due to organic causes, such as intracranial tumors or the Chiari malformation, although the majority of effort headaches are due to benign conditions. If this headache is persistent or associated with vomiting, a structural workup and specialty consultation would be indicated.

Effort and exertional headaches have been observed in highly trained athletics and may be indistinguishable from a migraine headache. These individuals may aggravate their condition by becoming dehydrated, developing excessive heat production from muscle activity, or becoming hypoglycemic from sustained activity.

3. *Immersion Headache.* In naval aviation water survival training, a distinct effort headache, the immersion headache, is seen in susceptible individuals. This water immersion headache commonly occurs after the tower jump and underwater swim in flight gear and results in an explosive, throbbing, severe headache that usually occurs while underwater and reaches its maximum upon surfacing or shortly thereafter. Although the character suggests structural causes such as subarachnoid hemorrhage, this entity is usually benign. Immersion headache is precipitated by a specific situation and represents a variant of the exertional vascular headache. Immersion headaches following water survival training tend to be recurrent in repeated water survival situations, which are required for refresher training. Water immersion may be required in emergency egress, and aircrew and rescue swimmers may be required to perform this maneuver in tactical situations. Patients with immersion headaches are not physically qualified (NPQ) with no waiver recommended.

4. *Sexual Headache.* The sex associated headache occurs under situations of exertion and may result in a sudden excruciating vascular headache. Headaches usually occur at the time of mounting sexual arousal and also may be aggravated by anxiety, including that precipitated by il-

licit sexual activity with non spousal partners. Although they are usually not recurrent, these headaches may be incapacitating at the time.

5. *Food/Chemical Headache.* A variety of food and chemical substrates may precipitate vascular headaches. These substances are implicated in precipitating both migraine and non-migraine headaches. The non-migraine food associated headache is precipitated only by the substance, and is not otherwise characteristic of migraine. In the migraine food associated headache, classic migraine headache would occur in other situations besides those precipitated by food or chemicals. Chemical substances suspected of triggering vascular headaches include tyramine, phenylethylamine, monosodium glutamate (MSG), nitrites, and aspartame. Tyramine and phenylethylamine are in foods such as aged cheese, chocolate, yogurt, buttermilk, nuts, bananas, onions, avocados, figs, and red wines. Nitrites and nitrite compounds are used as food additives for purposes of preservation and to improve flavor and are in foods such as smoked fish, hot dogs, bacon, sausage, baloney, corn beef and pastrami. Monosodium glutamate is a common food additive, in oriental dishes, instant and canned soups, potato chip products, processed meat, gravies, TV dinners, and gourmet seasoning. Aspartame, an artificial sweetener used in drinks and other food substances has been implicated in precipitating headaches. Caffeine products have also been implicated in precipitating vascular headaches. Caffeine headaches are associated with excessive caffeine use (coke, coffee, tea, and colas) on weekdays and relative abstinence on weekends. Caffeine has a vasoconstrictive effect on blood vessels, and as it is metabolized and wears off, the blood vessels dilate, which may precipitate a vascular headache. By judiciously tapering off caffeine or reducing caffeine usage these headaches may be avoided. Medications implicated in vascular headache include reserpine, nitroglycerine, hydralazine, and oral contraceptives. Withdrawal from corticosteroid medication may precipitate headaches. Illicit drugs such as PCP, amphetamines, and cocaine may also trigger vascular headaches.

Migraine Headache Syndromes. Migrainous vascular headaches encompass a number of characteristic syndromes such as common migraine, classic migraine, cluster headache, and lower half (facial) migraine. Migraine syndromes associated with persistent neurologic deficits include the complicated migraine and acephalgic migraine. Vascular headaches of the migraine type are recurrent attacks of headaches, varying in intensity, frequency, and duration. They are commonly unilateral in onset, associated with anorexia, nausea and vomiting, and preceded by conspicuous sensory, motor, or mood disturbances. These characteristics are not necessarily present in each attack or in each patient. Features suggestive of migraine headaches include childhood onset of headache, cyclic vomiting or carsickness, a lifelong history, strong family history of similar hemicranial throbbing headaches, and response to ergot medication during the acute headache phase. The most characteristic feature of migraine is the classic prodrome, or aura that precedes the headache. Symptoms of the migraine aura include nonspecific nausea, vomiting,

anorexia, or a variety of transient neurologic symptoms (the migraine accompaniment). The incidence of migraine headache in the general population ranges between 3 and 20 percent. In one study of the young adult population, 20 percent of males and 50 percent of females described at least one severe headache associated with features of migraine.

1. *Common Migraine.* Common migraine accounts for 70 to 80 percent of migraine patients. The prodrome of common migraine tends to be vague and symptoms may last hours rather than the characteristic 20 to 30 minute aura that proceeds classic migraine. The headache is throbbing and usually unilateral, but may be bilateral. A family history of headache occurs in 65 to 90 percent of migraine patients.

2. *Classic Migraine.* Classic migraine accounts for 10 to 20 percent of migraine patients. The classic prodrome occurs 20-30 minutes prior to the onset of headache. This prodrome has a characteristic march, that is, the symptoms seem to build in intensity over a 20 to 30 minute period. The migraine accompaniment is the transient neurological event which accompanies the migraine. Neurological manifestations are often contralateral to the side of the headache. Such symptoms include visual, sensory, motor, or speech symptoms. Visual symptoms described include visual distortions, flickering lights, the classic fortification scotoma (teichopsia), described as jagged streaks of light resembling a sawtooth that shimmer and spread from the central vision to the periphery or from the peripheral to the central vision over 20 to 30 minutes. Other visual symptoms include a halo phenomenon (objects appear to have halos around them) or a shimmering heat wave appearance similar to heat radiating off hot pavement. Visual symptoms may be either monocular in the ocular (retinal) migraine, or bilateral (hemianopic visual fields) in the case of occipital (ophthalmic) migraine. Visual distortions may include alterations in color or size (micropsia or macropsia), tilting of the visual environment, multiple visual images (polyopia), or persistent visual images (allevesthesia). Visual symptoms are usually positive phenomenon, that is, they appear as light as opposed to dark phenomenon (absence of vision). The visual field defect may progress until tunnel vision and actual blindness occur. The symptoms march over a 20 to 30 minute period and are followed by a unilateral throbbing headache. Other migraine accompaniments (transient neurological symptoms), include sensory symptoms, such as the cheiro-oral paresthesia, transient hemiparesis, hemiplegia, dysarthria, or aphasia. These neurological symptoms generally proceed the headache; however, they may occur during or after the onset of headache. Photophobia may accompany the visual symptoms.

3. *Cluster Headache.* Another characteristic migraine syndrome is the cluster migraine. This accounts for two to five percent of migraine patients and has a strong male predominance (five or six to one, male to female), usually affecting the young adult. Cluster headaches are named because of their seasonal cluster and tendency to occur in the Spring and Fall. They occur

Neurology

approximately one to three times per day, last about 1 hour, recur over weeks to months and are followed by headache free intervals of months to years. There are two categories of cluster headaches; the episodic cluster headaches occur with long refractory headache free periods, while in chronic cluster, remissions (headache free periods) are less than 12 months. Cluster headaches are characteristically very severe and disabling and are often described as boring, searing, or stabbing. Characteristic associated symptoms include lacrimation, rhinorrhea, nasal stuffiness, and a partial Horner's syndrome (ptosis and miosis). Unlike common or classic migraine, where the patient seeks a quiet room and rest, the cluster patient will pace and walk around. Cluster headaches tend to occur in very perfectionist, obsessive-compulsive people. During the susceptible cluster period, the patient is sensitive to alcohol. Even very small doses of alcohol may precipitate a cluster attack. Only 15 to 30 percent of cluster patients have a family history of headaches, which is less than the usual 50 to 90 percent positive family history in common and classic migraine patients. The cluster headache, on initial presentation, will usually be referred for specialty consultation and structural workup to rule out intracranial pathology. Headaches tend to occur during periods of REM sleep and the patient often awakens from sleep with a severe headache. The mainstay of therapy is prophylactic treatment with Sansert (methysergide), lithium, ergotamine, and oxygen therapy. The aeromedical disposition of this condition is NPQ for duty involving flying (DIF) with no waiver for designated or nondesignated personnel. Generally these patients are NPQ for general military duty, due to the severe incapacitation associated with this headache.

4. *Complicated Migraine.* Neurological symptoms associated with migraine headaches are called migraine equivalents or migraine accompaniments. Neurological symptoms and signs that persist beyond the headache are called persistent migraine equivalents, and when they last over 24 hours after the headache, the condition is called complicated migraine. Persistent or complicated migraine equivalent syndromes include the hemiplegic migraine, basilar artery migraine, and ophthalmoplegic migraine. A number of other less common syndromes are the dysphrenic migraine, recurrent migrainous vertigo, abdominal migraine, cardiac migraine, and paroxysmal tachycardia. Hemiplegic migraine consists of persistent hemiparesis or hemiplegia following a headache and generally there is a strong family history. Basilar artery migraine is a migraine which is restricted to the posterior cerebral circulation. It usually presents in childhood and often there is a strong family history of headache. The headache is followed or preceded by symptoms of paresthesia, vertigo, ataxia, dysarthria, and occasionally transient loss of consciousness. Ophthalmoplegic migraine is a rare migraine syndrome, usually presenting in early childhood or young adolescence. The patient presents with pain followed by extraocular muscle palsy ipsilateral to the side of the headache. The cranial nerves affected are, in order of decreasing frequency of involvement, the Oculomotor (III), Abducens (VI), Trochlear (IV), and Trigeminal (V). The ophthalmoplegia may persist for several weeks. The pupil may not be

spared, with both sympathetic and parasympathetic pupil dysfunction. Generally there is no aura preceding the headache and because of the persistent neurological deficits, urgent specialty consultation and structural workup is indicated. History of complicated migraine in applicants is disqualifying for duty involving flying and if episodes were recurrent would be disqualifying for general duty.

5. *Acephalgic Migraine.* Approximately 20 percent of migraine patients do not experience headaches with their neurological symptoms. A migraine not associated with a headache is termed an acephalgic migraine. Migraines associated with neurological signs or symptoms beyond 24 hours, particularly when not associated with a headache, represent a complicated diagnostic challenge. On initial presentation these patients deserve a thorough workup for vasculitis and other forms of vascular disease such as atherosclerosis, embolic disease, etc. The most common migraine symptom to occur without headache are visual symptoms. When visual symptoms are confined to one eye (transient monocular blindness) this may mimic Amurosis Fugax due to vascular disease. Characteristic migraine visual phenomena are positive (flash or bright light) phenomena, whereas embolic or atheromatous disease affecting the retinal circulation tends to be a negative phenomenon (dark rather than light). Acephalgic migraine symptoms usually spread over 20 to 30 minutes, which is characteristic of migraine, while transient cerebral ischemic attacks (TIA) usually develop suddenly without a march of symptoms. A seizure disorder may march, but the seizure marches over seconds or minutes. Another common neurological symptom to occur without headache is paresthesia (transient sensory phenomenon). Other transient symptoms which may develop include speech difficulties (dysarthria), alexia, and recurrent vertigo. In children, acephalgic migraine may be manifested by acute confusional states, transient global amnesia, and dysphrenic states (psychic or mood migraine).

6. *Facial Migraine.* Facial migraine presents in the older population with jaw, neck (carotidynia), periorbital, or maxillary pain and is described as sharp icepick like jabs. Serious medical conditions, such as temporal arteritis or cerebral vascular insufficiency, must be differentiated from this condition. Temporal arteritis occurs in patients over 60 years of age who complain of jaw claudication, headache, fatigue, polymyalgia rheumatica, and have an elevated ESR and anemia on laboratory studies. The diagnosis is made by temporal artery biopsy. Temporal arteritis is treated with corticosteroids to prevent symptoms of blindness or neurological dysfunction. Carotidynia or lower half headache is usually diagnosed when the other studies fail to identify either ischemic vascular disease or temporal arteritis.

7. *Migraine Pathogenesis.* The theory behind migraine has traditionally involved vascular dysfunction. Presumably the neurological symptoms are due to vasoconstriction and the headache is due to vasodilatation resulting in stretching of pain sensitive fibers in the blood

Neurology

vessels. Other factors appear to be evident as well, however. Other phenomenon associated with migraine include a spreading depression of cortical activity, preceded by increased metabolic activity, which progresses across the cerebral cortex. Regional blood flow studies have indicated that in classic migraine, hypoperfusion (reduction in blood flow) occurs over the cerebral cortex and spreads at a rate of two to three millimeters per minute. This reduction in cortical flow may be a manifestation of neuronal dysfunction rather than a primary vascular problem. During the prodromal phase there is an increase in serotonin release from the platelets, which increases platelet adhesion and aggregation in the blood vessel. This is followed by a decrease in serotonin levels during the headache. Prostaglandins, platelet factor 4, and beta thromboglobulin, may also be increased, resulting in platelet emboli, possibly aggravated by vascular endothelial changes.

Treatment of Headaches

In general, if a precipitating factor can be found that aggravates or causes a headache, reducing or eliminating this factor may reduce or prevent the headache. A careful diet history and avoidance of provocative foods and substances may relieve headaches. Alcohol consumption should be tapered and caffeine history, if considered excessive, should be considered as a possible cause. Hormonal changes seem to be implicated, as migraines are more common in women. As estrogen levels fall, migraines may be precipitated. This accounts for the increase in migraines during the premenstrual period and a change in migraine character with menopause or hormonal manipulation. Pregnancy may also alter the migraine (favorably or unfavorably) and oral contraceptive use is implicated in increasing migraine severity. There is an increased likelihood of ischemic vascular event in a patient with a migraine history, oral contraceptive use and smoking.

Psychological factors such as stress, fatigue, and sleep deprivation should be avoided if possible. Physical factors known to precipitate headaches, such as exertion, exposure to smoke, solvents, or glare should be avoided.

Vascular migraine headaches are approached three ways: (1) symptomatic therapy for the infrequent headache, (2) prophylactic therapy if the headache occurs more than once or twice a week or is associated with severe incapacitating pain or neurological symptoms, and (3) abortive therapy if a classic prodromal phase occurs. Ergotamine remains the single most effective abortive agent and is administered either sublingually, intravenously, or rectally. Gastrointestinal motility is reduced during migraine attacks and delays absorption of orally administered medication. Prophylactic therapy includes beta blockers (propranolol), tricyclic antidepressants (amitriptyline or nortriptyline), and calcium channel blockers (nifedipine, diltiazem). Symptomatic therapy includes a variety of analgesic and anti-inflammatory medication. No headache medications are waived for flight status.

Aeromedical Disposition of Headache

Headache in any form is detrimental to safe flight as it may distract the flier from his duties. Migraine headaches in particular are worrisome because of the associated visual phenomenon which could interfere with collision avoidance, instrument interpretation, or depth perception. Associated symptoms of vertigo and paresthesias may also affect flying duties. Permanent visual field loss in migraine patients have been reported. A documented history of migraine headaches or of any recurrent or incapacitating headache would be disqualifying for duty involving flying in nondesignated personnel (aviation candidates). Following flight training, designated aviation personnel with less than two episodes a year of non disabling migraines would be NPQ with waiver recommended to service group III or Class II. Individuals with persistent neurological sequela with or without headache would require an extensive neurologic workup. If the evaluation found no organic pathology such as vascular disease, the designated flier would be NPQ and waivers would be considered on an individual basis. In general the patient would have to be symptom free for 12 months. All migraines waived would need automated visual fields submitted with their annual flight physical to detect any permanent visual field loss.

Seizures and Other Spells

Spells are defined as an abrupt (paroxysmal) disruption of a person's normal interaction with the environment. Spells in an aviator represent one of the most perplexing complaints a flight surgeon will encounter. The differential diagnosis of spells includes a variety of neurological, systemic, and psychiatric conditions. The usual presentation of the patient with a spell is the sudden onset of either alteration in mental status, loss of muscle tone and posture, or an excessive amount of motor activity. The neurological differential diagnosis of spells includes seizures, vascular events (TIA or stroke), atypical migraine (basilar artery migraine), syncope including convulsive syncope, paroxysmal sleep disorders (narcolepsy), intermittent movement disorders (paroxysmal choreoathetosis), myoclonus, essential startle response, fluctuating metabolic encephalopathies (hypoglycemia), and transient global amnesia. The psychiatric differential diagnosis of spells include anxiety attack, psychogenic fugue, catatonia, psychogenic amnesia, multiple personalities, depersonalization, episodic discontrol, and pseudoseizures.

Evaluation of Spells

The history is the most important part of the evaluation of a spell in an aviator. The quality of the history often depends on the time from the event to the time of the evaluation. The neurological examination is unremarkable, except during the event. The most likely diagnosis is derived from history, which is usually obtained from witnesses. Factors that should be evaluated

Neurology

include the time course of onset (i.e. whether it came on over seconds or minutes), and whether there were any preceding or precipitating factors, such as sleep deprivation, alcohol consumption, or hyperventilation. The duration of the event is important, as well as the time of recovery. The time of the event, such as its relationship to onset of sleep, time of day, or meals, may also be important. Muscle tone and position prior to the event should be established. The level of arousal at the beginning, during, and after the event are important clues to the etiology of the spell. The overall appearance at the time of the event (pallor, cyanosis) as well as the type of injuries (bitten tongue, bruises) sustained should also be investigated.

Seizures and Epilepsy

A seizure is an uninhibited sudden discharge from a group of neurons resulting in epileptic activity (neuronal storm or excessive paroxysmal neuronal discharge). Epilepsy is derived from the Greek word meaning "to seize or lay hold of." A seizure is a single episode of excessive neuronal discharge and epilepsy is a propensity for recurrent seizures. It is estimated that two to five percent of the general population will have one epileptic seizure during their life and that recurrence could be expected in approximately half of these people. It is estimated that 70,000 new cases of epilepsy are diagnosed each year. The prevalence of epilepsy in the U.S. population is approximately four million. The implications in the aviation environment are substantial and accurate diagnosis is crucial to aeromedical disposition.

Seizures are classified according to 1) type or 2) etiology (cause) of the seizure. The seizure types are either (1) partial (focal) seizures, (2) primary generalized seizures, or (3) partial seizures with secondary generalization. Primary generalized seizures always involve an alteration of consciousness and include absence (petit mal), myoclonic seizures, clonic seizures, tonic clonic seizures, and atonic seizures. Partial seizures are seizures that originate in a focal area of the brain and may or may not propagate to other areas. Simple partial seizures do not alter consciousness. Complex partial seizures, which result in altered consciousness may begin as a simple partial seizure, or start as a complex partial seizure. A complex partial seizure may or may not progress into a generalized tonic clonic seizure.

Depending on the area of the brain involved, the partial seizure may begin with motor, sensory, autonomic, or psychic phenomenon. Since partial seizures may not always progress to tonic clonic movement or alteration in consciousness, this condition represents one of the most elusive diagnoses in neurology and is frequently misdiagnosed. One of the most helpful points in the partial seizure history is the stereotypical premonitory epileptic event, the aura. The patient will often describe the aura as a virtually identical sensation every time. The typical progression of simple partial to complex partial to secondary generalized seizure is as follows: 1) an aura, 2) a cry, 3) a

fall, 4) the fit, which starts as tonic activity then progresses to clonic activity, and finally 5) incontinence. The seizure aura is one of the most important items in the history of partial seizure disorders. Aura means "breeze" in Greek, and literally is like the wind blowing over the patient prior to his seizure. It is often described as a premonition or vague sensation of strangeness. Depending on the area of brain involved, a variety of experiences may be encountered. The patient may feel a vague epigastric sensation, such as an empty, sick, nauseated feeling rising up out of the stomach into the mouth. A variety of affective symptoms have been described including fear, pleasure, depression, eroticism, and rarely anger. The patient may have a feeling of familiarity (de-ja-vu), or a feeling of unfamiliarity or depersonalization (jamais vu).

A variety of hallucinations may also be experienced. Sensations may be quite vivid, and like all partial seizure auras are usually very stereotypic. Auras may be described as 1) formed visual hallucinations, 2) auditory hallucinations, such as music, (not voices), 3) olfactory hallucinations (unpleasant smells such as burning), or 4) gustatory sensations (metallic taste). Sensory aura phenomenon include tingling, numbness, electricity, or heat. Visual illusions may also be encountered, usually distortions in shape or size of objects. The aura may or may not progress to an alteration in consciousness as the epileptic discharge progresses through adjacent areas of the brain.

Another characteristic feature of the partial complex seizure is the semipurposeful automatism. Automatisms are more or less coordinated, semipurposeful, involuntary, motor activity. They occur during the altered consciousness, during or after the seizure, and are frequently followed by amnesia of the event. Some examples of automatism include chewing, swallowing, repetitive vocalization, humming, singing, laughter, mimickery, non-directed anger, blinking, gesturing, wandering, fumbling, fidgeting, or non-directed genital activity.

If a seizure generalizes, there will be an initial tonic phase, which starts as a transient flexion of trunk and extremities, followed by a 10 to 30 second period of extension of the head and neck, axial rigidity, clamping of the jaws, and transient respiratory arrest. Shortly thereafter the clonic phase ensues with 30 to 60 seconds of convulsive activity, which most people would recognize as a seizure. There may be labored breathing and salivating. As the clonic phase progresses, there is a decrease in frequency and an increase in amplitude of convulsive movements. The flaccid phase may result in urinary or fecal incontinence. This flaccid phase may last two to 30 minutes and may be asymmetric (Todd's paralysis) in recovery. The ictal (tonic-clonic) phase of a seizure may be as short as several seconds to as long as eight minutes, but usually lasts one to two minutes.

The postictal phase, heralded by the patient's gradual return to consciousness, may last as short as several seconds to as long as 30-60 minutes and averages about five to 15 minutes. It is this

Neurology

postictal phase (postictal confusion) which is the most helpful historical clue in establishing whether or not someone had a seizure. In general, a person who has lost consciousness because of syncope, even if observed to have convulsive syncopal movements, would recover consciousness fairly quickly upon return of normal blood pressure. The patient who had a true epileptic event would regain their normal level of awareness over a much longer period of time. Confusion arises when a syncopal patient sustains a head injury and is dazed and confused from the injury. It is absolutely crucial to obtain the history from observers actually present at the time to establish the period of recovery or postictal confusion. Absence (petit mal) seizures are the one exception to postictal confusion in generalized seizures. Absence spells occur during adolescence, last less than 10 seconds, may exhibit a variety of automatisms, but have no substantial postictal confusion. Absence seizures may occur several hundred times a day and commonly present as poor school performance. They may progress to generalized tonic-clonic seizures in adulthood.

Etiology of Seizures. Seizures may be due to vascular, infectious, neoplastic, traumatic, degenerative, metabolic, toxic, or idiopathic causes. The idiopathic category accounts for 40 to 50 percent of all seizures in adults. In the early years, birth trauma, metabolic, infectious, and idiopathic causes predominate, in the mid adult age group trauma, tumor and idiopathic causes are common; and in the older age group tumor and vascular disease are implicated. Drug induced seizures are usually seen with medications parenterally administered in high doses in a patient with a seizure predisposition or exhibiting some altered metabolism which affects drug clearance (liver or kidney disease). Antibiotics (particularly IV penicillin), antihypoglycemics, antiarrhythmics, antidepressants, (amitriptyline and imipramine), anticholinergics, stimulants (amphetamine), aminophyllin, and lithium have been implicated in seizures. Alcohol related seizures that occur in the acute phase of alcohol consumption are due to the toxic effects of alcohol. Alcohol withdrawal seizures occur 24 to 48 hours after ceasing alcohol consumption. Seizures occurring three to eight days following cessation, are suggestive of delirium tremens.

Posttraumatic epilepsy (PTE) is divided into early epilepsy, which occurs in the first week, and late epilepsy, which develops after the first week. Posttraumatic epilepsy is significantly related to the degree of brain injury. In penetrating (missile injuries) the incidence of posttraumatic epilepsy is well over 35 percent, whereas in nonpenetrating (non missile injury) the incidence is usually less than five percent. Posttraumatic epilepsy usually occurs within the first several years after the traumatic event. Approximately 80 percent of patients who develop posttraumatic epilepsy will do so within two years of the trauma.

Factors influencing the development of late posttraumatic epilepsy include an early post-traumatic seizure, depressed skull fracture, intracranial hematoma, dural penetration, focal neurological deficit, and posttraumatic amnesia over 24 hours with the presence of a skull frac-

ture or hematoma. Post traumatic anterograde amnesia (PTA) has been implicated as *a* risk factor for posttraumatic epilepsy. In the absence of a skull fracture or hematoma, amnesia longer than 24 hours is associated with an incidence of epilepsy of only 1.5 percent while amnesia of less than 24 hours has an incidence of epilepsy of less than one percent, implying amnesia without other risk factors may not be as significant a factor in the development of posttraumatic epilepsy as was previously thought.

Pseudoseizures. Pseudoseizures, also called psychogenic seizures or nonepileptic seizures, are a type of behavior which resembles an epileptic event but are voluntary and not due to organic pathology. They may resemble organic seizures. As there are no absolute criteria to make the diagnosis; pseudoseizures are often a diagnosis of exclusion, requiring extensive testing at a specialty center. To make matters worse 10 to 30 percent of patients with pseudoseizures also have organic seizures. It is estimated that 5 to 15 percent of patients with refractory seizures, not controlled with medication, are actually having pseudoseizures.

There are several factors that are helpful in distinguishing an organic seizure from a nonepileptic seizure. Pseudoseizures are generally not stereotypic and usually have bizarre behavior and extreme variation. There may be a family history or past medical history of psychiatric disease. The ictal phase of an epileptic seizure is usually less than 100 seconds while the ictal phase in pseudoseizures is usually over 200 seconds. Eye flutter or twitching eyelids occur during the ictal phase of an epileptic seizure and is usually not seen in nonepileptic seizures. Epileptic seizures are more common in men while pseudoseizures are more common in women in the 15 to 35 year old age group. Pelvic thrust movements are not usually seen in epileptic seizures but are common in pseudoseizures. Generally there is not vocalization except at the very beginning of an epileptic seizure (the cry). Vocalization or interaction with the observer may occur throughout the course of a pseudoseizure. In epileptic seizures there is usually minimal resistance to eye opening, in the pseudoseizure there is marked resistance to eye opening and the eyes have a tendency to look away from the observer no matter what direction the observer approaches the patient from. Any injury, such as tongue biting or loss of muscle tone resulting in injury, is uncommon in a pseudoseizure, but may be seen in true epileptic seizures. A prolactin level drawn within 20 minutes of a seizure would be markedly elevated (above 1000MU/L) in a generalized tonic clonic seizure, and will be above 500MU/L in a partial complex seizure, but in a pseudoseizure will be within normal limits. In most cases patients presenting with recurrent seizures suspicious of pseudoseizures require video monitoring and referral to a seizure center.

Aeromedical disposition of Seizure Patients. Any seizure or epileptic convulsion, with the exception of a single simple febrile seizure occurring before age 5 years old is considered disqualifying for aviation duty in nondesignated and designated aviation personnel.

Assessment and Treatment. For Assessment and treatment of seizures see: Appendix 7-D, *Approach to New Onset Seizures*, and Appendix 7-E, *Approach to Status Epilepticus*.

Syncope

Syncope is in the differential diagnosis of spells (abrupt alteration in the normal interaction with the environment). Syncope is the sudden transient loss of consciousness and muscle tone due to a sudden impairment of brain metabolism due to a reduction in blood flow, oxygen, or energy substrate to the brain. In most cases the distinction between syncope and seizures is made from the history. Classically, the syncopal patient was in an upright posture and often had a presyncopal sensation (feeling of lightheadedness or loss of vision) prior to the event. Upon losing consciousness, the syncopal patient is flaccid, pale, and sweating and has usually not sustained any injury because the loss of muscle tone was gradual enough to allow the patient to reach the ground without serious injury. The tongue has usually not been bitten. Incontinence can be seen with either syncope or seizure and is usually not diagnostic. Difficulty arises when the syncopal event is associated with tonic-clonic muscle activity (anoxic myoclonic jerks). Myoclonic jerks, seen in syncope, are termed convulsive syncope or anoxic myoclonus, and are likely to occur if loss of consciousness exceeds 15 to 20 seconds. The key to differentiating syncope from a seizure is the recovery of consciousness. Following a fainting spell, blood pressure rapidly returns, and consciousness returns to normal without any period of postictal confusion or disorientation in the syncopal patient, unless the patient sustained a head injury from the fall.

Classification of Syncope. Syncope can be divided into one of four categories. Reflex syncope, called vagal syncope in older literature is the most common type of syncope in the young population. Respiratory syncope, cardiac syncope, and areflexic (paralytic) syncope make up the other categories.

In reflex syncope a variety of situations may be implicated, such as emotion, or anxiety, pain, venipuncture, prostate exam, oculovagal pressure, micturition, defecation, or postural change. Situational reflex syncope may result from an increased or hypersensitive reflex mechanism.

Reflex Syncope is subdivided into vasodepressor or cardioinhibitory syncope. Vasodepressor syncope is due to peripheral vasodilatation of the muscle bed. Cardioinhibitory syncope is due to an increased vagal tone, which slows the heart rate. In vasodepressor syncope the patient looks pale and feels cold, due to vasoconstriction of the skin and the presence of sweat. There are four physiological phases of vasodepressor syncope. In the presyncopal phase there is a gradual fall in blood pressure and cardiac output. In the compensatory phase there is a gradual increase in heart rate and peripheral vascular resistance in response to the falling blood pressure and cardiac

output. Finally in the syncope phase there is a precipitous drop in peripheral vascular resistance due to vasodilatation of the skeletal muscle bed, resulting in a drop in a blood pressure and heart rate. In the recovery phase, blood pressure, heart rate, and cardiac output increase and there is a gradual rise of peripheral vascular resistance. Although a variety of precipitating events such as change in posture, diminished blood volume, anoxia, or fear may trigger vasodepressor syncope, they all progress through these phases. Some situational reflex syncopes such as micturition and carotid sinus syncope may result from vagal slowing due to a cardioinhibitory response. Vagal (cardioinhibitory) syncope is less common than vasodepressor syncope and may result in syncope even in the recumbent position. Cardioinhibitory syncope has been implicated in cardiac arrest in athletes and sudden infant death in children.

The next category, respiratory syncope, occurs in a variety of situations, such as coughing, playing wind instruments, or during weight lifting. Respiratory syncope may result from an increase in intrathoracic pressure (over 250 to 300 mm Hg) resulting in an increase in cerebral venous pressure, subsequent elevation in intracranial pressure, and reduced cerebral perfusion pressure. Increased intrathoracic pressure may also cause impaired venous return to the heart reducing cardiac output. A cardioinhibitory mechanism may result from a transient rise in blood pressure resulting in a carotid sinus response causing vagal slowing of the heart, or an overactive pulmonary stretch receptors in the lung wall, causing a pulmonary stretch reflex, resulting in cardiac slowing. Cough syncope, called laryngeal vertigo in older literature, occurs in obese males with chronic bronchitis and emphysema and commonly results in a baroreceptor response and vagal slowing. The valsalva maneuver causes less elevation in the atrial blood pressure, however, intrathoracic pressure is sustained for a longer period of time and may result in a hyperactive pulmonary stretch reflex and vagal slowing.

The next category is cardiac syncope, which is due to a reduction in blood flow due either to a dysrhythmia or outflow obstruction. Examples of cardiac syncope include the Stokes Adams' attack (complete heart block), the sinoatrial node dysfunction (sick sinus syndrome), and the tachycardia bradycardia syndrome, seen in paroxysmal atrial tachycardia and paroxysmal supraventricular tachycardia. Syncope occurring during exercise or exertion, may be due to ventricular outflow obstruction from aortic stenosis, or underlying cardiac disease, such as cardiomyopathy.

The final category of syncope is areflexic (paralytic) syncope. Unlike reflex syncope, where a hypersensitive reflex is responsible for the drop in blood pressure, in areflexic syncope there is a loss of the automatic reflex arch which results in loss of the normal compensatory mechanisms which the body uses in controlling blood pressure. In areflexic syncope the skin remains warm, sweating is present, and the heart rate remains unchanged. In vasovagal syncope the skin initially

Neurology

appears pale, cold, and the heart rate usually drops. The reflex failure in areflexic syncope may be due to preganglionic, ganglionic, or post ganglionic sympathetic fiber damage. Preganglionic damage occurs in Tabes Dorsalis, ganglionic involvement occurs in Shy Drager syndrome and spinal cord injury, and post ganglionic areflexic syncope may occur following sensory neuropathy. With dysautonomic or areflexic syncope, patients are more susceptible to dehydration or drug affects. Drugs which may precipitate syncope include oral diuretics, antihistamines, tricyclic antidepressants, benzodiazine, ganglionic blockers, barbiturates, and antiparkinson medication.

Evaluation of Syncopal Patient. The goals of the syncope evaluation are: (1) Establish a precipitating event or situation, (2) determine any predisposing factors, (3) identify a deficiency in the normal compensatory mechanism, and (4) identify hypersensitive physiological responses. Factors which may predispose or contribute to syncope include inadequate diet, dehydration, fatigue, sleep deprivation, emotional stress, anxiety, underlying infection, excessive caffeine use, alcohol intake, and self medication. These factors should be thoroughly explored in aviation personnel, as most flyers will fall into the category of reflex syncope.

A format for evaluating the syncopal patient is enclosed in Appendix 7-F and includes testing designed to stimulate hypersensitive cardioinhibitory reflexes or detect deficient compensatory responses. In addition to the physical examination and the syncope test battery, laboratory workup might include a complete blood count, electrolytes, glucose tolerance test, graded exercise test, 24-hour holter monitor, echocardiography, and electroencephalography, depending on the most likely etiology.

Aeromedical Disposition of Syncopal Patients. Syncope is a relatively common complaint and in medically prescreened aviation personnel, most likely represents a benign process. Every effort should be made to establish a predisposed factor or a specific situation which contributed to the syncopal event. If a benign etiology is established and an underlying predisposing factor eliminated, then an aviator could be returned to flight status. In general, the reflex syncope is the most benign of the group, and cardiac and areflexic syncope are more serious. In designated personnel with recurrent syncope or syncope due to serious conditions, waivers might be considered on an individual basis, generally by referral to a Special Board of Flight Surgeons. Respiratory syncope may pose a threat to aviation safety, particularly in the tactical community where the anti G straining maneuver would necessitate an increase in intrathoracic pressure. If syncope is reproduced in an aviator during provocative syncope evaluation testing, this usually indicates a hypersensitive physiological response, and may indicate a predilection for recurrent syncope. Non-designated aviation personnel would be NPQ with no waiver, and designated personnel would be considered for a waiver only for nontactical aircraft in Service Group III or Class II personnel. The waived flyer should be cautioned to avoid any precipitating event.

Vertigo and Disequilibrium

Introduction

Patients with dizziness, vertigo, and disequilibrium may present to the flight surgeon with a variety of complaints or symptoms. Patients with vertigo may complain of dizziness, lightheadedness, unsteadiness, imbalance, spinning, floating, and swaying, just to name a few. The history is one of the most important aspects of the dizziness evaluation. Based on the history, dizziness should be classified into one of four types:

1. True vertigo - definite rotational sense.
2. Presyncope/syncope - sensation of impending faint or loss of consciousness.
3. Disequilibrium - sensation of unsteadiness or loss of balance.
4. Ill defined lightheadedness not otherwise classified.

By classifying the patient into one of these four categories, a more pertinent differential diagnosis is established. This is further augmented by the examination and diagnostic tests and guides therapy and medical treatment. Despite a thorough evaluation, an identifiable etiology may not be established. The sensation of vertigo and disequilibrium may be due to:

1. Peripheral vestibular dysfunction.
2. Central vestibular dysfunction.
3. Systemic dysfunction.
4. Nonorganic (psychiatric) dysfunction.

The characteristics and pattern of the vertiginous sensation should be thoroughly evaluated. The rapidity of onset and duration of vertigo, should be established. Factors which make the vertigo worse, such as positional changes, or whether the eyes are open or closed may also be helpful. Associated auditory symptoms such as tinnitus, ear fullness, pain, or hearing loss usually indicate peripheral vestibular dysfunction. Signs of central neurological dysfunction include diplopia, ataxia, dysphagia, dysphonia, or sensory or motor complaints. Important historical factors include prior head injury, recent viral infection, toxic exposure, or medication use.

Physiological Substrates of Vertigo

Spatial orientation is accomplished by utilizing sensory information from the visual, vestibular, and somatosensory systems, which are processed in the brain stem, then finally integrated into the cortical perception system. Disruption or altered processing of signals from the visual, vestibular,

Neurology

or somatosensory system may cause disorientation or vertigo. For example, a patient who has undergone cataract extraction may have distortion of his visual system and may be profoundly disoriented. A patient with a peripheral neuropathy may have a diminished sense of proprioceptive input from joints and muscles, resulting in substantial disequilibrium, particularly in a low light situation, where the reduction in visual input further degrades orientation.

Vertigo is defined as a hallucination of movement or erroneous perception of self or object motion. It is usually an unpleasant sensation due to distortion of static gravitational orientation perceived by the cortical spatial perceptual system. This erroneous perception of motion of person or environment may be linear or angular (rotatory). This section will focus primarily on the vestibular system and its relationship to vertigo and disequilibrium. The orientation function of the vestibular system is twofold: 1) maintenance of postural tone and 2) stability of visual-ocular position. The utricle and saccule are linear accelerometers detecting linear motion in the front to back (transverse) plane and side to side (sagittal) plane, respectively. These linear motion detectors provide input to the postural maintenance section of the vestibular system. This vestibulospinal system is responsible for maintaining an erect posture and counteracting the effects of gravity on body position. The angular accelerometers, the semicircular canals, provide input to the oculomotor system, which maintains ocular stability, particularly during movement. Linear accelerometers are found in such primitive creatures as the jellyfish, and angular accelerometers are found in such primitive creatures as the octopus. As animals evolved evolutionarily, these linear and angular accelerometers became more sophisticated.

Vertigo and disequilibrium may result from a mismatch of sensory signals from either the static or dynamic spatial orientation systems. There is overlap among the visual, vestibular, and somatosensory signals that are centrally processed. Central compensatory mechanisms enable deficiencies in one area to be overcome by other intact sensory systems. As a result of this reprocessing of signals by the central nervous system, symptoms of peripheral labyrinth dysfunction will eventually recover. Symptoms of central nervous system dysfunction, although usually milder, tend to persist over time. The intensity of the vertiginous or disequilibrium sensation is a function of the degree of mismatch between functioning and dysfunctioning or nonfunctioning sensory systems. Because of the interaction between the various central processing systems, other symptoms besides vertigo may be experienced. Vertigo itself is a symptom that is perceived at a higher cortical level. Vertigo may be due to excessive physiological stimulation or pathological dysfunction.

Gait imbalance or ataxia results from inappropriate or abnormal signals from the vestibulospinal system. Nausea and vomiting may occur from activation of the chemoreceptor trigger zone (medullary vomiting center). Nystagmus (rhythmic jerking eye movements) may be

observed with dysfunction of the vestibulo-ocular brain stem processing center or peripheral vestibular system.

Physiological Vertigo Syndromes

In physiological vertigo the sense of disequilibrium is due to physiological excess of visual, vestibular, or somatosensory signals which cannot be compensated for by the other systems. In pathological vertigo there is an abnormal sensory signal (from the sensors) or abnormal signal processing (by the central nervous system). Examples of physiological vertigo (due to inappropriate stimulation) include motion sickness, space sickness, height vertigo, visual vertigo, somatosensory vertigo, head extension vertigo, and bending over vertigo. These physiological vertigo states have significance in aerospace medicine, particularly the type of motion sickness seen in neophyte fliers - airsickness.

Motion Sickness

Motion sickness is due to sensory conflict. We make several assumptions of our visual world. With a head movement in one direction, the visual scene should move in the opposite direction. As we have evolved in a one G horizontal plane, we are accustomed to gravitational movements in the horizontal plane only, not the vertical plane. The angular accelerometers (semicircular canals) sense turns and the linear accelerometers (otolith organs) detect to and fro and side-to-side motion. Motion sickness appears to be worse at frequencies of vibration or oscillation from 0.2 to 0.6 Hz. Although infants under age two are quite resistant to motion sickness, it becomes a problem particularly in the adolescent and young adult. Motion sickness is worsened by removing or altering the surrounding visual environment. Motion sickness is worse in aircrew, particularly Naval Flight Officers, who stare at their instruments, when the outside reference horizon is lost (instrument flight conditions), or during rapid changes in aircraft attitudes. Motion sickness is overcome by central adaptation and habituation. This may be augmented by reducing anxiety (relaxation techniques, reducing life stress), keeping well hydrated, getting a good night's sleep, engaging in regular exercise, eating regular meals, and avoiding tobacco, caffeine, and alcohol. In aviation personnel who wear contact lens it is important to continue to wear the same contacts and not alternate between contact lenses and glasses because this will change the vestibulo-ocular reflex and make one more prone to visual conflict. In aviators who only wear their glasses at night, they may develop motion sickness and disorientation for the same reason. In neophyte aviators pharmacologic intervention may accelerate this adaptation. One of the most effective medications is scopadex (25 mg of scopolamine hydrobromide with 5 mg of dexamphetamine). Another effective medication is promethazine (25 mg) with ephedrine (25 mg.). Pharmacological intervention is a temporizing measure and a positive effect should be seen within

Neurology

three to five doses, and should be used in conjunction with continued flight training to be maximally effective. An airsickness desensitization program is available at NAMI which involves a potent vestibular stimulus, cross coupled coriolis effect. Balance practice may enhance adaptation to visual vestibular conflict. In the balance practice, the patient stands in the tandem position with one foot in front of the other with the head extended (as if looking at the ceiling), hands placed across the shoulders and the eyes closed. Enhancement of this test can be performed by standing on one foot, which is extremely difficult. This test enables the person to become habituated to sensory stimuli without visual input. This position places the linear accelerometer (otolith organs) outside of their normal range of sensitivity and may allow the patient to adapt to sensory conflict. Inflight techniques for managing airsickness include avoiding hyperventilation, establishing a reference horizon, and going on 100 percent oxygen. The most important consideration with airsickness in flight is to maintain flight safety (aviate, see and avoid other aircraft) and establish crew coordination.

Space Motion Sickness

Another type of physiological vertigo is space sickness. Space motion sickness (SMS) includes headache, malaise, lethargy, stomach awareness, nausea, and vomiting due to increased sensitivity to motion and head movements. Space sickness probably results from vestibular mismatch between the otolith organs and the semicircular canals, or the side to side difference in otolith input in the microgravity environment. Space sickness occurred in 35 percent of Apollo astronauts, 60 percent Skylab crew, and has plagued 67 percent of the Space Shuttle missions, where over 50 percent have moderate or severe symptoms. It seems to occur when astronauts engage in free movement, unlike the restrained position in the space capsule of the Mercury and Gemini missions. It begins 15 minutes to six hours after launch, but may be delayed up to 48 hours, with peak severity occurring two to four days into the flight. Habituation occurs within three to five days. On short duration missions, SMS may cause significant incapacitation and thus compromise mission effectiveness. SMS has had an operational impact, delaying extravehicular activity (EVA) until after the third postlaunch day, and has limited minimum duration flights in the space shuttle to three days, to ensure that the crew is recovered prior to reentry and landing.

Height Vertigo

Height vertigo is a type of physiological vertigo due to visually induced instability and occurs when the observer is a certain height above the ground where stationary objects in the visual field are far off in the distance. Height vertigo usually occurs above three meters and reaches its maximum at 20 meters of height. Ordinarily, the body has a normal amount of body sway which is constantly being corrected for. The further away a stationary object is, the greater the degree of

body sway must occur before a movement is detected and compensated for. This is the physiological basis for height vertigo which over time may progressively worsen and become a fear of heights with its associated psychological reactions. Height vertigo is worsened by standing, staring at moving objects overhead such as clouds, and by looking through binoculars which reduce the peripheral field. Height vertigo is reduced by sitting or lying down or looking at a stationary object which is on the same plane and close to the observer.

Visual Vertigo

Another type of physiological vertigo is visual vertigo, also called optic kinetic motion sickness, or pseudo-coriolis vertigo. This is induced by viewing moving objects and responding to the perceived motion with a change in posture. For example, while viewing a movie of an automobile, airplane or other type of movement, the viewer characteristically turns their body in the direction of the visual stimulus in an attempt to accomplish postural stability. This pseudo-coriolis effect is quite potent and can be every bit as disorienting as vestibular vertigo.

Somatosensory Vertigo

Somatosensory vertigo or arthrokinetic vertigo, is due to an illusion of movement caused by muscle or tendon input over a certain area. This is commonly referred to as seat of the pants vertigo and may occur in an aircraft in a turn where the gravity vector is increased or redirected off the normal gravitational plane resulting in the "leans". False input from the otoliths may also contribute to this illusion.

Physiological Positional Vertigo

Two other types of physiological vertigo are head extension vertigo and bending over vertigo. Positional physiological vertigo may be encountered when the linear accelerometers (otolith organs) are pushed beyond their optimal functioning range with the neck extended or flexed, and are worsened by the removal or alteration of visual input (closing eyes or looking up at moving clouds).

Psychogenic Vertigo

Psychogenic vertigo may result from hyperventilation or occur in a patient with known psychiatric disease. A patient with psychogenic vertigo may have a subjective complaint of severe vertigo without associated nystagmus or other physical findings. Severely incapacitating vertigo may be seen in anxiety attacks or in severe height vertigo (acrophobia). Psychogenic vertigo

would be treated based on the underlying psychiatric diagnosis. Psychotherapy and desensitization procedures are often useful. A diagnosis of psychogenic vertigo presumes that no physical findings substantiate an organic cause for the vertigo symptoms.

Pathological Vertigo Syndromes

Pathological vertigo results from abnormal sensory input or abnormal central processing. Pathologic vertigo may be either visual, somatosensory, or vestibular. Pathological visual vertigo may occur in patients following cataract extraction, where high plus glasses used to correct for the loss of the lens cause a significant alteration in the vestibular ocular reflex resulting in ocular vertigo. This may also be seen in patients who have a substantial difference in visual acuity between the two eyes. Somatosensory pathological vertigo may occur in patients with peripheral neuropathies. The loss of sensory input from the muscle spindles and tendon organs reduce the amount of information that tells the patient from a proprioceptive standpoint where they are relative to their environment. Sensory deficits are additive, so a patient with visual dysfunction and peripheral neuropathy may have more disequilibrium than either alone. Pathological vestibular vertigo can be due to either peripheral labyrinth dysfunction, systemic derangement (such as metabolic, endocrine, or circulatory abnormalities), or central vestibular dysfunction.

True vertigo can be divided into one of four clinical syndromes. The first syndrome is paroxysmal rotational vertigo which occurs in definite attacks. The second type is sustained rotational vertigo, lasting a considerable period and not occurring in discrete attacks. The first two categories are not positionally induced or aggravated. The third type is positional vertigo, (i.e., induced or aggravated by positional changes). The fourth category is linear vertigo, either a side-to-side or to and fro disequilibrium.

Paroxysmal Nonpositional Vertigo

Rotational vertigo attacks in children and young adults are most likely benign paroxysmal vertigo of childhood or basilar artery migraine. In adults, late life migraine equivalents (vertebrobasilar migraine) or basilar artery insufficiency (in older people with vascular disease) should be considered. Other conditions which may also occur in acute discrete attacks are Meniere's disease, familial periodic vertigo, and rarely, vestibular epilepsy.

Sustained Nonpositional Vertigo

Sustained rotational episodes may be seen in Meniere's disease, acute vestibular neuronitis, and vestibular nerve lesions (acoustic neuroma), and brain stem lesions.

Positional Vertigo

Positional vertigo may occur in brief attacks when in provocative positions, or may persist after the position change. Positional vertigo most commonly is due to benign paroxysmal positional vertigo (BPPV) but may also occur in perilymph fistula, positional alcohol vertigo and nystagmus, various toxic conditions, basilar artery insufficiency, and central nervous system lesions of the vestibular nucleus or midline cerebellar region.

Linear Vertigo

Linear vertigo, resulting in disequilibrium and postural imbalance, may be seen in peripheral or central nervous system pathology. Lateral (side- to-side) imbalance and disequilibrium may be seen in either otolith organ dysfunction, or disease of the vestibular nucleus or midline cerebellum, (lateral medullary syndrome due to vertebral artery occlusion). The fore- and-aft postural imbalance occurs in upper brain stem dysfunction due to a variety of pathological conditions (degenerative, neoplastic, toxic, and vascular disease).

Specific Vertigo Syndromes

Benign Paroxysmal Positional Vertigo. One of the most common peripheral vestibular syndromes is benign paroxysmal positional vertigo (BPPV), which may occur at any age. The characteristic history is of brief episodes of positionally induced vertigo, particularly with rapid changes in position such as getting out of bed. The true vertigo or rotational sensation usually lasts less than one minute; however, a nonspecific dizziness, often described as a swimming sensation or disequilibrium, may last hours to days. Although BPPV may remit spontaneously, fully one third of patients have recurrent symptoms for more than one year.

Vestibular Neuronitis. Acute unilateral labyrinth dysfunction (vestibular neuritis or neuronitis) presents with the acute onset of severe vertigo with associated positional imbalance, nausea, and nystagmus. This syndrome is different from benign paroxysmal vertigo in that it has a much more prolonged course, is usually more severe, and is not positionally induced, as is benign positional vertigo. Vestibular neuronitis often occurs in epidemics, is often due to a viral etiology, and may be a variant of Bell's palsy of the vestibular nerve. This syndrome may involve the semicircular canals or otolith organs, and depending on the area affected, may result in linear or rotational vertigo. In vestibular neuronitis, due to the reduced signal from the affected side, the nystagmus fast phase is directed away from the affected side. There are two sensations of body motion. The environment appears to move away from the side of lesion and the postural reaction which attempts to compensate for this, causes past pointing and falling toward the side of the lesion.

Neurology

Viruses known to affect the auditory, vestibular, and facial nerves include mumps, measles, infectious mononucleosis, and herpes zoster. Herpes zoster can present with ear pain, facial palsy, deafness, and vertigo and is diagnosed if vesicles are present in the external ear (Ramsey Hunt syndrome). Management and therapy for acute unilateral labyrinth dysfunction (vestibular neuritis) is dependent on the clinical stage of the symptoms. In the first three days, when there is a significant amount of nausea and vertigo, it is recommended that the patient follow a regimen of strict bed rest with the eyes closed with no exercise or head movement. It is during this phase that antihistamines, antivertiginous and antiemetic medications may be useful. Three to five days after the onset of acute vertigo the patient will probably have spontaneous resolution of nausea and be able to partially suppress nystagmus by fixation. During this phase, mild exercise in bed (going from the supine to sitting position), practicing fixation on a slow moving finger, or maintaining fixation on a stationary finger while the head is slowly rotated in opposite directions, can be attempted. As improvement is obtained with these measures, the patient may try sitting unassisted. In five to seven days, after resolution of all nausea and only mild residual vertigo, the patient should be able to totally suppress nystagmus by fixing on an object. There may still be nystagmus with fixation removed (frenzel lenses). At this stage the patient can try resting on all four extremities, then resting on both knees, and if this is tolerated well the patient may stand erect with legs spread apart. As symptoms improve, opening and closing the eyes with the neck extended may be attempted. As balance improves, an aggressive eye tracking exercise can be performed by having the patient follow a finger through rapid transitions of gaze or fixating on an object while the head is rotated back and forth at ever faster rates. Generally within two to three weeks all vertigo ceases and even spontaneous nystagmus with frenzel lenses is reduced. At this stage the patient may try balance walking in the tandem position with the eyes closed and the head extended. Drug therapy is effective only in the first three to five days, and is intended to reduce the severe vertigo and nystagmus in the acute phase. The overall goal is for brainstem compensation mechanisms to readapt to the altered signals. Continued use of medication after five days may actually delay recovery. Exercises using eye, head, and body movement are designed to actually provoke the sensory mismatch and allow this compensation to more rapidly be accomplished.

Meniere's Disease. Meniere's disease (endolymphatic hydrops) is a common cause of recurrent vertigo and auditory symptoms, and accounts for approximately 10 percent of with patients vertigo. Early in the course of Meniere's disease there is a fluctuating hearing loss in the low frequencies, a sensation of ear fullness or pressure, and tinnitus (unilateral and may persist between episodes). There may be prolonged vertigo reaching its maximum over minutes and resolving over hours with associated postural imbalance and nausea. There is often a low tolerance for loud noises. Early in the course of the disease the hearing loss is reversible but as the disease progresses, the hearing loss becomes permanent, usually affecting the low frequencies initially. Late in the course of the disease vestibular drop attacks, due to loss of reflex postural tone, may cause sud-

den falls to the ground. During the vertigo attack, which usually lasts 30 to 60 minutes, a characteristic nystagmus is seen, with the fast phase away from the affected ear. Following the attack, during the recovery phase, the nystagmus beats toward the side of the lesion.

The main abnormality in Meniere's disease is endolymphatic hydrops, which is distension of the endolymphatic sac. As the membranous labyrinth progressively dilates, it makes contact with the foot plate or aqueduct, initially affecting the auditory system. As the disease progresses there is disruption of otolith organs and semicircular canals, resulting in the vestibular symptoms. Dilatation of the membranous labyrinth leads to the rupture of endolymph membrane. This rupture allows endolymph to leak into the perilymph, which causes immediate damage to the auditory and vestibular hair cells and nerve fibers.

Distension of the endolymphatic sac may be due to two causes; insufficient fluid reabsorption by the endolymphatic sac, or blockage of the endolymphatic duct. Several etiologies have been identified in Meniere's disease. Approximately 50 percent of the patients have a positive family history, suggesting some type of genetic predisposition. Trauma, infection, or inflammation may block the endolymphatic sac, blocking reabsorption, and leading to endolymphatic sac distension. Thirty percent of patients with Meniere's disease will progress to bilateral involvement. Up to 80 percent will have remission lasting over five years, however in some patients the progression of symptoms may be quite disabling.

The diagnosis of Meniere's disease is based on the characteristic clinical history. A number of clinical tests have been developed. In classic Meniere's disease the low frequency hearing loss will reverse itself upon administration of a dehydrating agent such as oral glycerol. In the classic diagnostic response, the hearing loss will improve by at least 15 to 20 decibels within one to two hours after oral glycerol. Medical therapy is the mainstay of treatment for Meniere's disease. Commonly employed therapy includes a low salt diet (800 to 1000 mg of sodium a day) combined with a diuretic such as hydrochlorothiazide 50 mg QD.

Perilymphatic Fistula. Perilymphatic fistula is a cause of episodic vertigo and sensorineural hearing loss. The vertigo is usually not as severe as in benign positional vertigo and there is usually a history of trauma or ear surgery. The trauma may be relatively trivial and may have occurred after diving, strenuous exercise, exertion, or air travel. Generally the symptoms of vertigo are precipitated by some type of exertion, valsalva, or position change. The symptoms generally last somewhat longer than benign positional vertigo. The pathology involved in perilymph fistula is elasticity of the bony labyrinth around the round or oval window. Because of this elasticity any increase in venous pressure or middle ear pressure can be directly transmitted into the membranous labyrinth of the auditory-vestibular apparatus. This is the basis for several of the

Neurology

fistula tests, designed to increase this pressure. Common fistula tests include compression on the tragus, applying positive or negative pressure, or a loud noise to the tympanic membrane, or having the patient swallow or valsalva. Exacerbation of symptoms with these maneuvers would suggest perilymph fistula; however, vertigo may be induced by valsalva in the Chiari brain stem malformation. Causes of post traumatic vertigo include benign positional vertigo and cervical (whiplash) vertigo, as well as perilymph fistula. Management of perilymph fistula includes bedrest, head elevation, and avoiding valsalva maneuvers by using stool softeners. If the symptoms persist and remain disabling after four months then surgery should be considered.

Positional Alcohol Nystagmus and Vertigo. Anyone who has “tied one on” can attest to the severe disorientation and vertigo that accompany alcohol excess. When alcohol exceeds 40 mg percent, the alcohol diffuses into the angular accelerometers of the semicircular canal. Because it diffuses into the cupula (hair cell area) faster than into the surrounding endolymph, there is an imbalance between the respective specific gravities. This turns the angular accelerometers into linear accelerometers and makes them susceptible to any gravitational position change. Positional vertigo and nystagmus develop (with the nystagmus fast phase component beating to the lower or down most ear). As the alcohol gradually diffuses into the endolymph it equilibrates and three to five hours after cessation of alcohol consumption, this positional vertigo resolves. As the alcohol is metabolized it diffuses out of the system, leaving the hair cell (cupula) region before leaving the endolymph, again causing an imbalance between the endolymph and the hair cells. This phase occurs five to ten hours after drinking and the fast phase of nystagmus now beats toward the upper ear, usually as the alcohol level drops below 20 mg percent. This imbalance causes the significant disequilibrium and motion sickness which is a major component of a hangover. A morning-after drink may temporarily reequilibrate the specific gravity differential between the endolymph and hair cells, causing a reduction in symptoms; however, this is only a transient effect. This imbalance may persist 10 to 12 hours after the last drink, and this is one reason why alcohol consumption should cease at least 12 hours prior to flight activities.

Toxic Vestibulopathies. Toxic substances known to cause vertigo and auditory symptoms include heavy metal exposure and medications. Aminoglycoside antibiotics such as streptomycin and gentamicin are known vestibular toxins, while neomycin and kanamycin are ototoxic. Other vestibular and ototoxic medication include aspirin intoxication (tinnitus is common in therapeutic doses), chloroquine, lasix, quinidine, and quinine (including tonic water). Toxic vestibulopathies may persist.

Less Common Causes of Peripheral Vestibular Dysfunction. Other causes of peripheral vestibular dysfunction include diseases of the bony labyrinth, such as Paget’s disease, otosclerosis, chronic mastoiditis, and congenital or acquired syphilis. Labyrinthine infarction

associated with vascular disease may cause episodic vertigo. Autoimmune disease such as Cogan's Syndrome (episodic vertigo, tinnitus, bilateral, deafness, and interstitial keratitis-photophobia, ciliary injection, decreased vision) may affect the auditory-vestibular system.

Central Vestibular Vertigo. Central causes of vertigo are less common than peripheral or systemic causes. Although lesions of the vestibular nuclei and the vestibular portion of the cerebellum may cause vertigo, nystagmus, disequilibrium, and nausea, there are usually other signs of central nervous system dysfunction. Symptoms result from involvement of brain stem structures responsible for eye movement, speech, sensation of the face, extremities, and trunk, and motor control of the facial muscles and extremities. Causes of vestibular vertigo run the spectrum of neurological disease including migraine, vascular disease, epilepsy, demyelinating disease, neoplastic disease, degenerative disease, infectious disease, and congenital malformations. The presence of other neurological signs helps distinguish central from peripheral vertigo. Central vertigo tends to be less severe with fewer autonomic symptoms (such as nausea and vomiting). Central vertigo tends to persist over longer periods of time and tends to occur in less sudden or severe attacks, except in the case of migraine or vascular disease. Evaluation of nystagmus, discussed in the section on vestibular function testing, may help differentiate between central and peripheral vertigo.

Miscellaneous Causes of Central Vertigo. The Arnold Chiari malformation may result in vertigo with increased intracranial pressure, (Valsalva maneuver) or with certain positions (head hanging or neck extension, which compresses the brain stem). Multiple sclerosis is the great imitator of neurological disease. Multiple sclerosis accounts for less than five percent of vertigo, but would be a likely diagnosis if other neurological findings, such as optic neuritis and spinal cord involvement, had occurred on different occasions. A number of degenerative brain stem conditions may result in vertigo, and often have a positive family history. Meningitis or encephalitis affecting the brain stem may result in vertigo, usually in association with other cranial nerve and brain stem signs. Extrinsic and intrinsic tumors which may result in vertigo include acoustic neuroma, meningioma, cholesteatoma, chordoma, glomus jugulare tumor, epidermoid tumor, and intracranial metastasis. Intrinsic tumors of the brain stem and cerebellum also result in vertigo. Neoplastic processes usually have a slowly progressive course and rarely cause acute sudden vertigo unless they hemorrhage and suddenly increase in size.

Central Vertigo - Summary. Due to the dysfunction of brain stem compensating structures in central vertigo syndromes, vertigo, as well as the rhythmic jerking eye movements (nystagmus), may persist over considerable periods of time. Central nystagmus looks more severe than the patient's corresponding symptoms of vertigo or nausea. Postural changes tend to stimulate peripheral vertigo more than central vertigo. Peripheral vertigo tends to be reduced with fixation

Neurology

(with the eyes open). Central vertigo tends to be worse with the eyes open, because of the conflict of visual and vestibular information. With the eyes closed, the visual information is reduced, which reduces the visual vestibular conflict and reduces the sense of vertigo. Peripheral vertigo tends to fatigue with repeated head movements because of adaptation of brainstem compensation mechanisms. In central vertigo, the vertigo may not fatigue or habituate with repeated movements, however it may vary on a day to day basis.

Vestibular Function Testing

Routine clinical laboratory tests of vestibular function include electronystagmography (ENG) and brain stem auditory evoked response (BSAER). Clinical tests may help establish an etiology in patients with vestibular symptoms. Clinical testing of the vestibular system should include a general neurological examination to establish any other areas in the nervous system that may be involved. Specific vestibular tests (See Appendix 7-G) include evaluation of the vestibular spinal reflexes, the vestibular ocular reflexes, the visual ocular reflexes, station and gait, and provocative tests (posture, position, and fistula testing). The search for spontaneous or positional induced nystagmus is an essential part of this examination.

Vestibular function tests are important in establishing the type of nystagmus, and whether it is central or peripheral in etiology. Central types of nystagmus imply a more serious prognosis and usually requires referral to a neurological center for further evaluation including neuroradiological studies. As with all neurological evaluations the associated neurological findings may be very pertinent in establishing the diagnosis. Specialized tests for evaluating vestibular dysfunction, such as the vestibular ocular reflex pendular eye tracking (VORPET) test, and the visual vestibular interaction test (VVIT), are available at the Naval Aerospace Medical Institute.

Vestibulospinal Reflexes. Vestibulospinal reflex tests include test of posture, extremity drift, station, and gait. One test of the extremity vestibulospinal reflex is past pointing which is a reactive deviation of the extremities caused by an imbalance in the vestibular system. In past pointing, which is different from cerebellar dysmetria (finger to nose test), the patient extends his arms and touches his index finger to the examiner's index finger. The patient then closes his eyes, raises his extended arm to the overhead vertical position, then attempts to return his index finger to the examiner's. Damage to the vestibular system causes lateral deviation of the arm and finger on returning to the original position. This assumes that other extra-labyrinthine function is intact (i.e., no weakness). With acute peripheral vestibular dysfunction past pointing occurs toward the side of the lesion, however with compensation, past pointing will cause deviation to the opposite side of the lesion. Another variant of past pointing is the Quix test. The patient stands, eyes closed, with arms straight ahead. Lateral drift would be considered a positive (abnormal) test.

Another vestibulospinal reflex test is the patient's stance or station, the Romberg test. There are three Romberg positions, the standard Romberg (feet next to each other), the Tandem Romberg (the patient stands with one foot in front of the other), and the Sharpened Romberg (same tandem stance but with the patient's head placed first straight ahead then in full neck extension looking at the ceiling). The patient is tested in each position with the eyes opened then closed, observing for deviation or falling, which is usually toward the damaged side. The sharpened Romberg is very difficult, and may be made more difficult by having the patient stand on one foot or placing the hands on the opposite shoulders. The time that the patient remains erect is recorded (best of three trials). A healthy naval aviator should be able to stand in the Sharpened Romberg position with the head extended and eyes closed for 30 seconds, and on one leg with hands on his shoulders for 10 seconds.

Another test of the vestibular spinal reflex is the step test. In the Fukuda Step Test the patient walks three steps forward then three steps backward, with his eyes closed for at least 20 cycles, looking for deviation or rotation toward one side. This indicates labyrinthine dysfunction in the absence of cerebellar or proprioceptive dysfunction. The Unterberg step test is conducted in a similar fashion with the patient essentially marching in place over the same spot, again looking for deviation or rotation. Tandem gait should be tested looking for deviation.

Vestibular Ocular Reflex Tests. Vestibular ocular reflex testing can be done in a variety of ways. A very sensitive test is the dynamic illegible E test, which involves having the patient read a visual acuity chart while rotating the head in the horizontal, vertical or lateral tilt planes, at a frequency of approximately two cycles per second. This may be done starting in the primary position, rotating the head side to side (testing horizontal canals), then up and down (testing vertical canals). The head is placed left or right then rotated up and down, as the patient continues to read the chart. The head is then tilted backwards or forwards (neck extended or flexed) and the head is rotated side-to-side. This version of the dynamic illegible E test places the eyes at the extremes of gaze. Ordinarily there should be no decrement of visual acuity while performing this test unless there is dysfunction of the vestibular ocular reflex (VOR). The VOR may be tested by Barany chair rotation with the eyes closed. The chair is rotated 10 rotations in 20 seconds and then post rotatory nystagmus is observed.

Bedside caloric testing is performed by irrigating the external auditory canal with water at 44° C and 30° C. The fast phase of nystagmus will develop in the direction opposite to the side irrigated with cold water and vice versus with warm water. In peripheral labyrinthine dysfunction the caloric responses are diminished on one side using hot and cold water, while in central lesions the eye movement shows a directional preponderance (the nystagmus is more prominent in one direction than the other direction).

Neurology

Visual Ocular Reflex Tests. The visual ocular reflex test involves visually induced (optokinetic) nystagmus. This is tested with the optokinetic tape moved in one direction, then the opposite direction, in both horizontal (left and right), and vertical (up and down) planes. A similar optokinetic visual ocular reflex can be tested in the Barany chair by having the patient stare off in the distance as the chair rotates. This induces a full field optokinetic response, which should be tested in each direction.

Position Tests. Position tests are used to stimulate eye movements. The head hanging, lateral decubitus, and Hallpike positions are common provocative position tests. Head hanging involves placing the patient in a supine position with the head and neck extended backward over the exam table. The eyes should be tested both with fixation (staring at an object) and without fixation (using high plus cataract glasses or Frenzel lenses). Next the patient should be tested in the lateral decubitus position with the ear down to stimulate positional nystagmus and vertigo. The Hallpike (Dix-Hallpike) maneuver, used to stimulate nystagmus and vertigo, involves rapidly taking the patient from the sitting position with the head and neck straight ahead to the supine position with the head and neck extended 45 degrees and rotated 45 degrees, and with the patient looking toward the ground. The maneuver is tested in both directions and the eyes observed for at least 60 seconds for the development of classic positional induced nystagmus. Nystagmus that is only elicited in one direction is characteristic of benign paroxysmal positional vertigo (BPPV).

Nystagmus Evaluation. The evaluation of nystagmus should include a description of the type of nystagmus. Nystagmus may be pendular, sawtooth, or exponential (increasing or decreasing). Classic vestibular nystagmus has a sawtooth appearance whereas pendular or exponential types indicate cerebellar or congenital nystagmus. The direction of the fast phase of nystagmus should be noted as well as whether the nystagmus is present in the primary position (looking straight ahead) or is gaze evoked, (brought on by looking in a particular direction). Characteristically nystagmus increases in amplitude when looking in the direction of the fast phase of the nystagmus (Alexander's Law). Nystagmus may be horizontal (left or right), vertical (up or down), or torsional or rotatory (clockwise or counterclockwise). In general, peripheral nystagmus tends to be mixed (looking one direction the nystagmus is horizontal while looking in the other direction it tends to be rotatory or torsional). Pure vertical nystagmus usually implies a central origin; however, central nystagmus is often mixed as well. Nystagmus may be either conjugate (nystagmus beats the same way in both eyes) or disconjugate. The latency (delay in onset) of nystagmus following a position change should be noted. Central nystagmus usually starts immediately upon the patient assuming a certain position. Peripheral nystagmus usually exhibits a delay in onset, but this is not absolute. Nystagmus that fatigues on continued evaluation (reduction in amplitude or frequency), or on repeated testing (habituation) is characteristic of peripheral nystagmus. Central compensation over time causes a reduction in frequency or amplitude of the

nystagmus. The effect of fixation on nystagmus should also be evaluated (have the patient focus on an object or a removing fixation by using frenzel lenses). The nystagmus should be evaluated in the provocative positions (head hanging, lateral decubitus, and the Hallpike position).

Fistula testing provocative maneuvers (valsalva, tragus compression) may reproduce symptoms or elicit nystagmus. Substantial vertigo and nausea of acute onset are more likely in peripheral lesions, whereas in central nystagmus the nystagmus appears to be quite prominent, however the symptoms are minimal. In general, peripheral nystagmus is inhibited by fixation. Central nystagmus shows an increased amplitude with fixation although the velocity of the slow phase may be reduced with fixation. Positional nystagmus that lasts over 30 seconds in the provocative position usually indicates central nystagmus, however 50 percent of persistent positional nystagmus cases have no identifiable etiology (idiopathic).

Disposition of Aviation Personnel with Vertigo

Obviously vertigo represents a significant threat to aviation safety because of the possibility of sudden onset, incapacitation, and unpredictability. No medications used to treat vertigo would be waived and any patient with symptoms of disequilibrium or vertigo should be grounded and a thorough evaluation should be performed. Following an evaluation and establishment of the probable cause of the vertigo, aeromedical disposition is considered. Any aviator with central neurological cause for vertigo would be found not physically qualified (NPQ) and no waiver would be recommended as inevitably compensation mechanisms would break down and generally these imply a more serious prognosis. In general, nondesignated personnel with a history of vestibular disease (central or peripheral) are NPQ with no waiver granted.

In designated aviation personnel, waivers would be granted on an individual basis. Consideration should be made for the aircraft type and mission. Meniere's disease (endolymphatic hydrops) would not be waived because it tends to be recurrent and progressive and may occur acutely. Vestibular neuronitis and benign positional vertigo tend to have a more benign course and the flier should be grounded for three to six months following relief of symptoms. Following grounding and assuming the patient has been asymptomatic, Class II personnel may be returned to flight status and aviators might be waived to Class I Service Group III status. Following a 6 month period on a Service Group III if no further symptoms had developed consideration for Service Group I or II might be entertained on an individual basis. Aviation personnel with a history of vertigo should be cautioned about excesses that may precipitate vertigo such as contact sports, alcohol consumption, and any medication, including over the counter medication.

Neurology

As always, aeromedical safety is the prime concern, and if there is a likelihood of incapacitation on an acute basis this would be a major consideration in returning someone to flight status.

Obviously no medication for the treatment of vertigo or disequilibrium would be waived. Physiologic vertigo syndromes, such as motion sickness are handled on an individual basis. Assuming a successful desensitization program, personnel may be returned to flight status in an unrestricted capacity.

Occasionally an experienced aviator may develop significant leans. This is seen in aviators after return from a non flying billet or following periods of minimal actual instrument time. These aviators may have lost or degraded their scan pattern or become overcome by the seat of the pants sensation. These flyers may benefit from extensive instrument retraining to develop proficient scan patterns. Initially this should be performed in simulators, then as progress develops they may return in dual controlled aircraft. Even complex motion simulators cannot reproduce the sustained changes in gravity vectors that occur in a banked turn or deceleration to the landing configuration that actual flight produces. As proficiency returns, the patient may return to Service Group I status.

G-Induced Loss of Consciousness (G-LOC)

G-induced loss of consciousness (G-LOC) is an altered perception wherein one's awareness of reality is absent as a result of a sudden critical reduction of cerebral blood flow caused by increased G-forces. G-induced loss of consciousness, was first recognized as an aviation hazard in World War I. The British neurologist, Henry Head, described "fainting in the air" in pilots of small fighter biplanes, particularly very maneuverable ones. He even noted that prior to losing consciousness a haze or mist covered the eyes and then finally all vision became dark. G-LOC was also identified as a problem in the air races of the 1920's. It was again recognized as a problem in World War II, particularly in dive bomber crews after pulling up from a steep dive or in fighter pilots during air combat maneuvering. With the advent of today's high technology fighter, G-LOC has again emerged as a aeromedical safety issue. Based on surveys in tactical aircrew in the U.S. Navy and Air Force, it is estimated that G-LOC occurs in 12 to 30 percent of aircrew in tactical aircraft. Several mishaps have been attributed to G-LOC. The first human studies in the United States were done in the 1938-1939 period. Several sequelae were noted, including the visual symptoms of grayout and blackout, and G-LOC, which was described as a coma which occurred between 6 - 9 G (+Gz). It was also noted that during recovery, the subject experienced a brief period of apparent bewilderment. It is now recognized that G-LOC includes both an ab-

solite period of unconsciousness and a relative period of unconsciousness. Both of these combined give a total period of incapacitation which may last up to 40 seconds.

G-LOC results from a reduction in cerebral perfusion pressure due to hydrostatic drop in blood pressure and reduced cardiac output occurring as a delayed effect of venous pooling in the lower extremities. Blood pressure at the level of the head drops 22 mm Hg for each 1 +Gz. Two physiological protective mechanisms occur during G-LOC. The first is the metabolic reserve of central nervous system neurons. After reduction of cerebral blood flow (and hence reduction in glucose and oxygen), neuron metabolism ceases. The second compensatory mechanism is the cardiovascular baroreceptor reflex which detects a reduction in blood flow at the level of the carotid body. This reflex result in reflex tachycardia and an increase in systemic vascular resistance.

Both the duration of G-stress and the G-onset rate have an effect on the development of G-LOC. The incapacitation time for G-LOC is dependent upon the G-onset rate. Incapacitation times are longer for a gradual onset rate (0.1 G per second) than with rapid onset rates (greater than 1 G per second). Although the period of incapacitation may be greater with gradual onset rates, rapid onset rates are associated with the onset of LOC without the premonitory visual symptoms of grayout or blackout. As aircrews commonly use grayout as a sign that they are approaching their G-tolerance limit, the lack of visual symptoms may result in G-LOC without any warning. Amnesia for G-LOC is common and occurs in over 50 percent of the individuals experiencing GLOC on centrifuge training runs.

G-LOC results in two types of responses. Type 1 G-LOC is of short duration, approximately 30 seconds of total incapacitation, and convulsive movements are absent. Type 2 G-LOC has a more prolonged period of unconsciousness and incapacitation and there are associated convulsive (flail) movements similar to anoxic myoclonus. The period of incapacitation is longer, usually over 40 seconds, and is often followed by a variety of symptoms, such as denial, a dream like state, confusion, paresthesias, gustatory sensations, as well as amnesia. In addition to G-LOC, G-induced pain, particularly in the cervical region, 'has been reported by aircrews.

G-LOC is reported by 12 to 30 percent of tactical aircrew. G-LOC occurs with the same incidence in pilots and aircrew (weapons systems operators and naval flight officers). Factors implicated in G-LOC include rapid G onset rate, sustained G-pull, too many Gs being pulled, anti-G suit failure, and ineffective anit-G straining maneuver. Age, height, and weight do not appear to be related to the incidence of G-LOC. In initial studies, the F/A-18 had the highest incidence of G-LOC of aircraft in the Navy inventory, but in a followup survey G-induced G-LOC appeared more commonly in the AV-8, T-2, and TA-4. This may reflect training programs designed to increase fleet awareness of G-LOC.

Neurology

A number of secondary protective mechanisms are used to combat G-LOC. Perhaps the most important of all these is a proper anti-G straining maneuver (AGSM). This maneuver involves vigorous tensing of the extremity muscles to prevent venous pooling and a cyclic increase in intrathoracic pressure, by tensing abdominal and chest muscles. The increase in pressure of the thoracic cavity is accomplished by a three second cycle (two 1/2 seconds expiration and 1/2 second inspiration). Expiration against a closed glottis, causing a groaning sound, is the classic L1 maneuver. The M1 maneuver is better tolerated because it doesn't interfere with communication. During the M1 anti-G straining maneuver, the expiration phase is performed against a partially closed glottis. An effective anti-G straining maneuver has improved G-tolerance up to four additional Gs.

The anti-G suit and anti-G suit valve, used to enhance performance in the high G environment, had its inception in the mid 1940s and underwent further technical development in the 1950s and 60s. The standard anti-G valve inflates at 1.5 PSI per G starting when 2 Gs are reached, inflating to a maximum of 10 PSI. This inflation rate may not be fast enough to provide adequate inflation. Over an extended period of high G maneuvering this may actually act as a venous occlusion cuff. Anti-G suit and valves improve G tolerance from G level of 4.5 +Gz for an unprotected individual (no anti-G suit or straining maneuver) up to 5.5 +Gz, (1 additional G). Newly developed valves increase the inflation rate in an attempt to enhance the effectiveness of the anti G suit. Development of the sequential inflating suit also holds promise. Ideally, a G-valve should inflate to 5 PSI as soon as possible, preferably in 1 second, to prevent early venous pooling. The high flow only (HFO valve) inflates 33 percent more rapidly than the standard valve and shows improvement in cardiac output during high-G maneuvers. Advanced valves such as the servo controlled anti-G valve (SCAG) and the bang-bang servo valve (BBSV), start inflating at approximately 1.5 G, and inflate at a rate of 2.5 to 5 PSI per second. A recently developed servo valve uses microprocessor technology, which integrates with the flight control systems in fly-by-wire aircraft, allows the anti-G valve to respond to flight control inputs prior to the rapid onset of Gs.

The seat angle is another factor in the G enhancement program. The standard tactical seat back angle is approximately 13 degrees. In the F-16 a 30 degree seat back angle is used and this improves G tolerance by an additional 1 G. New engineering technologies are looking at the movable seat angle (supinating seat) which will allow a seat angle of up to 75 degrees, which improves resting G-tolerance to up to 8 Gs. The supinating seat will have significant cockpit engineering challenges, due to difficulty with escape systems, headrest angle, restricted rear visibility, and an increase in chest pain, discomfort, and dyspnea with the increased seat back angle.

G-tolerance conditioning includes avoidance of G degrading factors, aerobic physical conditioning programs, and centrifuge training. The Air Force has conducted a vigorous centrifuge

training program for their tactical aircrews. The aircrews have shown an improvement in G-tolerance after practicing the anti-G straining maneuver in a realistic environment and pilot awareness of the premonitory G-LOC symptoms has been improved.

Positive pressure breathing may also improve G-tolerance. Unassisted positive pressure breathing is probably of limited value. The addition of chest counter pressure and face mask positive pressure breathing, called assisted positive pressure breathing (APPB), increases blood pressure and facilitates inspiration, both considered beneficial in the high G environment. Assisted positive pressure breathing is less effective in protecting against G-LOC if the patient is relaxed prior to high onset G rates, but would be effective in combination with the rapidly acting G-value or a supinating seat. Positive pressure breathing system increase at a rate of 12 mm HG per G after reaching 4 G, up to the maximum of 60 mm of HG. A distinct advantage of assisted positive pressure breathing is the reduction in fatigue from breathing and performing the anti-G straining maneuver. This may improve G-tolerance, particularly during the sustained high G environment of air combat.

The final category of protective mechanisms against G-LOC are aircraft recovery systems, currently in the research phase, which assess pilot and aircraft performance. Two mechanisms are involved in recovery systems. One method involves stimulation of the pilot by either auditory or visual signals in an attempt to arouse the person prior to G-LOC. Another technique is a positive aircraft control recovery system which would control the aircraft following G-LOC if the aircraft entered a nose down attitude at low altitude. A number of physiological monitoring systems, have been developed. During G-LOC the electroencephalogram (EEG) shows high amplitude slow waves during the period of incapacitation. Another method involves assessing cerebral metabolism using near infrared spectrophotography detectors placed over the head. The near infrared cerebral metabolism monitor can assess hemoglobin, oxygenation, and blood volume in the brain. Another method of detecting G-LOC involves the EKG pulse wave delay. Normally there is a delay between the R wave on the EKG and the arterial pulse wave recorded over the skull or scalp. This pulse wave can be detected using ultrasound doppler over the superficial temporal artery, infrared optical reflective plethysmography over the forehead, or the peak enhanced electroencephalogram, called the rheoencephalogram. Normally this pulse wave delay increases with increasing Gs, and this delay increase may be used as a tool for detecting G-LOC before it actually occurs.

The acceleration and performance of modern tactical aircraft has improved beyond the pilot's physical ability to tolerate them. With advanced aircraft technology, aircrew engaged in air combat maneuvering will be increasingly exposed to potentially hazardous situations. The incidence of G-induced LOC will increase if protective mechanisms and technology are not developed and

implemented. With improved centrifuge training, physical conditioning, proper performance of the anti G-suit and valve, seat angle, positive pressure breathing and recovery systems, the physiological effects of the high G environment in air combat can be lessened and our aircrews given the tactical advantage to win in combat.

Management of Coma and Unresponsiveness

Consciousness is a state of awareness and appropriate interaction with the environment. There are two aspects of consciousness which come into play in evaluation of a comatose patient. First is the level of content i.e. mental and cognitive function, and second, level of arousal (i.e. the degree of wakefulness). An alteration or reduction in consciousness is due to either diffuse or bilateral impairment of the cerebral hemispheres (cortex) or dysfunction of the brain stem reticular activating system. Clouding of consciousness implies either an inappropriate content or inappropriate level of arousal. Early in the course of coma, a patient may exhibit alternating excitability and drowsiness, incorrect sensory perceptions, decreased attention span, or misinterpretation of external stimuli. Dementia or senility implies an irreversible loss of cognitive function and memory and is usually seen over a more protracted course although it may be acutely precipitated by other problems such as electrolyte derangement. Delirium is a more agitated state of disorientation where the patient's level of arousal may be increased, however his content is markedly reduced. This is a common feature of toxic and metabolic encephalopathy, drug overdose, major organ failure, severe head injury, systemic infection, or subarachnoid hemorrhage.

The degree of drowsiness is often misrepresented on the patient's record. The terms obtundation, stupor, and coma are often used interchangeably. It is best to note the response the patient makes with their environment (i.e., responds to soft verbal stimuli, loud verbal stimuli, physical stimuli such as shaking, or deep painful stimuli to the extremities). Coma or absence of arousal to any external stimuli is mimicked by several other clinical conditions which may be confused with coma. These conditions include: (1) locked in syndrome, (2) psychogenic coma, (3) persistent vegetative state, (4) akinetic mutism, (5) hypersomnolence (exaggerated sleep response,) and (6) brain death.

Locked in syndrome is seen in brain stem infarction or metabolic conditions which cause paralysis of all four extremities without loss of consciousness, or acute motor paralysis due to peripheral nerve or neuromuscular junction blockade. There may be preservation of eye movements and blink reflex. Communication may be established by eye blinks. Psychogenic coma should be considered if the patient has intact brain stem reflexes, including caloric, nystagmus, pupillary reactions, and optokinetic nystagmus. In psychogenic coma there is an active resistance to eyelid opening and the eyes will tend to avoid looking at the examiner. Persistent vegetative state resembles coma. This condition occurs from severe injury to higher

cortical structures resulting in a total lack of response to the external environment, however the patient may still have sleep and wake cycles and spontaneous eye opening. Akinetic mutism results from damage to specific areas of the frontal or limbic cortex, resulting in a loss of interest in the environment, even though the patient may appear otherwise neurologically normal. Excessive sleepiness (hypersomnolence) conditions may mimic comatose states. Brain death may also mimic coma.

Nonpsychiatric (organic) coma may be due either to structural, metabolic, or toxic conditions. Structural lesions may involve the supratentorial or infratentorial regions. A history of drug abuse, headache, fever, or previous medical condition might be significant. The patient may not be able to provide a history, so much of the evaluation will depend on the examination and diagnostic tests.

Examination

The general physical examination should include the vital signs. Evaluation of the skin may reveal needle tracks, cyanosis, dehydration, rash (Meningococcal infection), or uremia. Bullous skin lesions may occur from drug effect (barbituates, carbon monoxide, phenothiazine, imipramine and meprobamate). Breath may reveal alcohol, acetone, hepatic failure, or uremia. Cardiac examination may be helpful in finding a murmur, suggesting endocarditis; or arrhythmias, which may result from subarachnoid hemorrhage or a brain stem lesion. Hypothermia may be due to exposure, overwhelming sepsis, drug effect, hypoglycemia, hypothyroidism, or Wernicke's encephalopathy. Altered ventilatory patterns may be indicative of metabolic acidosis or respiratory alkalosis. The neurological examination should include a general assessment of consciousness, including response to voice, or painful stimuli. Cranial nerve evaluation is important particularly the pupillary light reflex. It is important to use a bright light when evaluating pupillary responses. Local eye trauma, cataracts, or eye surgery may alter the pupillary response. Preservation of the pupillary light reflexes suggest metabolic coma. Atropine (given following cardiac arrest) amphetamine intoxication, and postanoxia may cause fixed and dilated pupils.

A fixed midposition pupil may be seen with hypothermia or glutethimide. Small, fixed pupils may be seen with opiates, organophosphates, pilocarpine, phenothiazine, and following respiratory arrest from barbiturates. Brain herniation may result in fixed pupils even though the herniation may be a primary metabolic process such as cerebral edema. The position of the eyes in their primary resting position should be recorded and whether they are conjugate or disconjugate, abnormal deviation (horizontal or vertical), and spontaneous eye movements (roving eye movements, bobbing, or nystagmus) should be evaluated. Assessment of brain stem

Neurology

reflexes should include the corneal reflex, gag reflex, stemutatory reflex, oculocephalics, and vestibular reflexes. Motor function testing should assess spontaneous movements, such as myoclonic jerks posturing, asterixis, or seizure activity, or if response to stimuli is appropriate, purposeful, or nonpurposeful.

Some general rules apply in the comatose patient. Usually, focal neurological signs indicate a structural lesion, however focal signs may be seen in Todd's paralysis following a generalized seizure disorder or if there is a preexisting focal deficit such as an old stroke. Nonfocal neurological signs usually indicate toxic or metabolic coma, however nonfocal signs also occur in subarachnoid hemorrhage, bilateral subdural hematoma, or vasculitis. A fluctuating neurological examination usually indicates a toxic or metabolic coma, but may also be seen in fluctuating intracranial pressure elevation or status epilepticus (during the refractory or twilight phase). Toxic or metabolic coma usually has an incomplete and symmetric affect on the nervous system, affecting many levels of the neuraxis simultaneously while retaining integrity at other levels. In metabolic coma there is no regional (focal) anatomic defect such as occurs in structural coma. Toxic and metabolic coma generally does not cause impairment of horizontal and vertical vestibular ocular reflexes (Doll's eyes). Respiratory patterns may localize the level of the neurological lesion. Damage to the cerebral hemisphere may result in "Cheyne-Stokes" respiration, a hyperventilation pattern with a crescendo- decrescendo amplitude. Damage to the midbrain and higher brain stem structure may result in central neurogenic hyperventilation, which is a hyperventilatory pattern in excess of 20 respirations per minute without the crescendo amplitude seen in Cheyne-Stokes respiration. Damage to the midbrain or pons may cause apneustic or cluster breathing, resulting in a prolonged pause following inspiration. Finally, with damage to the lower brain stem region the medulla ataxic breathing, similar to a hiccup pattern, may be seen. Hiccups often imply an impending neurological crisis involving the lower brain stem (medullary chemotactic trigger zone). Respiratory patterns suggest involvement at certain levels but are not always diagnostic.

Laboratory Assessment

A screening laboratory evaluation may aid in establishing the cause of coma. Neurological effects often outlast metabolic electrolyte derangement. Evaluation should include complete blood count, electrolytes, arterial blood gases, toxin and drug screens. The electroencephalogram, CT scan, and lumbar puncture may also aid in diagnosis. Treatment for coma should include: (1) the initial establishment of the ABCs (2) Thiamine 100mg IV push, (3) Dextrose 50 ML of D50W (4) Narcan 2 amp IV push. Once the patient is stabilized from a circulatory and respiratory standpoint, signs of impending herniation syndromes should be sought. If a herniation syndrome is present the patient should be treated for intracranial pressure

evaluation. Treatment of coma is dependent upon establishing the etiology. The diagnostic tests described above are useful in establishing the appropriate cause. As with all evolving neurological crises, it is extremely important to continually reassess the patient with serial examinations.

Disposition of Naval Aviation Personnel Following Head Trauma

Current policy with regard to disposition of aviation personnel following head trauma is determined by the period of posttraumatic amnesia (PTA) and the associated risk of posttraumatic epilepsy (PTE). The current guidelines state that for a period of amnesia of less than one hour, the patient should be grounded for a period of three weeks. For moderate brain injury associated with PTA of one to 24 hours, grounding for 12 months was recommended. For severe brain injury (i.e., with PTA greater than 24 hours) grounding for 30 months was recommended. Injuries causing PTA of over one hour are considered disqualifying (CD) with waivers considered. For mild and moderate injury in Class II personnel, waivers are considered after shorter grounding periods.

Head Injuries in Aviation Personnel Requiring Aeromedical Disposition

1. Loss of consciousness or inability to recall events for more than five minutes after the accident (see Tables 7-1 and 7-2).
2. Neurological deficit, or loss or alteration of motor, sensory, or special sensory (vision, hearing) function.
3. Substantial laceration or contusion of scalp (may indicate more substantial CNS injury).
4. Otorrhea, rhinorrhea, or any skull fracture.
5. Any penetrating head injury.
6. Posttraumatic seizure.
7. Cranial computed tomography evidence of hematoma including epidural, subdural, or intracerebral hematoma.

Aeromedical disposition of head injured aviation personnel should be based on:

1. Absence of physically disqualifying conditions.
2. Absence of posttraumatic syndrome.
3. Risk of posttraumatic epilepsy (as determined by period of posttraumatic amnesia).
4. Cognitive function.

Following mild head injury, patients often have vague neurological sequelae. This has been termed the posttraumatic syndrome or postconcussive syndrome. Common symptoms of the

Neurology

posttraumatic syndrome include headache, emotional lability, personality and mood changes, poor concentration, sleep disturbance, fatigue, imbalance, and disequilibrium. These symptoms are often subtle and only noticed by close friends or relatives. Because the onset of these symptoms is delayed following apparent recovery from mild head injury, an appropriate grounding interval is indicated even after relatively insignificant neurological injury.

Table 7-1

Gradation of Brain Injury

Brain Injury	Loss of Consciousness or Posttraumatic Amnesia	Glasgow Coma Scale Score
Minimal	less than 5 minutes	15
Mild	less than 1 hour	13 to 15
Moderate	1 to 24 hours	9 to 12
Severe	1 to 7 days	3 to 8
Very Severe	more than 7 days	3 to 8

Personnel with asymptomatic head injuries will be placed in two groups based on the presence or absence of disqualifying conditions (see Head Injury Groups 1 and 2). These disqualifying conditions represent a high risk for the development of posttraumatic epilepsy, and for which no waiver could be recommended. Head injuries may occur away from the local command and acute management is often made by civilian providers. Every effort should be made to obtain pertinent medical records and X-rays (i.e., CT scans) as the patient will usually not be able to provide complete details. After review of the records, those without a physically disqualifying condition would then be assessed for cognitive dysfunction after an appropriate grounding period. These recommended grounding periods are guidelines and are conservative. Waivers occasionally are considered after shorter grounding periods. Individual cases may be considered depending on such factors that may effect post traumatic amnesia (PTA), such as post injury medication anesthesia, or inadequate records (i.e., failure to adequately assess the return of normal memory). Formal amnesia screens, such as the Galveston Orientation and Amnesia Test (GOAT) (See APPENDIX B), administered as soon as possible, may obviate the need for prolonged grounding because of delayed evaluation (artificially prolonged amnesia period). It is incumbent upon the squadron Flight Surgeon to assess the flyer as soon as possible following a head injury to assist in potential aeromedical disposition problems.

Table 7-2

Glasgow Coma Scale

Response	Score
Eye Opening	(E)
Spontaneous	4
To speech	3
To pain	2
Nil (no response)	1
Best Motor Response (Test each extremity)	(M)
Obeys	6
Localizes	5
Withdraws	4
Abnormal flexion	3
Extensor response	2
Nil (no response)	1
Verbal Responses (Indicate if patient can't talk, e.g., intubated)	(V)
Oriented	5
Confused conversation	4
Inappropriate words	3
Incomprehensible sounds	2
Nil (no response)	1
Coma Score (E + M + V) =	3 to 15

A factor often neglected in determining the return to flight status following head injury is the cognitive dysfunction sustained from head injury. Assessment of cognitive dysfunction should be included in the evaluation of aviation personnel with head injuries of moderate or severe nature (as judged from the length of PTA), especially those who are being considered for an up status after a shorter interval than traditionally recommended. A cognitive assessment computer software program has been developed to evaluate aviation specific cognitive abilities (Unified Triservice Cognitive Performance Assessment Battery), and will soon be available to the fleet. Routine

Neurology

neuropsychometric testing, such as the Wechsler Adult Intelligence Scale, MMPI, Halstead Test Battery, and Trail Making Test, are available at major medical treatment facilities. A NATOP's Flight Simulator check ride could also function as a screen for cognitive dysfunction. Should cognitive assessment testing be within age matched standards, then a return to flight status would be granted if the patient is otherwise asymptomatic. For those demonstrating deficits on cognitive assessment, retesting could be considered after a period not to exceed their original grounding period. Following the determination of up-status, aviation personnel should undergo a low pressure chamber (altitude chamber) run to evaluate adverse hypoxic effects on the CNS, and to ensure the sinuses clear adequately after head injury.

Head Injury Groups

Group 1 No Neurologically Disqualifying Defects. Personnel with asymptomatic head injuries will be placed in Group 1 if the following conditions are absent: neurological deficits, hematoma, depressed skull fracture or seizures.

1. *PTA More Than Five Minutes and Less Than One Hour.* Ground for three weeks. If no sequelae, normal exam, then patient is PQ.

2. *PTA From 1 to 24 Hours.* Ground for 12 months, classify as NPQ, reevaluate and consider for waiver if there are no sequelae and results of cognitive function tests are normal.

3. *PTA Longer Than 24 Hours.* Ground for 30 months, permanent NPQ; reevaluate every year, consider waiver after grounding if no sequelae are present and normal results are obtained on cognitive function tests.

Group 2: Neurologically Disqualifying Defects. If any of the following conditions are present, asymptomatic head injury patients will be placed in Group 2 and the disposition will be as follows:

1. Depressed Skull Fracture. NPQ and No Waiver.
2. Intracerebral Hematoma. NPQ and No Waiver.
3. Neurological Deficit. NPQ and No Waiver.
4. Dura Penetrated. NPQ and No Waiver.
5. Seizures. NPQ and No Waiver.

Management of Acute Spinal Cord Injuries

Introduction

Injury to the spinal column and spinal cord represent one of the most significant injuries in terms of medical complications and economic impact. Like head trauma, spinal cord injury can be divided into penetrating and nonpenetrating injuries. The majority of the injuries are nonpenetrating, and are usually due to deceleration forces from motor vehicle accidents, airplane crashes, falls, diving accidents, contact sports, or crush injuries. The injury may affect the spinal column (bone and ligaments), spinal cord (neural elements), or both.

Classification of Spinal injuries

Spinal injuries are classified according to: 1) the mechanism of impact leading to the injury, 2) or the pathophysiological damage to the spinal cord and column. Spinal column injuries are divided into: 1) fractures, 2) dislocations, or fracture-dislocations (the most common type). Injury may affect the ligaments (dislocation), the osseous elements (fracture), or both. Following initial stabilization of the injury, it is important to identify the level of injury, bearing in mind that approximately one third of spinal injury patients may have other systemic injuries or another level of the spine affected.

Spinal cord injuries may be classified according to the area of cord damaged or the extent of clinical symptoms: (complete versus partial; anterior cord, posterior cord, or central cord). Vertebral injury may be classified according to the direction of force vectors applied to the vertebral column. These injury patterns include flexion, extension, axial compression, lateral flexion, rotation, or a combination of patterns. Flexion and extension may be further subdivided into disruptive or compressive injury (flexion and extension). Certain predisposing factors can aggravate or precipitate acute spinal injury, such as preexisting spondylitic disease, osteoporosis, ligament hypertrophy, or spinal stenosis.

Evaluation of Spinal Injuries

Spinal injury, particularly cervical spinal injury, should be suspected in anybody who has sustained an injury above the clavicle, or who has sustained head injury and is unconscious. Other clues to the presence of a spinal cord injury include neck or back pain, tenderness on palpation, a step-off deformity, muscle spasm or swelling, an electrical sensation with neck movement, flaccid extremities, absent reflexes, incontinence, diaphragmatic breathing, or asymmetric weakness (distal greater than proximal), and priapism.

Management of Spinal injuries

As with management of acute head trauma, the most important aspect is to ensure the ABC's, (airway, breathing, and circulation). Throughout the initial management of the trauma patient it is extremely important to prevent further damage to the spinal cord. This is accomplished by avoiding flexion or extension of the neck, and maintaining neutral head position. Prior to extraction, the patient should be placed on a short spine board and immobilized with sandbags, tape, or straps. Plastic IV bags may be used in lieu of sandbags. The patient should be lifted onto a long spine board and then secured with straps. Obviously in a situation where the patient is in a dangerous position, such as a burning aircraft, these considerations would have to be hastened or bypassed to save the individual's life. In general, the plastic Philadelphia collar or the Hare extrication collar should be used in combination with sandbags, tape, and spine boards. These collars primarily limit extension, but do little to limit flexion.

Examination should include palpation of the cervical, thoracic, and lumbar spine, an adequate motor, sensory, and reflex examination of the upper and lower extremities, and a rectal exam. Continued reassessment of the ABCs and neurological examination are indicated. Significant injuries of the upper thoracic spinal column are often associated with respiratory distress from flail chest, hemopneumothorax, or circulatory compromise from aortic arch dissection, myocardial contusion, or cardiac tamponade. Injuries to the lower thoracic spinal column are often associated with intra-abdominal injury and renal damage. Delayed neurological deterioration in a spinal injury patient could signify the development of a spinal epidural hematoma, spinal abscess, or vascular or neural compromise of the spinal cord. Injuries to the thoracic and lumbar spinal column are common complications of aircraft accidents, and occur in 30 to 60 percent of ejections or crash landings. In acceleration/deceleration in the G_x plane, the greater mobility of the cervical spinal column accounts for a higher incidence of injuries to the cervical spinal cord. Injuries in the thoracolumbar area may result in significant neurological sequela, because there is less space available for the cord in this region. Spinal cord blood supply in the thoracolumbar region is tenuous compared to the high thoracic and cervical areas. Injury forces required to injure the thoracic spinal column involve a greater amount of destruction and displacement, which may result in intra-thoracic and intra-abdominal injuries.

Prior to transport of the spinal injury patient, it is extremely important to adequately pad areas that have become anesthetic from the spinal injury. Casting of an anesthetic extremity should be avoided. An alternative would be to apply bivalved casts, splints, or external fixation devices. Spinal cord injury patients often have urinary drainage complications and may require intermittent catheterization or an external condom catheter. Treatment with ascorbic acid and Mandelamine helps to reduce urinary tract infections. Prophylactic treatment with antacids is

also important as these patients are prone to stress ulcers. Long term complications from spinal cord injury include pneumonia, pulmonary embolism, gastrointestinal hemorrhage from ulcers, renal stones, urinary tract infections, and decubitus ulcers. Attention to the nursing management problems in spinal cord injury patients is essential to preclude or alleviate these complications. The use of glucocorticoids and antibiotics remains a controversial area and should be given only at the direction of specialty consultants. Referral to a neurosurgical center should be accomplished as soon as feasible for any patient with a neurological deficit or unstable spinal injury.

Spinal Radiography

Following spinal stabilization on a long spine board and a neurological evaluation including sensory, motor and reflex examination, the patient should undergo radiographic evaluation (see cervical spine radiology sheet). The acutely injured patient should undergo cross table lateral C-spine X- ray which should include the C7-T1 level. When stable, AP radiographs of the cervical, thoracic, and lumbar spine should be obtained, as well as an open mouth odontoid. Radiographic findings that may simulate fractures or ligament injuries include the pseudosubluxation of C2-C3 (seen in one to seven year olds), incomplete ossification of the posterior elements, spina bifida, the mach band variant, unfused secondary ossification centers (apophysis), butterfly vertebra, or soft tissue ossification.

The following provides a general approach to evaluation of cervical spine films.

Abnormal Findings on Cervical Spine Radiology.

1. Soft Tissue

- a. Widened prevertebral fat stripe (C-2) > 7 MM
- b. Widened retropharyngeal space (C-3) > 5 MM
- c. Widened retrotracheal space (C-6): child > 14 MM, adult > 22 MM
- d. Tracheal deviation/laryngeal dislocation on AP film.

2. Vertebral Alignment

- a. Loss of lordosis
- b. Kyphotic hyperangulation > 11 degrees
- c. Torticollis
- d. Widened interspinous space
- e. Vertebral body rotation
- f. Space available for cord (SAC) < 14 MM.

3. Joint Abnormalities

- a. Axis-Dens interspace (ADI): child (< 8yr) > 5MM, adult > 3 MM
- b. Disc space disruption
- c. Apophyseal joint widening.

Use of the Gardner-Well Tongs

Ideal management of the suspected spine injury patient involves the use of skeletal traction, such as the Gardner-Wells or Crutchfield tongs. These require either mechanical weights or spring tension devices, usually seven to 10 pounds. In aeromedical evacuation, the William's traction apparatus, which is attached to the standard military litter, is the preferred method of applying weight to the tongs. The Williams traction apparatus provides tension from a spring device and avoids the swinging weights which might aggravate a medivaced spinal cord injury patient.

The Gardner-Wells tongs should be placed over the patient's scalp, and if time permits, an area of the scalp over the tong insertion point should be shaved and prepped with an antiseptic solution and infiltrated with local anesthetic. Placement of the Gardner-Wells tongs is approximately two finger widths above the external ear in the plane of the external auditory canal. The squamosal line, where the temporalis muscle inserts, is a helpful landmark. Tong placement should be below this line to allow adequate traction. The tongs are screwed in equally on both sides and a small spring-loaded protuberance will stick out of one side of the tongs when adequate tension is applied. The securing nuts should be tightened to prevent the tongs from loosening. The tongs should be readjusted one day later, again setting the tension spring so that it sticks out approximately one millimeter from the spring-measuring device. This is the only time that the tongs should be readjusted, as further tightening will result in erosion of the tong point through the skull with obvious complications. Patients with skeletal traction should have daily lateral C-spine series, and be X-rayed when weights are changed, to assess vertebral alignment.

Aeromedical Disposition of Spinal Injured Aviation Personnel

Aviation personnel sustaining cervical spinal cord injury or cervical spine column injury would be not physically qualified. Waivers could be considered on an individual basis if the patient was entirely asymptomatic (i.e. without any pain), had full range of motion, and had a normal neurological examination without signs of spinal cord or nerve root damage. Flexion and extension views of the cervical spine should be obtained prior to return to flight status to ensure that there is no excessive range of motion due to ligamentous instability.

In injuries of the thoracic and lumbar region, such as vertebral fractures, aviation personnel

could be returned to flight status following an appropriate grounding period, assuming they were pain-free, had full range of motion, were on no medications, and had a normal neurological examination. In general, individuals with compression fractures of less than 15 percent, or minimal anterior chip fractures, could return to flight status, including flying ejection seat aircraft, following a six-week period of grounding, assuming they were pain-free and had full range of motion. Those with compression fractures of less than 25 percent are grounded for six months for ejection seat aircraft, and three months for nonejection seat aircraft; again, the patient must be pain-free, be normal neurologically, and have full axial range of motion. Patients with compression fractures of less than 50 percent could be returned to nonejection seat aircraft in six months or to ejection seat aircraft in twelve months. Compression fractures over 50 percent, or spinal column damage with posterior element instability or instability on flexion or extension views require neurosurgical or orthopedic for surgical consultation. Such individuals should be grounded for two years prior to return to ejection seat aircraft or grounded for one year prior to return to nonejection seat aircraft. Follow-up evaluations should include thorough neurological and spinal examinations and flexion and extension spinal X-rays to determine any progression of the compression fracture or increase in angulation or presence of instability. Kyphotic curves of over 30 degrees due to compression fractures are likely to increase in angulation and require more frequent follow-up. Nuclear medicine bone scans usually remain hot for a significant period past the healing phase, so may not be an adequate reflection of active vertebral spine pathology.

Common Spine and Peripheral Nerve Problems

Back Pain

Low back pain is one of the most common conditions affecting Americans, costs an estimated \$16 billion a year in lost wages and medical costs, and disables approximately five and one-half million Americans. It is estimated that the lifetime prevalence of low back pain is in 40 percent. Approximately one percent will develop localizing extremity symptoms of radiculopathy (sciatica). Low back pain is clearly an occupational disease and is associated with activities requiring heavy lifting and exposure to vibration. Back pain can be divided into four phases: acute, subacute, chronic, and recurrent. Acute low back pain occurs and resolves within six weeks and accounts for 75 percent of the population of back pain patients. It is estimated that only 20 percent of these patients will have clearly identifiable diagnosis. Subacute back pain resolves within 12 weeks and accounts for about 10 percent of all back pain patients. Chronic and recurrent back pain patients account for 85 percent of the low back pain costs. Chronic low back pain lasts over 12 weeks and accounts for 5 percent of the low back population. Recurrent low back pain, often a disabling condition, accounts for approximately 10 percent of the low back pain patients.

Neurology

Management of Acute Low Back Pain. As with most neurological conditions, the most important thing is to establish whether or not a life-threatening condition is occurring. In the management of acute low back pain, several factors may suggest a possible early presentation of a serious condition. Urgent evaluation should be considered for any patient who is in severe, writhing pain, as this may be the early presentation of an intra-abdominal vascular process, such as a dissecting abdominal aortic aneurysm. Patients who have significant pain at rest may be harboring an infectious or neoplastic process involving the spine or spinal column. Finally, any patient with an evolving neurological deficit such as sacral anesthesia, bowel or bladder incontinence, or progressive sensory motor dysfunction, should be referred to an appropriate center for urgent evaluation.

The mainstay of treatment for acute low back pain is bedrest. Recent studies have shown that two days of bedrest are as effective as seven days of bedrest and result in 45 percent less time lost from work. Generally in a military environment, where a patient is either fit or not fit, it is often not feasible to return a patient to partial work status, so that prolonged bedrest may be indicated in certain occupational rates. During the bedrest phase, a variety of medications can be considered, such as analgesics, muscle relaxants, or nonsteroidal anti-inflammatory medication. Drugs with a high narcotic potential, such as Percocet or Percodan, should be avoided and Valium should not be used as a muscle relaxant as it also has a serious side effect of depression. In some situations, tricyclic antidepressants are effective as analgesics.

Upon resolution of the severe back pain, once the patient is ambulatory, a variety of physical therapy programs should be considered, including strengthening exercises, range of motion, ultrasound, heat and cold packs, and transcutaneous nerve stimulation. In general, gravity traction or bedrest traction is ineffective and can lead to serious secondary complications and should be avoided. Perhaps the most important aspect following improvement of the acute phase, is the back education program, the so-called "low-back school", available in some physical therapy departments. An evaluation by an experienced physician in the workplace may lead to improvements in occupational procedures to reduce recurrence of low back pain. Manipulation may temporarily decrease pain but has no long-lasting benefit. In general, manipulation with rapid changes of direction may actually further weaken spinal ligaments. Soft tissue massage and pressure point techniques may be better tolerated.

Conservative therapy of acute low back pain with sciatica is usually effective, as 50 percent of patients with sciatica will usually resolve their symptoms within six weeks. Those who fail to respond to conservative therapy should be referred for surgical intervention. Patients whose symptoms continue for more than six weeks should undergo further medical evaluation including a complete blood count and sedimentation rate, and consideration for radionuclide bone scan and lumbosacral spine X-rays.

Lumbar Radiography. Indications for spinal X-rays include age over fifty years, history of trauma, history of cancer, unexplained weight loss, pain at rest, illicit IV drug use, steroid use, fever, neurological deficit, and medicolegal considerations. In most cases spinal radiographs are normal or show only nonspecific findings; however, there may be findings on the X-ray which suggest pathology such as:

- Spondylolysis
- Spondylolisthesis
- Disc narrowing
- Schmorl's nodes
- Lumbarization of S-1
- Sacralization of L-5
- Osteophyte formation
- Traction spurs
- Facet sclerosis
- Vertebral sclerosis

Sciatica. Sciatica, or lumbar radiculopathy is manifested by pain, weakness, or sensory loss in a nerve root distribution in the lower extremity. Although, it is commonly due to a herniation of the nucleus pulposus with impingement of the nerve root, it may also be caused by compression of the cauda equina from tumor, abscess, or hemorrhage, or impingement of the nerve root by hypertrophy of the lumbar facets, causing spinal stenosis. Other less common causes include congenital anomalies of the nerve roots, nerve and bone tumors, metastatic disease, and degenerative synovial cysts (Tarlov cysts). Sciatic leg pain may also be caused by extraspinal involvement of the lumbosacral plexus, by tumors or endometriosis involving the pelvic peritoneum, or by compression of the sciatic nerve near the hip due to external compression from a wallet or prolonged sitting, or by localized tumors of the sciatic nerve.

Despite this rather extensive differential of sciatica, the majority of cases are related to a degenerative condition of the lumbar disk. The most likely levels involved are the L4-L5 disk causing an L-5 radiculopathy, or the L5-S1 disk causing an S-1 radiculopathy. The L-5 radiculopathy causes weakness of the dorsiflexors and evertors of the foot and numbness and pain over the lateral aspect of the leg and ankle and dorsal aspect of the foot. The S-1 radiculopathy results in weakness of the ankle plantar flexors and hamstrings and numbness and pain over the lateral aspect of the sole of the foot.

Another clinical entity is lumbar neurogenic claudication, usually due to lumbar spinal stenosis. Narrowing of the central canal and lateral aspect of the spinal column results in low

Neurology

back pain and bilateral leg pain primarily while ambulating. This condition often mimics vascular insufficiency of the lower extremities. Lumbar neurogenic claudication, seen with degenerative spine disease, is characterized by the lack of signs of vascular insufficiency (atrophic skin and diminished distal pulses). Neurogenic pain usually resolves after resting for 15 or 30 minutes, whereas pain due to vascular insufficiency, which is usually confined to the calves, resolves immediately with rest. Persons with lumbar spinal stenosis walk in the flexed position because in the extended position, the central canal is compressed, resulting in prominent pain and weakness.

Evaluation of the Lumbar Spine and Lower Extremity Nerve Roots. Examination of the lumbar spine should include physical examination of the spinous processes and alignment, looking for excessive lordosis, scoliosis, and vascular skin lesions (birthmarks). Examination of the extremities should provide assessment of muscle atrophy. Evaluation of the spine should include range of motion (extension, flexion, lateral flexion, and lateral rotation). Extreme range of motion can be ascertained by having the patient bend and touch his toes. Examination of the muscle groups of the lower extremity should include individual muscle group testing of the hip flexors, extensors, abductors, and adductors; knee flexors and extensors; ankle dorsiflexors, plantar flexors, invertors and evertors; and toe dorsiflexors and plantar flexors. Muscle strength may also be tested by having the patient heel walk, toe walk, hop on one foot, duck walk, and do one-legged deep knee bends. A spine evaluation form is enclosed as APPENDIX 7-H.

Provocative maneuvers may detect lumbar disc disease or joint pathology. The straight-leg raising maneuver is conducted with the patient lying supine. The leg is slowly elevated and if pain is reproduced in the back of leg, the angle the leg is raised to produce pain should be noted. Leseque's maneuver is a modification of the straight leg raising sign. The leg is raised to a level just prior to eliciting backpain or leg pain, then Leseque's maneuver (dorsiflexion of the foot) is performed, and development of leg or back symptoms are noted. Both these are signs of lumbar disc disease. The femoral stretch maneuver starts with the patient in the prone position and the leg extended at the knee. The hip is gradually extended posteriorly. This stretches the lumbar L-4 nerve root and reproduction of symptoms may be indicative of lumbar disk disease at the L3-L4 level. A maneuver to detect musculoskeletal problems at the hip is Patrick's sign or the FABERE maneuver, which stands for hip flexion, abduction, external rotation and extension. This maneuver is designed to reproduce pain of a musculoskeletal nature.

Sensory examination of the lower extremities should include light touch and pinprick. If bowel or bladder symptoms are present, test sensation around the anus and perineal region. Reflex examination should include the quadriceps (knee jerk) and gastrocnemius (ankle jerk) reflex. The cremasteric and bulbocavernous reflex should be tested if the patient has bowel or

bladder symptoms. Patients who fail to respond to conservative therapy and have signs of radicular symptoms over six weeks should be referred for neurological or orthopedic evaluation. Patients with low back pain whose symptoms are unremitting or severe, or have profound weakness should be evaluated on an urgent basis, particularly if there are indications of a neoplastic or infectious process. Chronic low back pain may occur in a variety of hereditary and metabolic conditions, such as spondylolysis, osteochondrosis (Schuermann's disease), osteoporosis, ankylosing spondylitis, fibromyalgia, idiopathic sclerosis, Paget's disease, and vertebral body fusion (Klippel-Feil syndrome).

Neck Pain and Upper Extremity Radioculopathy

A variety of conditions may cause pain in the neck or upper extremities. Perhaps the most common is cervical spondylosis or disc disease of the cervical region. The most common disc syndrome in the cervical region is a C-6 radiculopathy, which causes weakness of the proximal upper extremity (deltoid, biceps, and wrist flexors), diminished biceps and brachioradialis reflex, numbness over the thumb and index finger, and pain in the arm radiating to the thumb and index finger. The next most common disc syndrome is a C-7 radiculopathy, which causes weakness of the triceps and wrist extensors, numbness of the middle finger and diminished triceps reflex. C-8 radiculopathy causes pain in the arm radiating to the ring and little finger and weakness of the hand intrinsic muscles, primarily finger flexors. Cervical disc disease is managed similar to lumbar disc disease, with bedrest and analgesics as necessary, and physical therapy after the acute phase.

Peripheral Neuropathies

Peripheral neuropathies are due to a variety of etiologies, but in the young active-duty military population, they are most commonly due to trauma or chronic entrapment syndromes. In the older age groups, diabetes and alcohol are possibilities, as well as inflammatory peripheral neuropathies. Toxic neuropathies can occur from exposure to a variety of solvents and chemicals used in aviation maintenance and ordinance. Hereditary neuropathies are quite common, and may be cumulative with the effects of other neuropathies. Peripheral nerves may be injured by a variety of physical means, including percussion, traction, compression, ischemia, cold, or by transection.

An injury classification of peripheral nerve injuries is based on anatomic damage. The most common injury type of peripheral nerves is neuropraxia, which is a localized (segmental) demyelination. This type of nerve injury will resolve within hours to days. The next injury type is axonotmesis, which is damage to the axon cylinders of the nerve. Damage of this type requires

a longer period for recovery and this type of nerve injury may take months to recover. The last, and worst type of injury is neurontomesis, which is a disruption of both the axon cylinder and myelin. It is commonly due to laceration, where the nerve is no longer in physical continuity with the other portion of the nerve.

Common Entrapment Neuropathy Syndromes

Suprascapular Neuropathy. This neuropathy is due to entrapment of the suprascapular nerve at the shoulder. It is also called rucksack palsy, which is due to the straps of a heavy rucksack compressing the suprascapular nerve. This is a pure motor nerve disorder and causes weakness of the external rotators of the arm and the shoulder abductors.

Median Nerve Entrapment Neuropathies.

1. *Pronator Teres Syndrome.* The median nerve may become entrapped at several locations. Entrapment of the median nerve may occur in the antecubital fossa (medial elbow), where the median nerve passes between the pronator teres muscle. The pronator teres syndrome may be seen in a variety of conditions. It may affect weight lifters who overdevelop their forearm muscles, or in pilots who roll their flightsuits over the forearms. It causes weakness of the wrist and finger flexors. Entrapment of the median nerve proximally causes weakness of the hand flexors and of the first and second fingers and thumb, causing the appearance of the papal hand sign.

2. *Anterior Interosseous Nerve Syndrome.* The median nerve may become entrapped in the lateral forearm. In the anterior interosseous nerve syndrome, or honeymoon palsy, may occur when the spouse's head rests on the forearm overnight and resulting in weakness of the thumb and index finger flexors and pronator quadratus. This results in difficulty with pincher movements of the thumb and index fingers.

3. *Carpel Tunnel Syndrome.* The most common entrapment neuropathy, the carpal tunnel syndrome, results from entrapment of the distal median nerve in the wrist as it passes through the carpal tunnel. This causes weakness of the LOAF muscles (lumbricals, opponens, abductor and flexor of the thumb). This results in atrophy of the thenar eminence. Because of weakness of the thumb muscles, the thumb falls back into the planes of the hand, causing the "simian hand" or monkey hand. Tapping the median nerve over the wrist may cause an electrical sensation, and is characteristic of carpal tunnel syndrome (Tinel's sign). Symptoms may also be reproduced by hyperflexing the wrist (Phalen's sign).

Ulnar Entrapment Neuropathies. The ulnar nerve may be entrapped above the elbow by the ligament of Struthers, at the elbow in the olecrenon groove, and below the elbow in the cubital

tunnel. Ulnar entrapment at the elbow causes a sensory loss of the little finger and the lateral aspect of the ring finger and weakness and atrophy of the hypothenar eminence, resulting in the "claw hand" deformity. Percussing the nerve above, at, or below the elbow may cause electrical sensations or pain, which is diagnostic of entrapment at that region (Tinel's sign). Entrapment of the ulnar nerve at the elbow is very common with trauma, particularly fractures of the elbow, athletic injuries, or chronic compression over the ulnar groove from pressure to the elbow. The ulnar nerve may also be entrapped in the wrist in Guyon's canal. The ulnar nerve is a pure motor nerve without any sensory component, so entrapment would cause only weakness of the hypothenar muscles. It also results in weakness and atrophy of the thumb dorsal interosseous muscle, the large muscle between the thumb and index finger over the back of the hand. Weakness of the thumb abducting against the index finger is called of Froment's sign. Injury to the wrist, from fractures or chronic pressure (use of power tools), may result in median (more commonly) or ulnar nerve compression at the wrist.

Radial Nerve Palsies

1. *Radial Nerve Entrapment.* The radial nerve may undergo damage in the arm at the spiral groove of the humerus causing paralysis of the wrist extensors but sparing the triceps. This syndrome is also called Saturday night palsy, crutch palsy, or honeymoon palsy and is due to a pressure over the spiral groove compressing the radial nerve and causing subsequent weakness. This may occur from falling asleep with the arm draped over a chair following a heavy night of partying or having a crutch incorrectly fitted and putting pressure on the humerus of the arm rather than in the axilla, or from having one's spouse fall asleep with the head pressing against the humerus.

2. *Handcuff Palsy.* The sensory radial nerve can be compressed over the dorsal aspect of the wrist, in the region of the anatomic snuff box. This causes a pure sensory syndrome with numbness over the dorsal aspect of the thumb. Sensory radial palsy is also called handcuff palsy, because it occurs if handcuffs are applied too tightly.

Thoracic Outlet Syndrome. Another condition affecting the upper extremity is the thoracic outlet syndrome which is due to compression of the lower portion of the brachial plexus or the thoracic vascular system. It may result in motor and sensory symptoms in the hand. Provocative maneuvers that reproduce the thoracic outlet syndrome include the costoclavicular maneuver (pulling the shoulders back) and Adson's sign (abducting, and externally rotating the arms over the head, then changing head position). Distal radial pulses should also be palpated as this may be a vascular insufficiency problem.

Neurology

Lateral Femoral Cutaneous Neuropathy. The lateral femoral cutaneous nerve entrapment (neuralgia paresthetica) is due to nerve entrapment in the inguinal ligament. This nerve innervates the lateral aspect of the thigh and may cause numbness or burning over the lateral thigh. It may be seen in obese people, diabetics, and also may result from a tight-fitting torso harness.

Sciatic Nerve Entrapment. Sciatic nerve entrapment, called “wallet sciatica” or “toilet seat neuritis”, occurs following prolonged sitting, particularly on hard surfaces where the sciatic nerve is compressed, resulting in weakness of the plantar and dorsiflexors of the feet and toes and numbness of the entire foot.

Peroneal Neuropathy. The peroneal nerve may be entrapped at the fibular head, either due to trauma or compression (prolonged leg crossing) and results in weakness of the dorsiflexor of the ankle and toes, foot evertors, and numbness of the dorsal aspect of the foot. This syndrome may be confused with an L-5 radiculopathy but without back pain.

Tarsal Tunnel Syndrome. A branch of the posterior tibial nerve may be compressed in the tarsal tunnel in the foot due to tight-fitting boots or prolonged running.

Morton’s Neuroma. Claw foot or Morton’s neuralgia may occur with compression of the digital nerves of the toes. It may be quite painful and may respond to padding between the toes.

Aviation Disposition of Spine and Nerve Conditions

Entrapment neuropathes usually resolve following relief of the offending compression but may require several weeks or even months to resolve fully. Sensory symptoms such as numbness often do not resolve. Patients should be without neurological deficit and be pain-free prior to return to flight status.

Patients with back or neck conditions that have not been surgically treated should be pain free and without substantial neurological deficit prior to returning to flight status. The flyer’s clinical syndrome would have to be viewed with respect to his aviation duties. Subtle weakness or numbness may affect flight performance. Air combat maneuvering places a significant strain on the cervical region and may prolong recovery or further aggravate a radiculopathy. Undesignated aviation personnel who are manifesting low back pain or radiculopathy could be expected to have further problems from the physical stress of naval aviation, and would generally be NPQ with waiver not recommended.

U.S. Naval Flight Surgeon's Manual

Patients who have undergone cervical or lumbar laminectomy would be NPQ and waived to Class II or Service Group II after six months of grounding from the date of surgery or resolution of neurological deficits. After 12 months, waivers would be considered for Service Group I or II. Undesignated personnel who have undergone spine surgery are not good candidates for flight training due to the chance of recurrence and waivers are generally not recommended.

Scoliosis over 25 degrees is considered disqualifying (CD) for flight duties. Scoliosis over 20 degrees should be evaluated by an orthopedic specialist.

Kyphosis over 20 degrees should be evaluated by an orthopedic specialist and is disqualifying if over 45 degrees.

Spondylolysis (Pars interarticularis defect) is disqualifying with no waiver for nondesignated personnel but may be waived if asymptomatic in designated personnel.

Central Nervous System Infections

Introduction

A variety of organisms may infect the central nervous system, often with life threatening consequences. CNS infection may result from viral, bacterial, fungal, protozoal, or rickettsial organisms. Before central nervous system infection can occur the organism must gain access by penetrating extra neural structures, overcome local defense mechanisms, cross the blood brain barrier, then persist and reproduce despite host defenses. Organisms may gain access via direct penetration of the skin (following trauma or surgical procedures), spread from adjacent cranial sinus or bone infection, uptake by the peripheral nerve axonal transport system from wounds (rabies, tetanus, or Simian B monkey virus), or by directly penetrating the olfactory mucosa. Most organisms gain access to the central nervous system via hematogenous (blood-borne) spread.

Acute Bacterial Meningitis

The most common bacterial infection of the central nervous system is acute pyogenic meningitis, which is a life threatening condition. Bacterial meningitis was first described in 1805 and the first therapy occurred with the advent of lumbar puncture. Intrathecal antiserum was injected via lumbar puncture in 1913 by Flexner and this reduced the mortality of bacterial meningitis from 90 to 30 percent. With the advent of antibiotics in the 1930s, mortality rate dropped to 14 percent, however despite the improved antibiotics available today, overall mortality rate

Neurology

for acute pyogenic meningitis remains about the same. Pathogenesis of meningitis depends on (1) a defect in the blood brain barrier (2) bacterial virulence factors and (3) host defense factors. The type of micro-organism in meningitis is related to patient age and the presence and nature of underlying medical conditions or predisposing factors in the host. Bacterial meningitis is a dynamic process, involving central nervous system penetration, then unimpeded bacterial multiplication in the spinal fluid, followed by a secondary bacteremia, and finally a continuous reseeding of the intracranial spaces. Meningitis may alter the blood brain barrier permeability and result in other sequela such as venous thrombosis and brain edema (vasogenic, cytotoxic, and interstitial). Bacteria have developed factors which enhance their survival and facilitate penetration into the nervous system. Perhaps the most striking example is the protein coat of the bacteria capsule which is present in the four major bacterial pathogens: *S. pneumoniae*, *H. influenzae*, *N. meningitidis*, and *E. coli*. This encapsulation antagonizes phagocytosis by the white blood cells.

In the early infant and neonatal period the primary bacteria involved in meningitis are the gram negative rods (*Escherichia coli*), and group B streptococcus. In infants over three months of age, *Hemophilus influenzae* is the leading cause. Maternal placentally transferred antibodies protect the infant from *H. influenzae* in the immediate post natal period. After three years of age, *H. flu* drops in incidence, and *Streptococcus pneumoniae* and *Neisseria meningitidis* become the most frequent pathogens. A variety of medical and surgical conditions may predispose the patient to bacterial meningitis. An immunocompromised state or debilitation, such as chronic alcoholism, may predispose a patient to *Hemophilus influenzae*, *Streptococcus pneumoniae*, and *Listeria monocytogenes*. Burn patients are more susceptible to *Pseudomonas*. Patients with splenic dysfunction or sickle cell disease are predisposed to *Streptococcus pneumoniae* and *Hemophilus influenzae*. Chronic sinusitis may predispose the patient to anaerobic *Streptococcus*, *S. pneumoniae*, and gram negative rods, such as *Bacteroides fragilis*. Penetration of the skin and dura following post traumatic spinal fluid leak or neurosurgical procedures, predisposes a patient to *S. pneumoniae*, *Staphylococcus aureus*, and gram negative meningitis. A patient with subacute bacterial endocarditis may develop *Staphylococcus epidermidis* meningitis.

Bacterial meningitis in a patient with an underlying medical condition will have a more profound effect on central nervous system function, often with decreased level of consciousness. Septicemia, overwhelming fever, and deteriorating vital signs are common manifestations of the big three bacterial meningitis organisms: *S. pneumoniae*, *H. influenzae*, *N. meningitidis*. Rash and petechiae are common in *N. meningitidis* but may also present in *S. aureus*, *Hemophilus influenzae*, *Streptococcus pneumoniae*, or viral meningitis (Coxsackie Echo 9). Signs of meningeal irritation, such as nuchal rigidity, fever, photophobia, headache, and pain on eye movement, may not be present in a infant or child, or in an immunocompromised or elderly individual.

An early diagnosis is crucial and the diagnostic procedure of choice is the lumbar puncture and spinal fluid analysis. It is important not to delay antibiotic therapy while waiting for a lumbar puncture, or if indicated, a CT scan to be performed. Cerebrospinal fluid findings in bacterial meningitis include (1) an elevated white blood cell (WBC) count, particularly > 1000 WBCs/ cubic mm and $> 50\%$ polymorphonuclear neutrophils (PMNs), (2) an elevated spinal fluid protein $> 50\text{mg}\%$ or (3) a glucose level $< 2/3$ of simultaneously obtained serum glucose level. Early identification of the responsible organism will aid in the appropriate selection of antibiotics. Bacterial culture and sensitivity assay is essential for guiding antibiotic therapy. The CSF gram stain may provide an immediate clue to the etiology while the culture and sensitivities are pending. Counterimmune electrophoresis (CIE) provides early identification of the common bacterial pathogens (*H. flu.*, *N. meningitidis*, and *S. pneumococcus*) within hours. Serum, urine, and spinal fluid CIE levels should be obtained. Failure to grow or isolate an organism may be due to: 1) prior antibiotic use (often as self treatment for a presumed cold), 2) meningitis due to a non-bacterial infection (fungal, viral, protozoal, Rickettsial), or an unsuspected bacterial infection (Lyme disease, tuberculosis, or syphilis), 3) the meningitis is due to a parameningeal infection (subdural empyema or brain abscess). Every effort should be made to diagnose these conditions, particularly if the patient deteriorates or fails to improve after the administration of broad spectrum antibiotics. If a bacterial meningeal infection is suspected it is crucial that antibiotic administration not be delayed while diagnostic tests are performed. In severe life threatening sepsis and meningitis, with cerebral edema, the patient may need intubation, intracranial pressure monitoring, and treatment of intracranial hypertension. Hyperthermia should be aggressively treated.

Treatment of Bacterial Meningitis. Community acquired bacterial meningitis in a previously healthy adult will usually respond to penicillin. With the extensive use of antibiotics, bacteria have become increasingly resistant to commonly administered antibiotics. Penicillin resistance in *S. pneumonia* and *Neisseria* is increasing as a result of a viral plasmid transmitted factor which carries the enzyme, beta-lactamase, which disrupts the antibiotic structure, rendering it ineffective. In *H. influenza* ampicillin resistance is present in approximately 25 percent of cases and 1 percent are resistant to chloramphenicol. The most appropriate antibiotic is determined by the bacterial sensitivity to antibiotic minimum inhibitory concentrations of less than 0.1 MG/ML. For meningitis of unknown etiology broad spectrum antibiotic coverage is indicated. IV antibiotic therapy should continue for at least 7 to 10 days following the return of normal temperature and clinical stability. Repeat spinal fluid analysis may be indicated within 2 to 3 days if the patient deteriorates. Followup spinal fluid analysis after completion of an antibiotic course may also be indicated if the patient relapses.

Third generation cephalosporins are becoming increasingly popular because of their broad coverage and the emergence of penicillin resistant organisms. Gram negative meningitis may be

Neurology

found in septic urinary tract infections, penetrating head injury, or following neurosurgical procedures. Third generation cephalosporins in combination with aminoglycosides, are effective against gram negative meningitis. Intrathecal antibiotics are occasionally indicated for gram negative meningitis, such as hospital acquired pseudomonas in an elderly debilitated patient. Patients with neurosurgical appliances (shunts), should have the shunt tapped for spinal fluid analysis. If CSF infection is present, removal of the shunt may be necessary, as a foreign body tends to worsen the clinical situation. Patients allergic to penicillin may require erythromycin, cloramphenicol, or a cephalosporin.

Prophylactic treatment with rifampin is indicated for Neisseria meningitis for all close contacts of the index case, such as household members, workers, shipmates, or squadron mates who are in close contact, or close contacts in infant day care centers. Casual contacts do not need to be treated. The secondary attack rate for close contacts is about 1 percent and is higher for younger children. All contacts should be treated simultaneously. Throat cultures are not effective in deciding who should receive prophylaxis. In adults, rifampin is given on a dose of 600 mg q12 hours for a total of four doses. Minocycline may be effective but causes substantial vestibular reactions. Chemoprophylaxis for Hemophilus influenza exposure depends on the age of close household contacts. If the close contacts are children less than four years of age in the household of the index case then all household members should receive rifampin (20mg/kg/d dose for 4 days). Infants in day care centers may be considered close contacts in some situations and therapy should be started as soon as possible within seven days of discovery of the index case. After seven days the use of chemoprophylaxis with rifampin has not been shown to be effective. If the index case and close contacts are over four years of age then chemoprophylaxis is not indicated.

Parameningeal Infections

Sinusitis may erode through the dura and may result in meningitis, osteomyelitis, epidural abscess, subdural empyema, subdural abscess, brain abscess, or venous sinus thrombosis. The most common organisms are S.pneumonia, Streptococcus, Staphylococcus, and H.influenza. Parameningeal infection is a life threatening condition and may be more serious than acute bacterial meningitis. Depending on which sinuses are involved, there may be a variety of clinical presentations. Mastoid sinusitis and involvement of the lateral portion of the petrous portion of the temporal bone may result in a brain abscess with focal neurologic deficits, seizures, and signs of increased intracranial pressure (headache, vomiting, and decreased level of consciousness). Sphenoid sinusitis may present with septic thrombophlebitis and cavernous sinus thrombosis, which may involve the optic nerve (visual loss), the trigeminal nerve (facial numbness), or the oculomotor nerves (double vision). Frontal sinusitis and skull osteomyelitis may cause Pott's

Puffy Tumor, resulting in a unilateral or occasionally bilateral swelling of the orbital region due to a subperiosteal abscess. Occasionally the infection extends into the epidural region. A dural tear from previous head trauma, may result in a subdural empyema, resulting in rapidly progressing neurologic deterioration, meningeal signs, focal neurologic deficits, and seizures. Treatment is dependent on the responsible organism. The organism usually comes from the adjacent sinus, and is often penicillin resistant *S. aureus* or a gram negative rod. Subdural empyema requires prolonged (2-4 weeks) IV therapy with a penicillinase resistant penicillin, such as nafcillin (12 gm per day), or chloramphenicol, or an aminoglycoside. An abscess in the subdural or intracranial space should be surgically treated, to identify the organism, and institute appropriate antibiotic therapy, and to reduce the mass effect.

Nonbacterial Infections

Nonbacterial organisms may involve the sinuses, causing acute neurologic deterioration. In diabetics and leukemics, molds, such as *Rhizopus* and *Mucormycosis*, may result in a fulminant meningoencephalitis, progressive neurologic deterioration, cranial nerve palsies, seizures, and infarction. The therapy for fungal brain infection is IV amphotericin B; and, mortality is very high. Malignant otitis externa is seen in diabetics who develop *Pseudomonas* cellulitis, which spreads intracranially, resulting in meningitis or meningoencephalitis. The protozoan *Naegleria* may cause a fulminant and usually fatal meningoencephalitis following swimming in infected fresh water. Treatment with amphotericin B and miconazole is a last ditch effort. Spinal fluid analysis in *Naegleria* meningoencephalitis reveals a polymorphonuclear pleocytosis, occasional eosinophils, and mobile ameba.

Systemic fungal infections are common complications of acquired immune deficiency syndrome (AIDS). Four drugs available for treating systemic fungal infections are Amphotericin B, flucytosine, miconazole, and ketoconazole. Rickettsial infections, such as Rocky Mountain Spotted Fever and scrub typhus are treated with a tetracycline or chloramphenicol. Lyme disease, due to a bacterial spirochete, is effectively treated with tetracycline or penicillin.

Cerebral malaria is a life threatening complication of infection with *Plasmodium falciparum*. Cerebral malaria is characterized by profound mental obtundation, psychosis, seizures, and hyperreflexia. The cerebral spinal fluid shows an elevation of pressure and protein but no pleocytosis. Fourteen days following the mosquito bite the patient develops prodromal chills, spiking fever, which progresses to intense headache and muscle pain. The pathogenesis of cerebral malaria is a mechanical distortion of the blood vessels due to rapid proliferation of the parasites, causing stagnation of blood, or possibly some toxic effect on the vascular endothelium or an immune complex vasculitis. Treatment of cerebral malaria is with intravenous quinine.

Glucocorticosteroids, used to treat cerebral edema, have been shown to prolong the coma and increase complications without affecting mortality and now appear to be contraindicated in cerebral malaria.

Viral CNS Infections

Viral infections of the nervous system produce three classic clinical syndromes: (1) meningitis, (2) encephalitis, or (3) poliomyelitis. Viral meningitis produces a milder clinical syndrome than in bacterial meningitis. The patient has a mild headache, less prominent meningeal irritation, and spinal fluid analysis reveals an elevated white blood cell count that is predominantly lymphocytic. The spinal fluid protein usually remains within normal limits and the spinal fluid glucose remains within 2/3rds of serum glucose. Viral encephalitis is divided into two categories, infectious encephalitis, due to the direct effects of the virus, and parainfectious encephalitis, due to associated reactions in the immune system affecting the central nervous system. Para-infectious complications include a perivenous inflammatory response and leucoencephalitis. Other post infectious syndromes include cerebellar ataxia, and peripheral nerve disorders, such as Guillain-Barre syndrome. Viral encephalitis is classified as (1) arbovirus (arthropod borne), (2) enteroviruses, (3) childhood viruses, (4) other.

The most common sporadic (nonepidemic) viral encephalitis is herpes simplex encephalitis. This form of viral (HSV) encephalitis may result from either exogenous infection (entrance via olfactory mucosa) or from dormant (latent) virus residing inside the host nervous system (trigeminal sensory ganglion). The characteristic clinical course for herpes simplex encephalitis is an acute or subacute syndrome of headache, fever, behavioral disturbance, seizures and progressive cortical dysfunction. Herpes simplex encephalitis causes a necrotizing hemorrhagic encephalitis, primarily involving the frontal, temporal, and limbic lobes. Spinal fluid analysis reveals red blood cells due to brain hemorrhage and necrosis. Oligoclonal bands on immunoglobulin protein electrophoresis may be present in the spinal fluid. EEG will reveal periodic spike and slow waves over the temporal lobes and the CT scan reveals bitemporal necrosis and hemorrhage of the frontal and temporal region. This mass effect is usually present within the first five days of onset. Temporal lobe biopsy is the diagnosis of choice and reveals characteristic intranuclear inclusion bodies. Treatment of HSV encephalitis is with intravenous Acyclovir.

Epidemic encephalitis is usually related to vector spread, such as insects. The most common arthropod borne virus is St. Louis encephalitis. St. Louis encephalitis may present with seizures, tremor, myoclonus, vertigo, or electrolyte imbalance. Arboviruses tend to occur during the summer months. The most fulminant of the Arboviruses is Eastern Equine Encephalitis, which affects horses and pheasants prior to spread in man. Arboviruses tend to affect children more than

adults. Encephalitis due to mumps and lymphochoriocytic meningitis occur primarily in the winter months. Except for herpes virus there is no specific antiviral therapy other than symptomatic treatment of fever and anticonvulsant therapy if seizures are present.

References and Bibliography

General

- Adams, R.D. & Victor, M. *Principles of Neurology* (3rd Ed.). New York: McGraw-Hill, 1985.
- American Medical Association. Neurological and neurosurgical conditions associated with aviation safety. *Archives of Neurology*, (Special issue), 36 (12), 1979, 36 (12) 0
- Asbury, A.K., McKhann, G.M., & McDonald, W.I., *Diseases of the nervous system* (Vol I & II). W.B. Saunders, 1986.
- Mayo Clinic. *Clinical examinations in neurology*. Philadelphia: W.B. Saunders, 1976.
- Flight Surgeon Quick Reference. Naval Aerospace Medical Institute Press, 1988.

Headache

- Anderson, C.D., & Franks, R.D. Migraine and tension headache - Is there a physiological difference? *Headache*, 1981, 21, 63-71.
- Appenzeller, O. Altitude headache. *Headache*, 1972, 12, 126-129.
- Bartleson, J.D. Transient and persistent neurological manifestations of migraine. *Stroke*, Mar-Apr 1984, 15, 383-386.
- Freidman, A.P., Finley, K.H., Graham, J.R., et al. Classification of headache. *Journal of the American Medical Association*, 1962, 179, 717.
- Kunkel, R.S. Acephalgic migraine. *Headache*, 1986, 26, 198-201.
- Lance, J.W. Headache. *Annals of Neurology*, 1981, 10, 1-10.
- Moskowitz, M.A. The neurobiology of vasculz head pain. *Annals of Neurology*, 1984, 16, 157-168.
- Riley, T.L. Muscle contraction Headache. *Neurologic Clinics*, 1983, 1, 489-500.
- Wolff, H.G. *Wolff's headache and other head pain* (4th ed.). Dalessio, D.J. (Ed). New York: Oxford University Press, 1980.

Vertigo

- Baloh, R.W., & Honrubia, V.H. *Clinical neurophysiology of the vestibular system*. Philadelphia: F.A. Davis, 1979.
- Baloh, R.W. *Dizziness, hearing loss and tinnitus: The essentials of neurotology*. Philadelphia: F.A. Davis, 1984.
- Baloh, R.W. Honrubia, V., & Jacobson, K. Benign positional vertigo: Clinical and oculographic features in 240 cases. *Neurology*, 1987, 37, 371-378.
- Brandt, T., & Daroff, R.B. The multisensory physiological and pathological vertigo syndromes. *Annals of Neurology*, 1980, 7, 195-203.

Neurology

Brandt, T., & Daroff, R.B. Physical therapy for benign paroxysmal positional vertigo. *Archives of Otolaryngology*. 1980.

Drachman, D.A., & Hart, C.W. An approach to the dizzy patient. *Neurology*, 1972, 22, 323.

Halmagyi, G.M., & Gresty, M.A. Clinical signs of visual-vestibular interaction. *Journal of Neurology, Neurosurgery, and Psychiatry*, 1979, 42, 934-939.

Syncope

Blackburn, L.H. The evaluation of physiological syncope in aviation personnel. *Aerospace Medicine*. 1964, 35, 1212-1216.

Buley, L.E. Incidence, causes and results of airline pilot incapacitation while on duty. *Aerospace Medicine*, 1969, 40, 64-69.

Day, S.C., Cook, E.F., Funkenstein, H., et al. Evaluation and outcome of emergency room patients with transient loss of consciousness. *American Journal of Medicine*, 1982, 73, 15-23.

Kapoor, W.N., Karpf, M., Maher, Y., et al. Syncope of unknown origin: The need for a more cost-effective approach to its diagnostic evaluation. *Journal of the American Medical Association*, 1982, 247, 2687-2691.

Kapoor, W.N., Karpf, M., Wieand, S., et al. A prospective evaluation and followup of patients with syncope. *New England Journal of Medicine*, 1983, 309, 197-204.

Rayman, R.B. In-flight loss of consciousness, *Aerospace Medicine*, 1973, 44, 679-681.

Rayman, R.B., McNaughton G.B. Sudden incapacitation: USAF experience, 1970-1980. *Aviation Space and Environmental Medicine*, 1983, 54, 161-164.

Rayman, R.B. Sudden incapacitation in flight 1 Jan 1966 - 30 Nov 1971. *Aerospace Medicine*, 1973, 44, 953-955.

Ziegler, D.K., Lin J, Bayer, W.L. Convulsive syncope: Relationship to cerebral ischemia. *Transactions of the American Neurological Association*, 1978, 103, 150-154.

Spine Trauma

Charlton, O.P., Gehweiler, J.A., Jr., Martinez, S. Roentgenographic evaluation of cervical spine trauma. *Journal of the American Medical Association*, 1979, 242, 1073-1075.

Cloward, R.B. Acute cervical spine injuries. *CIBA Clinical Symposia*, 1980, 32 (1), 1-32.

Crooks, L.M., Long term effects of ejecting from aircraft, *Aerospace Medicine*, 1970, 41, 803-804.

Ewing, C.L., King, A.I., & Prasad, P. Structural considerations of the human vertebral column under +Gz impact acceleration. *Journal of Aircraft*, 1972, 9, 84-90.

Gehweiler, J.A., Osborne, R.L., & Becker, F. *The radiology of vertebral trauma*. Philadelphia: WB Saunders, 1980.

Panjabi, M.M., & White, A.A. Basic biomechanics of the spine. *Neurosurgery*, 1980, 7, 76-93.

Rothman, R.H., & Simeone, F.A. *The spine* (Vol I & II). Philadelphia: WB Sanders, 1982.

Smelsey, S.O. Study of pilots who have made multiple ejections. *Aerospace Medicine*, 1970, 41, 563-566.

U.S. Naval Flight Surgeon's Manual

Spine and Peripheral Nerve

Dawson, D.M., Hallett, M., & Millender, L.H. *Entrapment neuropathies*. Boston: Little, Brown, 1983.

Dyck, P. J., Thomas, P.K., Lambert, E.H., & Bunge, R., (Eds). *Peripheral neuropathy*. Philadelphia: WB Saunders, 1984.

Frymoyer, J.W. Back pain and sciatica. *New England Journal of Medicine*, 1988, *318*, 291-300.

Gilliatt, R.W. Physical injury to peripheral nerves. *Mayo Clinic Proceedings*, 1981, *56*, 361-370.

Leech, J.J., Klara, P.M., Gunby, E.N. Management of low back pain in the military population. *Military Medicine*, 1988, *153* (10), 501-505.

Medical Research Council. Aids to the examination of the peripheral nervous system (Memorandum No. 45). London: Her Majesty's Stationary Office.

Spencer, P.S., & Schaumburg, H.H. (Eds). *Experimental and clinical neurotoxicology*. Baltimore: William & Wilkins, 1980.

Sunderland, S. *Nerves and nerve injuries*. Baltimore: Williams & Wilkins, 1978.

APPENDIX 7-A

Cognitive Capacity Screening Examination

Mini Mental Status Exam

Examiner

Date

Instructions: Check items answered correctly. Write incorrect or unusual answers in space provided. If necessary, urge patient to complete task. Introduction to patient: "I would like to ask you a few questions. Some you will find very easy and others may be very hard. Just do your best."

Trial Date/Time:

1. What day of the week is this?

2. What month?

3. What day of month?

4. What year?

5. What place is this?

6. Repeat the numbers 8 7 2.

7. Say them backwards.

8. Repeat the numbers 6 3 7 1.

9. Remember these numbers 6 9 4. Count 1 through 10 out loud, then repeat the numbers (6 9 4) if help needed use numbers 5 7 3.

Mini Mental Status Exam (Continued)

10. Remember these numbers 8 1 4 3. Count 1 through 10 out loud, then repeat the number (8 1 4 3). _____

11. Beginning with Sunday, say the days of the week backward. _____

12. 9 + 3 is _____

13. Add 6 (to the previous answer or "to 12"). _____

14. Take away 5 ("from 18"). Repeat these words after me and remember them. I will ask for them later: HAT, CAR, TREE, TWENTY-SIX. _____

Name _____ Rank _____ SSN _____

15. The opposite of fast is slow. The opposite of up is _____

16. The opposite of large is _____

17. The opposite of hard is _____

18. An orange and a banana are both fruit. Red and blue are both _____

19. A penny and a dime are both _____

20. What were those words I asked you to remember? (HAT) _____

21. (CAR) _____

22. (TREE) _____

Neurology

(Mini Mental Status Exam continued)

23. (TWENTY-SIX) _____
24. Take away 7 from 100, then take away 7 from
what is left and keep going: 100-7 is (93) _____
25. Minus 7 (86) _____
26. Minus 7 (79) _____
27. Minus 7 (72) _____
28. Minus 7 (65) _____
29. Minus 7 (58) _____
30. Minus 7 (51) _____
- TOTAL CORRECT (Maximum score 30) _____

Patient's occupation (previous, if not employed) _____
Education _____ Age _____. Estimated intelligence (based on
Education, occupation, and history, not on test score):

Below average Average, Above average _____

Patient was: Cooperative _____ Uncooperative _____ Depressed _____
Lethargic _____ Other _____

IF PATIENT'S SCORE IS LESS THAN 20, THE EXISTENCE OF DIMINISHED
COGNITIVE CAPACITY IS PRESENT. THEREFORE, AN ORGANIC MENTAL SYN-
DROME SHOULD BE SUSPECTED AND THE INFORMATION ON THE FOLLOWING
PAGE OBTAINED.

Name _____ Rank _____ SSN _____

Temp. _____ BUN _____ Drug Screen _____

(Mini Mental Status Exam continued)

B.P. _____ Glu _____ Heavy Metal _____
HR _____ PO2 _____ ETOH Level _____
Hct _____ PCO2 _____
WBC _____ CA _____ Clinical History _____
Na _____ MG _____
K _____ Medical History: _____
LFT/TFT _____
HCO3 _____ Drugs/Medication: _____
EEG _____ Focal neurological signs: _____
ECG _____

Signature & Title

Date

Patients Identification:

NAME:

SSN:

RANK:

DUTY STATION:

U.S. Naval Flight Surgeon's Manual

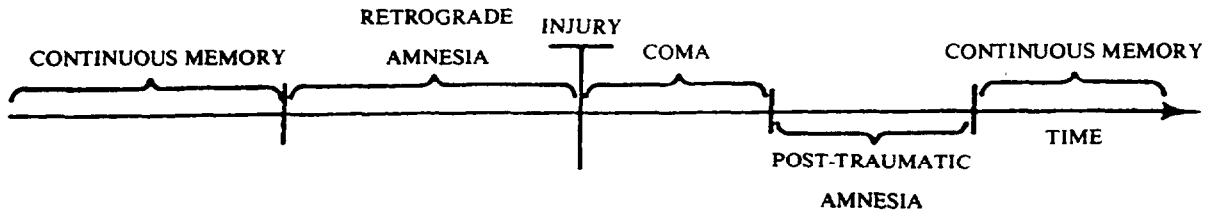

Date and time of first retrograde event reported by patient _____

Duration of retrograde amnesia as calculated from dates of accident and first retrograde memory _____

Date and time of first post traumatic memory _____ . Duration of post-traumatic amnesia as computed from date of accident and date of first anterograde event recalled _____

U.S. Naval Flight Surgeon's Manual

3. Motor
 - Muscle Status Tenderness, atrophy, fasciculations
 - Strength Drift
 - Tone mirroring
 - Character
 - Tremor
 - Gegenhalten

4. Sensory
 - LT
 - PP
 - Vibration
 - Proprioception
 - Temperature
 - Stereognosis
 - Graphesthesia
 - Double Simultaneous Stimulation

5. Cerebellum
 - FTN
 - HTS
 - RAM
 - Rebound

6. Gait
 - Regular
 - Stress
 - Tandem
 - Station
 - Standard Romberg Eyes Open/Eyes Closed
 - Tandem Romberg Eyes Open/Eyes Closed
 - Sharpened Romberg Eyes Open/Eyes Closed

7. Cutaneous Reflexes
 - Glabellar
 - Snout
 - Root
 - Palmomental
 - Jaw

Neurology

Abdominal
Cremasteric

8. Muscle Stretch Reflexes	R	L	REFLEXES
Pectorals.	—	—	+ more than other side
Deltoids	—	—	- less than other side
Biceps	—	—	0 Absent
Brachioradialis	—	—	1 Present with reinforcement
Triceps	—	—	2 Present
Patellar	—	—	3 Brisk/Transient Clonus
Prepatellar	—	—	4 Increased/sustained clonus
Adductor	—	—	
Crossed Adductor	—	—	
Biceps femoris (hamstring)	—	—	
Gastrocnemius (Achilles)	—	—	NL = Normal
Hoffman	—	—	NT = Not Tested
Tromner	—	—	
Finger Flexion	—	—	
Wartenberg	—	—	

9. Plantar Responses	R	L	
Babinski	—	—	+ = extensor (abnormal)
Chaddock..	—	—	- = flexor (normal)

Neurology Division Head

Date

Patients Identification:

Name:

SSN:

RANK:

DUTY STATION:

APPENDIX 7-D

APPROACH TO NEW ONSET SEIZURES

1. Quickly assess ABC's, protect C-Spine if suspicion of trauma.
2. Establish that the diagnosis of seizures is correct, statements of witnesses and EMT's are essential. Pertinent history should include head trauma, alcohol or drug use, prior seizures.
3. Physical examination including general exam for systemic derangement, infection, organ failure. Specific neurological evaluation should assess postictal confusion, focal neurological deficit.
4. Assess for continued seizure activity, or failure of patient to regain consciousness (see Appendix 7-B. Status Epilepticus).
5. Airway management: Oxygen by nasal cannula or face mask, nasal or oropharyngeal airway, blood pressure, cardiac, and respiratory monitor.
6. Establish secure IV with 18 or 20 gauge needle, normal saline KVO (Dilantin precipitates in glucose solutions).
7. Laboratory Tests:
 - a. STAT CBC, electrolytes including calcium and magnesium, EKG, UA, blood sugar.
 - b. CXR (R/O aspiration), cross table lateral C-spine if history of trauma.
 - c. Medication screen: Aminophylline, Digoxin, Lithium, anticonvulsants.
 - d. Drug screen: ETOH, amphetamines, cocaine, barbituates, PCP.
 - e. Blood cultures, serum and urine Counter Immune Electrophoresis (CIE) antigens, if septic.
8. Cranial CT Scan: Noncontrast: R/O subarachnoid hemorrhage, contrast: R/O tumor/abscess

Neurology

9. Lumbar puncture: If meningeal signs and no focal neurological deficits. (Start IV antibiotics if meningitis is suspected)
10. Anticonvulsant therapy: Oral loading usually effective if not in Status Epilepticus, single idiopathic seizure may not require therapy
11. Frequent reassessment of patient's clinical status.

APPENDIX 7-E

APPROACH TO STATUS EPILEPTICUS

1. Quick assessment of general and neurological state, verify that unconsciousness persists.
2. Maintain airway (chin lift/jaw thrust).
3. Prevent aspiration by placing in semiprone (Fowler) position, clear secretions, insert airway or intubate, administer oxygen, insert NG tube.
4. Start two secured IV lines, 18-20 gauge, normal saline KVO.
5. Monitor vital signs frequently, cardiac/respiratory monitor.
6. Laboratory tests, CT scan, and lumbar puncture (see Appendix 7-D, Approach to Seizures).

7. TREATMENT OF STATUS EPILEPTICUS

- a. Thiamine 100 mg IM.
- b. D50W - 1 AMP (50 ml) IV push.
- c. Narcan 1 amp IV/ ET tube.
- d. Valium 5-10 mg IV/ ET tube - Note: Only temporizing measure to control seizure to assist IV or ET tube insertion. Caution: Respiratory depressant, particularly with barbituates.
- e. DILANTIN (PHENYTOIN)
Load: 15-20 MG/KG at 50 mg/min slow IV push on ECG monitor 4 Ampules of 250 mg/5 ml in 80 ml normal saline titrated over 20 minutes (set IMED at 300 ml/hour), observing closely for arrhythmia or hypotension.
Maintenance dose: 100 mg slow IV push q8h to maintain therapeutic levels.
- f. If status epilepticus persists over 30 minutes: Phenobarital 15-20 MG/KG up to 100 mg/min, following closely for respiratory depression, hypotension, consider intubation.

Neurology

- g. By 45 minutes consider Paraldehyde 4% (5 ml in 5 ml mineral oil IM in buttocks (10 ml per side) or rectally, repeated every 30 minutes as necessary. Note: Very messy drug, smells funny, may melt plastic, and often not routinely available.
- h. Lidocaine 1MG/KG IV/ or via ET Tube as loading dose then 2-4 ug/minute IV, closely monitoring cardiac status.
- i. By 45-60 minutes if still in status, try general anesthesia.
- j. Electroencephalogram (EEG) as indicated.

APPENDIX 7-F

**Naval Aerospace Medical Institute
Neurology Division, Code 24
Syncope Test Battery**

Requesting Physician:

Clinical History:

	HR	BP	Symptoms Reproduce	
			YES	NO
ORTHOSTATIC TESTING				
Horizontal (Supine)	_____	_____	()	()
Vertical (Standing)	_____	_____	()	()
Horizontal x 15 min then vertical	_____	_____	()	()
Inverted head down	_____	_____	()	()
Squatting to standing	_____	_____	()	()
UNILATERAL CAROTID MASSAGE (15 SEC)				
Left	_____	_____	()	()
Right	_____	_____	()	()
BILATERAL OCULAR PRESSURE (15 SEC)	_____	_____	()	()
BREATH HOLDING AT MAX INSPIRATION				
(60 SEC)	_____	_____	()	()
VALSALVA MANEUVER (30 SEC)	_____	_____	()	()
HYPERVERTILATION (1-3 MIN)	_____	_____	()	()
HYPERVERTILATION (1 MIN) THEN				
BREATH HOLDING (15-SEC)	_____	_____	()	()

Neurology

COLD PRESSOR TEST (HAND IN O C FOR 1 MIN-) . _____ _____ () ()

POSITIVE PRESSURE BREATHING (1-3 MIN) _____ _____ () ()

Neurology Division Head

Date

Patients Identification:

Name:

SSN:

RANK:

DUTY STATION:

APPENDIX 7-G

**Naval Aerospace Medical Institute
Neurology Division, Code 24
Vestibular Function Testing**

Requesting Physician:

Clinical History:

POSITIONAL TESTING

Hallpike Maneuver
Head Hanging
Head Shaking
Barany Chair Rotation

FISTULA TESTING

Tragus Compression
Suction - Hennebert's Sign
Noise - Tullio's Phenomenon
Valsalva
Swallowing

POSTURAL TESTING

Sharpened Romberg
Quix Test
Past Pointing

GAIT TESTING

Fukada Step Test
Unterberger Step Test

LABYRINTHINE TESTING

Calories

VISUAL TESTING

Pursuit
Saccades

Neurology

OKN
VOR
VOR Suppression

NYSTAGMUS EVALUATION

Type
Direction
Congugate
Latency
Fatigue/Habituation
Fixation Effects
Positional Changes
Gaze Evoked

Signature & Title

Date

Patients Identification:

Name:

SSN:

Rank:

Duty Station:

APPENDIX 7-H

**Naval Aerospace Medical Institute
Neurology Division, Code 24
Spine and Nerve Evaluation**

NECK AND UPPER EXTREMITY EXAMINATION

NECK RANGE OF MOTION _____ FLEXION _____ EXTENSION
 _____ ROTATION _____ LATERAL FLEXION
 PARASPINAL MUSCLE SPASM _____ LEFT _____ RIGHT

PAIN OR OTHER SYMPTOMS	RIGHT	LEFT
AXIAL COMPRESSION	_____	_____
SPURLINGS' SIGN	_____	_____
ADSON'S MANEUVER	_____	_____
COSTOCLAVICULAR MANEUVER	_____	_____
TINEL'S SIGN		
SPIRAL GROOVE	_____	_____
LIGAMENT OF STRUTHER'S	_____	_____
OLECRANON GROOVE	_____	_____
CUBITAL TUNNEL	_____	_____
CARPEL TUNNEL	_____	_____
PHALEN'S SIGN	_____	_____
FROMENT'S SIGN	_____	_____

SENSATION (- = DECREASED, NL = NORMAL, + = INCREASED)

		RIGHT	LEFT
C - 5 DERMATOME	PIN PRICK (PP)	_____	_____
C - 5 DERMATOME	LIGHT TOUCH (LT)	_____	_____
C - 6 DERMATOME	PIN PRICK (PP)	_____	_____
C - 6 DERMATOME	LIGHT TOUCH (LT)	_____	_____
C - 7 DERMATOME	PIN PRICK (PP)	_____	_____
C - 7 DERMATOME	LIGHT TOUCH (LT)	_____	_____
C - 8 DERMATOME	PIN PRICK (PP)	_____	_____
C - 8 DERMATOME	LIGHT TOUCH (LT)	_____	_____
T - 1 DERMATOME	PIN PRICK (PP)	_____	_____
T - 1 DERMATOME	LIGHT TOUCH (LT)	_____	_____

Neurology

MUSCLE STRETCH REFLEXES

	RIGHT	LEFT	
PECTORAL	_____	_____	
DELTOID	_____	_____	
BICEPS	_____	_____	
BRACHIORADIALIS	_____	_____	
TRICEPS	_____	_____	
HOFFMAN'S SIGN	_____	_____	
TROMNER'S SIGN	_____	_____	
FINGER FLEXION	_____	_____	
PREPATELLAR	_____	_____	0 = ABSENT
PATELLAR	_____	_____	1 = PRESENT WITH REINFORCEMENT
KNEE ADDUCTOR	_____	_____	2 = NORMAL
CROSSED ADDUCTOR	_____	_____	3 = TRANSIENT CLONUS
ANKLE (ACHILLES)	_____	_____	4 = SUSTAINED CLONUS

NECK AND UPPER EXTREMITY EXAMINATION
(CONTINUED)

	RIGHT	LEFT	
PLANTER SIGNS			
BABINSKI	_____	_____	+ = EXTENSOR (ABNORMAL)
CHADDOCK	_____	_____	- = FLEXOR (NORMAL)

MOTOR FUNCTION

- 5 = NORMAL
- 4+ = SLIGHTLY LESS THAN NORMAL
- 4 = MODEST WEAKNESS
- 4- = MODERATE WEAKNESS (BETTER THAN JUST ANTI-GRAVITY)
- 3 = OVERCOMES GRAVITY (ANTI-GRAVITY)
- 2 = MOVES WITH GRAVITY REMOVED (PARALLEL TO GROUND)
- 1 = FLICKER OF MOVEMENT ONLY
- 0 = NO MOVEMENT

U.S. Naval Flight Surgeon's Manual

	RIGHT					LEFT								
SHOULDER ELEVATORS	5	4+	4	4-	3	2	1	5	4+	4	4-	3	2	1
SHOULDER DEPRESSORS	5	4+	4	4-	3	2	1	5	4+	4	4-	3	2	1
SHOULDER ABDUCTORS	5	4+	4	4-	3	2	1	5	4+	4	4-	3	2	1
SHOULDER ADDUCTORS	5	4+	4	4-	3	2	1	5	4+	4	4-	3	2	1
EXTERNAL ROTATORS	5	4+	4	4-	3	2	1	5	4+	4	4-	3	2	1
INTERNAL ROTATORS	5	4+	4	4-	3	2	1	5	4+	4	4-	3	2	1
ELBOW FLEXOR (SUPINATED)	5	4+	4	4-	3	2	1	5	4+	4	4-	3	2	1
ELBOW FLEXOR (PRONATED)	5	4+	4	4-	3	2	1	5	4+	4	4-	3	2	1
ELBOW EXTENSORS	5	4+	4	4-	3	2	1	5	4+	4	4-	3	2	1
FOREARM PRONATORS	5	4+	4	4-	3	2	1	5	4+	4	4-	3	2	1
FOREARM SUPINATORS	5	4+	4	4-	3	2	1	5	4+	4	4-	3	2	1
WRIST EXTENSORS	5	4+	4	4-	3	2	1	5	4+	4	4-	3	2	1
WRIST FLEXORS (ULNAR)	5	4+	4	4-	3	2	1	5	4+	4	4-	3	2	1
WRIST FLEXORS (RADIAL)	5	4+	4	4-	3	2	1	5	4+	4	4-	3	2	1
FINGER FLEXORS (DISTAL)	5	4+	4	4-	3	2	1	5	4+	4	4-	3	2	1
FINGER FLEXORS (PROXIMAL)	5	4+	4	4-	3	2	1	5	4+	4	4-	3	2	1
FINGER EXTENSORS	5	4+	4	4-	3	2	1	5	4+	4	4-	3	2	1
THUMB FLEXOR	5	4+	4	4-	3	2	1	5	4+	4	4-	3	2	1
THUMB ABDUCTOR	5	4+	4	4-	3	2	1	5	4+	4	4-	3	2	1
THUMB OPPOSER	5	4+	4	4-	3	2	1	5	4+	4	4-	3	2	1
FINGER INTRINSICS	5	4+	4	4-	3	2	1	5	4+	4	4-	3	2	1

Neurology Division Signature

Date

Patients Identification:

Name:

SSN:

RANK:

DUTY STATION:

Neurology

Naval Aerospace Medical Institute
Neurology Division, Code 24
Spine and Nerve Evaluation

BACK AND LOWER EXTREMITY EXAMINATION

LOW BACK _____ RANGE OF MOTION _____ FLEXION _____ EXTENSION
_____ ROTATION _____ LATERAL FLEXION
PARASPINAL MUSCLE SPASM _____ LEFT _____ RIGHT

	RIGHT	LEFT	BACK PAIN	LEG PAIN
STRAIGHT LEG RAISING	_____	_____	_____	_____
LESEQUE'S MANEUVER	_____	_____	_____	_____
FEMORAL STRETCH MANEUVER	_____	_____	_____	_____
PATRICK'S SIGN - FABERE	_____	_____	_____	_____
EARLY /NAFZINGER'S SIGN	_____	_____	_____	_____

	RIGHT		LEFT	
CAN PATIENT BEND AND TOUCH THIGH?	YES___	NO___	YES___	NO___
CAN PATIENT BEND AND TOUCH KNEES?	YES___	NO___	YES___	NO___
CAN PATIENT BEND AND TOUCH CALVES?	YES___	NO___	YES___	NO___
CAN PATIENT BEND AND TOUCH ANKLES?	YES___	NO___	YES___	NO___
CAN PATIENT BEND AND TOUCH TOES?	YES___	NO___	YES___	NO___
CAN PATIENT TOE WALK?	YES___	NO___	YES___	NO___
CAN PATIENT HOP ON ONE LEG?	YES___	NO___	YES___	NO___

U.S. Naval Flight Surgeon's Manual

BACK AND LOWER EXTREMITY EXAMINATION
(CONTINUED)

CAN PATIENT HEEL WALK? YES___ NO___ YES___ NO___
 CAN PATIENT DO DEEP KNEE BEND? YES___ NO___ YES___ NO___
 IS THERE CALF ATROPHY? YES___ NO___ YES___ NO___
 IS THERE TIBIALIS ANTERIOR ATROPHY? YES___ NO___ YES___ NO___
 EXTENSOR DIGITORUM BREVIS ATROPHY? YES___ NO___ YES___ NO___

Patients Identification:

Name:

SSN:

RANK:

DUTY STATION:

SENSATION (- = DECREASED, NL = NORMAL, + = INCREASED)

		RIGHT	LEFT
L - 4 DERMATOME	PIN PRICK (PP)	_____	_____
L - 4 DERMATOME	LIGHT TOUCH (LT)	_____	_____
L - 5 DERMATOME	PIN PRICK (PP)	_____	_____
L - 5 DERMATOME	LIGHT TOUCH (LT)	_____	_____
S - 1 DERMATOME	PIN PRICK (PP)	_____	_____
S - 1 DERMATOME	LIGHT TOUCH (LT)	_____	_____

MOTOR FUNCTION

5 = NORMAL

4+ = SLIGHTLY LESS THAN NORMAL

4 = MODEST WEAKNESS

4- = MODERATE WEAKNESS (BETTER THAN JUST ANTI-GRAVITY)

3 = OVERCOMES GRAVITY (ANTI-GRAVITY)

2 = MOVES WITH GRAVITY REMOVED (PARALLEL TO GROUND)

1 = FLICKER OF MOVEMENT ONLY

0 = NO MOVEMENT

Neurology

	RIGHT					LEFT								
HIP FLEXORS	5	4+	4	4-	3	2	1	5	4+	4	4-	3	2	1
HIP EXTENSORS	5	4+	4	4-	3	2	1	5	4+	4	4-	3	2	1
HIP ADDUCTORS	5	4+	4	4-	3	2	1	5	4+	4	4-	3	2	1
HIP ABDUCTORS	5	4+	4	4-	3	2	1	5	4+	4	4-	3	2	1
KNEE FLEXORS	5	4+	4	4-	3	2	1	5	4+	4	4-	3	2	1
KNEE EXTENSORS	5	4+	4	4-	3	2	1	5	4+	4	4-	3	2	1
ANKLE DORSIFLEXORS	5	4+	4	4-	3	2	1	5	4+	4	4-	3	2	1
ANKLE PLANTAR FLEXORS	5	4+	4	4-	3	2	1	5	4+	4	4-	3	2	1
ANKLE INVERTORS	5	4+	4	4-	3	2	1	5	4+	4	4-	3	2	1
ANKLE EVERTORS	5	4+	4	4-	3	2	1	5	4+	4	4-	3	2	1
GREAT TOE EXTENSOR	5	4+	4	4-	3	2	1	5	4+	4	4-	3	2	1
TOE EXTENSORS	5	4+	4	4-	3	2	1	5	4+	4	4-	3	2	1
TOE FLEXORS	5	4+	4	4-	3	2	1	5	4+	4	4-	3	2	1
TOE INTRINSICS (SPREAD)	5	4+	4	4-	3	2	1	5	4+	4	4-	3	2	1

MUSCLE STRETCH REFLEXES

PREPATELLAR	_____	_____	0 = ABSENT
PATELLAR	_____	_____	1 = PRESENT WITH REINFORCEMENT
KNEE ADDUCTOR	_____	_____	2 = NORMAL
CROSSED ADDUCTOR	_____	_____	3 = TRANSIENT CLONUS
ANKLE (ACHILLES)	_____	_____	4 = SUSTAINED CLONUS

Neurology Division Signature:

Date

Patients Identification:

Name:

SSN:

RANK:

DUTY STATION:

CHAPTER 8

OTORHINOLARYNGOLOGY

Introduction

Section I. Clinical ENT

Otology

Rhinology

Examination of the Mouth and Pharynx

Laryngology

Section II. Audiology

The Physics of Sound

Measurement of Hearing

Interpretation of Hearing Tests

Section III. The Navy Hearing Conservation Program (HCP)

Introduction

Implementation of HCP

Noise Measurement and Exposure Analysis

Audiometry in the HCP

Hearing Protectors

References and Bibliography

Appendix 8-A. Model Instruction for Establishing Noise Control and Hearing Conservation Program

INTRODUCTION

Otorhinolaryngology (Ear, Nose and Throat, or ENT) faces the same problems in military aviation medicine that are found in civilian medical practice, but the problems are compounded by (1) the exceptional environmental conditions of aviation, and (2) the fact that some of the symptoms experienced may degrade flight performance to the point that the safety of the aviator and his passengers may be threatened. The exceptional environmental conditions include rapid pressure changes, high ambient noise levels, and unusual linear and angular accelerations. These environmental conditions can elicit episodes of pain, vertigo, disequilibrium, and nausea. They may also introduce communication problems through temporary or permanent impairment of auditory function. In addition, these effects may be of sudden onset in apparently normal individuals.

U.S. Naval Flight Surgeon's Manual

This chapter describes clinical ENT issues, audiology, and the Navy Hearing Conservation Program (HCP). Flight surgeons may find themselves at long distances from medical facilities when ENT problems arise, or they may have to care for patients until they can get an appointment at the nearest facility; therefore, this chapter is intended to assist the physician with common clinical problems.

Due to the constant problem with acoustic trauma in aviation and aboard Navy ships, the evaluation and conservation of hearing is an important part of the flight surgeon's responsibility. He is responsible, in part, for administering the Navy Hearing Conservation Program.

The material in this chapter is closely allied with that presented in Chapter 3, *Vestibular Function*, which discusses illusions and disorientation effects which can result as the vestibular system reacts to the unique stresses of aviation.

SECTION I:

CLINICAL ENT

Otology

The Management of External Ear Problems

Hematomas. Trauma to the auricle may cause hemorrhage beneath the perichondrium, most often on the superior lateral surface, resulting in a hematoma. Left untreated, the slow absorption of blood, loss of nourishment to the cartilage, and infection may lead to a deformed auricle or "cauliflower" ear.

Management may take two forms. In the early stages, aspiration of the blood using sterile technique with a large 14-gauge needle is recommended by many physicians. A pressure dressing is then applied. For large, chronic, or recurrent hematomas, incision and drainage are recommended. The entire ear is prepared with Betadine, and under local Xylocaine anesthesia, a large curving incision is made through the skin of the scaphoid fossa following the curvature of the helix. The hematoma is then evacuated using sterile technique. In some chronic or recurrent cases, instead of blood there is only xanthochromic fluid. Some surgeons advise curettage of the cyst walls. A thin rubber drain is inserted the length of the hematoma sac and then withdrawn over the next two or three days. Fine nylon or silk interrupted sutures about one centimeter apart are used for closure of the incision, and a pressure dressing is applied. Through and through monofilament sutures tied over soft sponges for direct pressure are also effective.

Otorhinolaryngology

The flight surgeon is cautioned that aspiration of aural hematomas without meticulous attention to sterile technique is an invitation to disaster because of the excellent culture medium contained therein.

Perichondritis and Chondritis of the Auricle. The spread of infection, most often after trauma, to the perichondrium results in a painful, hot cellulitis of the pinna with brawny edema. Aggressive systemic antibiotic therapy and warm, wet compresses are the treatment of choice, along with repeated cleaning of the wound. If chondritis develops, the infected area must be opened and drained with excision of infected cartilage. For these infections, cultures should be made for proper drug therapy.

Lacerations. The basic principles of handling a laceration of the auricle are to avoid excessive debridement, approximate the cartilage with perichondrial sutures on both sides, use white silk or cotton for buried sutures on the thin lateral surface, and use good splinting with a pressure dressing. Even though a portion of the ear may look nonviable, it is usually best to clean, approximate, splint, and then wait for demarkation before final debridement. Through and through sutures tied lightly over cotton rolls, etc., may be used for splinting as well as the pressure dressing. Exposed cartilage or subcutaneous tissue should be covered with fine mesh gauze impregnated with an antibiotic ointment. Adequate antibiotic coverage is strongly recommended.

Ear Dressing Procedure. The purpose of the dressing is to splint, protect, and absorb drainage from the ear with maximum comfort to the patient. It must also resist movement or displacement.

The bandage material most commonly used is a supportive pad behind the ear, a fluff dressing of loose gauze or mechanic's waste, and a support covering of the dressing with material like Kling^(R) or Kerlix^(R) elastic or stretch gauze.

First, two or three 4 x 4-inch pads are folded together in half, and then a "C" shape is cut out of the center that will fit behind and around the ear. Next, the entire ear is covered with two or three inches of fluff dressing or mechanic's waste. If splinting of the pinna contours is important, as in lacerations, this can be accomplished by careful insertion of ointment-impregnated cotton in the grooves of the scaphoid fossa, canal meatus, and concha.

The external bandage of an elastic or stretch gauze usually begins on the forehead and is always wrapped from the front to the back of the ear. To keep the dressing out of the patient's eyes, two pieces of umbilical tape or thin gauze are laid vertically on both sides of the forehead. The stretch gauze is wrapped first across the center of the fluff, across the lower occiput, above the opposite

ear, and then repeated below and above the first wrap, resulting in a football helmet-like appearance. The forehead tapes are now tied and tape strips applied to hold the gauze in position, using intermittent applications about six inches in length.

Foreign Bodies in the External Canal. Anything that will fit has been found in the external auditory canal. Some of the foreign bodies are inert and cause no problems or symptoms, but most commonly they produce a canal blockage with a mild decrease in hearing, itching, infection, and drainage or even a cough, mediated through pressure on the twig of the tenth cranial nerve (Arnold's nerve).

Removal of round objects is most difficult, and it is best accomplished with a fine, blunt, right angle hook that can be inserted past and behind the object. Special cup or serrate jaw forceps can also be used. Hard, sharp, and large objects should be softened, if possible, and removed with care, protecting the canal from trauma and bleeding. Compressed strips of Gelfoam may be tried on sharp corners. Friable or adherent material may require loosening or dissolution before removal. Debrox (carbamide peroxide) works well in most cases. A fine stream of water, two percent acetic acid in water, or alcohol is used for irrigation and directed under direct vision and controlled pressure. Hydrosopic objects such as corn or peas may swell if saturated with water, therefore, alcohol irrigation or forcep/hook removal is recommended. Live insects should be killed rapidly by flooding of the canal with Lidocaine, alcohol, or oil and then removed with forceps. After the object has been removed, the canal should be suction-cleaned or wiped dry and eardrops or ointments applied for treatment of any possible tissue trauma or infection.

External Otitis. The lining of the external auditory canal, including the outer surface of the tympanic membrane, is facial skin and, therefore, susceptible to the same infections as the face. The outer third, surrounded by an incomplete ring of cartilage, contains hairs and sebaceous and ceruminous glands. Infection may take place in any of these structures, most commonly as a furuncle. The fissures of Santorini in the floor of the external meatus cartilage may allow for spread of infection into the soft tissues of the periauricular region.

Treatment of furuncles consists of application of dry heat to the external ear and direct application of topical antibiotic solution or ointment to the inflamed area. If the furuncle points, the top should be removed by suction or needle to allow for drainage. Diffuse swelling or cellulitis require systemic antibiotics. Recurrent furuncles may be controlled by applications of Cresatin^(R), Betadine, or antibiotic ointment to the meatus region daily.

The most common causes of infections in the external auditory canal are maceration of the skin from water or other fluid drainage and trauma, often self-inflicted, when trying to scratch or

Otorhinolaryngology

clean wax from the canal. The canal becomes inflamed and may begin to weep, and there may be mild pain on movement of the pinna. Predominant causative organisms are *Srphlococcus aureus* and *Pseudomonas*. Progress of the inflammation leads to variable degrees of canal swelling, fever, severe pain, and occasionally trismus.

Meticulous cleaning of the entire canal is the single, most important form of treatment. The canal should be gently suctioned and cleared of visible debris, and the inflamed tissue should be wiped with antibiotic drops or two percent acetic acid solution. Carbamide peroxide (Debrox) may be needed if there is hard or thick debris. Blind suction and wiping of diffusely swollen canals should be very gentle with attention to the direction of the canal and distance to the tympanic membrane (2.5 cm). A wet cotton canal wick about three-quarters to one inch long or the commercial wicks (i.e., Pope Oto-wick TM) are recommended for use in all cases with diffuse swelling of the canal. Burrow's solution (1: 10) is an excellent astringent-type medication, but any of the antibiotic-cortisone aqueous otic preparations can be used on the wick. The cotton wick should be large enough to be snug and in contact with the inflamed tissues. It is kept wet and removed after 24 hours. Antibiotic drops themselves create debris, so the canal should be cleaned and a new wick inserted daily until the swelling has markedly resolved. A patient should never be given a bottle of drops and sent off on a course of self-treatment. Patients with adenopathy and cellulitis should be treated with systemic antibiotics, and the pain can be controlled with a strong anodyne.

Otomycosis of the external canal constitutes less than five percent of all cases of external otitis, but it is commonly associated with long-term use of antibiotic drops and wet debris in the canal. The most common causative agents are *Aspergillus* species and *Monilia*. When the canal is *not inflamed* and the infection is mostly a saprophytic fungal growth, the cerumen, debris, and fungal growth are suctioned out followed by flushing of the canal with alcohol and thorough drying. When the canal is inflamed, gentle, meticulous suction is the first step in treatment. Mycostatin or Fungizone cream is applied for *Candida* infections. *Aspergillus* species may require treatment with two percent gentian violet in 55 percent alcohol, or one percent thymol solution in ethyl alcohol, or perhaps best of all, a 25 percent m-cresyl acetate (Cresatin) solution. In chronic otorhea, the underlying pathology must be controlled, or the fungus will return.

The Middle Ear

Anatomy. The part of the ear which is perhaps of greatest importance in aviation is the Eustachian tube. It is approximately 37 mm long and connects the middle ear with the nasopharynx. The lateral or tympanic third of the tube is bony, the medial or pharyngeal portion is cartilaginous. The course of the tube is forward, downward, and inward from the ear, opening

into the nasopharynx about 15 mm lower than the tympanic opening in adults. It lies just posterior to the inferior nasal turbinate. The cartilaginous and bony portions meet at an obtuse angle in the narrowest portion of the tube. The osseous tympanic orifice is open, but the cartilaginous tube is a closed, slit-like cavity. It must be opened by acts of swallowing or yawning that contract the tensor and levator veli palatini muscles or by direct air pressure.

Eustachian Tube Dysfunction. Edema or tissue hypertrophy in or about the Eustachian tube from infections, inflammations, or allergy is the most common cause of acute dysfunction. Chronic dysfunction is usually associated with anatomic abnormalities, such as scarring and chronic disease processes. With an acute, unexplained, unilateral dysfunction, especially in the older age group, one should always look diligently for tumor in the nasopharynx.

Symptoms of Eustachian tube dysfunction are generally a fullness in the ear, mild intermittent discomfort or pain, and a mild decrease in hearing. The tympanic membrane shows some retraction with either a normal appearance or slight hyperemia of the vascular strip. The short process of the malleus is prominent or foreshortened, and the malleus may angle more posteriorly than usual. In chronic cases, there is a "dimple" or retraction of the pars flaccida. Tympanometry may indicate a chronic negative pressure.

In the acute disease, treatment is directed toward control of any infection in the nasopharynx, and a decongestant with an antihistamine is recommended. Stubborn conditions, with no obvious etiology and no previous history, often respond to two weeks of nasal steroid insufflation and occasional politizerization. Cases that develop after an initial ear block or ear infection and resist other conservative treatment, occasionally respond to ventilation tube insertion for a minimum of three months. This can also be effective in some longstanding chronic cases. In children and selected resistant cases in adults, an adenoidectomy may be advisable, if hypertrophic or suspected of chronic infection. A silent or undiagnosed sinusitis can be associated with eustachian tube dysfunction.

Direct Trauma. Direct trauma can occur from the increase in air or fluid pressure in the ear canal caused by a slap to the side of the head, falling off water skis, improper water entry during a dive, ear blocks while flying, ear squeeze during SCUBA, or improper irrigation of the ear canal. This may result in rupture of the tympanic membrane, laceration of the canal, and occasionally, ossicular disarticulation or subluxation of the stapes. There may be some bleeding, often marked tinnitus, and occasional vertigo and hearing loss, depending of the degree and location of the injury. Infection could result when foreign material, especially water, is forced into the middle ear through a ruptured tympanic membrane. Treatment should consist of suction clearing, oral antibiotic coverage for five to seven days, and a base line audiogram. Clean, small traumatic per-

Otorhinolaryngology

forations usually heal within three weeks, but the patient must avoid any significant barometric pressure changes as the perforation nears closure, and at no time should water or other fluids be allowed in the ear. *Keep The Ear Dry!* Never use ear drops, unless a true infection with purulent drainage develops and then use only the suspension preparations.

Chronic Perforations of the Tympanic Membrane. Small, dry, central perforations may be closed by cauterizing the edge of the perforation with trichloroacetic acid. It can be left open or one may elect to place a small patch made from cigarette paper or other thin paper over the perforation. Usually the patch is moistened in antibiotic drops before application.

Large perforations with a dry middle ear may be closed by a tissue graft if the Eustachian tube is functioning. Testing of this function is fairly accurate by tympanography. Poor or absent Eustachian tube function gives surgery a decreased chance of success. If the ossicles show fixation or if there is considerable scarring with adhesions, hearing might decrease somewhat further even though the perforation is closed, as a result of the poorer transmission of sound and the cancellation effect of sound striking both windows at the same time. A perforation, per se, which allows for equalization of pressure between the middle ear and the atmosphere does not affect flying. Sudden cold or hot air or water and loud noise may cause vertigo more easily in the perforated ear. Of course, water in a perforated ear usually leads to infection and drainage.

Barotrauma. Aerotitis media occurs rather frequently in the aviation community and is directly related to the function of the Eustachian tube in equalizing the pressure between the atmosphere and the middle ear space. The tympanic end of the Eustachian tube is bony and usually open, whereas the pharyngeal end is cartilaginous, slit-like, and closed, acting like a one-way flutter valve. Opening of the Eustachian tube occurs with the contraction of the levator and tensor veli palatini muscles during acts of chewing, swallowing, or yawning. As one ascends to altitude, the outside pressure decreases, and the greater middle ear pressure forces open the "flutter valve", pharyngeal end of the Eustachian tube every 400 to 500 feet to about 35,000 feet, and then every 100 feet thereafter. During descent, the collapsed, closed, pharyngeal end of the Eustachian tube prevents air from entering the tube. The increasing relative negative pressure in the middle ear further holds the soft tissues together, and muscular (active) opening of the Eustachian tube must be accomplished before the differential pressure reaches 80 or 90 mm Hg. Once this magnitude of differential pressure is established, muscular action cannot overcome the suction effect on the closed Eustachian tube, and the tube is said to be "locked". This relative negative pressure not only retracts the tympanic membrane but pulls on the delicate mucosal lining, leading to effusion and hemorrhage. Pain may be severe, with nausea and occasionally vertigo. On rare occasions rupture of the tympanic membrane has been seen, and some aircrew-men have developed shock or syncope.

Otoscopic presentations vary greatly, but they can range from a retraction of the tympanic membrane with the classic backward displacement of the malleus, a prominent short process, and anterior and posterior folds, to hyperemia or hemorrhages in the tympanic membrane. There may also be varying amounts of serous and bloody fluid visible behind the membrane.

Active treatment is directed toward equalization of pressure, relief of pain, and prevention or treatment of infections in the ear, Eustachian tube, or nasopharynx. In an aircraft or low-pressure chamber, descent should be stopped, and, if possible, there should be a return to a higher altitude where equalization can be attempted using the Valsalva maneuver or Politzer method. Descent should then be gradual, if possible. Middle ear inflation (poltizerization) should be done especially if a negative pressure appears to remain on the ground and there is pain present. Caution should be exercised if there is an upper respiratory infection present. Oral decongestants may be helpful and are recommended, but the effect of antihistamines is questionable. In cases of thick effusion and poor Eustachian tube function or inability *to* Valsalva, daily or every other day politzerization or tubal insufflation may be in order. Persistent serous fluid may be removed by needle aspiration, but thick mucoid or organized blood must be removed by myringotomy if it has not cleared after two or three weeks of intensive therapy. Antibiotics are used only when infection is present in the upper respiratory region or develops during treatment.

Delayed "Ear Block"

1. *The Valsalva Maneuver.* The procedure for self or mechanical inflation of the middle ear space is termed the Valsalva maneuver. It has been frequently observed in young student pilots and aircrewmembers receiving earblocks in the low-pressure chamber or in flight during rapid descent, that they were unable to perform a proper Valsalva, frequently because they did not know the correct technique or were trying too hard. Several physiological conditions make the Valsalva maneuver more difficult. They are flexing the head or the chest, twisting the head to one side, pressure on the jugular vein, and being in the-prone position.

The Valsalva maneuver requires the nose and mouth to be closed and the vocal cords open. Air pressure is then forced into the nose and nasopharynx forcing open the Eustachian tube and increasing the pressure in the middle ear space. This can be observed as a bulging of the tympanic membrane, especially in the posterior superior quadrant.

The most frequently observed problems with the students were the fear that they would damage or rupture their eardrums, closing the vocal cords when they build up pressure like in the M-I maneuver, and straining so hard that marked venous congestion in the head further prevents opening of the Eustachian tube.

Otorhinolaryngology

Although it is possible to rupture the tympanic membrane when it is abnormally weak from previous disease, simple inflation done properly has little danger. Repeated overinflation does carry some risk and is discussed under politzerization and round window rupture.

One of the best methods to prevent vocal cord closure is to instruct the patient or aircrewman to close his nose with his fingers and then attempt to blow his fingers off his nose, causing the nose to bulge from the pressure. The buildup of pressure should be rapid and sustained no longer than one to one and a half seconds to prevent the venous congestion that reduces the efficiency of the Eustachian tube function.

Should the flight surgeon fail to see any movement of the tympanic membrane when he is evaluating the patient for Valsalva, he should then look for the small, quick retraction movement of the Toynbee maneuver, accomplished by closing the nose and swallowing. If a Toynbee is present and the aircrewman feels pressure in his ears during Valsalva, has no sign of ear disease, and no history of problems with pressure changes, he usually can be qualified for aviation. The best evaluation for candidates is, of course, the low-pressure chamber or an actual unpressurized flight with rapid descent. Difficulty with pressure equalization during SCUBA diving is often a poor prognosis for aviation.

2. *Politzerization.* Politzerization is the mechanical inflation of the middle ear usually required for treatment of acute ear and sinus blocks, chronic Eustachian tube dysfunction, or middle ear disease. To perform this procedure, one needs a source of pressure, either an air pump or rubber bag, with a one-way valve. For the air pump, it is most important to have variable control of the pressure and a pressure gauge, if possible. Most pressure/vacuum units in the Navy have a pressure gauge calibrated in pounds per square inch. If no gauge is present, the starting pressure should just be sufficient to blow off a lightly applied finger. When a pressure gauge is available, initial attempts should be done with ten pounds per square inch or less. To seal and deliver the pressure into the nose, an olive tip of metal, hard rubber, or glass is the most efficient. This tip may be attached to an atomizer if smoke or mist is desired for diagnostic or therapeutic reasons. If the patient has a very thin tympanic membrane, lower pressure must be tried first. An explanation to the patient is important to assure cooperation and prevent sudden movements that could injure the nose.

The first attempt at politzerization should be done by inserting the olive tip into a nostril, getting a good seal but not striking the vestibule or septal walls. The opposite naris is occluded, and the patient is instructed to repeat K-K-K-K-K, loudly and sharply, as a one second burst of air is delivered. A characteristic soft palate flutter sound is heard if the procedure is performed correctly.

If no results are obtained with this technique, the patient is instructed to swallow, and as the thyroid notch raises up, air pressure is again applied in the nose. For people who have trouble with a dry swallow, a sip of water may be given. In the low-pressure chamber, this method is most often used to get maximum opening of the Eustachian tube. It must be remembered that with the water technique, prolonged or high pressure might cause damage to the tympanic membrane with even a remote possibility of damage to the round window membrane and inner ear. As it is important to look at the patient's tympanic membranes before inflation, it is equally as important to observe them afterwards to determine the extent or success of the procedure.

A rubber Politzer bag is available in most drugstores and is useful with the swallow technique in children with serous otitis media or where a pressurized air supply is not available.

The use of Eustachian tube catheterization is not recommended in any case. There have been cases of serious injury from improper catheterization.

Acute Infections. When the tympanic membrane is intact, acute middle ear infections are direct extensions of infections in the nose and nasopharynx, frequently set up by improper blowing of the nose.

Catarrhal otitis media produces blockage of the Eustachian tube and middle ear mucosa inflammation, without bacterial invasion. The patient usually develops a fullness or plugged feeling in the ear and may feel as if fluid is present. There is hyperemia of the vascular strip and annulus, and occasionally the entire tympanic membrane may be diffusely hyperemic. There is usually little or no hearing loss or tympanic membrane bulging. Treatment is directed toward relieving discomfort through decongestants and analgesics. Antibiotics are usually not indicated.

Acute suppurative otitis media results when virulent bacteria invade the middle ear space, most frequently as a complication of a cold, influenza, measles, or scarlet fever. Mucopurulence is formed in the middle ear space, and all parts of the middle ear may be inflamed from the Eustachian tube to the mastoid air cells. Deep, sometimes throbbing pain, fever, and a mild to moderate hearing loss develop. Some people occasionally may have dizziness, nausea, or vomiting.

Initial examination of the ear may show tympanic membrane hyperemia and slight bulging, especially in the para flaccida. As the process continues, the bulging and inflammation distort or obscure the normal landmarks on the tympanic membrane. Finally, an area of blanching develops that signals imminent perforation. With perforation, the patient's pain is usually decreased, but drainage may be inadequate.

Otorhinolaryngology

Treatment should be initiated as soon as possible with an adequate dose of antibiotics, most often one of the penicillin groups. Medication should be continued for seven to ten days to assure complete eradication even in the mastoid cells. Antihistamine decongestant or plain decongestant medication by mouth is prescribed. Control of pain, hydration, and rest are also very important.

If perforation appears to be imminent, it is wise to do a myringotomy (Figure 8-1) to assure adequate drainage and clear perforation that heals more rapidly. If the tympanic membrane ruptures spontaneously, suction cleaning should be done, and if the drainage area is inadequate, consideration should be given to enlarging it by myringotomy. The draining ear should be cleaned frequently to prevent chronic complications. Topical medication is only used in large perforations or when an external otitis is present or develops from the drainage.

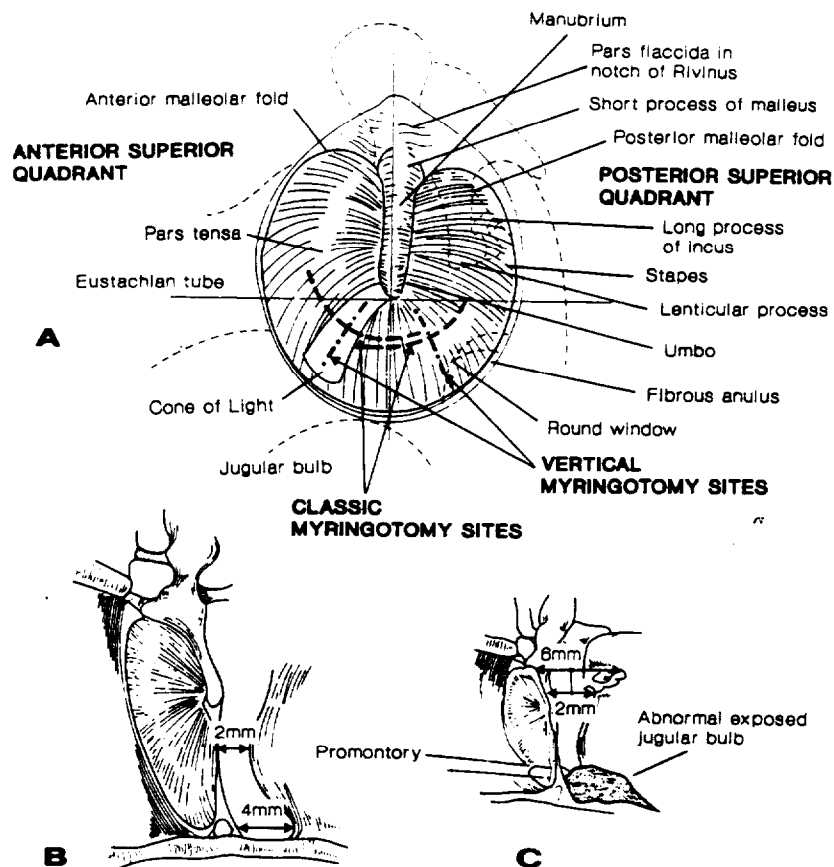

Figure 8-1. Middle ear anatomy and myringotomy sites (A adapted from and B and C from Saunders & Paparella, 1968, published by permission of The C.V. Mosby Co.).

In the management of a chronic draining ear, one has two objectives: First, attempt to control or clear the infection, and second, prevent formation of a cholesteatoma or mastoiditis that might lead to further destruction of hearing, labyrinthitis, meningitis, lateral sinus thrombosis, or brain abscess.

The principles of treatment are meticulous cleaning of the canal perforation and middle ear, removal of granulation tissue, and control of the infection with both systemic and topical antibiotics. Neomycin-Cortisone suspension or Garamycin ophthalmic solutions may be introduced into the middle ear. One technique is to fill the canal with the solution and gently compress the tragus into the meatus while swallowing. If the otorrhea is not too heavy, antibiotic powders may be insufflated, or the older powder preparations, such as Sulzberger's one percent iodine and one percent boric acid, are often effective. For thick drainage and debris, it may be necessary to irrigate with a one and a half or two percent acetic acid solution. The area should be suctioned clean and dry before using the antibiotic drops or powders to increase their effectiveness.

The Inner Ear

Anatomy. Situated medial to the middle ear entirely within the petrous portion of the temporal bone lies the inner ear. It is composed of dense, compact bone two to three millimeters thick, forming the osseous labyrinth. This is divided into semicircular canals, vestibule, and cochlea. Within the bony labyrinth is a membranous counterpart. The supporting fluid outside of the membranous labyrinth is perilymph. It is somewhat similar to cerebrospinal fluid and is high in sodium content. The fluid inside the membranous labyrinth, endolymph, has a high potassium content.

The cochlea is a two and a half-turn coil about a central core called the modiolus, with the apex pointing anteriorly and laterally. There are three compartments. The first two, the scala vestibuli associated with the oval window and the scala tympani associated with the round window, contain perilymph and are joined at the apex of the cochlea through the helicotrema. The third or central compartment is the scala media or cochlea duct, containing endolymph. It contains the neural end organ of hearing, the organ of Corti, which rests on the thick basilar membrane that separates this compartment from the scala tympani. The delicate Reissner's membrane separates the scala media from the scala vestibuli. The organ of Corti contains about 24,000 hair cells arranged throughout the cochlea as a single row of inner cells and from three to five rows of outer cells. Between them, they form a somewhat triangular tunnel of Corti that has its own slightly different fluid, Cortilymph. It is known that high frequency sounds stimulate the hair cells near the vestibule, and low frequency sounds stimulate those near the apex. The area of the promontory of basilar turn of the cochlea is stimulated by frequencies in the range of 3000 to 5000 Hz; it appears

to be the most vulnerable to acoustic trauma, probably from the shearing force in the fluid so near the stapes footplate and the beginning curve in the scala.

Trauma. Temporal bone fractures are, for the most part of two types. The longitudinal or middle fossa fracture that parallels the long axis of the petrous pyramid is usually due to forces applied to the temporoparietal region. The middle ear is always damaged. The tympanic membrane is torn and bleeds. The labyrinthine capsule is usually spared, as is the facial nerve. Longitudinal temporal bone fractures are four times more frequent than the transverse variety. The transverse or posterior fossa fractures usually result from forces applied to the occipital or occipitomastoid region. There is essentially a fracture of the labyrinth that spares the middle ear. There may be hemotympanum, but rarely rupture of the tympanic membrane. Usually, there is both cochlear and vestibular function loss, and the facial nerve is damaged in the internal auditory meatus or horizontal portion. Only sterile ear instruments should be used for examination, and dry ear precautions must be taken.

Initial treatment should include cranial checks, prophylactic antibiotics, and a complete neurological evaluation. The patient should be moved to the care of a neurosurgeon/otologist as soon as his condition permits. A baseline audiogram is valuable if the patient's condition permits.

Barotrauma. In the past few years, an increasing number of cases of barotrauma to the inner ear have been reported from the diving community, and several cases of proven rupture of the round window membrane have been reported or evaluated at the Naval Aerospace Medical Institute (NAMI). These have been associated with overly aggressive use of the Valsalva maneuver to clear what the patient thought was an ear block. In reality, the problem was an over-inflated middle ear and distended tympanic membrane, which gives a similar blocked feeling, but usually has no pain. When the round window membrane ruptures, there may be variable degrees of tinnitus and persistent or positional vertigo, often with nausea and vomiting. Calorics are usually diminished on the involved side, and a sensorineural hearing loss, often across the board, is present with poor discrimination of words. A perilymph Fistula (PLF) may develop at the window also.

The key to successful treatment is early suspicion and diagnosis by the flight surgeon and immediate repair by the otologist. Most complete recoveries have had repairs within 48 hours. The flight surgeon is reminded that a quick, simple tuning fork test will separate nerve loss from a conductive loss.

Sudden Idiopathic Hearing Loss. Apoplectic onset of hearing loss is rare, but it is known to oc-

cur. It is usually unilateral and often associated with transient vertigo and persistent tinnitus. Therapy must be instituted within 48 hours to be most effective.

There have been three likely causes proposed: (1) occlusion of the internal auditory artery by spasm or thrombosis, (2) subclinical mumps, and (3) a single episode of Meniere's resulting in permanent loss of cochlear function.

A "shotgun" treatment regimen is most effective as follows:

1. Mandatory bed rest of seven to ten days.
2. Donnatal or tincture Belladonna q.i.d.
3. Nicotinic acid flushing q.i.d.
4. Histamine vasodilation using 2.75 mg of histamine in 200 ml of five percent dextrose in water I.V. at a rate to cause flushing, but not cause headache or significant drop in blood pressure.
5. Dextran, 500 cc per day (not with histamine).
6. Systemic steroids, such as prednisone 60 mg. daily x seven days, tapered to zero over another seven days.

Hearing threshold and speech testing are done at regular intervals, initially q.o.d., then at longer intervals in the ensuing weeks and months. Most patients have some residual hearing loss. Aviators must be considered on an individual basis for return to duty. This is mostly determined by the amount of hearing deficit, the completion of an extensive workup for tumor and neurological or other disease, and discontinuance of maintenance medication, such as histamine and nicotinic acid.

Nystagmus

The search for the presence or absence of spontaneous or positional nystagmus is an integral part of the otoneurological examination and the fitness for duty examination.

Nystagmus is called right or left according to the direction of the rapid eye movement or quick component. When nystagmus is provoked only in the direction of the quick component, it is

termed “first degree”. When nystagmus is also noted in forward gaze, it is “second degree”, and with nystagmus present in all directions of gaze, it is “third degree”. Nystagmus is further categorized as vertical, oblique (rare), horizontal, or rotatory. Proper evaluation calls for observation of the eyes in the right, left, upward, downward, and primary positions. If the patient is asked to look too far on lateral gaze, a few flicks of nystagmus are frequently seen and are a normal phenomenon of accommodation. After the test for spontaneous nystagmus, tests for positional nystagmus are carried out with the patient’s eyes in the straight ahead position. The method most often used is that of Cawthorne, Dix, and Hallpike. The patient is rapidly placed supine with the head hanging over the edge of the table, and the eyes are observed for 60 seconds. The patient is then raised up and then returned to the hyperextended position with the head in one direction, again for 60 seconds. The procedure is repeated in the opposite direction. Nystagmus, if present, should be immediately recorded as to type, direction, amplitude, and intensity. The position should be held until the nystagmus subsides; however, if it persists longer than 60 seconds, it is considered permanent. In older persons where vertebral artery occlusion may be the cause of the nystagmus and vertigo, one must use caution and good judgement to assure that the patient is not left in this position too long.

Unidirectional nystagmus is usually of peripheral origin and occurs in the horizontal plane. The quick component is toward the uninvolved ear. Caloric response is usually hypoactive or absent. When caloric tests are normal, unidirectional nystagmus may be of central origin. The nystagmus is usually the strongest, and often only present, when gaze is directed toward the side of the quick component (first degree). The diagnostic characteristics of nystagmus are given in Tables 8-1 and 8-2.

Multidirectional nystagmus is suggestive of central involvement (i.e., a lesion anywhere in the brain). Most often, however, it results from a posterior fossa lesion where the bulk of the vestibulocerebellar units are located. The quick component is usually permanent and toward the side of the lesion. True vertigo is less frequent, and ataxia may be evident in central lesions. Table 8-3 provides a listing of diagnostic criteria helpful in differentiating between central and peripheral vertigo.

Drugs often produce characteristic nystagmus. Opium and Demerol produce a vertical downward nystagmus. Positional nystagmus is found with barbiturates and alcohol. Any patient who demonstrates a spontaneous positional nystagmus with no other abnormality of labyrinthine function should be checked for barbiturate ingestion.

A most interesting and characteristic positional nystagmus is seen with alcohol intoxication. The nystagmus is typically in two phases and is often recorded as PAN (positional alcohol

nystagmus) I and II. As little as 0.02 percent blood concentration may produce both phases. Phase I begins about 30 minutes after ingestion, as the blood alcohol peaks, and lasts approximately three and a half hours. The nystagmus is always in the direction of the gaze or toward the position of the head, for example, a right-beating nystagmus appears with right gaze, head turned to the right side or if the right of the patient's head is down in the lateral position. There is a gradual diminution after the peak and an intermediate period of about 1.7 hours in which there is no nystagmus. Approximately five hours after the initial ingestion, PAN II begins, and the nystagmus is in the opposite direction of the gaze or lateral head position and persists for several hours after the blood alcohol level has disappeared. PAN II nystagmus is greatest when the "hangover" symptoms are greatest.

Table 8-1

Spontaneous Vestibular Nystagmus

	Peripheral (Labyrinth, Vestibular Nerve)	Central (CNS)
Form	Horizontal-rotatory	Horizontal; vertical; diagonal; rotatory; multiple; retractorius; convergence; pendular; alternating
Frequency	½-6/sec.	Any frequency, usually low or variable at long intervals (weeks to months)
Intensity	Decreasing intensity	Constant
Direction of fast component	Towards "stimulated" labyrinth or away from "destroyed" labyrinth	Towards side of CNS lesion
Duration	Minutes to weeks	Weeks to months
Dissociation between eyes	None	Possible
Vertigo	Present	Present or absent
Cochlear signs	Frequently present	Seldom present
Autonomic nervous system signs	Definite	Less definite or absent
Past pointing and falling	Direction of slow phase	Direction of fast phase

(Toglia, 1967, published by permission of Grune & Stratton, Inc.)

Table 8-2

Differences Between Peripheral and Central Positional Nystagmus

	Peripheral	Central
Latency	2 to 20 seconds	None
Persistence	Disappears within 50 seconds	Lasts longer than one minute
Fatigability	Disappears on repetition	Repeatable
Positions	Present in one position	Present in multiple positions
Vertigo	Always present	Occasionally absent, and only nystagmus present
Direction of nystagmus	One direction	Changing directions in different positions
Incidence	85 percent of all cases	10 to 15 percent of all cases

(Spector, 1967, published by permission of Grune & Stratton, Inc.)

Table 8-3

Differentiation of Central from Peripheral Vertigo

	Peripheral (Labyrinth, Vestibular Nerve)	Central (CNS)
Hallucination of movement	Definite	Less definite
Onset	Usually paroxysmal	Seldom paroxysmal
Intensity	Usually severe	Seldom severe
Duration	Minutes to weeks	Weeks to months
Influenced by head position	Frequently	Seldom
Nystagmus	Present	Present or absent
Autonomic nervous system symptoms	Definite	Less definite or absent
Tinnitus	Frequently present	Seldom present
Deafness	Frequently present	Seldom present
Disturbances of consciousness	Seldom present	More frequently present
Other neurological signs	Usually absent	Frequently present

(Toglia, 1967, published by permission of Grune & Stratton, Inc.)

Diseases or Clinical Syndromes of Otological Origin

The majority of cases of dizziness which the flight surgeon will see associated with disease or injury of the inner ear or eighth cranial nerve are acute labyrinthitis, epidemic vertigo, vestibular neuronitis, Meniere's disease, acoustic neuroma, benign paroxysmal positional vertigo, and trauma. These must be differentiated from the many causes of dizziness or vertigo (Table 8-4).

Labyrinthitis. Labyrinthitis has many classifications, but, in general, it is serous, diffuse, destructive, or toxic. Serous and diffuse destructive labyrinthitis are associated with otitis media, cholesteatoma, or ear surgery. When the disease is of the serous type, the vestibular and cochlear functions are depressed, with the vestibular symptoms usually preceding the cochlear depression by a few hours to several days. There is usually spontaneous nystagmus to the opposite ear, nausea and vomiting, true vertigo, ataxia, past-pointing, and loss of hearing.

In patients with chronic ear disease, especially cholesteatoma, a fistula test should be performed by exerting pressure and then suction using a pneumo-otoscope. Production of nystagmus and vertigo indicates the presence of a labyrinthine fistula. An acute, initially severe, and sudden onset of symptoms may be associated with the erosion into the labyrinth; however, in cholesteatoma, the lining or sac protects the labyrinth, and only quick head movements or pressure applied in the canals cause vertigo in many cases. Patients who have had ear surgery or manipulation of the stapes may have all the usual findings, except nystagmus.

In isolated serous labyrinthitis, there is usually return of labyrinthine function over weeks or months. If any fistula is suspected or injury occurred in surgery, systemic antibiotics are indicated. With fistulas, there is often a permanent nerve-type hearing loss, and some patients have chronic positional vertigo.

Suppurative labyrinthitis results in violent and sudden onset of vertigo, disturbed equilibrium, nystagmus, and vomiting. Cochlear and vestibular responses are lost. Complications such as meningitis or brain abscess lead to toxic symptoms of headache, malaise, and fever. Vigorous therapy with antibiotics and surgery must be instituted, and some small mortality can be expected even with treatment. For those who recover, there is usually no recovery of the cochlear or vestibular responses, and three to five weeks are required for compensation. Return to a flying status is not recommended, except in the mildest cases. It is often impossible to be sure of complete eradication of disease, and there is questionable compensation of loss of hearing and labyrinthine function and occasional residual ataxia.

Table 8-4

Causes of Dizziness and/or Vertigo

<i>Otological</i>	<i>Neurological</i>
Impacted cerumen	Degenerating and demyelinating diseases, especially multiple sclerosis
Trauma to the inner ear or eighth cranial nerve (commotio labyrinthi)	Posterior fossa lesions
Dysfunction of the eustachian tube	Fractures, cystic arachnoiditis, syringobulbia, platybasia and Arnold-Chiari malformations
Acute otitis media	Neoplasms and subdural hematomas
Labyrinthitis	Supratentorial lesions with displacement of the brainstem
Labyrinthine fistula	Migraine-like syndromes
Bilateral nonfunctioning equilibrial labyrinths	Convulsive disorders (vestibular epilepsy, vertiginous epilepsy)
Motion sickness	Temporal lobe lesions with irritation of cortical vestibular areas
Ménière's disease	Toxic-infectious conditions
Lermoyez syndrome	Aseptic meningoencephalitis
Vestibular neuronitis	Brain abscess
Vasculitis involving the internal auditory artery or vestibular emissary veins	Common viral diseases such as mumps, measles, whooping cough
Tumors of middle ear and inner ear	Vascular, including atherosclerosis, thrombosis, embolic occlusion, and hemorrhage, especially in vessels to the brainstem.
Ototoxic drugs	
"Focal infection" from tonsils, adenoids, periapical tooth abscesses, and chronically infected sinuses	
Sinusitis, acute or subacute	
<i>Systemic</i>	<i>Ophthalmological</i>
Allergic reactions involving the inner ear	Nonconcomitant strabismus
Dizziness of the aged due to indeterminate vascular cause or end-organ degeneration due to aging process	Refractive errors
Cardiac diseases	Optokinetic vertigo
Hypertension (paroxysmal)	
Hypotension (syncope)	
Hyperactive carotid reflex	
Blood dyscrasias (anemia, leukemia, lymphomas, reticulosis, polycythemia, purpura)	
Cogan's syndrome (nonsyphilitic interstitial keratitis with vestibulocochlear symptoms—panarteritis nodosa)	<i>Psychogenic</i>
Episodes of hypoglycemia	Tension—anxiety state
Hypocortoadrenalism	Conversion reactions
Cervical myalgia	Neuroses (agoraphobia, claustrophobia)
	Hyperventilation syndrome

(Williams, 1967, published by permission of Grune & Stratton, Inc.)

Toxic labyrinthitis is one of the most common types seen, and a great deal of disagreement remains about its classification. The etiology ranges from acute febrile diseases to toxic or chemical substances to idiopathic. The most common characteristic is whirling vertigo with gradual onset reaching a maximum in 24 to 48 hours, and at its height, there may be nausea and vomiting. There may be no cochlear or vestibular abnormalities in those cases associated with or following acute febrile illness, but when associated with drugs, either system may be affected. Usually there is recovery from vertigo in three to six weeks.

Most commonly, toxic labyrinthitis is associated with pneumonia, cholecystitis, influenza, allergy, extreme fatigue, overindulgence in food or alcohol, and certain ototoxic drugs (Table 8-5). Palliative treatment with antivertiginous drugs (Table 8-6) and bed rest is helpful. The physician should always be aware of a missed or changing diagnosis with these patients. They should not be dismissed with the "they always get well" attitude.

Table 8-5
Ototoxic Drugs

Toxic to Cochlea or Labyrinth	Causing the Symptom Dizziness	
Chloroquine Dihydrostreptomycin Ethacrynic acid (Edecrin) Furosemide (Lasix) Gentamicin Kanamycin Neomycin Quinidine Quinine Salicylates Streptomycin Tobramycin Vancomycin Chloramphenicol (topically)	Antihypertensives Barbiturates CNS depressants Estrogens Phenothiazines Phenylbutazone Oral contraceptives	
Antibiotic Ototoxicity		
Vestibular Toxicity	Drug	Cochlear Toxicity
(Least) ↓ (Most)	Neomycin Kanamycin Gentamicin Streptomycin	(Most) ↑ (Least)

Table 8-6

Antivertiginous Drugs

Generic Name	Trade Name	Hours of Effect	Adult Dose (mg)	Availability
Cyclizine	Marezine	4	50	Tablets: 50 mg Parenteral injection: 50 mg/ml Suppositories, pediatric: 50 and 100 mg
Dextroamphetamine	Dexedrine	8	5-10	Tablets: 5 mg Spansules: 5, 10, and 15 mg Elixir: 5 mg/tsp.
Dimenhydrinate	Dramamine	6	50	Tablets: 50 mg Liquid: 12.5 mg/4 ml Parenteral: 50 mg/ml Suppositories: 100 mg
Diphenhydramine	Benadryl	6	50	Capsules: 25 and 50 mg Elixir: 12.5 mg/5 ml Parenteral: 10 and 50 mg/ml
Diphenidol	Vontrol	4	25 50	Tablets: 25 mg Ampules: 2 ml (20 mg/ml) Suppositories: 25 and 50 mg
Meclizine	Antivert	12	50	Tablets: 12.5 and 25 mg; chewable, 25 mg
Promethazine	Bonine	12	50	Tablets, chewable: 25 mg
	Phenergan	12	50	Tablets: 12.5, 25, and 50 mg Syrup: 6.25 and 25 mg/5 ml Suppositories: 25 and 50 mg
Scopolamine	Donphen	4	0.2-1	1 or 2 tablets 3 or 4 times/24 hr., 6 μ g/tablet with phenobarbital, 15 mg., and atropine, 0.02 mg

Epidemic Vertigo. Although to a great extent this disease may be of central origin, it is important to differentiate it from other vertiginous conditions, and this can often only be done by exclusion. Characteristically, symptoms are acute onset of severe dizziness, nausea, vomiting, a slight fever, headache, and asthenia, with a duration of several weeks to months. Recovery, however, is usual. There is usually an epidemic character to the disease, and it is associated with either an upper respiratory infection or gastroenteritis. Caloric and audiological tests usually are normal, but spinal fluid may show some lymphocytic cells. Cases with gastrointestinal symptoms are more frequent in mid-January, and those with upper respiratory symptoms occur in the autumn. Laboratory tests are of little value.

Treatment is supportive, with variable help from antivertiginous and antinausea drugs such as Dramamine, Vontrol, Torecan, and Tigan. These patients should be able to return to flying within one month after all symptoms have ceased.

Vestibular Neuronitis. Vestibular neuronitis is characterized by an attack of sudden, debilitating vertigo, nausea, vomiting, and spontaneous nystagmus. In most cases, there appears to be an antecedent or concomitant infection in the upper respiratory tract, maxillary sinuses, or teeth. The cochlea is spared, but one or both of the labyrinths have abnormal calorics. Vestibular symptoms decrease somewhat after a few hours, but they remain fairly severe for the first week, slowly decreasing over the next four to eight weeks. About 70 percent of these patients have permanent, decreased caloric function.

Management is directed toward supportive treatment of the symptoms and an aggressive workup to rule out other possible diagnoses. Vestibular neuronitis is a self-limiting disease, although return to work may require from three to twelve weeks. Generally, an aviator is permanently grounded for military flying because of the sudden debilitating nature of the attacks which can be recurrent even as long as four years after the initial attack.

Meniere's Disease. Although much disagreement persists as to whether this is a disease or a symptom complex, and its etiology is still unknown, there is usually the classical triad of episodic vertigo, tinnitus, and deafness. The average age of onset is 44 (Cawthorne & Hewlett, 1954), and it is predominantly unilateral, with only about ten percent of the patients having bilateral involvement.

The onset of symptoms is insidious, usually with a sensation of dullness or fullness in the ear, and an initial fluctuation in hearing of 10 to 30 dB, usually in the low tones. The hearing improves somewhat between attacks, but it continues to deteriorate as time goes on. There may be increased sensitivity to sound, or music may sound distorted. Tinnitus, varying from a whistle to a roar, develops, followed by a turning or whirling vertigo that may lead to nausea, vomiting, and even prostration. Any head movement aggravates the condition, with the vertigo lasting several hours. Some patients can have fleeting attacks lasting several minutes, and still others have attacks lasting a week or longer and may take months to regain normal equilibrium.

Besides the fluctuating hearing, spontaneous nystagmus, usually rotary and often direction-changing, and a direction-fixed, positional nystagmus are the most common findings. The caloric reaction is usually abnormal. Aside from the hearing loss, Meniere's patients frequently have recruitment and diplacusis, low threshold discomfort, and low discrimination scores. Tone decay and a Type II Bekeasy are present. A fairly reliable diagnostic test is the glycerin test, where a pa-

Otorhinolaryngology

tient ingests 1.5 gm/kg body weight of glycerol mixed with equal parts of normal saline and a few drops of lemon juice. Audiograms are taken immediately and at one, two, and three hours after ingestion. A positive test is said to be an improvement in hearing of 15 dB in any one frequency from 250 to 4000 Hz or 12 percent improvement in the discriminating score.

There is no effective, long-term treatment for Meniere's disease. For many years, some physicians have controlled their patients with a neutral-ash, salt-free diet, supplemented with diuretics. Shea (1975) recommends a regimen of bed rest, Valium, low salt, diuretics, and no smoking, plus inhalation of five percent carbon dioxide and 95 percent oxygen for 30 minutes q.i.d. and 2.75 mgm of histamine diphosphate in 250 cc of lactated Ringer's solution I.V. b.i.d. Other drugs, given individually, that are reported to be effective for an acute attack are 1/150 grain Atropine I.V., Valium 10 mgm I.V., and Innovar, which must be administered in the hospital or by an anesthesiologist. Vasodilators, such as nicotinic acid, beta-pyridylcirbinol, Roniacol, or Arlidin, are usually ineffective in Meniere's, as are the antivertiginous drugs. There have been several surgical treatments for Meniere's with some success in a certain percentage of patients. These range from the endolymphatic shunt to destructive labyrinthotomy in the most severe, uncontrolled cases. Patients with a diagnosis of Meniere's are permanently grounded, and only the patient with a rare surgical cure has ever been allowed to fly by the Federal Aviation Agency.

Acoustic Neuroma. An acoustic neuroma is a fairly rare, extremely slow-growing neoplasm that originates on the vestibular portion of the eighth cranial nerve in the internal auditory canal. It constitutes about eight to ten percent of all brain tumors and is most common in the fourth and fifth decade of life. Early diagnosis, which offers the best chance for a surgical cure and the least morbidity and mortality, is often based on a strong suspicion. Symptoms, often difficult to pinpoint but most often present, are steady, unilateral tinnitus, hearing loss, and a feeling of unsteadiness. Some patients have vague complaints of headache, local retroaural discomfort, and facial paresthesia or pain. A significant finding is speech discrimination much more severe than indicated by a pure-tone hearing test.

Diagnostic evaluation should include a complete audiological examination of pure tone and speech, stapedial reflex, and acoustic reflex decay. Stenver's and Town's X-rays are valuable for an initial screen, but CAT scans or MRI are more often necessary. Typically, there is a sensorineural-type hearing loss with poor speech discrimination that is inconsistent with the pure-tone test, absence of recruitment or low small increment sensitivity index (SISI) scores, pronounced tone decay, a type III or IV Bekesy tracing, reduced caloric response, widening of the internal auditory canal, decreased corneal sensitivity on the involved side, and decreased or absent stapedial reflex.

Suspected cases, which are not diagnostic should be kept under the watchful eye of an otolaryngologist or neurologist and not dismissed or forgotten after the initial workup.

Benign Puroxysmal Positional Vertigo. Benign paroxysmal positional vertigo must be differentiated from Meniere's and eighth nerve tumors. In general, onset of nystagmus and vertigo occur when the head moves to a certain position. There usually is a latent period of several seconds, and the nystagmus fatigues with repeated testing. Most cases have normal calorics and audiological examinations. Symptoms abate in about eight weeks, but they may recur or even last for years. There is no treatment except avoidance of the position that creates the nystagmus and vertigo, as well as reassurance to the patient. Pilots should be grounded until all symptoms have disappeared, and each case must be considered on an individual basis.

Rhinology

Nasal and Sinus Physiology

The primary functions of the nose are filtration, warming, and humidification of air; it also subserves the sense of smell, and it is the origin and recipient of numerous reflex areas. The sinuses have no primary function.

Air filtration is accomplished by the vibrissae in the anterior nares and by mucus. Most of the mucous glands are in the nasal mucosa. The mucous blanket is moved by cilia toward the nasopharynx at the rate of five mm per minute. Although amazingly resistant to heat, cold, fumes, dust, and chemicals, the cilia are most vulnerable to drying from inspired dry air, such as central heating or 100 percent oxygen.

Air flow during inspiration is directed over the turbinates to the roof of the nasal cavity and then into the nasopharynx. The air is warmed by heat transfer from the mucous membranes. During expiration, the air makes a loop before exiting the nose anteriorly, allowing for retention of the moisture in the air. The air flow volume is regulated by the changing size of the turbinates.

Bacterial Diseases of the Nose

Vestibulitis. An inflammation of the hair follicles in the nasal vestibule may cause chronic crusting and tenderness of the nasal tip or ala; it is often recurrent. Treatment consists of gentle cleaning of the nasal vestibule and the application of topical antibiotic ointment, usually containing Neomycin, two or three times daily. Ophthalmic ointments work well, but treatment must be continued for two or three weeks after symptoms disappear to prevent recurrences.

Otorhinolaryngology

Furunculosis. Furunculosis of the vestibule is also common and usually associated with digital trauma and nose blowing. A crack in the skin allows the entrance of strep or staph organisms. Most infections localize, but occasionally they may become a spreading cellulitis. Squeezing or incising the area is dangerous, as it may cause spread to the cavernous sinus. Pain and systemic symptoms may be marked. Treatment consists of a “hands off” policy, adequate doses of appropriate antibiotics, hot, moist packs, and good analgesics.

Rhinitis. Rhinitis can develop as a complication of an upper respiratory infection if symptoms last longer than seven to ten days. Thick yellow or greenish nasal drainage, fever, throat and ear pain, and productive cough suggest complications. Excessive blowing of the nose, which forces bacteria into the sinuses and Eustachian tube and traumatizes the sinus orifices, and severe coughing, which strips the cilia from the bronchial lining, are the most common causes.

Treatment should place emphasis on maintaining good nasal and sinus drainage, good tissue hydration, and rest; antibiotics are used for bacterial infections or complications. The penicillins, erythromycin, or the tetracyclines, in order of preference, handle most complications, but cultures should be taken to provide help in resistant cases.

In general, pilots or flight personnel should not fly with a cold. Even a slight amount of nasal congestion and tissue edema may be enough to interfere with pressure equalization of the sinuses and ears, leading to aerotitis, aerosinusitis, or barometric vertigo. The flight surgeon should strongly advise against self-medication and frequently reiterate the many predictable, immeasurable factors, such as level of awareness and performance, that may be affected by disease or medication. The flight surgeon must make individual judgements, depending of the aircraft, aircrewman’s job, type of flight, and medication, when deciding to ground flight personnel. Before personnel are allowed to return to flight status, a careful examination of the ears, nose, and throat should be made. Symptoms are often gone several days before the tissues return to normal and before essential functions return sufficiently to handle the many different and rapid environmental changes associated with flying.

Diseases of the Nose and Sinuses

Allergic Rhinitis. Allergic rhinitis, a very unpredictable and difficult problem in aviation, may be acute or chronic, seasonal or perennial. Common symptoms are nasal obstruction, clear rhinorrhea, sneezing, itching of the eyes, soft palate, and nose, and occasional associated headache, mostly frontal. Some cases of allergic rhinitis are similar to a cold, but they usually last only one or two days or else 10 days and are more frequent than viral upper respiratory infections.

Seasonal allergies are often caused by pollens from grasses, trees, or flowers and last two or three weeks. If a specific allergen is found, desensitization is often effective. After an allergy shot, a pilot is grounded for at least six hours. Perennial rhinitis can be quite variable with no pattern, or it may be nearly constant. Allergies may be caused by house dust, molds, dog dander, wool, feathers, tobacco pollutants, or food. Avoidance, if possible, is the best method of control; however, desensitization may be effective for dusts and molds.

Examination of the nasal mucosa often reveals edema and pallor of the turbinates, especially the inferior turbinates and the anterior tips of the middle turbinates. The turbinates may be so engorged they appear purple. The posterior turbinate tips may protrude into the nasopharynx or become irregular and look like mulberries. Red or inflamed mucosa has also been noted, especially if the allergen is a pollutant.

A basic allergy workup should include the following:

1. History - present, childhood, family.
2. Nasal smear for eosinophiles.
3. Sinus X-rays.
4. Complete blood count.
5. Thyroid function test.
6. Total protein and gamma globulin blood level.

The basic treatment measures are as follows:

1. Take antihistamines, with or without decongestants. Alternating the antihistamine every two weeks is often effective.
2. Cover pillows and mattress with plastic.
3. Cover overstuffed furniture.
4. Eliminate wool from bedding.
5. Remove domestic animals from the house.

Otorhinolaryngology

6. Air-condition the house.
7. Avoid milk and egg products; other foods can be eliminated, one at a time, a week apart.
8. Use nonallergenic cosmetics.

Severe allergy attacks may require a short course of systemic steroids for control. Milder cases that create obstruction of the nasal airway and sinus orifices can often be helped by topical steroids in an aerosol form, such as Beclamethazone, Flunisolide or nasal cromolyn sodium.

Nonallergic Rhinitis. Nonallergic rhinitis, often included under the term of vasomotor rhinitis, has as the most common symptoms chronic, intermittent, often alternating nasal stuffiness or obstruction, and postnasal drip. In the course of treatment, it is important to rule out allergies, to explain the physiology of the nose to the patient, and to prevent the overuse of nose drops or inhalers that may cause a rhinitis medicamentosa. Once rhinitis medicamentosa develops, it can only be cured by complete abstinence from nose drops. In about three weeks, the normal reflex activity should return. Septal deviations should be corrected if they are a factor in obstructions. Humidification of the house or bedroom, or the use of Proetz solution or ointments to prevent drying of the mucosa is often helpful. Thyroid function may be a factor in some cases; for borderline hypothyroid states, thyroid extract or Cytomel has been effective. Certain emotional states cause nasal symptoms, and they often respond when this problem has been explored or treated. Rhinitis of pregnancy usually responds to no treatment except delivery. Certain antihypertensive and birth control pills may cause nasal congestion; decrease or change in the drugs often improves or cures the problem. Topical steroids have been helpful in some cases.

Polyps and Polypoid Degeneration. When the nasal mucosa, and in some cases the sinus mucosa, reacts to allergies or inflammation, edema develops due to increased capillary permeability and transudation of fluid into the cell and extracellular spaces.

Air conditioners may contain much dust and mold, causing more trouble for a person with allergies to these substances. Electrostatic filters may do a better job, but may produce ozone which is toxic. If the first outlet is eight to ten feet from the unit, it is usually safe. Humidification is good for the dry nasal mucosa but it also increases the growth of molds in the house.

The mucosa appears “waterlogged” or “intumescent”. Over a period of time, with the help of gravity, this tissue may elongate to form nasal polyps, especially in the region of the middle meatus and maxillary sinus ostia. In some cases, the anterior tip of the middle turbinate may just remain edematous, and this condition is called polypoid degeneration, rather than a polyp. The tissue may lose some of its cilia and is replaced with goblet cells.

Polyps and polypoid degeneration may obstruct the sinus ostia leading to acute and chronic sinus disease or sinu blocks and, therefore, should be removed when obstructive. Small, or single, nonobstructive polyps need not be removed unless they enlarge. Occasionally, polyps are found within the maxillary sinus; these polyps eventually move out of the sinus ostium and into the nasopharynx, where they expand in size. These polyps are called antrochoanal or choanal polyps, and their removal requires a Caldwell-Luc antrostomy to remove the base and prevent recurrence. Polyps in the maxillary sinuses are disqualifying for aviation candidates, as is nasal polyposis. A possible exception can be made for a single, small polyp on one side in an asymptomatic, nonallergic candidate. Recurrence of polyps after removal is common; this is especially true when the disease remains in the ethmoid sinuses. In some cases, the use of short courses of broad spectrum antibiotics and topical steroids may reduce the size of the polyps. A common dose schedule is two sprays in each nostril, twice daily for one week, then one spray in each nostril twice daily for four days, finishing with one spray daily in each nostril for the remainder of the week or longer, if desired. The use of topical steroids may be irritating to the mucosa; otherwise there are essentially no side effects.

Epistaxis

The majority of nosebleeds are caused by trauma and occur from the vascular plexus on the anterior septum, known as Kisselbach's plexus or Little's area. Common causes are air drying, violent sneezing or blowing the nose, and picking the nose. Severe bleeding, especially high anterior and posterior bleeding, occurs from the ethmoid artery, a branch of the internal carotid, and the sphenopalatine artery, a branch of the external carotid artery.

In general, treatment of simple anterior bleeding should first be direct pressure, for at least five or ten minutes, against the anterior septum. Pledgets of cotton moistened in a vasoconstrictor, such as one percent Neo-Syneprine, one percent epinephrine, or one to four percent cocaine, along with pressure, are even more effective; large clots should be gently suctioned away. If bleeding is controlled, the bleeding site may be cauterized with 25 to 50 percent trichloroacetic acid, five percent chromic acid, or silver nitrate in a 50 percent solution or on a stick applicator. These solutions should be applied with a small, moist applicator under direct vision. Anterior bleeding sites not controlled by direct pressure or chemical cautery should be infiltrated with Xylocaine and epinephrine, using both the tissue wheal and the epinephrine effect for control. The site may then be cauterized by chemical or electrocautery; deep burns or cauterization of adjacent structures, such as the ala or vestibule, must be avoided. If the coagulated fluid and blood stick to the tip of the cautery and are pulled off with the coagulum, the bleeding may restart. In those cases where bleeding cannot be controlled, one might attempt cautery with a suction tip electrode; if this fails, the nose can be packed with Vaseline and antibiotic ointment impregnated

in half-inch selva gauze. It is best to pack both sides to prevent loss of the pack by shifting of the septal cartilage from a one-sided pressure. The pack should be left in place for at least 24 hours, but usually never more than 72 hours. All raw or cauterized surfaces should be lightly covered with an antibiotic ointment, and a small piece of compressed Gelfoam over the anterior septum further protects against air trauma. The ointment application should be repeated three or four times a day.

Posterior bleeding, usually in the older age group, is a serious condition, and, if coupled with hypertension, it requires aggressive medical and rhinological management. The patient should be admitted to sickbay, sedated, and kept in a head-elevated position. After vasoconstrictor and topical anesthetic application to both nasal passages, an attempt can be made to control the posterior bleeding by the use of a specifically designed postnasal balloon, or a common, 15 cc-size Foley catheter. The balloon is checked before insertion, then it is passed along the floor of the nose, and when it is in the lower nasopharynx, the balloon is filled with about 5 cc of water. It is then drawn back up against the posterior choana and further filled to the point of tolerable discomfort to the patient. Anterior packing is inserted bilaterally with fixation of the catheter to the lip or against the packing, but never against the ala or septum to prevent pressure necrosis. The posterior pharynx is checked hourly for bleeding, and the hemoglobin and hematocrit are monitored according to the amount of oozing or bleeding; blood typing and cross matching are advisable. Blood coagulation studies are usually done, but it is unusual to see only nasal bleeding with abnormality of the clotting mechanism. A patient with a posterior nasal pack or balloon is never sent home. He should be closely monitored because of the possibility of a nasovagal reflex action when the nasopharynx is packed, that might lead to apnea or hypoxia. Uncontrolled bleeding of the ethmoidal arteries requires ligation in the orbit or, as a last resort, an internal carotid ligation. Uncontrolled sphenopalatine artery bleeding requires ligation through a transmaxillary sinus approach, or ligation of the external carotid in the neck.

Barotrauma to Sinuses

Aerosinusitis results when equalization of pressure between the sinus cavities and the atmosphere is prevented by obstruction of their orifices. There are numerous causes, but heading the list are the common cold and allergies. Other causes are anatomical defects, infection, and polyps.

As an aviator goes to altitude, the outside pressure decreases, and discomfort may be felt in the obstructed sinus. It is usually not severe, however, and most often air forces its way out past the obstruction. When the aviator descends, the pressure in the obstructed sinus remains less than the surrounding pressure, creating a vacuum effect on the delicate, thin, mucosal lining and resulting

in pain that is often severe. Some fluid may be drawn into the cavity, but the more serious complication is pulling away of the mucoperiosteum, with formation of a hematoma. Sinus blocks occur most often in the frontal sinus (70 percent), and the aviator must be grounded until the hematoma resolves, and the ostium is patent. This may require three weeks to three months. For this reason, anyone suspected of a sinus block should have sinus X-rays to determine the extent of injury and then should be followed at approximately three-week intervals, until clear.

Treatment of the acute block is as follows:

1. Stop descent in aircraft or low-pressure chamber, if possible, and return to altitude for pain relief.
2. If available, spray the nasal passage with a vasoconstrictor nasal spray (nose drops).
3. Do the Valsalva maneuver or use the Politzer method.
4. Make a slow descent equalizing pressure with the above maneuvers.
5. Place patient on antihistamine-decongestant or decongestant therapy.
6. Take screening Water and Caldwell sinus X-rays.
7. If an upper respiratory infection is present, treat with antibiotics.
8. Control severe pain with Codeine or Percodan.
9. If a frontal sinus hematoma is present, ground the aviator for at least three weeks. With no apparent X-ray pathology, the aviator should be grounded for at least 72 hours, or until any nasal symptoms have been cleared. Recurrent trauma may result in mucocele formation, requiring a major surgical procedure and permanent grounding.

Sinusitis

The majority of acute sinusitis cases follows an acute upper respiratory infection, like the common cold, and they are often the result of improper nose blowing. Another cause, which may have a more rapid onset, is swimming or diving; occasionally, an upper molar tooth abscess breaks into the maxillary antrum. The extent and persistence of the infection depends on two major physiological principles, ventilation and drainage; the treatment is directed toward these prin-

Otorhinolaryngology

ciples. The most common bacterial causes are the Gram-positive cocci.

Acute suppurative sinusitis usually has symptoms of nasal congestion and pressure or pain over the involved sinus. Toxicity is usually mild, except in cases of pansinusitis when the frontals or sphenoids are involved. Pus draining from the middle meatus or above the middle turbinate, pain and pressure over a maxillary or frontal sinus, and decreased transillumination may be sufficient to make a diagnosis. The X-ray is indispensable, however, in determining the extent of the disease, fluid levels, and response to medication, all of which may indicate the proper approach to treatment.

Maxillary sinusitis, usually has the least toxicity, but a persistent fluid level or pain after 48 hours of adequate antibiotic therapy suggests the need for irrigation of the antrum, either through the canine fossa or through the thin, bony wall of the inferior meatus. The maxillary sinus mucosa has great reparative power; after removal of the pus by irrigation, it may clear within a few days. If the antral infection is dental in origin, it is useless to attempt a cure without treatment of the offending tooth.

Ethmoid sinusitis is probably the most common infection. Due to the proximity of the ethmoid sinuses to the frontal and maxillary sinuses, ethmoid sinusitis either causes or is associated with the infections in those sinuses also. Ethmoid infections usually cause more inflammation and mucosal swelling. Pain may be near the root of the nose or frontal region. Edema of the lower lid is often present in children. Orbit involvement may result in painful eye movement due to a periostitis about the pulley of the superior oblique muscle or, in the case of rupture into the orbit, proptosis.

Frontal sinusitis usually is associated with toxicity, frontal headache, often in mid-morning to late afternoon, tenderness to percussion over the sinus, or pressure on the floor in the supra-orbital region; swelling of the upper eyelid may be highly suggestive. Treatment should be vigorous to prevent osteomyelitis of the skull or fistulas that lead to complications, such as soft tissue or sinus cavity abscesses, meningitis, brain abscess, and even death.

Sphenoid sinusitis is uncommon, but it may result as a direct extension of infection in neighboring sinuses, nasal mucosa, or the nasopharynx. The symptoms are variable, but they may consist of a deep, boring, occipital or parietal headache with inability to concentrate, fever, malaise, and anorexia. Rupture or osteomyelitis from sphenoid infection leads to rapidly fatal meningitis or cavernous sinus thrombosis. Diagnosis can usually only be made by suspicion and X-rays, using proper contrast in the lateral and submental vertex positions; fluid levels will only be seen if the X-rays are taken in the upright position. These patients require high doses of intravenous antibiotics and emergency surgical intervention.

Since the cardinal principle of treatment in sinus infections is ventilation and drainage, the following treatment is suggested:

1. The nasal mucosa must be protected from drying. The patient must be kept hydrated, and, in some cases, use of a humidifier or vaporizer may help.
2. An oral decongestant may be used alone or with an antihistamine. Antihistamines may make secretions too thick or the mucosa too dry, so it is often helpful to use a mucous-thinning medication, such as glycerial-guiacolate.
3. Antibiotics are given orally in adequate doses for at least seven days in most uncomplicated cases, but in pansinusitis or cases of moderate to severe toxicity, and especially in frontal or sphenoid involvement, intravenous antibiotics are necessary. Most organisms are sensitive to penicillin or erythromycin, but it is strongly recommended that a culture be taken from the turbinates and the meatuses. Be sure not to touch the nasal vestibule and hairs, as these areas may have different predominant organisms. The nasopharynx is another area from which to obtain a culture of prevalent sinus drainage.
4. Bed rest, hydration, and adequate pain medication are important in patients with toxicity.
5. Antral irrigation, either through the natural ostium or the canine fossa or inferior meatus puncture approach, is indicated for persistent pain or fluid levels after 48 hours of antibiotic therapy. Persistent swelling, and pain in the frontal sinus region, in spite of intense therapy, may signal the need for a frontal sinus drainage, usually done by trephine through the sinus floor. A rubber or plastic tube dram is sutured in place to allow irrigation and drainage until the natural ostium drainage is reestablished.
6. Daily mucosal shrinkage and gentle nasal suction cleaning may help promote drainage.
7. Local heat is often helpful, not only as comfort to the patient, but to increase the vitality of the mucosa.
8. Persistent or subacute ethmoid disease may respond to Proetz displacement irrigation, or Grossan nasal irrigation.
9. Acute sphenoid infection with toxic signs is an emergency life-threatening situation requiring immediate hospitalization and surgery, so one should always be alert to this disease, by itself or as a complication from the other sinuses.

Neglected sinus infections or subacute disease leads to chronic irreversible changes in the sinus mucosa. With chronic purulent drainage or sinus blockage, one usually has to resort to surgery after conservative treatment fails. For the maxillary sinus, a Caldwell-Luc antrostomy or an intranasal antrostomy (antral window) is most often used. Removal of the ethmoid cells is most difficult and is done with an intranasal approach when polyps and persistent disease are present. Chronic sphenoid disease is not only rare, but most difficult to diagnose, because X-rays may be inconclusive and symptoms extremely variable. Chronic disease in the frontal sinus, be it osteomyelitis or mucocele formation, dictates a major surgical procedure through either a bicoronal incision flap approach or the osteoplastic eyebrow incision approach, with complete removal of the sinus mucosa and obliteration of the sinus, usually with fat. These surgical procedures and treatment may not result in relief of nasal symptoms or remove the tendency toward recurrent infection. A frontal sinus obliteration is usually disqualifying for most types of aviation.

Antral cysts, which are frequently seen on the Waters X-ray as a smooth, rounded density in the lower aspect of the maxillary sinus, are benign, filled only with clear or xanthochromic fluid. They usually require no treatment, unless they fill the sinus, obstruct drainage, and lead to local symptoms of disease.

Maxillary Sinus Irrigation-Inferior Meatus Puncture

Anesthesia.

1. Spray mucosa initially with a vasoconstrictor.
2. For local anesthesia use four or five percent topical cocaine or 20 percent Benzocaine and two percent Xylocaine with Epinephrine 1:100,000 (dental carpule or equivalent).
3. Apply pledgets of cotton moistened with cocaine or Benzocaine (never sloppy wet) in the inferior meatus and on the inferior turbinate. After initial application, anesthetic on a wire applicator is placed against the lateral wall of the inferior meatus about one inch or 1.5 to 2.5 cm behind the anterior edge of the meatus for five minutes.
4. Insert a long (3 1/2 inch) needle into the inferior meatus until it strikes bone in the area of the intended puncture and infiltrate with local anesthetic.

Equipment.

1. Straight three and a half inch, 18 gauge spinal needle or equivalent trocar with stylet.

U.S. Naval Flight Surgeon's Manual

2. Sterile saline to which a small amount of Neo- Synephrine may be added.
3. One 30 to 50 cc syringe and one 5 cc syringe.
4. Plastic or rubber extension tubing.
5. Culture tube.

Technique.

1. With the patient in a supine position and the head against a firm headrest, the puncture needle or trocar is inserted into the inferior meatus about two centimeters posterior to the edge of the inferior meatus and engaged in the thin bone of the lateral wall of this area.
2. The thumb is placed against the stylet and the needle is directed laterally in line with the outer canthus of the eye, using the fingers of the opposite hand to steady the needle. Pressure is slowly, but steadily, increased until the needle is felt to penetrate into the sinus.
3. The needle is pushed into the sinus until it strikes the lateral sinus wall and then withdrawn about one centimeter. If a low-lying cyst is present, the needle is directed as far inferior as possible just after penetration to puncture the cyst.
4. Direct observation of the drainage or aspiration with a small syringe may be diagnostic or produce a pure specimen for culture. Then place the patient in an upright position.
5. The large syringe and extension tubing filled with normal saline are inserted into the needle and aspiration is attempted. Air bubble or exudate indicates the needle is in the proper position. No aspiration may mean the needle is in the mucosa, plugged, or not in the sinus proper.
6. Irrigation is carried out with the patient leaning forward over a large basin with his mouth open, and gentle, but steady, pressure is applied to the syringe.
7. Instant, severe pain suggests the needle is in the mucosa; readjust the needle's position and repeat. Intolerance to irrigation pressure dictates termination of the procedure and possible attempt at natural ostia irrigation. A slow buildup of pressure and occasionally pain is expected with an obstructed ostia, but it is usually tolerable or relieved as the sinus is irrigated.

Otorhinolaryngology

8. Irrigation should be carried out until the washing is clear or, in the case of a clear irrigation, until at least three full syringes have been used.
9. The final irrigation should be made with the sinus ostia dependent. Insufflation of air into the sinus has been associated with air embolism and should not be performed.
10. The needle is withdrawn with a smooth rapid movement and the nasal passage immediately inspected for retained pus or thick mucus. This material is aspirated, being sure to include aspiration of the posterior floor and middle meatus.

Maxillary Sinus Irrigation - Natural Sinus Ostia - not recommended

Anesthesia.

1. Use Xylocaine 4 percent or Benzocaine 20 percent for local anesthesia.
2. Vasoconstrict the mucosa.
3. Apply anesthetic-moistened pledgets in and around the middle meatus. A long applicator containing anesthetic may also be inserted posteriorly against the area of the sphenopalatine nerve exit.

Equipment. A maxillary sinus cannula plus the equipment used for the puncture technique are required.

Technique.

1. A maxillary sinus cannula is inserted posteriorly into the middle meatus and slowly brought forward with the tip probing for the ostia in the hiatus semilunaris. When the cannula passes into the ostia, it should be anchored with tape to the nose or held in place by the physician.
2. Aspiration and irrigation are carried out in the same manner as for the needle irrigation.

Ethmoid Sinus Irrigation

The Proetz displacement technique can be used for irrigation of the frontal, sphenoid, and maxillary sinus as well as for the ethmoid sinus in nonacute disease.

Equipment.

1. A controlled vacuum source.
2. Sterile 100 cc solution container.
3. Proetz vacuum apparatus (curved olive tip glass collection bottle).
4. Sterile bulb or other syringe, 20 cc or larger.
5. Sterile normal saline into which may be added Neo-Synephrine, not to exceed a total of 1/8 percent.

Technique.

1. Place the patient supine, with head lowered over the edge of the table.
2. Instruct the patient to breathe only through the mouth and not to swallow or talk until instructed .
3. Pill the nose and nasopharynx with the solution through one nostril.
4. Insert the soft rubber or steel olive tip of the vacuum apparatus into one nostril, with no more than 180 mm Hg of vacuum.
5. Close the opposite nostril and have the patient say K-K-K-K-K-K-K-K.
6. Repeat the procedure several times in each side, or until purulent material is no longer present.
7. Stop immediately if the patient has severe pain, or if blood is noted in the irrigation fluid.
8. Give the patient a rest and allow him to sit up to drain out the nose several times during the procedure.

Nasal Fractures

Nasal fractures are common injuries which can usually be handled in the clinic or sickbay by the flight surgeon. There are basically three types: (1) a simple fracture of the nasal bones, most

Otorhinolaryngology

often just the tip, (2) lateral displacement of the nasal bones to one side, often as a green stick fracture on one side and impaction on the other, and (3) marked flattening of the nasal bridge with comminution of the bones or an accordion fracture displacement of the septum. Diagnosis of a displaced fracture can best be made by inspection, palpation, lateral X-ray of the nasal bones and comparison of the patient to his or her ID card or recent photo.

Shortly after injury, when the airway is compromised, or before profuse swelling has occurred, reduction should be accomplished under local or general anesthesia. When the injury is very recent and the patient is still in a shock or “numb” like state, simple lateral displaced fractures can often be reduced without anesthesia by simple, quick, firm, thumb pressure on the convex side of the nose. When soft tissue swelling is marked, distorting the true alignment of the nasal bones, one may elect to wait four or five days for the swelling to recede before reduction. A compound fracture should be reduced within a few hours and then have a plastic-type laceration closure since reduction maneuvers usually tear out delicate sutures. Antibiotic coverage is recommended to prevent complications.

Anesthesia Technique for Reduction of Nasal Fractures.

1. Shrink the nasal mucosa with one percent Neo-Syneprine.
2. Use fresh topical four percent Xylocaine, or 20 percent Benzocaine..
3. Moisten long, thin, cotton pledgets with the anesthetic, squeeze out the excess, and insert them into the superior and middle aspects of the nasal passages. They should touch the septum and turbinate mucosa beneath the nasal bones where reduction instruments are inserted. The sphenopalatine and long nasopalatine nerves may be blocked by applying anesthetic on a long applicator to the area of the sphenoid rostrum. The area can be reached by inserting the applicator back past the posterior tip of the middle turbinate. The ethmoid nerves may be blocked by applying anesthetic on an applicator inserted superiorly just exterior to the middle turbinate tip.
4. Local anesthesia, using two percent Xylocaine with epinephrine (dental syringe carpule), is obtained by inserting a long dental needle into the nasal vestibule just above the upper lateral cartilage at the limen nasi. The needle is slid beneath the skin in the subcutaneous tissue but external to the nasal bones to the desired location.
5. Infiltration sites are the glabella for the superior trochlear nerve, the inner canthus region for the ethmoid and the infratrochlear nerves. A more lateral reinsertion of the needle to

the infraorbital notch will block the infraorbital nerve. Following an initial wheal, the needle is slowly withdrawn while injecting a tract of anesthesia. Repeat on each side. A sublabial approach is also satisfactory.

6. Local anesthesia of the superior septum is obtained by injection of the septum just beneath the tip of the nasal bones and obtaining a "run" of the anesthesia beneath the mucoperichondrium. For the entire septum several anterior injections are required with the bevel toward the cartilage.

Equipment for Nasal Fracture Reduction.

1. Elevator - Most often used is the Sayer elevator. Others are flat scalpel handles or the Salinger reduction instrument.
2. Bayonet forceps.
3. Gelfoam pledgets.
4. Half-inch Vaseline-impregnated gauze, minimum of two tubes.
5. Antibiotic ointment.
6. Rubber finger cot. (optional)
7. Quarter-inch regular or plastic tape.
8. Malleable metal nasal splint.

Nasal Fracture Reduction Techniques.

1. *Septal Fractures Only.*
 - a. Grasp the septum between two fingers, pull forward up, and side to side, using a thumb or finger of the opposite hand to unbuckle a concavity.
 - b. The nose is then packed (beware of toxic shock syndrome) on both sides to maintain a good alignment alone or against a stint.

Otorhinolaryngology

- c. Stints of dental wax or Teflon sheets can be used and held in position with through and through septal sutures.

2. *Depressed Nasal Tip.*

- a. Place a finger cot over the elevator and insert it in either nostril to just beneath the fracture. Using the fingers of the opposite hand to move and guide the fragment, lift the fragment with the elevator and slowly withdraw.
- b. Place compressed Gelfoam beneath the fracture site on both sides. Salvage gauze anterior packing, external taping, and a metal splint offer the best results. Packing should be removed in 24 hours.

3. *Lateral Displaced or Comminuted Fracture.*

- a. Measure the distance externally from the nostril to the glabella on the elevator. Insert the elevator the measured length into the most open side of the nose.
- b. With a steady lift of the elevator, move the fracture further to the deviated side. Then move the nasal bones across the midline an equal distance to the opposite side; return the fragments to the midline. Some bleeding is expected, but in the majority of cases, Gelfoam is all that is required for control, and it helps prevent adhesions that may occur superiorly. External taping and metal protection aid in maintaining alignment.

Taping and Splinting Techniques.

1. Apply benzoin solution to the forehead, nose, and cheek areas.
2. If the nose is packed, the initial tape should run from one side to the other parallel with the dorsum across the packed nares. Do not pull tight, and allow for tissue swelling by cutting or pinching the tape at the tip.
3. Fixation of the nose is provided by an initial tape across the dorsum from cheek to cheek, then a crisscross taping from the forehead to the cheek on both sides. This may be weaved in with the dorsal tapes. If the nose is packed, be sure all of the tip is covered with tape to prevent swelling.

4. A malleable aluminum splint is placed over the nasal taping and held in place by similar crisscross taping.
5. For drainage, a folded two by two-inch pad taped across the lower lip allows the patient to breathe and eat without interference.

Errors in Nasal Fracture Treatment. According to DeWeese and Saunders, the following common errors are associated with treatment of nasal fractures:

1. The doctor attempts to set a nose that was also fractured years previously, but the patient becomes aware of the old deformity only when the new trauma calls attention to it. (Check the patients ID card).
2. X-rays reveal no fracture when one is present altering the doctor's clinical judgment. In reality, X-rays are of little practical value in management of nasal fractures. However, they are of great value in management of fractures of the zygoma and infraorbital sinus.
3. The doctor regards easy to reduce fractures too seriously, and severe fractures too lightly, leading to unnecessary anesthesia or poor reduction because of limited anesthesia.
4. The doctor waits longer than five or six days to reduce; thereafter, reduction may be difficult .
5. In addition, attempting to reduce a fracture in a grossly swollen nose may lead to insufficient reduction or poor alignment.

Maxillary Fractures

Maxillary fractures should always be suspected in direct trauma to the face when there is malocclusion or restriction of mandibular movement, flattening of the side of the face, a "black eye" which included ecchymosis and subconjunctival hemorrhage, anesthesia over the face supplied by the infraorbital nerve, or the more serious sign of diplopia. X-rays are extremely important in diagnosis, as well as postreduction evaluation. A full series should include the Waters, Caldwell, lateral, and submental vertex.

Zygomatic arch fractures can be elevated under local anesthesia through a temporalis fascia approach or a buccal mucosa approach. All other fractures require more extensive open reduction, often with wire fixation or prosthetic support and protection requiring the assistance and training

of an oral surgeon, otolaryngologist, or in the case of a true “blow out” fracture, an ophthalmologist.

Examination of the Mouth and Pharynx

This part of the ENT examination should be thorough and easy on the patient, but it is often most difficult and stressing, both for the physician and the patient. The following points and techniques are recommended. The patient should always be as comfortable as possible and in an upright position. Explanation and instructions to the patient before the procedure is started are absolutely necessary. The physician should reassure the patient and refrain from using uncomfortable words, such as gag, and from putting the mirror down the throat, or pulling the tongue. The patient should be encouraged to relax his tongue during the oral and pharyngeal examination and to breath through his mouth. If there is concern about disease transmission, the physician can wear a mask.

The correct technique for using a tongue depressor is to insert the blade into the mouth without touching the tongue and then to press straight down on the anterior two-thirds of the tongue. Except for hypopharyngoscopy, the patient should not stick out his tongue because this raises and firms up the tongue, preventing good exposure of the tonsils and pharyngeal area. When warming a mirror, the physician should always test the back side of the mirror for proper warmth against his wrist or face so that the patient will not fear being burned. On introduction of the nasopharyngeal mirror, sizes zero, one, or two, it is helpful to slide the handle along the corner of the mouth and touch the patient's face with the finger to steady the mirror. This also helps distract the patient's thoughts about gagging. The nasopharyngeal mirror may be slipped into the nasopharynx alongside of the uvula and may even touch the tip, but touching the base of the tongue should be avoided. When holding the tongue for the laryngeal examination, the under surface should be wrapped with cotton gauze to protect it from the sharp edges of the teeth. The fingers can be steadied against the lower teeth and upper lip. If the patient sits up straight and brings his head and chin forward, the larynx is more fully visible. Fingers against the patient's face steady the mirror (size 3, 4 or 5) as it is introduced into the mouth, without touching the tongue, toward the uvula and soft palate. Often the vocal cords can be seen without touching the soft palate, but if necessary, contact should be positive and firm, with little or no movement after contact is made.

If a patient is unable to breathe through his mouth when requested, it may be necessary to have him hold his nose closed. These examinations should last only 10 to 15 seconds because of salivation, anxiety, and discomfort. For patients with hyperactive gag reflexes, mild mucosal anesthetics such as Chloraseptic or Benadryl Elixir can be tried first. Stronger anesthetic agents

such as Cetacaine, one percent Tetracaine, four percent Xylocaine, or five percent cocaine may be necessary, but some are toxic and rapidly absorbed from the oral mucosa, so care must be exercised in the amount and rapidity with which they are applied. For extremely difficult cases, I.V. diazepam (Valium) of 2.5 to 5 mgm over a 90 second period of administration, gives an excellent effect for 15 to 20 minutes. Since apnea, caine reactions, or cardiac arrest are always a definite danger with these drugs, resuscitative equipment should be at hand.

Common Oral Diseases

Thrush. Since the advent of antibiotics, thrush, formerly seen chiefly in children, is now being seen in adults when the normal flora is altered. The usually white mucosal lesions are scraped for microscopic diagnosis of the characteristic yeast cells.

Treatment of choice is usually with Mycostatin suspension, 1 cc (10,000 units). It is swished around in the mouth for a full five minutes daily, for seven or more days. All other antibiotics are stopped. A one percent Gentian Violet solution may also be applied b.i.d. to the lesions, but the messy staining properties of this solution have decreased its use.

Herpetic Lesions. Fever blisters and cold sores caused by the herpes simplex virus begin with a vesicle that, unlike the aphthous ulcer, usually involves the gingiva; the vesicle breaks and forms an irregular ulcer. These lesions are most common after a febrile illness, trauma, actinic exposure, or stress.

Treatment is symptomatic with nonirritating mouthwashes and oral irrigations; mild anesthetic ointments and solutions may be helpful. Benzoin and Orabase may protect or dry the vesicles and ulcers. Early application of Stoxil ointment or ether has been used, but the success rate is variable, and there is some suspicion of RNA alteration to a carcinogenic state. Corticosteroids are contraindicated.

Aphthous Stomatitis. Recurrent canker sores are found most often as multiple, well-delineated shallow ulcers on the buccal and labial mucosa, tongue, soft palate (including tonsillar pillars), and pharynx; occasionally, there is only a single lesion. These yellow-gray, membrane-covered ulcers heal spontaneously in one to two weeks. There may be severe pain requiring topical and oral anesthetics for eating. Longer relief can often be obtained by cleaning the lesion off and applying Kenalog in Orabase, while it is still dry. This may be repeated three or four times daily. Some physicians advocate the use of Tetracycline suspension, 250 mgm/per tsp., held in the mouth for at least two minutes and then swallowed, four times daily. Aphthous stomatitis should be differentiated from the herpetic gingival stomatitis by lack of bleb or vesicle formation or associated systemic disease, before cortisone treatment is started.

Pharyngitis Sicca or Chronic Dry Throat. The pharynx is usually dry, smooth, and shiny, with some yellow-green crusts. Treatment usually provides only temporary relief, but 50 percent potassium iodide, 10 gtt. in mild t.i.d., SSKI, 6 gtt, in half a glass of water t.i.d., or painting the throat with Mandel's solution may be helpful. Occasionally, three to five grams of ammonium chloride t.i.d. also helps, but fluid and electrolyte balance must be watched.

Pharyngeal Infection. It is sometimes difficult to determine if a pathogen is responsible for an infection in the nose or throat, or which pathogen is responsible. Many organisms such as *Streptococcus veridans*, *Neisseria*, anaerobic streptococci, *Staphylococcus albus*, or yeast are always present and termed normal flora. Although a culture, which takes 24 to 48 hours to grow, may be helpful in treatment and should be obtained, it should be remembered that staphylococci can be obtained from 60 to 80 percent of the population, and beta-streptococci are often isolated from patients with a viral infection. Furthermore, pathogens may become established in the host and remain for months without causing disease. This is referred to as a carrier state. In treatment, the physician must make an intelligent "guess" about the etiology of the infection, using the most important clinical picture, a smear from the infected area for pus cells and predominant organisms, and then correlate this information with the bacteriological findings.

Acute Tonsillitis. Acute bacterial tonsillitis or pharyngitis is most often caused by beta-hemolytic streptococci, Group A. It usually has a rather abrupt onset, with fever of 101° F+ and chills. The mucosa is grossly inflamed, with white or yellow exudate on the lymphoid follicles. If the exudative tonsillar tissue becomes necrotic, it is termed necrotizing tonsillitis.

The antibiotic treatment of choice is penicillin, most often given orally, 250 mgm, q.i.d. An initial I.M. dose of 1.2 to 1.5 million units of procaine penicillin may be given to adults, to obtain a more rapid blood level. Therapy should be continued ten days.

With toxic symptoms, the patient should be on bed rest and forced fluids. Hot throat irrigations hourly or at least four times daily, coupled with analgesics, such as Empirin Compound #3, Ascodeen - 30, or Tylenol #3, are necessary for both comfort and a more rapid recovery.

Infection of the lingual tonsils at the base of the tongue, often not properly diagnosed without the aid of the laryngeal mirror, may cause considerable dysphagia. Besides the normal treatment for tonsillitis, the physician may need to add, by direct application, gargle or spray, soothing substances such as Chloraseptic solution, Mandel's paint, or a topical anesthetic, such as Dyclone, 0.5 percent or 1 percent.

Nasopharyngitis. Occasionally, a physician may see a patient who appears toxic and febrile, with pressure or pain in the ears, a severe headache, or retrobulbar pain. Usually, the oropharynx

is somewhat inflamed, and there is occasionally neck stiffness or edema of the uvula. Examination of the nasopharynx with a mirror will make the diagnosis of nasopharyngitis with the discovery of exudate in upper reaches of the nasopharynx. Treatment with I.M/I.V. antibiotics initially, plus supportive treatment, is advocated.

Viral Pharyngitis. Sore throat, lymphoid injection without exudate, general or posterior cervical adenopathy, and malaise are the usual symptoms of a viral pharyngitis; a normal white blood count with increase in the lymphocytes is often the blood picture. Tonsillitis that has a membranous exudate, marked lymphoid hypertrophy, often a negative throat culture, and does not respond to penicillin, should be evaluated for infectious mononucleosis. Diagnostic tests include white blood count, differential, and a mononucleosis spot test.

In areas of frequent cases of gonorrhoea, resistant or unusual cases of pharyngitis should be cultured, specifically for *Neisseria gonococci*.

Thornwaldt's Disease. Physicians should be aware of a nasopharyngeal bursa or pouch that sometimes forms in the midline of the adenoid tissue and, when it becomes infected, produces occipital headaches and an irritating, purulent postnasal discharge; it can also be present after adenoidectomy. Diagnosis is made by ruling out sinus disease and visualization of the draining bursa with the nasopharyngeal mirror, or more clearly, the nasopharyngoscope, or Yankhauer scope. Treatment requires either electrocoagulation or surgical removal of the cyst or pouch.

Peritonsillar Abscess. Known also as quinsy (sore throat), this abscess results when tonsillar infection spreads or breaks through posteriorly into the potential areolar space between the tonsil and the superior constrictor of the pharynx. Formation of the abscess results in displacement of the tonsil toward the midline, anteriorly and downward, with displacement of the uvula to the opposite side; it also causes fullness or cellulitis of the soft palate. There is a variable degree of trismus, pain referred to the neck or ear, variable adenopathy, and often the classic "potato" speech that results from the spasm or cellulitis involving the pharyngeal muscularity.

Treatment consists of high doses of systemic antibiotics for 10 to 14 days and incision and drainage (I & D) of the abscess immediately, if fluctuant, or as soon as fluctuance develops. If spontaneous drainage is noted from a necrotic site, gentle suction and blunt, careful widening of the opening assists in providing adequate drainage. Hot saline throat irrigations every few hours and adequate analgesics are necessary for the first few days. The I & D site should be reopened in 24 hours. Occasionally, a second or third reopening may be necessary if considerable pus continues to accumulate. Emergency tonsillectomies are performed by some physicians as a treatment for the abscess, but this should only be done by experienced hands because of the danger of

Otorhinolaryngology

bleeding or sepsis. It is advised that an elective tonsillectomy be considered in about six weeks, after the acute infection has subsided.

Incision and Drainage of Peritonsillar Abscesses.

1. Equipment

- a. Long handle, curved Kelly forceps with smooth blunt tips.
- b. Suction machine with tonsil and/or nasal suction tips.
- c. Long knife handle with #15 blade.
- d. Large metal basin.
- e. Culture tube.

2. Anesthesia

- a. Premedication with I.M. Demerol/Vistaril or I.V. Valium is recommended.
- b. Topical Cetacaine, or four percent Xylocaine is helpful.
- c. Local infiltration at the incision site with dental two percent Xylocaine and epinephrine, 1:100,000, is often used, but some physicians are against infiltration into cellulitic tissue.

3. Procedure

- a. The best site for *incision* is at the point of intersection of a vertical line from the last molar tooth on the involved side and a horizontal line from the lower edge of the soft palate on the opposite, uninvolved side. The incision should be made from lateral toward the midline, about 1.5 to 2 cm long, just through the mucosa.
- b. The curved Kelly is introduced into the incision and spread, opening over the top, but never through, the tonsil. The tip is at first directed straight in, then slightly downward and medially.

- c. When the abscess cavity is opened, there is a sudden, often forceful, release of thick pus, for which both the physician and the patient should be prepared.
- d. With the patient leaning slightly forward, immediate, rapid, but gentle, suction is applied to the draining pus and incision site.
- e. The incision must be opened sufficiently. Bleeding is usually slight and clots form in five or ten minutes. A sterile nasal suction tip may be inserted into the incision site for better evacuation of the pus, but strong suction should not be applied, as this may create severe bleeding.
- f. Hot saline irrigations, three or four times per day, are recommended. One or two liters of saline are used for each irrigation. The solution can be used directly from a commercial container or mixed by the pharmacy. Murphy drip bottles, irrigation cans, or the solution bottles connected to I.V. tubing are placed eight to ten feet high. A small oral irrigation tip or glass or plastic eyedropper can be used to deliver a forceful, narrow stream. The solution should be as hot as tolerable without burning the oral tissue.
- g. An acceptable alternative to incision and drainage (I & D) is aspiration of the abscess by an 18 gauge needle attached to a 10 cc syringe.

Laryngology

There are four major functions of the larynx - airway, sphincter, protection, and phonation.

As an airway, the vocal cords are constantly regulating the required air flow needed by the lungs and maintaining a proper resistance or back pressure.

When we strain or lift with our arms and chest muscles, the vocal cords close, trapping air in the chest cavity, fixing the chest wall, and allowing for maximum efficiency in the lift. This function comes into play for the cough and for the effort in defecation.

The larynx is said to be the "Watch Dog of the Lungs". Through the sensory branches of the superior laryngeal nerve, foreign bodies, abnormal mucus, pus, or fluids are prevented from entering the trachea by the rapid closure of the cords, followed by coughing or by clearing of the throat.

The vocal cords produce sound which is modified by the lips, teeth, tongue, and palate to form speech or singing tones.

Diseases of the Larynx

Hoarseness. Hoarseness is defined as roughness or discordance in the quality of the voice. It is apparent that it is a symptom and not a disease process in itself. Often, the first and only danger signal of serious disease, local or systemic, involves this area. Unfortunately, the degree of hoarseness presents no clue to the type of illness or its prognosis. A thorough examination is necessary in all cases to ascertain the exact cause and to prescribe the proper treatment. Generally, there are intrinsic lesions such as inflammation, benign or malignant neoplasms, allergies, and trauma. There may be disturbances in innervation, either central or peripheral. Hoarseness may be a manifestation of system disease, such as TB, syphilis, muscular dystrophy, arthritis, or endocrine disorders, and finally, psychosomatic involvements must be considered when all else has been eliminated. No more than two weeks should pass before an examination is made of the vocal cords.

Acute Laryngitis. The chief symptoms of acute laryngitis are pain and hoarseness, and they may be secondary to an upper respiratory infection, most often viral, or hemophilus in children or streptococcus in adults. On laryngeal examination, the vocal cords and adjacent subglottic and arytenoid area are inflamed, and there may be various degrees of swelling.

In most cases, treatment of the primary illness with appropriate antibiotics, cough suppressants, steam inhalation, elimination of irritants, especially tobacco and alcohol, and voice rest, is sufficient. Lozenges such as Cepacol, anesthetics, troche with benzocaine, or throat sprays such as Larylzan, may be soothing. Laryngitis from vocal trauma and noxious gases is best treated with voice rest and humidification. Thermal burns or caustic injury may require, in addition to other treatments, system steroids and tracheotomy.

Chronic Laryngitis. Chronic laryngitis includes many different conditions and implies longstanding inflammatory changes in the mucosa, as might be expected from recurrent acute episodes, chronic improper use of voice (singers, speakers, and hucksters), and exposures to adverse conditions, such as dust and fumes. Smoking and alcohol have been shown to contribute, as well as TB, syphilis, and chronic sinusitis or bronchitis. Chronic laryngitis may take the form of small, bilateral vocal nodules or large polyps at the junction of the anterior and middle third of the vocal cords. Other forms are hypertrophic or hemorrhagic changes on the cord or dry thickening of the interarytenoid area. Vocal activities must be limited and rest encouraged. Surgical measures will occasionally become necessary. The flight surgeon should encourage the patient to keep well

hydrated. Expectorant drugs, such as potassium iodide or guaifenesin chloride are advocated, as is the use of humidification. The flight surgeon should follow the patient closely by regular mirror laryngoscopy to assure early treatment should surgical pathology develop.

Salivary Glands

Calculi occur more frequently in the submaxillary duct and gland. A common sign may be painful swelling of the glands when the patient eats. Localization of the calculus can often be made by bimanual palpation of the gland or duct, along the floor of the mouth, and a dental X-ray of the floor of the mouth. If the calculus is in the duct, it can often be milked toward the papilla. Removal is facilitated, after local infiltration with Xylocaine, by cutting off the papilla to enlarge the orifice and then slitting along Wharton's duct. Calculi in the proximal duct or gland may require excision of the gland if the obstruction cannot be relieved. Infection behind the obstruction usually responds to drainage but may require antibiotics as in sialadenitis.

Acute Sialadenitis. The parotid is more often affected than the submaxillary gland, usually resulting from retrograde extension of the mouth infection and dehydration, especially in the elderly. The duct should be milked and a culture taken; however, the most common organism is often a penicillin-resistant, coagulase-positive staphylococcus. The empirical choice of antibiotics would be adequate doses of cephalothin or methicillin. Correction of the dehydration is essential, and X-ray of 400 to 600R may be helpful in the treatment of pain and swelling. In severe resistant cases, I & D of the gland may be lifesaving.

Chronic Sialectasis. Recurrent infections or, occasionally, congenital anomalies lead to stasis of secretions and chronic dilation of the ducts and alveoli, which can be diagnosed by sialography. Long-term therapy with tetracycline is often helpful, but unresolved symptoms may necessitate excision of the affected gland.

Auriculotemporal Syndrome. After parotidectomy or injury to the gland, the patient may experience gustatory sweating, called Frey's Syndrome. Temporary relief might be obtained by Scopolamine, but more lasting results may require a tympanic neurectomy of Jacobson's nerve and the chorda tympani nerve. Treatment with an antiperspirant may suffice.

SECTION II:

AUDIOLOGY

The Physics of Sound

Sound is a remarkable phenomenon. It enables us to communicate with each other, to learn new ideas, to influence others, and to enjoy life. It is intrinsically involved in human activity. Without it, we would withdraw socially; too much of it, and our sense of hearing would be dulled.

The science of sound, acoustics, provides a basis for understanding hearing and communications. Sound can be described as a wave-like pressure fluctuation in air that conveys energy from the source outward in all directions. Sound can also be transmitted by fluid or solid media, but for simplicity, this discussion will consider only the air medium. Sound is also that which is perceived by people or the human brain, so it will be necessary to describe the dual nature of sound in terms of its physical and physiological characteristics (Table 8-7).

Table 8-7

Parameters of Sound

Physical	Psychological	Approximate Human Range
Frequency (Hertz)	Pitch (Mel)	20-20,000 Hz
Intensity (Decibel)	Loudness (Sone or Phon)	0-120 dB
Spectrum	Quality	∞

The basic physical characteristics of sound are its frequency, intensity, and spectrum. Frequency, measured in hertz (Hz) or cycles per second (cps) is the number of positive or negative pressure fluctuations of a sound wave each second. Frequency largely determines pitch, although it is not quite a one-to-one relationship. The subjective term pitch comes from the musical vocabulary and is the relative lowness or highness of that attribute of sound relating to the frequencies of the musical scale. The gross frequency range of human hearing for young, healthy, and undiseased ears is from below 20 to over 20,000 hertz.

The intensity of a sound is the term generally used to describe the amplitude component of a sound wave. Intensity is not actually measured; sound pressure is usually measured, and its level

is related in decibels (dB) to an arbitrary reference pressure. Thus, the term sound pressure level (SPL) denotes the measured sound pressure and is defined according to the following equation: $SPL = 20 \log P/P_0$ dB, where P represents the measured rms pressure in Pascals (Pa), and P_0 is the reference pressure in Pascals. The decibel is, then, a dimensionless logarithmic unit. The reference pressure used by acousticians is 20 Pa (or 20 N/m²) and will be used throughout this chapter. All sound level meters will be calibrated to this reference pressure. Loudness is loosely related to intensity, depending somewhat upon frequency and spectrum. Much of the literature of psychoacoustics deals with the detailed description of this complex relationship.

The basic curves (Figure 8-2) showing equal loudness versus frequency at different levels were originally developed by Fletcher and Munson in 1933. Sound level meters contain a set of frequency-weighting networks which correspond to different loudness levels. Thus, the A-weighted level, L_A , corresponds to an equal loudness contour near threshold, the B-weighted level, L_B , to a moderate loudness level (55 to 88 dB), and the C-weighted level, L_C , is nearly "flat" or unweighted and corresponds to a loudness sensation above 85 dB.

The useful amplitude range of human hearing is from 0 to 120 dB. The threshold of hearing is the minimum level of sound that evokes a response in at least 50 percent of the trials. Hearing sensitivity is the general term denoting the absolute hearing threshold of an individual. Hearing acuity is the just-noticeable-difference in a controlled change of frequency, intensity, or spectrum. Masking is the process by which the threshold of audibility of one sound is raised by the presence of another (masking) sound.

The type of sound used most widely for hearing testing is a discrete frequency stimulus called a pure tone. Most sounds, however, are complex mixtures of various frequencies and intensities. In order to identify and to classify these complex sounds, a frequency analysis is obtained which, when graphed, results in a spectrum analysis curve.

A sound spectrum may, for example, be composed of most audible frequencies and would be called broad-band or wide-band noise. A sound with a few closely related frequencies would obviously be called narrow band. Noise having all frequencies with equal energy is called white noise, and noise with a gradual decrease in amplitude of the higher frequencies is called pink noise. Musical sounds, when analyzed, produce line spectra since they are composed of fundamental frequencies and overtones or harmonic frequencies which are arithmetically related to the fundamental.

The sensation of complex sounds is rather difficult to describe. We are probably able to distinguish complex sound patterns by repeated exposure, and we store auditory "images" and

patterns of changing spectral and temporal components. The more the repetition, the finer is the ability to make subtle distinctions (e.g., the difference in the sound quality between a Stradivarius and a Guamerius violin).

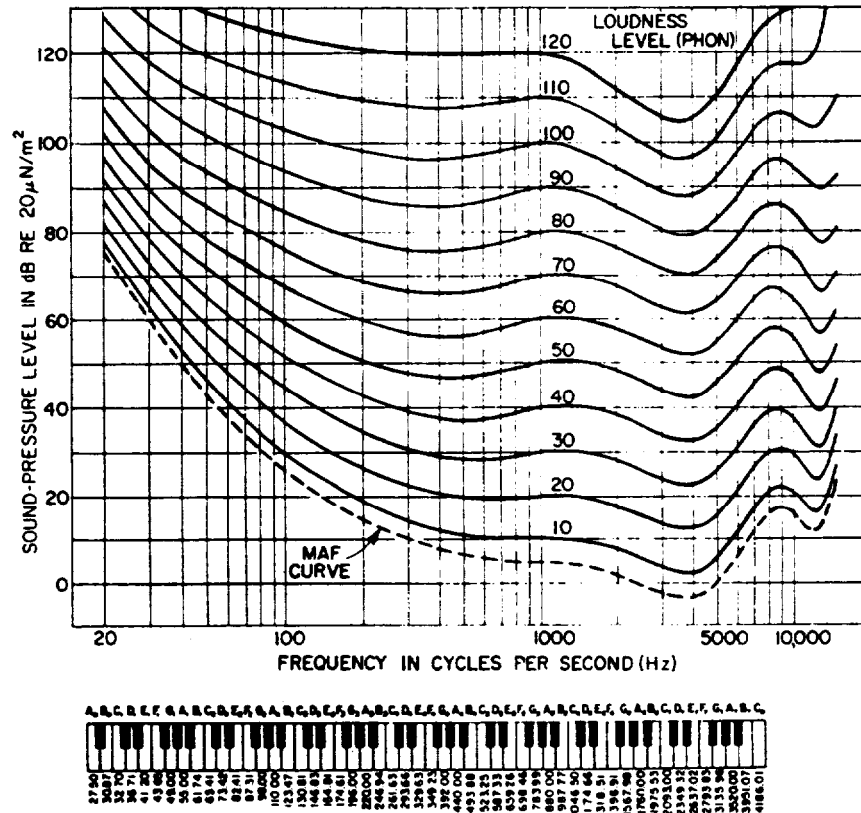

Figure 8-2. Free-field equal-loudness contours for pure tones (observer facing source) determined by Robinson and Dadson. Piano Keyboard helps identify the frequency scale. Only the fundamental frequency of each piano key is indicated (Peterson & Gross, 1972, published by permission of GenRad, Inc.).

The graph in Figure 8-3 is a composite which brings together various levels of hearing and tolerance throughout the audible range of hearing. The sound pressure level scale extends from below 0 dB to over 160 dB SPL and has as its reference 20 Pa. The minimum audible field (MAF) curve is the absolute threshold of hearing versus frequency and is the same as the 0 dB loudness curve in Figure 8-2. This curve is also very nearly 0 dB on the audiometer. Notice that the ear is less sensitive between 3000 and 4000 Hz. Below 18-20 Hz, we feel rather than hear the vibrations

in the infrasonic range. Above 20,000 Hz, we sense a sort of pressure for sound in the ultrasonic range.

The speech area ranges from 80 to 100 Hz to around 10,000 Hz and from about 40 dB to 80 dB SPL. Telephone and aircraft radio systems, however, are designed to transmit mainly the frequency range from 300 to 3000 Hz. At levels around 120 dB SPL, many individuals find that they can no longer tolerate the noise and will try to get away from it or seek hearing protection. Note that this is 30 dB above the lower level for the damage risk criteria (DRC) for the Navy Hearing Conservation Program (Section III) based upon an eight-hour workday. At 130 to 140 dB SPL, many people describe sensations of pain or tickle in their ear canals. A 160 dB SPL, tissue damage has been observed in deaf subjects, viz., a bruising of the capillaries of the tympanic membrane particularly around its periphery and near the manubrium of the malleus.

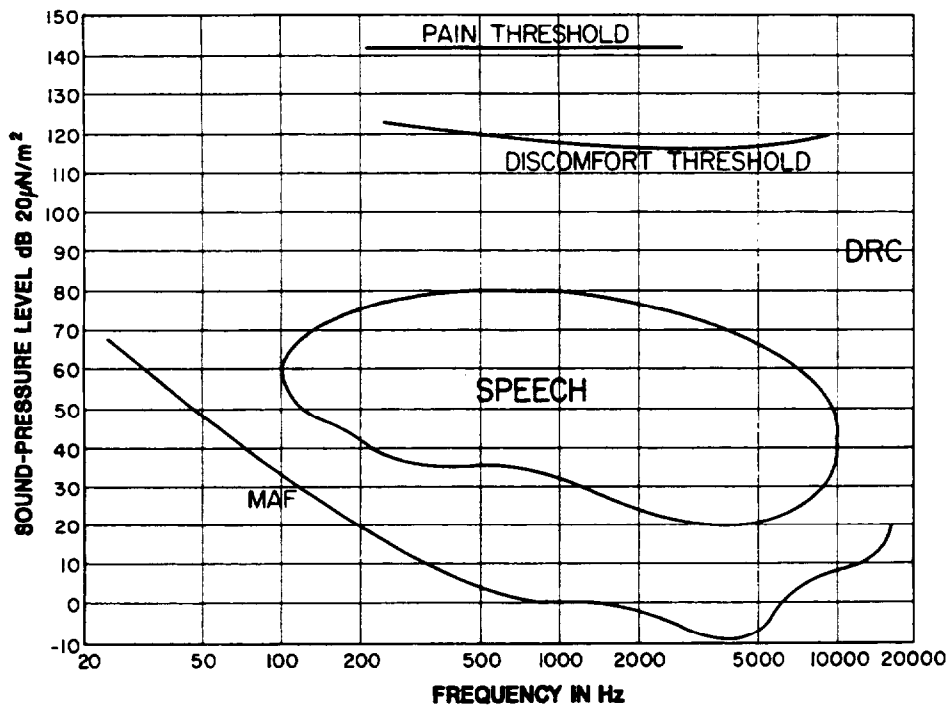

Figure 8-3. Thresholds of hearing and tolerance (adapted from Peterson & Gross, 1972, published by permission of GenRad, Inc.)

Measurement of Hearing

Introduction

An individual having a significant hearing deficit may be identified through a simple audiogram done during a physical examination or as a part of the Hearing Conservation Program (HCP). After this identification, a more detailed clinical evaluation is warranted.

The clinical measurement of hearing and the interpretation of findings resulting from such measurements has become progressively more sophisticated since the end of World War II. A whole new professional field involving measurement, diagnosis, and rehabilitative aspects of hearing impairments has arisen since that time. The field is called audiology.

Civilian audiologists are employed at the Navy's two Aural Rehabilitation Centers at Oakland, California and Portsmouth, Virginia. Military and civilian audiologists are now on the staffs of many naval hospitals serving in Otolaryngology and Occupational Health and Preventive Medicine Departments.

Increasing availability of clinical audiology services in the Navy means that the flight surgeon will see more and more clinical audiology reports in medical records. For this reason, the flight surgeon must understand the basic concepts of hearing measurement and interpretation to take full advantage of the more detailed information contained in the audiologists' reports.

Basically, there are four reasons for obtaining hearing measurements (audiometry): (1) to aid in medical diagnosis of an existing problem, (2) to plan a rehabilitation program, (3) physical evaluation for admission or retention in a particular program or task area, and (4) for hearing conservation purposes. The first area mentioned above is the topic of this discussion.

Background

The term decibel (dB) is routinely used in reporting the results of hearing testing. When used for this purpose, the dB is always referenced to a value called audiometric "zero", which represents statistical averages of hearing threshold levels of young adults with no history of aural pathology. The current standard is ANSI (American National Standards Institute) S3.6-1969. An earlier standard, on which many hearing tests on older personnel might be based, is ASA (American Standards Association) Z24.5-1951. The newer standard was adopted because it more accurately reflects the hearing of people today and is in substantial agreement with the ISO (Inter-

national Organization for Standardization) R389-1964 recommendation. The ASA, ISO, and ANSI average minimum audible pressure curves are shown in Figure 8-4.

Note that the values are plotted in dB Sound Pressure Level by frequency. The numeric values for each data point and the difference between the two standards are shown immediately above the graph. All of the ANSI threshold values are smaller (lower SPL) than their corresponding ASA values. This is a result of better subject selection, better electro-acoustic equipment, and better sound isolating booths for testing.

The term audiometric "zero" is applied to each of these values. For example, the average hearing threshold level (HTL) at 1,000 Hz for the ANSI standard is 7.0 dB SPL; this is audiometric "zero" for that frequency. The same holds true for 6,000 Hz for the ANSI standard, where audiometric "zero" would be equal to 15.5 dB SPL. It is this way of specifying audiometric "zero" that permits the use of a straight line for "zero" on the graphic-type audiogram form (Figure 8-5). All Navy audiometers are now calibrated to the ANSI-1969 standard.

If both ASA and ANSI audiograms appeared in the medical record of an individual whose hearing has not changed, it would seem that hearing has gotten worse. This is due to the different audiometric "zero" standards and not to any organic change in HTLs. To convert the ASA audiometric findings to ANSI, one would add the difference values in Figure 8-4 to produce an audiogram directly comparable to the ANSI findings. The flight surgeon should be alert to this occurrence so that inappropriate referrals are not made.

Another type of report format found in the medical record is the tabular audiogram (Figure 8-6). This is simply the numeric presentation of HTLs by frequency. One also frequently finds a graph-type audiogram card in the medical record produced by self-recording audiometers (Figure 8-7).

These audiograms are very often done as part of the hearing conservation monitoring program. A self-recording card should not be left in the record. The HTLs should be transposed to a serial, tabular form which should be a permanent part of the medical record. This greatly facilitates comparisons of current and previous audiometric results. Most frequently, testing done at naval hospitals would be reported in the graph format (Figure 8-5).

Frequency (Hz)	125	250	500	1000	1500	2000	3000	4000	6000	8000
ASA Z24.5 (1951) 0 dB Hearing Level	51.8	39.5	24.1	17.2	18.0	18.0	15.6	14.3	19.5	26.8
ISO R389 (1964) 0 dB Hearing Level	42.8	24.5	10.1	7.2	8.0	9.5	7.1	8.3	10.0	15.3
ANSI S3.6 (1969) 0 dB Hearing Level	45.0	25.5	11.5	7.0	6.5	9.0	10.0	9.5	15.5	13.0
ASA-ANSI	6.8	14.0	12.6	10.2	11.5	9.0	5.6	4.8	4.0	13.8

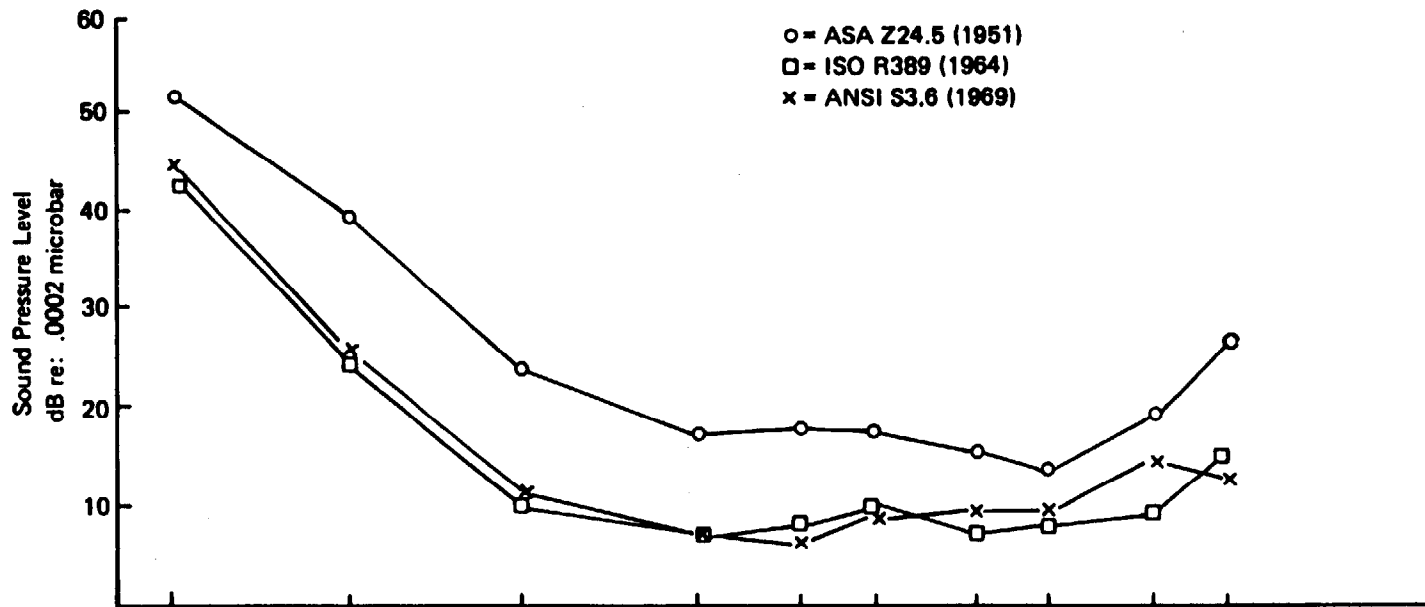

Figure 8-4. Audiometer reference threshold pressures for TDH-39 earphone sound pressures re: .0002 microbar as measured in NBS-9A coupler.

U.S. Naval Flight Surgeon's Manual

NAVHOSP PNCLA 6120/22 (Rev. 1-87)

NAME: _____

HEARING EVALUATION REPORT
Frequency, in Hertz (Hz)

SSAN: _____ DATE: _____

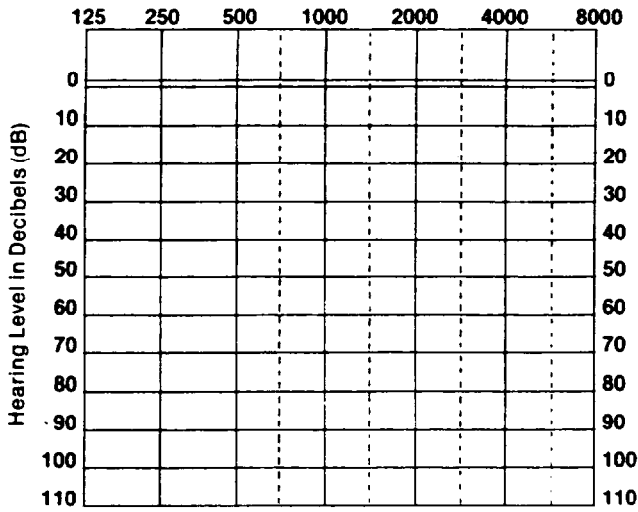

SYMBOL KEY

	Right	Left	Sound Field
AC UNMASKED	○	×	
AC MASKED	△	□	
BC UNMASKED	>	<	
BC MASKED	▷	◁	
NO RESPONSE	↘	↙	
SOUND FIELD			S
AIDED SOUND FIELD			.

DEFINITIONS

CNT: Could not test
DNT: Did not test

Calibrated re: ANSI 1969

RELIABILITY: Good Fair Poor

	Pure Tone Avg.		Speech Tests							
	2 freq.	3 freq.	SRT	PB Max	Level	MCL	UCL	SF	SRT	PB MAX
Right	dB	dB	dB	%				Unaided		%
Left	dB	dB	dB	%				Aided		%

OTHER TESTS:

TYPANOGRAMS-SUMMARY

ET FUNCTION	EAR	TYPE	CONTRA REFLEX	IPSI REFLEX	REFLEX DECAY	METZ	TGRAMS ATTACHED
	RT						
	LT						

AUDIOMETRIC DATA RE: ANSI S3.6	LEFT						RIGHT					
	500	1000	2000	3000	4000	8000	500	1000	2000	3000	4000	8000
CURRENT AUDIOGRAM DATE: year month day												
REFERENCE AUDIOGRAM DATE: year month day												
THRESHOLD SHIFT + = Poorer - = Better												

COMMENTS: _____

Signature: _____

Figure 8-5. Graphic audiogram form.

Otorhinolaryngology

HEARING RECORD
NAMI 6120/3 (REV. 9-68)

																	AGE
AIR CONDUCTION																	
RIGHT									LEFT								
DATE	250	500	1000	2000	3000	4000	6000	8000	250	500	1000	2000	3000	4000	6000	8000	EXAMINER
BONE CONDUCTION																	
RIGHT									LEFT								
DATE	WHITE NOISE	500	1000	2000	3000	4000	OPPOSITE EAR MASK AT		500	1000	2000	3000	4000	LOW TONE	EXAMINER		
WHISPER		CONV		RINNE		SCHNABACK		WEBER		GELLE		CALORIC			EXAMINER		
SPEECH RECEPTION																	
DATE		SPOND.	OTHER	MIC.	REC.	DATE		SPOND.	OTHER	MIC.	REC.						
	RIGHT						RIGHT										
	LEFT						LEFT										
	FREE FIELD						FREE FIELD										
DATE		Pd	AT	%	MIC.	REC.	EXAMINER	DATE		Pd	AT	%	MIC.	REC.	EXAMINER		
	RIGHT								RIGHT								
	LEFT								LEFT								
	FREE FIELD								FREE FIELD								
REMARKS																	

Figure 8-6. Tabular audiogram form.

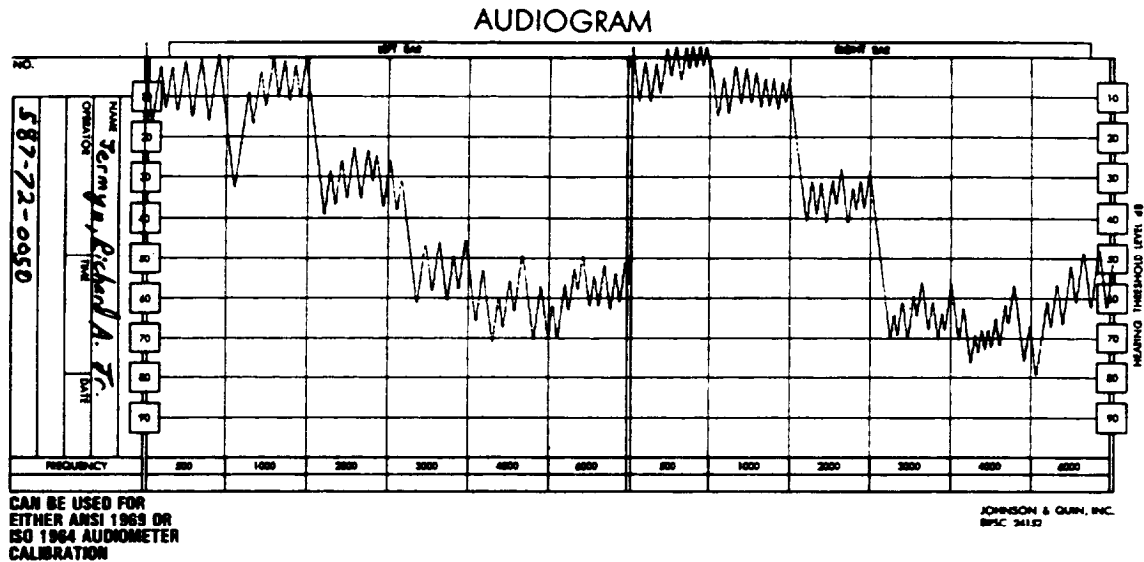

Figure 8-7. Audiogram card produced by self-recording audiometers.

The instrument used for more advanced hearing testing is a clinical or diagnostic audiometer. It very often is a two-channel unit and combines pure tone and speech audiometry in a single cabinet. The two-channel capability permits the presentation of a different stimulus to each ear simultaneously or “mixing” two stimuli for presentation to the same ear, etc. There are many potential combinations. In the latter case above, one may want to “mix” speech and noise to present to one ear. The two stimulus levels (amplitudes) can be controlled independently, so that a positive or negative signal-to-noise (S/N) ratio can be created. This is often done in testing speech discrimination ability. Presenting speech and noise together makes the test much more realistic than presenting speech in quiet. Clinical units also have provisions for microphone, tape, phono, or internal oscillator input for pure tones. These inputs are fed through an attenuator and amplifier and then to the output transducer which would be an earphone or bone conduction vibrator, but it could be one or even two speakers.

Clinical testing is conducted with the patient seated in a sound-treated room with the examiner in an adjacent room. The examiner can operate the equipment, whose output is cabled through the sound room wall, and can observe the patient through a window. The noise level inside an audiometric test booth is critical and is specified in ANSI S3.1, 1977. The subject responds, in the case of pure tone testing, by either pressing a button, which triggers a response light on the audiometer, or simply by raising his hand or finger. For speech audiometry, the subject responds by writing or checking off the word identified or by repeating the word aloud after the examiner. There is provision for two-way communication between the patient and examiner.

Basic Hearing Tests

Pure-Tone Audiometry. The most common and also the most elementary test is done with pure tones. The patient is asked to respond whenever he hears a tone, regardless of the loudness of the signal. The lowest amplitude at which the patient responds at a particular frequency is called the hearing level (HL). HL's are determined at octave frequencies from 250 to 8000 Hz and at the half-octave frequencies of 3000 and 6000 Hz. Each continuous tone is presented for a period not exceeding one second. Intermittent (pulse) tones are also frequently used, especially in patients where tinnitus is present. There will be several tone presentations at a particular frequency before the HL is recorded on the audiogram (Figures 8-5 and 8-6). In general, pure-tone HL's are determined for both air conduction (earphones) and bone conduction (vibrator) stimuli.

Masking noise is used when one ear needs to be isolated from the other in order to get a correct threshold measurement for the test ear. Masking noise is generated within the audiometer and can consist of a broad or narrow-frequency band. Narrow band noise is most efficient for masking pure-tones. In a situation where one ear of the patient is "dead", incorrect information would be obtained for the nonfunctional ear if masking were not used for the good ear. By air conduction measurement, the nonfunctional ear would yield HL's around 50 to 60 dB. This is due to a phenomenon called "crossover". Even though the signal is presented at the nonfunctional ear, it is heard by the good ear primarily by direct energy transmission through the head from the vibrating earphone cushion. The head creates about a 50 to 60 dB "barrier" between ears. If proper masking noise is applied to the good ear in the case mentioned, then a correct determination of a profound hearing loss would be made.

An electromechanical vibrator is placed on the mastoid process for bone conduction (BC) testing. The threshold determination procedure is identical to that of air conduction (AC) testing. Since it requires more energy to drive a mechanical vibrator than an earphone, the maximum hearing loss that can be measured for BC is less than for AC, (e.g., 70 dB for BC and 100 for AC). Care should be taken to place the vibrator on the mastoid without contacting the pinna. This is to ensure that responses at low frequencies are auditory and not tactile in nature. Masking of the contralateral ear is done more frequently in BC than in AC. This is because interaural attenuation, while about 50 to 60 dB for AC, is practically nonexistent (0 to 5 dB) for BC. In the previous example of the "dead" ear, a BC measurement without proper contralateral masking would have shown normal BC hearing in the nonfunctional ear due to the low (0 to 5 dB) crossover levels.

Speech Audiometry. Another aspect of the basic hearing test battery is speech audiometry. The purpose here is to discover two things. First, it is necessary to determine the amplitude at which

the patient can repeat back approximately 50 percent of the two-syllable words presented to him. This measure is referred to as the speech reception threshold (SRT). There are six word lists, each list being a different scrambling of the same 36 words. The most widely used form is CID Auditory Test W-1. Secondly, the percentage of 50 single-syllable words the patient can correctly repeat back is determined. This test is called the "PB score" or "PB Max" and is a measure of speech intelligibility. The term "PB" stands for "phonetically-balanced". When these word lists (24 lists with 50 words each, and 200 words in the corpus) were developed in the late 1940's, it was believed that the phonemes in each 50-word list had to have the same proportionate frequency of occurrence as that in everyday English, in order for the test to be valid. This was later shown to be unnecessary, but the terminology "PB" still remains today.

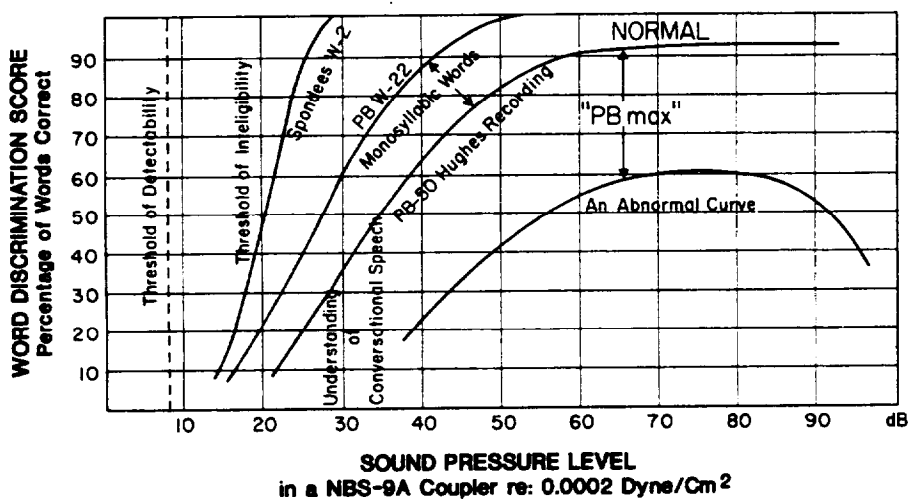

Figure 8-8. These typical word intelligibility curves demonstrate the relationship between word discrimination and amplitude (Davis & Silverman, 1970).

A graph demonstrating the relationship between word discrimination and amplitude (SPL) is shown in Figure 8-8. The various curves shown are called articulation curves or performance intensity (PI) functions. The PB words, the most widely used form being CID Auditory Test W-22, are presented at a level of 40 dB above the SRT in routine use. Since this represents a supra-threshold presentation, masking noise is almost always used in the contralateral ear. It is at this amplitude or sensation level (SL) that most patients would achieve maximum performance. However, there are instances where this is not the case. So, ideally, a performance intensity function would be generated by presenting the monosyllabic word lists at a variety of sensation levels. A phenomenon called roll-over is demonstrated in Figure 18-8 by the abnormal curve. Roll-over

is characterized by a worsening of discrimination as loudness is increased. This finding is characteristic of retrocochlear disorders (e.g., acoustic neuroma) and to a lesser extent Meneire's syndrome.

Often speech discrimination testing is done in a noise background. A variety of word lists and test formats are used for this purpose. The basic concept behind this is to provide a more realistic environment in the measurement of speech discrimination. It is a rare occasion, particularly in the naval environment, when the listening environment is absolutely quiet. There are several considerations for discrimination in noise testing. Probably the most important, single consideration is the signal to noise ratio (S/N) employed in the test. S/N ratio is expressed in dB, and the figure represents the number of dB the signal (speech in this case) is above or below the level of the noise. If the S/N is minus 4 dB, this would mean that the average speech level is 4 dB below the noise level. Typical S/N levels used in discrimination testing that would be reflective of typical naval aviation noise environments would range from 0 to +4 dB S/N.

Threshold Tone Decay Tests. Another component of the basic test battery is the threshold tone-decay test (TDT). This is a pure-tone, supra-threshold test. It is usually done at 4,000 Hz first, and, if positive, the test frequency is dropped by octaves until 500 Hz is tested. The tone is presented at 5 dB SL for one minute. If the patient can hear the tone for the entire period at the same level, the test is negative. If the level of the tone has to be raised by 20 or more dB above the starting level, the test is positive. The TDT is a measure of auditory adaptation and is considered a screening test for retrocochlear pathology. If the test is positive, other, more detailed, tests would be done in order to help establish the reason for the abnormal adaptation and the site of the lesion. The Suprathreshold Adaptation Test (STAT) is also frequently used. The test is positive if a high level (e.g., 100 dB) tone cannot be heard over a 60 second period.

Advanced Tests in Differential Diagnosis

Short Increment Sensitivity Index (SISI). This is a pure-tone test presented at 25 dB SL that measures amplitude discrimination ability. The result is expressed in terms of percent correct identification out of twenty, one-Db increments, added to a reference pure-tone level. A high percent correct response is indicative of a cochlear pathology.

Alternate Binaural Loudness Balance Test (ABLB). This is one of two direct tests of a phenomenon called recruitment. Recruitment is an abnormal growth of loudness in which soft sounds are not heard while loud sounds are perceived to be as loud as in a normal ear. The presence of recruitment narrows the dynamic range of hearing significantly and is characteristic of a cochlear (sensory) pathology. In order to do this test, it is necessary for hearing to be within

normal limits in the contralateral ear at the same frequency at which the test is being done in the poorer ear.

Bekesy Audiometry. Bekesy audiometry is an advanced site-of-lesion test and is a special form of the more routine, self-recording audiometry procedure. The patient is asked to track his pure-tone threshold by means of a response button, first for a pulsing tone and then for a continuous tone. Either a discrete frequency or continuous frequency tracing can be generated. The audiograms are traced on the same graph. The audiogram is then categorized according to the relationship between the pulsed and continuous tracings. There are five recognized types of Bekesy audiograms. Each type is supportive of a particular pathology and will be discussed in the section on interpretation of findings.

Auditory Brainstem Response (ABR) Audiometry. ABR audiometry and electrocochleography (EChocG) are two relatively new objective hearing tests. Both are electrophysiological measures of auditory function. These are noninvasive techniques that involve computer averaging of the auditory system's electrical response to clicks or tone pips. Either of these tests could be used in cases of functional (nonorganic) hearing loss or psychogenic problems. The ABR is particularly useful in cases of suspected brainstem lesions. The flight surgeon should have little contact with these test types.

Lengthened Off Time (LOT) Test. The LOT test is also used where malingering is suspected. This is basically a Bekesy test with the period between pulses lengthened and unequal to the duration of the pulse itself, (e.g., 800 msec off and 200 msec on). This temporal pattern magnifies the difference between the pulsed and continuous tracings, making the identification of possible malingering easier.

Sensitized Speech Tests. These are tests in which the auditory stimulus is speech that has been altered, either in the amplitude, temporal, or frequency domain. They are used when a central auditory disorder is suspected. "Central" is defined as a site of lesion somewhere in the brainstem or cortical auditory areas. Pure-tone tests are not sufficiently complex in nature to identify these lesions. In general, as the site of lesion proceeds centrally in the auditory system, the tests to identify it need to become more and more complex in structure. The flight surgeon's contact with this type of test information would be quite rare in the active duty population. It would more likely occur in the retired or dependent groups.

Impedance Audiometry. This is actually a subbattery of tests. Figure 8-9 shows a pictorial diagram of a typical impedance audiometer.

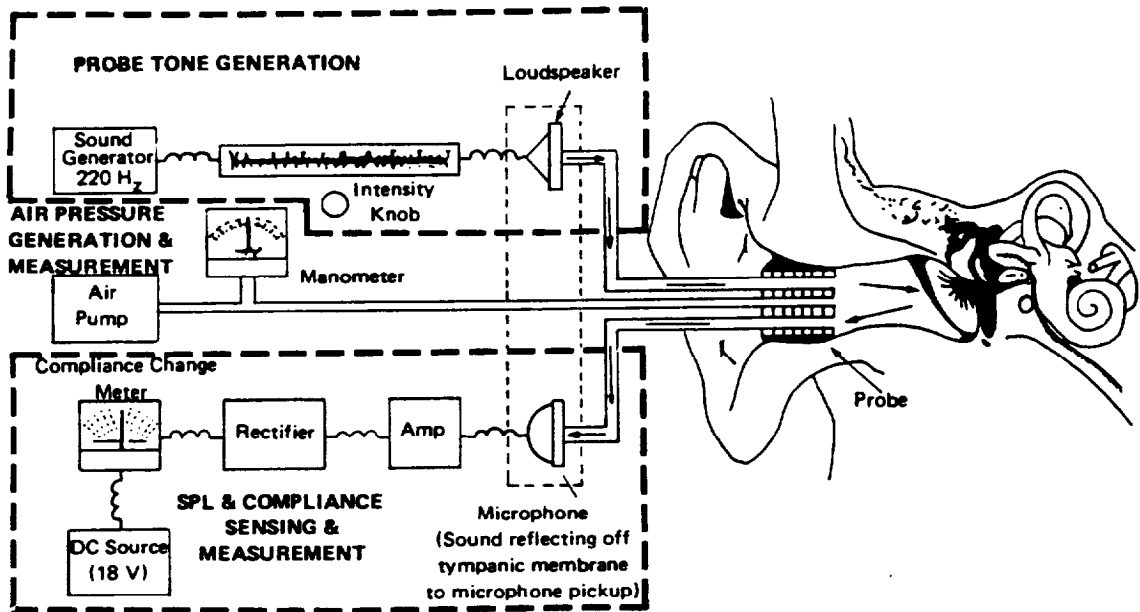

Figure 8-9. Major functional parts of the impedance measurement system (*Impedance Audiometers*, 1976).

This device measures various mechanical aspects of the middle ear. Four general measurements are obtained using the impedance audiometer. These are:

1. Stapedius reflex thresholds - ipsilateral and contralateral.
2. Static compliance - the inverse of impedance and expressed in cc or ml.
3. Middle ear pressure - expressed in MMW or daPa (deca Pascals).
4. Tympanogram - a dynamic plot of compliance as a function of externally applied pressure.

A probe tip (Figure 8-9) is inserted into the test ear and an airtight seal is obtained before testing begins. A standard earphone is placed over the contralateral ear. There are three holes in the probe tip: one is to introduce a tone into the space created between the tip of the probe and the tympanic membrane; the other leads to a microphone which measures the SPL in the space, and the third is used to introduce air into the space (either negative or positive pressure relative to normal atmospheric pressure can be achieved).

Tympanograms are generated automatically by the machine and are recorded on an associated plotter. From this plot, the middle ear pressure is obtained. The static compliance measure is calculated from the difference in volume between the resting compliance measurement and the measure taken with 200 MMW (equivalent) pressure. Stapedius reflex thresholds are determined by introducing an acoustic stimulus at various amplitudes through the earphone. When the amplitude is high enough (70 to 90 dB SPL for pure tones), the stapedius will contract. Since this is a consensual reflex that stiffens both tympanic membranes, it can be monitored on the probe side. The contraction shows up as a change on the compliance meter indicating lowered compliance (i.e., higher impedance).

In addition to defining middle ear problems, impedance audiometry can yield useful information in helping to identify the following conditions (1) acoustic neuroma, through the stapedius reflex decay test, (2) facial nerve site of lesion, (3) Eustachian tube status, (4) fistula, (5) functional hearing loss, volitionally or psychogenically based, and (6) recruitment, through the Metz test (stapedial reflex threshold measurement. Compare to the auditory thresholds).

Interpretation of Hearing Tests

Hearing Loss Classification Systems

The three most frequently encountered types of hearing loss are sensorineural, conductive, and mixed. A conductive loss exists because of a mechanical blockage in the auditory system. The specific site of the problem could involve the pinna, external auditory meatus, the tympanic membrane, or the middle ear cavity. A sensorineural loss reflects, in general, damage to the cochlear nerve cells and fibers in the eighth nerve trunk. Through differential diagnostic testing, this type of loss could be specifically identified as sensory (cochlear) or neural (eighth nerve trunk). A mixed loss is simply a combination of conductive and sensorineural components. Table 8-8 shows the classification criteria for the three types of losses. Note that the criteria include only air and bone conduction HL information. All dB values are referenced to audiometric "zero" except air-bone gap which is the dB difference between air conduction and bone conduction HLs at any given frequency. A comparison of these HL relationships is made in Figure 8-10, utilizing the audiogram code (Figure 8-5). It should be noted that Figure 8-10 indicates HLs for only one frequency. In practice, HLs would be determined at all frequencies shown on the audiogram.

Classification of hearing by severity of loss is shown in Table 8-9. The average HL or pure-tone average (PTA) should agree with the SRT by ± 5 dB in the greatest proportion of hearing loss types. This relationship is very often used as an internal reliability check between pure-tone and speech test results. Someone attempting to feign a hearing loss generally would have a much bet-

ter SRT than would be predicted from the pure-tone average. A hearing aid generally would not be considered for a patient, unless the loss had reached the “moderate” classification in the better ear.

Table 8-8

Pure Tone Audiometric Criteria for Classification of Mixed, Conductive, and Sensorineural Impairments

	Sensorineural	Conductive	Mixed
Air Conduction Threshold	Worse than 25 dB	Worse than 25 dB	Worse than 25 dB
Bone Conduction Threshold	Worse than 15 dB	Better than 15 dB	Worse than 15 dB
Air-Bone Gap	Less than 10 dB	More than 10 dB	More than 10 dB

Figure 8-10. A comparison of hearing threshold levels for the three types of hearing losses. The symbols are defined in Figure 8-5.

	Sensorineural	Conductive	Mixed
Air Conduction Threshold	Worse than 25 dB	Worse than 25 dB	Worse than 25 dB
Bone Conduction Threshold	Worse than 15 dB	Better than 15 dB	Worse than 15 dB
Air-Bone Gap	Less than 10 dB	More than 10 dB	More than 10 dB

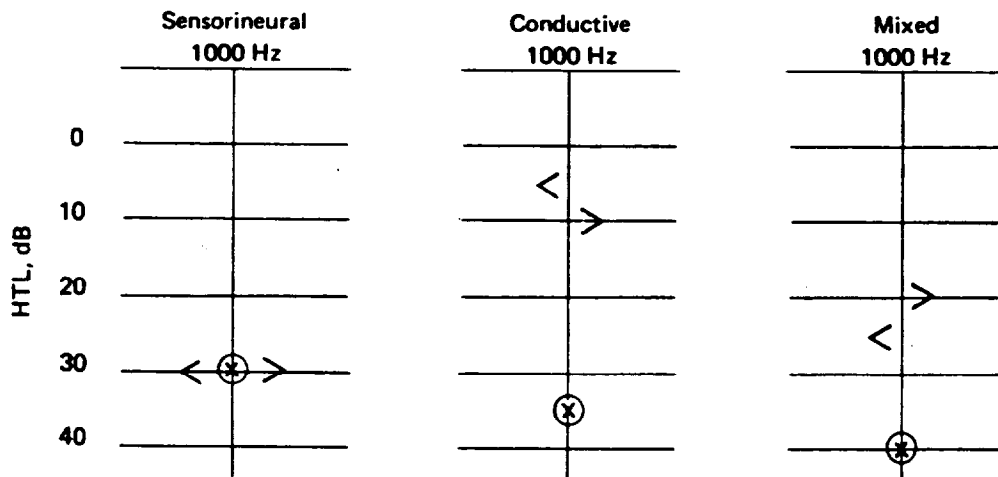

Table 8-9

Classification of Hearing Impairment by Severity

Average H L*	Classification	Ability to Hear Speech
0-25 dB	WNL	No Difficulty Even with Faint Speech
26-40	Mild	Difficulty With Faint Speech Only
41-55	Moderate	Frequent Difficulty With Normal Speech
56-70	Moderately Severe	Frequent Difficulty With Loud Speech
71-90	Severe	Only Hears Shouted or Amplified Speech
91 +	Profound	Usually Cannot Understand Even Amplified Speech

*Average Hearing Threshold Level (H L) is the arithmetic mean of the thresholds for pure tone frequencies of 500, 1000, and 2000 Hertz. Average H L can also be referred to as the pure tone average (PTA). The PTA correlates very highly with the actual speech reception threshold measurement.

(adapted from Davis & Silverman, 1970).

Speech discrimination scores are more qualitative in their interpretation than are SRTs. The general concept is that in sensorineural hearing loss, the speech discrimination score will be directly proportional to the degree of system damage (cochlear hair cells or neural fibers). There is no quantitative way to predict speech discrimination ability from the pure-tone audiogram. Sensorineural hearing loss will be the most common hearing loss seen by the flight surgeon. Most persons with sensorineural losses have greater difficulty with speech discrimination in noise than in quiet. This is because the noise further reduces their ability to hear high-frequency consonants which carry the preponderance of speech information. Also, these patients may be very much annoyed by loud sounds (because of the recruitment phenomenon) and make less than ideal candidates for hearing aid use. Discrimination scores of 80 percent or better on the W-I lists are considered good, 60 to 70 percent, fair, and 60 percent and less, poor. The naval aviator's speech discrimination test (NASDT) requires a minimum score of 70 percent for a passing grade. This is a speech-in-noise test and is given to establish a waiver when pure-tone hearing standards are not met by the patient.

Differential Diagnosis

Advanced hearing tests are useful adjuncts to otological diagnosis because they help identify the focus of the hearing disorder. There is no test accurate enough to do the job alone. One should take advantage of the increased sensitivity inherent in the pattern of results from a properly selected test battery. A very useful multiple test battery, described in Table 8-10, consists of the SISI test, ABLB, and Bekesy audiometry, SISI and ABLB scoring are shown in Table 8-10.

Table 8-10

Ideal Test Results for Each Locus

Locus	SISI	Békésy Type	ABLB
Middle Ear	-	I	N
Cochlea	+	II	P or C
Eighth Nerve	-	III or IV	N

Possible Test Results for Each Locus
And the Likelihood of Occurrence

Locus	Likelihood	SISI	Békésy Type	ABLB
Middle Ear Disorders	In 67 of 100	-	I	N
	In 14 of 100	?	I	N
	In 10 of 100	+	I	N
	In 5 of 100	-	II	N
	In 4 of 100	?	II	N
Cochlear Disorders	In 50 of 100	+	II	C
	In 25 of 100	+	II	N
	In 20 of 100	+	II	P
	In 5 of 100	+	I	P
Eighth Nerve Disorders	In 64 of 100	-	III	N
	In 18 of 100	-	IV	N
	In 9 of 100	-	IV	P
	In 9 of 100	?	IV	P

Note: SISI scores are coded as follows: (-) = 0 to 20%, (?) = 20 to 60%, (+) = 60 to 100%.

Loudness Balance results are coded as follows: N = no recruitment, P = partial recruitment, C = complete recruitment.

(adapted from Jerger, 1962, published by permission of the American Speech and Hearing Association).

The four basic types of Bekesy audiograms are shown in Figure 8-11. Not all patients with the pathologies indicated will display the specific type of audiogram shown in the figure. In fact, a certain percentage of subjects with middle ear disorders show Type II Bekesy tracings. This is shown in Table 8-10 to be about nine percent.

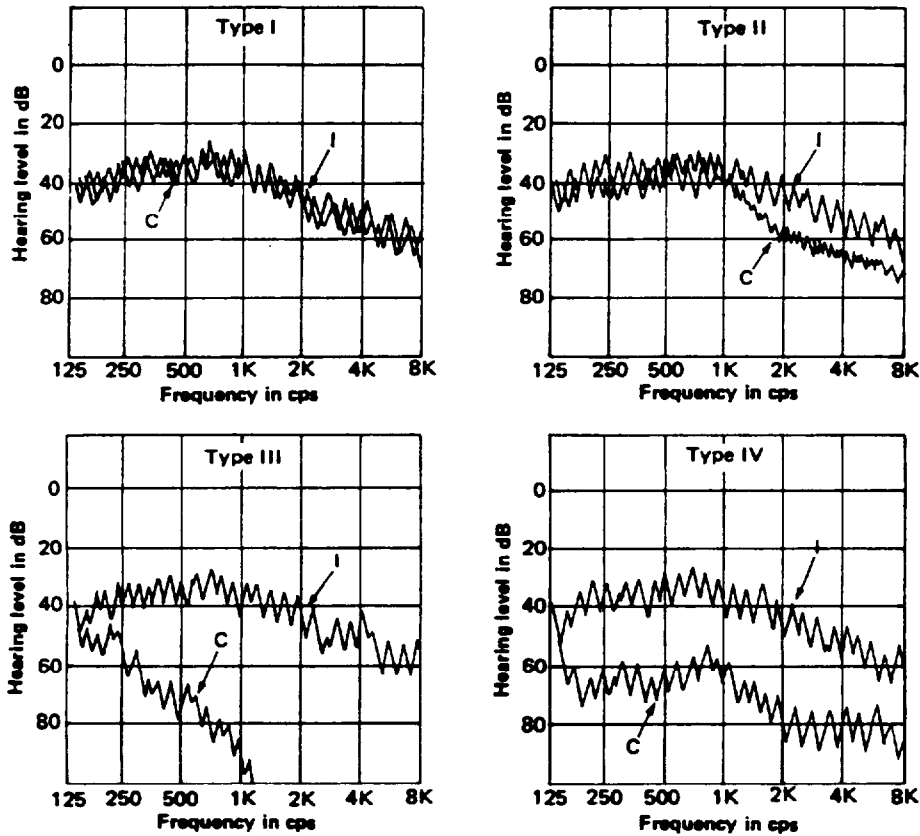

Figure 8-11. The four types of Bekesy audiograms: Type I occurs in normal ears and in disorders of the middle ear. Type II occurs in disorders of the cochlea. Type III and Type IV occur in disorders of the eighth nerve (Jerger, 1960, published by permission of *Journal of Speech and Hearing Research*).

Johnson (1968) further demonstrated the necessity for a test battery approach to diagnosis with the Bekesy data on confirmed cases of acoustic neuroma given in Table 8-11. This data shows that 61 percent of the patients produced appropriate tracings relating to acoustic neuroma, while 41 percent produced tracings generally associated with cochlear and middle ear pathologies. Clearly, a test battery approach is a necessity. The probability of error when correlating several test results rather than depending on a single piece of information is greatly reduced.

Table 8-11

Bekesy Data for Confirmed Cases of Acoustic Neuroma

Percent Cases	Békésy Type
24	IV
37	III
33	II
8	I

(data from Johnson, 1968).

Another category of Bekesy trace is the Type V. This is commonly seen in patients attempting to feign a hearing loss. It has essentially a Type IV configuration, except that the continuous and pulsed tracings are reversed (i.e., hearing for the continuous tone is shown as being better than hearing for the pulsed tone). Perceptually, the loudness of a supra-threshold tone is greater for a continuous signal than for a pulsed signal. What the patient is actually doing is tracing an equal loudness contour for each type of signal. It should be noted that this test can be done with some of the self-recording screening audiometers in the fleet. All that is necessary is to be able to select either a pulsed or continuous tone on the instrument. In a clinical setting, the LOT test, mentioned previously, would be done and would in most cases accentuate the dB separation between the two tracings.

Some clinics have abandoned entirely Bekesy and SISI testing as just described; substituting instead ABR and stapedial reflex measurements. Clinics still utilizing Bekesy testing are employing modifications of the conventional techniques which have been shown to improve accuracy. These are the Bekesy comfortable loudness technique (BCL) and reverse Bekesy tracings (Brunt, 1985). Bekesy testing is much more effective in identifying sensory problems than it is in identifying retrocochlear problems.

Impedance audiometry is becoming a routine tool in many naval hospitals and some regional branch clinics. Figure 8-12 illustrates six types of tympanometric configurations. Shown below each one are the possible associated pathologies and the type identification for that particular configuration.

Possible Test Findings - Illustrated Cases

The audiologic findings in ten hypothetical cases are presented in Figures 8-13 through 8-21. Each Figure represents typical audiologic findings related to the stated diagnosis. The cases are

arranged roughly according to the probability that the type of disorder would be seen by the flight surgeon (i.e., the first case is most probable and the last case is the least probable).

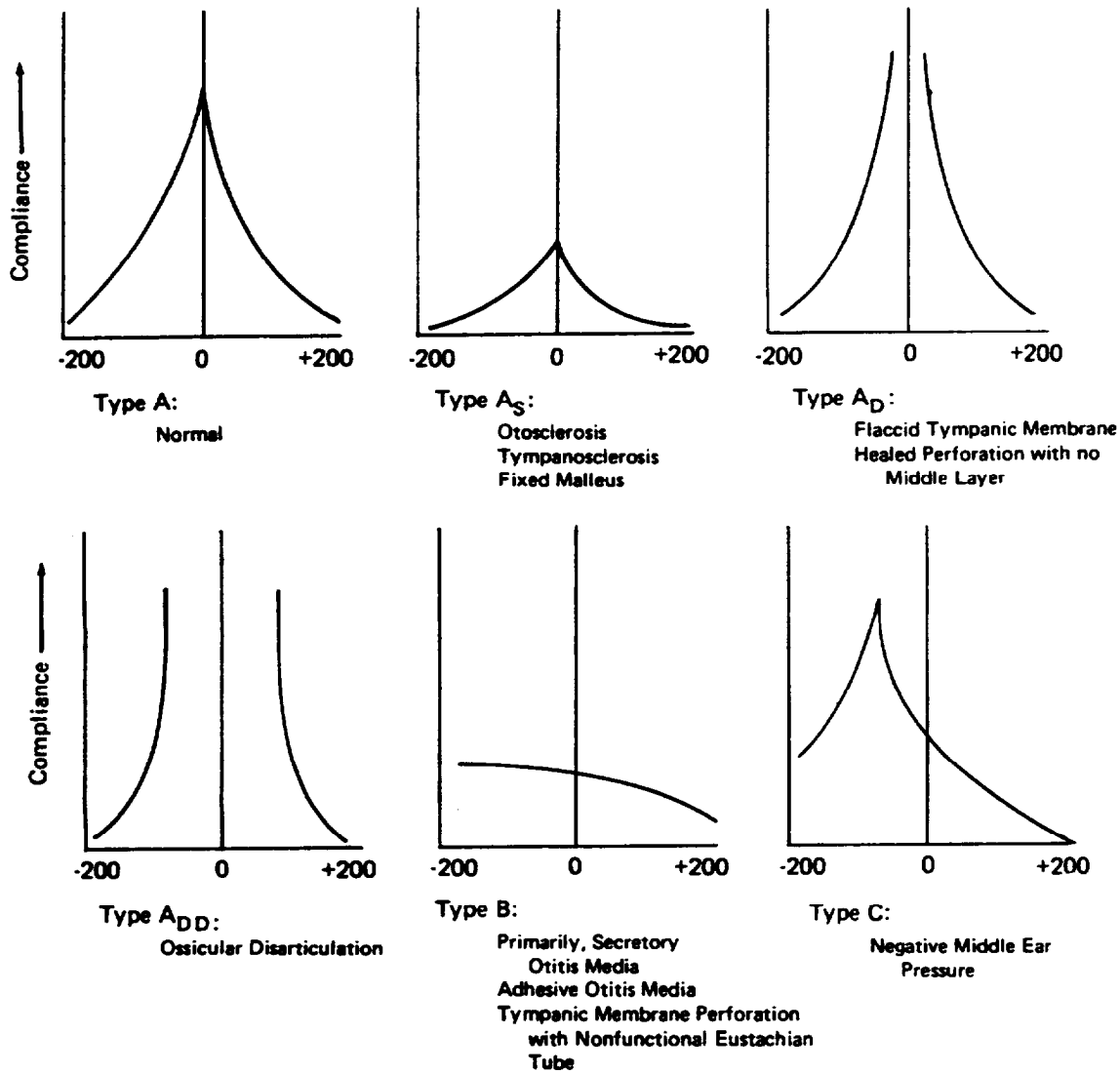

Figure 8-12. Tympanometric configurations.

All cases include pure-tone and speech audiometric findings and identification of the type and severity of loss (see Table 8-8 and 8-9, respectively). In appropriate instances, tone decay, SISI, Bekesy, and impedance audiometric test results are shown (lower left of each figure).

By studying the figures and referring back to the information already presented, the flight surgeon should gain a good appreciation of the area of interpretation of audiological results.

HEARING EVALUATION REPORT
Frequency, in Hertz (Hz)

SSAN: _____ DATE: _____

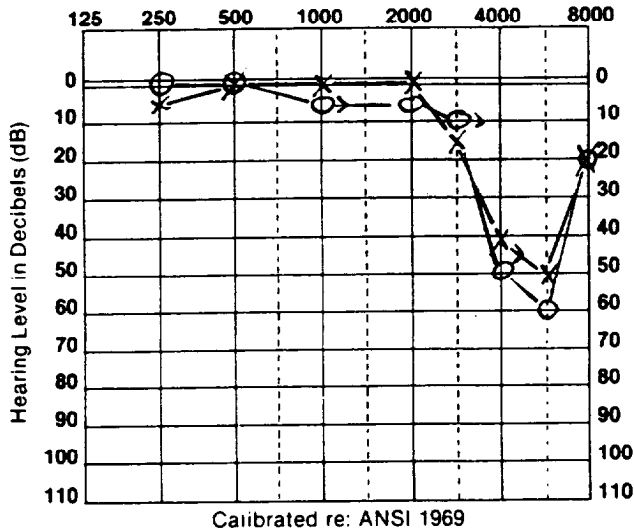

SYMBOL KEY

	Right	Left	Sound Field
AC UNMASKED	○	×	
AC MASKED	△	□	
BC UNMASKED	>	<	
BC MASKED	▽	◁	
NO RESPONSE	↘	↙	
SOUND FIELD			S
AIDED SOUND FIELD			

DEFINITIONS

CNT: Could not test
DNT: Did not test

RELIABILITY: Good Fair Poor

	Pure Tone Avg.		Speech Tests							
	2 freq.	3 freq.	SRT	PB Max	Level	MCL	UCL	SF	SRT	PB MAX
Right	dB	dB	5 dB	90 %	40			Unaided		%
Left	dB	dB	5 dB	92 %	40			Aided		%

OTHER TESTS: R L
Tone Decay Test: Neg Neg
SISI Test: Pos Pos
Bekeyes Type: I I

TYMPANOGRAMS-SUMMARY

ET FUNCTION	EAR	TYPE	CONTRA REFLEX	IPSI REFLEX	REFLEX DECAY	METZ	TGRAMS ATTACHED
	RT						
	LT						

AUDIOMETRIC DATA RE: ANSI S3.6				LEFT						RIGHT					
				500	1000	2000	3000	4000	8000	500	1000	2000	3000	4000	8000
CURRENT AUDIOGRAM DATE	year	month	day												
REFERENCE AUDIOGRAM DATE	year	month	day												
THRESHOLD SHIFT															

COMMENTS: Type: Bilateral, high frequency, sensory neural
Diagnosis: Noise induced

Signature: _____

Figure 8-13. Possible audiological findings in noise induced hearing loss.

NAME: _____

HEARING EVALUATION REPORT

SSAN: _____ DATE: _____

Frequency, in Hertz (Hz)

SYMBOL KEY

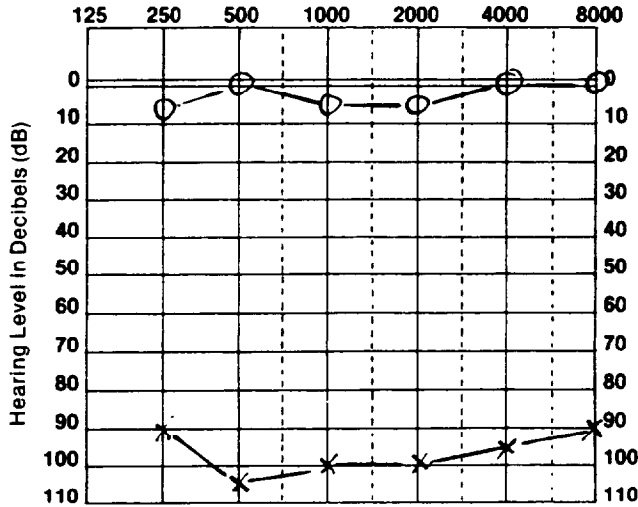

	Right	Left	Sound Field
AC UNMASKED	○	×	
AC MASKED	△	□	
BC UNMASKED	>	<	
BC MASKED	▽	◁	
NO RESPONSE	↘	↙	
SOUND FIELD			S
AIDED SOUND FIELD			.

DEFINITIONS

CNT: Could not test
DNT: Did not test

RELIABILITY: Good Fair Poor

	Pure Tone Avg.		Speech Tests							
	2 freq.	3 freq.	SRT	PB Max	Level	MCL	UCL	SF	SRT	PB MAX
Right	dB	dB	10 dB	95 %	45			Unaided		%
Left	dB	dB	5 dB	100 %	45			Aided		%

OTHER TESTS:
 Tone Decay Test: R DNT L DNT
 SISI Test: DNT DNT
 Bekesy Type: V DNT

TYMPANOGRAMS-SUMMARY

ET FUNCTION	EAR	TYPE	CONTRA REFLEX	IPSI REFLEX	REFLEX DECAY	METZ	TGRAMS ATTACHED
	RT	A	Present				
	LT	A	Present				

AUDIOMETRIC DATA RE: ANSI S3.6				LEFT				RIGHT							
CURRENT AUDIOGRAM DATE	year	month	day	500	1000	2000	3000	4000	8000	500	1000	2000	3000	4000	8000
REFERENCE AUDIOGRAM DATE	year	month	day												
THRESHOLD SHIFT															
	+ = Poorer - = Better														

COMMENTS: Type: Functional/non-organic

Signature: _____

Figure 8-14. Possible audiological findings in functional hearing loss.

NAME: _____

HEARING EVALUATION REPORT
Frequency, in Hertz (Hz)

SSAN: _____ DATE: _____

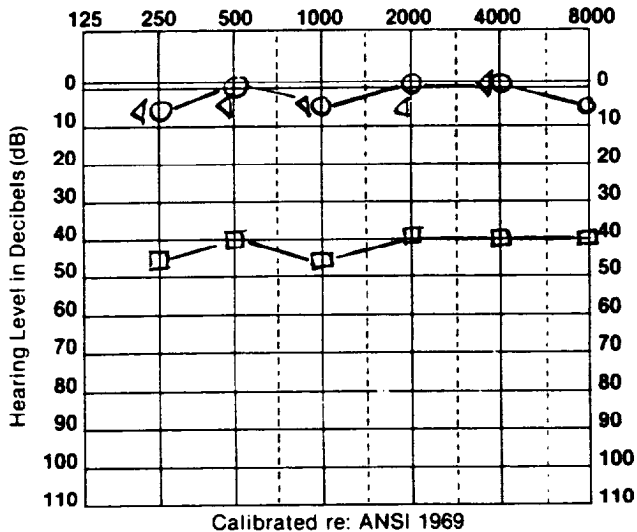

SYMBOL KEY

	Right	Left	Sound Field
AC UNMASKED	○	×	
AC MASKED	△	□	
BC UNMASKED	>	<	
BC MASKED	▷	◁	
NO RESPONSE	↘	↙	
SOUND FIELD			S
AIDED SOUND FIELD			.

DEFINITIONS

CNT: Could not test
DNT: Did not test

RELIABILITY: Good Fair Poor

	Pure Tone Avg.		Speech Tests							
	2 freq.	3 freq.	SRT	PB Max	Level	MCL	UCL	SF	SRT	PB MAX
Right	dB	dB	0 dB	96 %	40			Unaided		%
Left	dB	dB	40 dB	100 %	80			Aided		%

OTHER TESTS: R L Freq
Tone Decay Test: Neg Neg 4kHz
SISI Test: DNT DNT

TYMPANOGRAMS-SUMMARY

ET FUNCTION	EAR	TYPE	CONTRA REFLEX	IPSI REFLEX	REFLEX DECAY	METZ	TGRAMS ATTACHED
	RT	A	Absent				
	LT	B	Absent				

AUDIOMETRIC DATA RE: ANSI S3.6				LEFT				RIGHT							
CURRENT AUDIOGRAM DATE	year	month	day	500	1000	2000	3000	4000	8000	500	1000	2000	3000	4000	8000
REFERENCE AUDIOGRAM DATE	year	month	day												
THRESHOLD SHIFT															
+ = Poorer - = Better															

COMMENTS: Type: Unilateral, conductive
Severity: Mild
Diagnosis: Otitis media

Signature: _____

Figure 8-15. Possible audiological findings in unilateral otitis media.

NAVHOSP PNCLA 6120/22 (Rev. 1-87)

NAME: _____

HEARING EVALUATION REPORT
Frequency, in Hertz (Hz)

SSAN: _____ DATE: _____

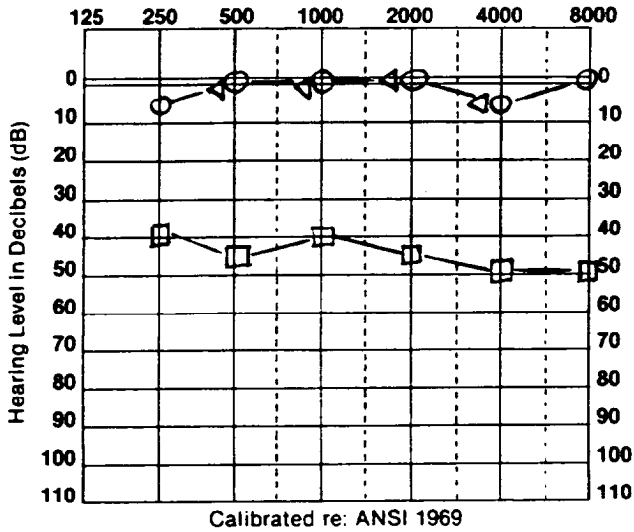

SYMBOL KEY

	Right	Left	Sound Field
AC UNMASKED	○	×	
AC MASKED	△	□	
BC UNMASKED	>	<	
BC MASKED	▷	◁	
NO RESPONSE	↘	↙	
SOUND FIELD			S
AIDED SOUND FIELD			.

DEFINITIONS

CNT: Could not test
DNT: Did not test

RELIABILITY: Good Fair Poor

	Pure Tone Avg.		Speech Tests							
	2 freq.	3 freq.	SRT	PB Max	Level	MCL	UCL	SF	SRT	PB MAX
Right	dB	dB	5 dB	100%	40			Unaided		%
Left	dB	dB	45 dB	100%	85 (Masked AD)			Aided		%

OTHER TESTS:

TYMPANOGRAMS-SUMMARY

ET FUNCTION	EAR	TYPE	CONTRA REFLEX	IPSI REFLEX	REFLEX DECAY	METZ	TGRAMS ATTACHED
	RT	A	Absent				
	LT	ADD	Absent				

AUDIOMETRIC DATA RE: ANSI S3.6				LEFT						RIGHT					
CURRENT AUDIOGRAM DATE	year	month	day	500	1000	2000	3000	4000	6000	500	1000	2000	3000	4000	6000
REFERENCE AUDIOGRAM DATE	year	month	day												
THRESHOLD SHIFT															
	+ = Poorer - = Better														

COMMENTS: Type: Unilateral, conductive
Severity: Moderate
Diagnosis: Ossicular discontinuity secondary to head trauma.
Signature: _____

Figure 8-16. Possible audiometric findings in Ossicular discontinuity.

HEARING EVALUATION REPORT

SSAN: _____ DATE: _____

Frequency, in Hertz (Hz)

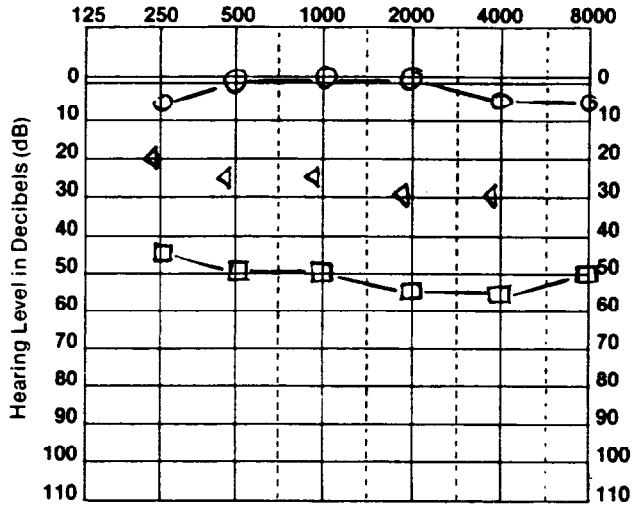

SYMBOL KEY

	Right	Left	Sound Field
AC UNMASKED	○	×	
AC MASKED	△	□	
BC UNMASKED	>	<	
BC MASKED	▷	◁	
NO RESPONSE	↘	↙	
SOUND FIELD			S
AIDED SOUND FIELD			.

DEFINITIONS

CNT: Could not test
DNT: Did not test

RELIABILITY: Good Fair Poor

	Pure Tone Avg.		Speech Tests							
	2 freq.	3 freq.	SRT	PB Max	Level	MCL	UCL	SF	SRT	PB MAX
Right	dB	dB	0 dB	98%	40			Unaided		%
Left	dB	dB	50 dB	84%	90 (Masked AD)			Aided		%

OTHER TESTS: R L Freq.
Tone decay test: Neg DNT;

TYMPANOGRAMS-SUMMARY

ET FUNCTION	EAR	TYPE	CONTRA REFLEX	IPSI REFLEX	REFLEX DECAY	MEZ	TGRAMS ATTACHED
	RT	A	Absent				
	LT	B	Absent				

AUDIOMETRIC DATA RE: ANSI S3.6				LEFT						RIGHT					
				500	1000	2000	3000	4000	6000	500	1000	2000	3000	4000	6000
CURRENT AUDIOGRAM DATE	year	month	day												
REFERENCE AUDIOGRAM DATE	year	month	day												
THRESHOLD SHIFT				/						/					
				+ = Poorer - = Better											

COMMENTS: Type: Unilateral, mixed
Severity: Moderate
Diagnosis: chronic OM, AS with sensory neural involvement
Signature: _____

Figure 8-17. Possible audiological findings in chronic otitis media.

NAVHOSP PNCLA 6120/22 (Rev. 1-87)

NAME: _____

HEARING EVALUATION REPORT
Frequency, in Hertz (Hz)

SSAN: _____ DATE: _____

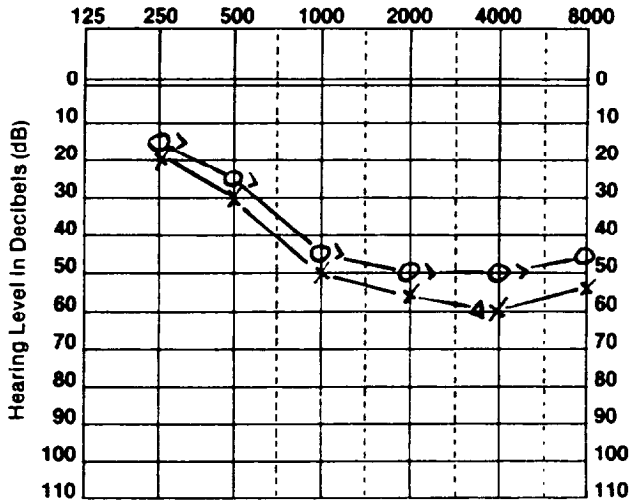

Calibrated re: ANSI 1969

SYMBOL KEY

	Right	Left	Sound Field
AC UNMASKED	○	×	
AC MASKED	△	□	
BC UNMASKED	>	<	
BC MASKED	▷	◁	
NO RESPONSE	↘	↙	
SOUND FIELD			S
AIDED SOUND FIELD			.

DEFINITIONS

CNT: Could not test
DNT: Did not test

RELIABILITY: Good Fair Poor

	Pure Tone Avg.		Speech Tests							
	2 freq.	3 freq.	SRT	PB Max	Level	MCL	UCL	SF	SRT	PB MAX
Right	dB	dB	45 dB	88 %	85			Unaided		%
Left	dB	dB	50 dB	85 %	90			Aided		%

OTHER TESTS: R L Freq.
Tone decay: Neg Neg 4kHz
SISI test: ? ?
Bekeyes type: IV IV

TYMPANOGRAMS-SUMMARY

ET FUNCTION	EAR	TYPE	CONTRA REFLEX	IPSI REFLEX	REFLEX DECAY	METZ	TYGRAMS ATTACHED
	RT	A	85		Neg	Pos	
	LT	A	80		Neg	Pos	

AUDIOGRAM DATA RE: ANSI S3.6				LEFT						RIGHT					
				500	1000	2000	3000	4000	8000	500	1000	2000	3000	4000	8000
CURRENT AUDIOGRAM DATE	year	month	day												
REFERENCE AUDIOGRAM DATE	year	month	day												
THRESHOLD SHIFT + = Poorer - = Better															

COMMENTS: Type: Bilateral, sensory neural
Severity: Moderate
Diagnosis: Ototoxicity

Signature: _____

Figure 8-18. Possible audiological findings in drug ototoxicity.

NAME: _____

HEARING EVALUATION REPORT
Frequency, in Hertz (Hz)

SSAN: _____ DATE: _____

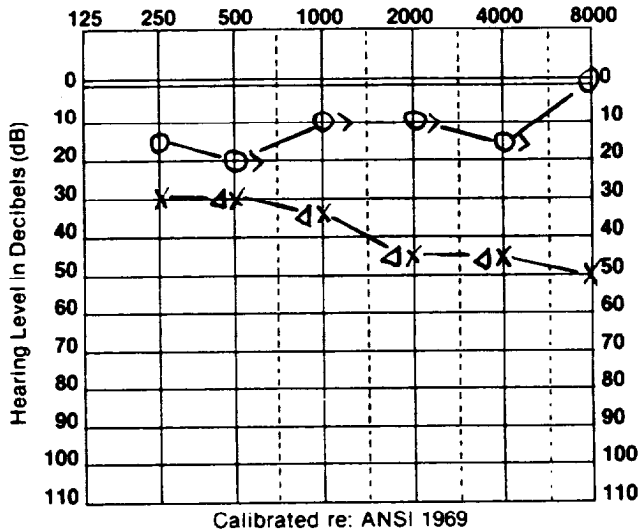

SYMBOL KEY

	Right	Left	Sound Field
AC UNMASKED	○	×	
AC MASKED	△	◻	
BC UNMASKED	>	<	
BC MASKED	▽	◁	
NO RESPONSE	↘	↙	
SOUND FIELD			S
AIDED SOUND FIELD			.

DEFINITIONS

CNT: Could not test
DNT: Did not test

RELIABILITY: Good Fair Poor

	Pure Tone Avg.		Speech Tests							
	2 freq.	3 freq.	SRT	PB Max	Level	MCL	UCL	SF	SRT	PB MAX
Right	dB	dB	10 dB	95%	50			Unaided		%
Left	dB	dB	45 dB	38%	85 (Masked AD for PB Max)			Aided		%

OTHER TESTS:
Tone Decay Test: R Neg Pos 4kHz
L Pos Neg 2kHz
Neg Pos 1kHz
SISI Test: DNT Neg 4kHz
Bekeasy Type: I III

TYMPANOGRAMS-SUMMARY

ET FUNCTION	EAR	TYPE	CONTRA REFLEX	IPSI REFLEX	REFLEX DECAY	METZ	TYMOGRAMS ATTACHED
	RT	A	Present		DNT		
	LT	A	Absent		Positive		

AUDIOMETRIC DATA RE: ANSI S3.5				LEFT						RIGHT					
CURRENT AUDIOGRAM DATE	year	month	day	500	1000	2000	3000	4000	6000	500	1000	2000	3000	4000	6000
REFERENCE AUDIOGRAM DATE	year	month	day												
THRESHOLD SHIFT															
	+ = Poorer - = Better														

COMMENTS: Type: Unilateral, neural
Severity: Moderate
Diagnosis: Acoustic neuroma AS.
Signature: _____

Figure 8-19. Possible audiological findings in acoustic neuroma.

NAVHOSP PNCLA 6120/22 (Rev. 1-87)

NAME: _____

HEARING EVALUATION REPORT
Frequency, in Hertz (Hz)

SSAN: _____ DATE: _____

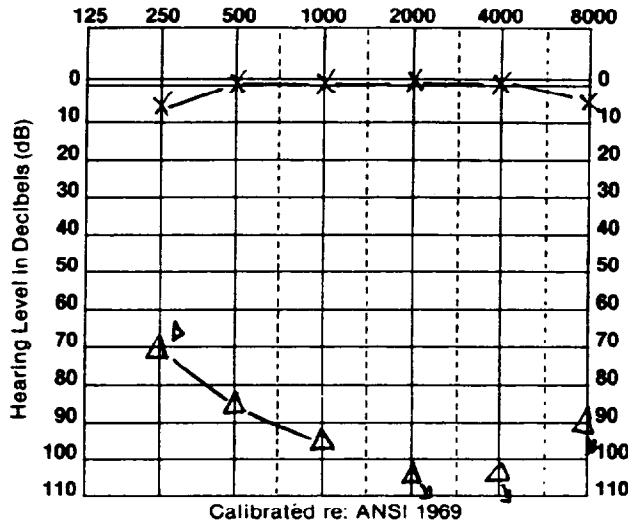

SYMBOL KEY

	Right	Left	Sound Field
AC UNMASKED	○	×	
AC MASKED	△	□	
BC UNMASKED	>	<	
BC MASKED	▽	◁	
NO RESPONSE	↘	↙	
SOUND FIELD			S
AIDED SOUND FIELD			.

DEFINITIONS

CNT: Could not test
DNT: Did not test

RELIABILITY: Good Fair Poor

	Pure Tone Avg.		Speech Tests							
	2 freq.	3 freq.	SRT	PB Max	Level	MCL	UCL	SF	SRT	PB MAX
Right	dB	dB	CNT dB	CNT %				Unaided		%
Left	dB	dB	0 dB	100%	40			Aided		%

OTHER TESTS: R L Freq
Tone Decay Test: Neg Neg 1kHz

TYMPANOGRAMS-SUMMARY

ET FUNCTION	EAR	TYPE	CONTRA REFLEX	IPSI REFLEX	REFLEX DECAY	NETZ	TGRAMS ATTACHED
	RT	A	Absent				
	LT	A	85				

AUDIOMETRIC DATA RE: ANSI S3.6	LEFT						RIGHT					
	500	1000	2000	3000	4000	6000	500	1000	2000	3000	4000	6000
CURRENT AUDIOGRAM DATE year month day												
REFERENCE AUDIOGRAM DATE year month day												
THRESHOLD SHIFT + = Poorer - = Better	/					/	/					/

COMMENTS: Type: Unilateral, sensory neural
Severity: Profound
Diagnosis: Mumps as child
Signature: _____

Figure 8-20. Possible audiological findings in epidemic parotitis.

HEARING EVALUATION REPORT
Frequency, in Hertz (Hz)

SSAN: _____ DATE: _____

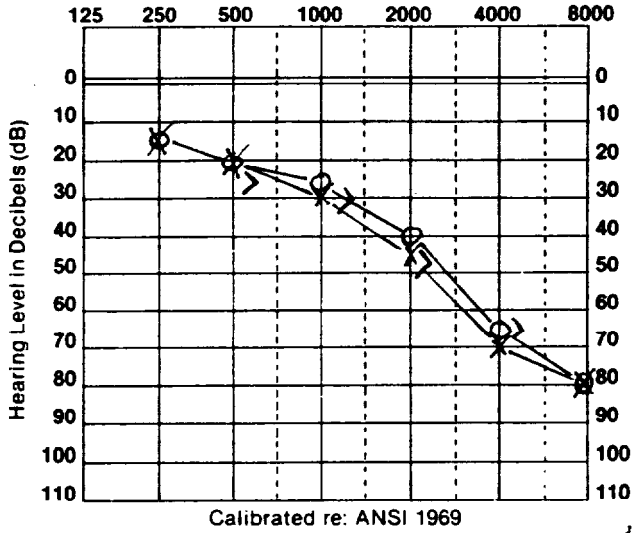

SYMBOL KEY

	Right	Left	Sound Field
AC UNMASKED	○	×	
AC MASKED	△	□	
BC UNMASKED	>	<	
BC MASKED	▽	◁	
NO RESPONSE	↘	↙	
SOUND FIELD			S
AIDED SOUND FIELD			.

DEFINITIONS

CNT: Could not test
DNT: Did not test

RELIABILITY: Good Fair Poor

	Pure Tone Avg.		Speech Tests							
	2 freq.	3 freq.	SRT	PB Max	Level	MCL	UCL	SF	SRT	PB MAX
Right	dB	dB	30 dB	68 %	70			Unaided		%
Left	dB	dB	30 dB	64 %	70			Aided		%

OTHER TESTS: R L Freq
Tone Decay Test: Pos Pos 2kHz
Neg Neg 1kHz
SISI Test: Neg Neg

		TYMPANOGRAMS-SUMMARY											
ET FUNCTION	EAR	TYPE	CONTRA REFLEX	IPSI REFLEX	REFLEX DECAY	METZ	TGRAMS ATTACHED						
	RT												
	LT												

AUDIOMETRIC DATA RE: ANSI S3.6				LEFT						RIGHT					
CURRENT AUDIOGRAM DATE	year	month	day	500	1000	2000	3000	4000	6000	500	1000	2000	3000	4000	6000
REFERENCE AUDIOGRAM DATE	year	month	day												
THRESHOLD SHIFT				/						/					
				+ Poorer						- Better					

COMMENTS: Type: bilateral, sensory neural
Severity: By PTA mild but moderately severe considering the low PB scores.
Diagnosis: Presbycusis

Signature: _____

Figure 8-21. Possible audiological findings in presbycusis.

SECTION III

THE NAVY HEARING CONSERVATION PROGRAM (HCP)

Introduction

Exposure to hazardous levels of noise is inherent to many naval operations. Such exposure may result from diverse weapon systems, the propulsion systems of weapon platforms, or the industrial activities which support them. To date, adequate noise control has not been incorporated in many systems because of economic factors or because noise control was not included in the original development or procurement process. As a result, there has been an increasing concern about the safety and health aspects of excessive exposure to noise in daily operations.

The Navy Hearing Conservation Program (HCP) is a command preventive program generally administered by medical. Its purpose is to prevent the loss of hearing in military and civilian personnel who must work in hazardous noise environments. This is to be accomplished by a comprehensive program which includes noise exposure analyses, personal hearing protective devices, monitoring audiometry, education, and noise control engineering. The HCP had its beginnings in the aviation community, probably due to the introduction of jet aircraft. It has now expanded to all Navy operations.

In years past it was more or less accepted that a hearing loss accompanied certain jobs. Such labels as "aviator's notch" or "boilermaker's ear" were accepted as part of the job. During the 1960's, however, change in attitudes and values occurred. In 1970 Congress passed the Occupational Safety and Health Act (OSHACT) which required employers to provide a safe and healthy work environment. Originally Executive Order 11807 and more recently Executive Order 12196 extended the OSHACT to all branches of the federal government, including the Navy. This order requires the Navy to develop and implement programs to prevent any employee hearing loss arising from exposure to noise in the workplace.

In many Navy and Marine Corps facilities, hearing conservation is being accomplished. Audiograms at these facilities show very few cases of hearing loss because hearing protective devices are worn on and off the job, noise abatement and control is being implemented, and education is bringing about an awareness of the problem of noise and its effect on hearing.

There is, however, considerable variability in effectiveness among facilities. At some facilities individuals are suffering noise induced hearing loss. Why are some programs more successful than others? The answer, though not simple, seems to lie with the perception of priorities and the

Otorhinolaryngology

limits of resources. It has to do with people, both the protectors and the protected. This chapter will discuss ways to implement a successful hearing conservation program.

Implementation of HCP

OPNAVINST 5100.23B outlines responsibilities of commanding officers in establishing and maintaining HCP's. NAVMEDCOMINST 6260.5 provides guidance for implementing the medical departments responsibilities. This instruction assigns the following actions and responsibilities:

All ships and stations having Medical Department personnel (less regionalized COMNAVMEDCOM activities and NAVENVIRHLHCEN) shall:

1. Appoint a responsible individual to coordinate all medical aspects of occupational noise control and hearing conservation.
2. Assure identification and characterization of noise hazard areas within their purview according to paragraph two of enclosure (1).
3. Assure that hearing conservation audiometry, clinical evaluation, and referrals are performed according to the standards of paragraph three of enclosure (1).
4. Provide for earplug fitting support for military and civilian personnel within their program, according to paragraph four of enclosure (1).
5. Assure certification or training, in accordance with enclosure (1) of this instruction, of Medical Department personnel, sound measurement equipment, audiometers, and hearing test booths involved in the hearing conservation program.
6. Seek support and assistance, as necessary and appropriate, from COMNAVMEDCOM regional activities, or Navy Environmental and Preventive Medicine Units (NAVENP-VNTMEDUs) for those aspects of occupational noise control and hearing conservation in which they are not self-sufficient.

Newly appointed coordinator, of hearing conservation programs should assess their resources and determine what deficiencies exist with their programs. They should determine:

- (1) If noise surveys have identified personnel exposed to hazardous noise and if so, have exposure risk assessments been performed, and: (2) Are required services such as hearing tests, fit-

ting of hearing protective devices, referral guidelines, and educational requirements being met. They should work with: (1) safety specialists to help identify problem areas and to monitor compliance in the wearing of hearing protection; (2) regional audiologists and industrial hygienists (or NAVENPVNTMEDU staff) to plan, coordinate and help perform noise surveys to identify noise hazard areas and equipment, and to identify personnel exposed to noise; (3) supervisors to coordinate all elements of hearing conservation at that level, and; (4) regional occupational health service and ENT service to coordinate all medical aspects of the HCP. This coordinator should ensure that adequately trained personnel are on board to provide services and that adequate audiometric facilities are available. The coordinator should evaluate all audiograms and monitor patient status. Finally, the coordinator should represent the interests of hearing conservation at the command and staff level.

It must be emphasized at all levels that there is no cure for noise-induced hearing loss, only prevention. No one is going to report automatically to the clinic and present themselves as a candidate for a program of hearing loss prevention. When individuals typically seek assistance, significant hearing loss has already occurred. The HCP must provide people to go out into the workplace to identify noise-exposed personnel and to ensure conservation of their priceless sense of hearing.

Noise Measurement and Exposure Analysis

The first step in the identification of noise-hazard areas and equipment, and noise-exposed personnel is the noise survey. The types of surveys and the different reasons for conducting a survey are discussed below.

The preliminary survey may be any type of cursory or informal evaluation of possible noise hazards that any member of the hearing conservation team notices during walk-through of a work area. This could take the form of a response to a call from someone with a complaint of a noisy piece of equipment or noisy process. The rule-of-thumb criterion for this subjective appraisal is that a noise hazard may exist when it becomes necessary to raise your voice at a distance of three feet in order to communicate.

The above may lead to a request for occupational health personnel to perform a noise survey. The survey should result in complete documentation of noise hazards and personnel at risk. Routine noise surveys are required on an annual basis.

An engineering noise analysis is performed when it is necessary to pinpoint noise sources for

Otorhinolaryngology

noise control engineering. Control of noise at the source is the ultimate solution to prevent noise-induced hearing loss.

Noise surveys are required in order to meet both Navy and federal regulations. Specific documentation is required for A-weighted levels and listing of noise-exposed personnel where the noise levels are 84 dB(A) or greater.

Noise survey information is also necessary when a civilian worker files a claim for compensation for hearing loss due to exposure to noise in the workplace. Adjudication by the Office of Workers' Compensation Programs (OWCP) requires a complete noise exposure history including exposures at 84 dB(A) and above for the entire period of employment of the individual by the U.S. Government. For military personnel, a noise exposure history should be available in every health record in order to verify that the hearing loss was due to occupational noise exposure rather than to some other factor.

Audiometry in the HCP

After the noise survey has been conducted and rosters of noise-exposed personnel have been compiled, the other aspects of the HCP are set into motion. Audiometry is one of these elements.

For hearing tests to be valid the following is required:

1. A trained and certified technician.
2. A calibrated audiometer.
3. A certified audiometric chamber.

Technician Certification

NAVMEDCOMINST 6260.5 requires that hearing tests be performed by trained and certified technicians. This certification is obtained by attending a standardized course of instruction conducted by or authorized by the NAVENVIRHLTHCEN. Recertification is required every three years. Additionally, all hearing tests must be under the supervision of an audiologist or a qualified physician.

Audiometer Calibration

Calibration of audiometric equipment consists of two elements - the daily biological calibration

and listening check and the annual "physical" calibration. Both are required by NAVMED-COMINST 6260.5.

Daily biological calibration checks are an essential element of successful HCPs. This check consists of comparing hearing thresholds of a known individual or an electroacoustic test device with previous baseline audiograms on each audiometer. If the hearing thresholds are five dB or less different from the baseline, the audiometer is considered to be functioning properly. If this procedure is not done daily, audiograms performed for lengthy periods may be inaccurate. A daily entry on a DD 2217 form is required to document the biological calibration check. Annual physical calibration and preventive maintenance is performed by NAVENVIRHLTHCEN. This service is free to all activities and is covered by NAVMEDCOMINST 6700.35B. Any questions concerning audiometer repair should be directed to the Medical Treatment Facility biomedical repair service or NAVENVIRHLTHCEN.

Audiometric Booth Certification

The audiometric chamber on "booth" at shore facilities must be certified every two years. Audiometric booths aboard ship require certification annually. This certification should be requested from the local occupational health service or the NAVENPVNTMEDU. Required levels for ambient noise during testing are found in Appendix A of NAVMEDCOMINST 6260.5.

If the booth meets the required levels, the certification should be posted on the booth. If the booth fails certification, maintenance, relocation, or procurement of another booth may be necessary.

If the booth meets the required levels, the certification should be posted on the booth. If the booth fails certification, maintenance, relocation, or procurement of another booth may be necessary.

Audiometer Types

There are three basic types of audiometers used in HCPs - manual, self-recording, and microprocessor controlled. Each type of audiometer may be best suited for a particular situation and selection should be based upon a number of variables. The manual audiometer allows the technician to control the test and obtain thresholds directly. This may be desirable in testing for some individuals. Manual audiometry would not be the audiometer of choice in situations where procedures may become rushed or where supervision of testing is inadequate.

Otorhinolaryngology

Microprocessor controlled audiometers are programmed to test hearing in a preset manner. Error traps are built in to detect problems or test errors. This type of audiometer may be set up as a group audiometer system, allowing one technician to monitor several hearing tests at the same time. Considering the large numbers of people who need annual monitoring, group audiometry may be the only adequate solution to the problem.

Self-recording audiometry is not recommended. Experience with this type of equipment has shown it to be prone to tester or patient error. If this equipment is used, NAVMEDCOMINST 6260.5 requires the following criteria be met:

1. It must be possible to draw a straight line through the center of the tracing at each frequency such that it deviates no more than five dB from the beginning to the end of the tracing for that frequency.
2. The tracing shall cross the line drawn through the center at least eight times at each test frequency.
3. A 10 dB validity check must be done within the frequency range of 1,000 - 3,000 Hz for each ear and, at the discretion of the technician, whenever a rhythmic response is suspected.

NAVMEDCOMINST 6260.5 notes that when a self-recording audiometer test fails to meet the above criteria, a manual or microprocessor controlled test must be administered. Additionally, group audiometry using self-recording audiometers is restricted to no more than four test stations per technician.

Audiometry performed for HCPs

The purpose of performing audiometry on personnel exposed to noise is to detect problems before individuals suffer hearing loss sufficient to cause communication problems. This is done by establishing a baseline or reference audiogram (recorded on a DD 2215 form) prior to noise exposure and comparing future monitoring audiograms (recorded on a DD 2216 form) against this reference. Audiograms obtained at Military Examination Processing Station (MEPS) are not allowed to be used as reference audiograms.

Many branch clinics and physical exam sections conduct audiometry for both HCPs and for physical exams. The requirements for HCP audiometry are not mandated for physical exam hearing tests. Hearing tests that meet all the requirements for HCP may be used for physical exam purposes but not the reverse. Care should be taken to avoid unnecessary duplication of hearing tests.

Hearing Protective Devices

Manufacturers Nomenclature	Type of Protector	Federal Nomenclature	NSN	Cost
Ear Defender V-51 R	Insert Earplug (sized)	Plug, Ear, Noise Protection 24's (X-Small) (White)	6515-00-442-4765	.81 pk
		24's (Small) (Green)	6515-00-467-0085	.84 pk
		24's (Medium) (Int. Orange)	6515-00-467-0089	.86 pk
		24's (Large) (Blue)	6515-00-442-4807	.86 pk
		24's (X-Large) (Red)	6515-00-442-4813	1.15 pk
Comfit, Triple Flange	Insert Earplug (sized)	Plug, Ear, Noise Protection 24's (Small) (Green)	6515-00-442-4821	3.03 pk
		24's (Medium) (Int. Orange)	6515-00-442-4818	2.84 pk
		24's (Large) (Blue)	6515-00-467-0092	2.48 pk
Silaflex (Blister Pack)	Non-Hardening Silicone	Plug, Ear, Hearing Protection Cylindrical, Disposable 200's	6515-00-133-5416	7.73 pk
E A R or Decidamp	Foam Plastic Insert	Plug, Ear, Hearing Protection Universal Size, Yellow 200 Pair	6515-00-137-6345	17.78 200 pr
Sound-Ban	Headband, Earcaps	Plug, Ear, Hearing Protection Universal Size	6515-00-392-0726	3.15 ea.
Straightaway Muffs ("Mickey Mouse" ear muff)	Circumaural Muffs	Aural Protector, Sound 372-9AN/2	4240-00-759-3290	5.65 ea.
		Replacement Filter, Dome Replacement Seal, Dome	4240-00-674-5379 4240-00-979-4040	.27 ea. 1.06 pr
Ear Plug Cases	Type I Overhead Headband, Circumaural Muff	Case, Earplug 12's	6515-00-299-8287	.20 ea
Earscope Earplug Gauge		Gauge, Earplug	6515-00-117-8552	1.92 pr.
Open to Lowest Bidder	Type II Napeband Circumaural Muff for use with Hard Hat	Aural Protector, Sound	4240-00-691-5617	2.90 ea.
Open to Lowest Bidder		Aural Protector, Sound	4240-00-022-2946	4.42 ea.

98-8

Table 8-12

Hearing Protective Devices

Hearing Protective Devices

The purpose of hearing protective devices is to reduce noise exposure to safe levels. OP-NAVINST 5100.23B requires the hearing protector to reduce the noise to a level below 84 dB(A). There may be situations where this is not possible. In those cases exposure must be limited by administratively controlling exposure time. Most individuals, however, can be protected by either ear plugs, ear muffs or a combination of both.

Basically, hearing protective devices attenuate or reduce the amount of noise reaching the ear by placing a barrier of materials either in or around the ear. In order to be effective, these materials must produce an airtight seal. These materials also must be relatively flexible and non-toxic. Finally, they must be as comfortable as possible. A listing of currently approved hearing protectors is provided in Table 8-12.

Muffs are safety items, hence, they carry the 4240-series stock designation. Plugs are medical items; they have the 6515-series designation. Note that there is now a 13-digit stock number for the NSN system. Older stock numbers containing only 11 digits will be rejected by the supply system computers.

REFERENCES AND BIBLIOGRAPHY

- American National Standards Institute. Specification for audiometers (ANSI S3.6-1969). New York: American National Standards institute, 1969.
- American National Standards Institute. Criteria for permissible maximum ambient noise during audiometric testing (ANSI 53.1- 1977). New York: American National Standards Institute Inc., 1977.
- American Standards Association. Specification for audiometers (ASA Z24-5-1951). New York: American Standards Association, 1951.
- Ballinger, J.J. *Diseases of the nose, throat and ear*. Philadelphia: Lea & Febiger, 1969.
- Boles, L.R., Hilger, J.A., & Priest, R.E. *Fundamental of otolaryngology*. Philadelphia: W.B. Saunders, 1964.
- Brunt, M.A. Chapter 14, In Katz, J. (Ed.), *Handbook of clinical audiology*. Baltimore: Williams & Wilkins, 1985.
- Hawthorne, T.A., & Hewlett, A.B. Meneire disease. *Proceedings of the Royal Society of Medicine*, 1954, 47, 663-670.
- Davis, H., & Silverman, S.R. *Hearing and deafness* (3rd ed.). New York: Rinehart and Winston, 1970.
- Department of the Navy, Bureau of Medicine and Surgery. Hearing conservation program (BUMEDINST 6260.6B).
- Department of the Navy, Bureau of Medicine and Surgery. *Manual of the Medical Department*, U.S. Navy (NAVMED 117).
- Department of the Navy, Bureau of Medicine and Surgery. Repair and calibration of audiometric equipment (BUMEDINST 6700.35).

U.S. Naval Flight Surgeon's Manual

- Department of the Navy, Office of the Chief of Naval Operations. The Department of the Navy Safety Program; implementation of (OPNAVINST 5100.8C). 8 September 1975.
- DeWeese, D.D., & Saunders, W.H. *Textbook of otolaryngology*. St. Louis: C.V. Mosby, 1973.
- Fletcher, H., & Munson, W.A. Loudness, its definition, measurement and calculation. *Journal of the Acoustical Society of America*, 1933, 5, 82-108.
- Hirsh, I.J. *The measurement of hearing*. New York: McGraw- Hill, 1952.
- Hochberg, I. Interpretation of audiometric results. In H. Halpem (Ed). *Bobbs-Merrill studies in communicative disorders*. Indianapolis and New York: Bobbs-Merrill, 1973
- Hollinshead, W.H. *Anatomy for surgeons: (Vol. 1) Head and neck*. New York: Harper, 1961.
- Impedance audiometers. *Instruction manual*. Dobbs Ferry, New York: Electromedics, 1976.
- International Organization for Standardization. Standard reference zero for the calibration of pure tone audiometers (ISO/R 389-1964). Geneva, Switzerland: International Organization for Standardization, 1964.
- Jerger, J. Hearing tests in otologic diagnosis. *American Speech and Hearing Association (ASHA)*, 1962.4, 139-142.
- Jerger, J. (Ed). *Modern developments in audiology* (3rd ed.). New York: Academic Press, 1983.
- Jerger, J. Bekesy audiometry in analysis of auditory disorders. *Journal of Speech and Hearing Research*, 1960, 3, 275-289.
- Johnson, E.W. Auditory findings in 200 cases of acoustic neuromas. *Archives of Otolaryngology* (Chicago), 1968, 88, 598603.
- Katz, J. (Ed.). *Handbook of clinical audiology* (3rd ed.) Baltimore: Williams and Wilkins 1985.
- Maloney, W.H. (Ed.). *Otolaryngology* (5 vols.). New York: Harper & Rowe, 1974.
- Moffitt, O.P., Jr., Left, J.E. & Tonndorf, J. *Aviation otolaryngology*. Brooks Air Force Base, Texas: U.S.A.F. School of Aerospace Medicine, 1956.
- Newby, H. *Audiology* (4th ed.). New York: Appleton- Century-Crofts, Inc., 1985.
- O'Neill, J.J., & Oyer, H.J. *Applied audiometry*. New York: Dodd, Mead and Co., 1966.
- Peterson, A.P.G., & Gross, E.E., Jr. *Handbook of noise measurement* (7th ed.). Concord, MA: GenRad, 1972.
- Rose, D.E. (Ed.). *Audiological assessment*. Englewood Cliffs, New Jersey: Prentice Hall, 1971.
- Sataloff, J. *Hearing loss*. Philadelphia and Toronto: J.B. Lippincott, 1966.
- Saunders, W.H., & Paparella, M.M. *Atlas of ear surgery*. St. Louis: C.V. Mosby, 1968.
- Saunders, W.H., & Gargier, R.W. *Pharmacotherapy in otolaryngology*. St. Louis: C.V. Mosby, 1976.
- Secretary of the Navy. Accident prevention, safety, and occupational health policy; implementation of (SECNAVINST 5100.10C). 21 October 1976.
- Shea, J.J., & Bowers, R.E. Fluctuating hearing loss. *Otolaryngologic Clinics of North America*, 1975, 8, 421-4438.
- Spector, M. (Ed.). *Dizziness and vertigo: Diagnosis and treatment*. New York: Grune & Stratton, 1967.
- Toglia, J.U. Neurological examinations and symptoms suggesting neurological checkup. In M. Spector (Ed.), *Dizziness and vertigo: Diagnosis and treatment*. New York: Grune & Stratton, 1967.
- Williams, H.L. Medical treatment: The episodic vertigo. In M. Spector (Ed.), *Dizziness and vertigo: Diagnosis and treatment*. New York: Grune & Stratton, 1967.

Otorhinolaryngology

U.S. Naval Flight Surgeon's Manual. Prepared by BioTechnology, Inc., under Contract Nonr-4613(00).
Chief of Naval Operations and Bureau of Medicine and Surgery. Washington, D.C., 1968, 1978.

APPENDIX 8-A

MODEL INSTRUCTION FOR ESTABLISHING A NOISE CONTROL
AND HEARING CONSERVATION PROGRAM

The following model instruction, based on one prepared by Commander, Training Air Wing Six, NAS Pensacola, describes the steps in establishing an effective HCP program. This instruction should be modified to meet the specific needs of individual commands.

(COMMAND) INSTRUCTION...

Subj: Noise Control and Hearing Conservation Program

Ref: (a) SECNAVINST 5100.10C (NOTAL)
(b) OPNAVINST 5100.14
(c) BUMEDINST 6260.6B
(d) NAVAEROSPREGMEDCENINST 6260.1

1. *Purpose.* To establish procedures for the implementation of an effective noise control and hearing conservation program. The basic objectives are to control noise emissions where technically feasible and to prevent hearing loss in personnel exposed to potentially hazardous noise sources.

2. *Scope.* This instruction applies to all activities within (Activity) having designated noise hazard areas and equipment.

3. *Background.* The policy of the Secretary of the Navy, stated in references (a) and (b) emphasizes that accident prevention, safety, and occupational health are inherent responsibilities of command. Work place noise control and hearing conservation programs are important aspects of this overall responsibility. Where noise control is not economically feasible, a medically-oriented hearing conservation program, outlined in references (c) and (d) becomes necessary as a feasible interim solution.

4. *Responsibility.*

a. Commanding Officers of (Activity) are responsible for keeping abreast of all noise hazard areas and equipment and shall institute noise control measures where feasible. Additionally, they shall ensure that all noise hazard areas and equipment are labeled with NAVMED 6260/2, Hazar-

Otorhinolaryngology

dous Noise Warning Decal, and NAVMED 6260/1A, Hazardous Noise Labels (displayed on hand tools), as appropriate.

b. As directed by reference (c), Industrial Hygiene personnel in coordination with Safety Department personnel are requested to perform the necessary noise surveys to identify both the noise hazard areas and equipment and also all noise-exposed personnel.

c. The Aerospace Physiologist assigned as Aeromedical Aviation Medical Safety Officer (AMSO) in conjunction with the Flight Surgeon shall be responsible for coordinating and monitoring the hearing conservation program. He shall also provide educational and training services as required.

d. The Safety Officer and the AMSO team member shall be responsible for conducting inspections of all activities for compliance with this instruction during administrative personnel inspections.

e. The flight surgeon or Medical Officer shall evaluate all hearing loss cases in personnel detected by monitoring audiometry as required in reference (c).

f. All supervisors shall be responsible for monitoring the use of hearing protection by their noise-exposed personnel and help coordinate the periodic hearing testing as required in reference (c). They shall set an example in the wearing of ear protection and initiate disciplinary measures for failure to comply with this instruction.

5. *Action.*

a. The use of approved hearing protection (ear plugs, ear caps, or muffs) in designated noise hazard areas shall be mandatory during periods of excessive noise. Double protection (plugs and muffs) will be required during high power turn-ups exceeding five minutes.

b. All personnel assigned to duties within or around designated noise hazard areas and equipment shall:

- (1) Have a baseline or reference audiogram in their health record.
- (2) Have a monitoring audiogram within three months after assignment.
- (3) Have an annual monitoring audiogram thereafter unless the Flight Surgeon determines that a shorter interval is required.

U.S. Naval Flight Surgeon's Manual

(4) Be fitted with a set of approved ear plugs by trained medical personnel.

c. Approved ear muffs will be used around all operating aircraft. Flight and transient personnel may utilize approved ear caps during preflight inspections or short duration exposures (less than 15 minutes). Ear muffs and ear caps shall be furnished by individual commands.

d. Personnel who refuse periodic hearing testing or refuse to utilize hearing protection while in designated noise hazard areas will be subject to appropriate disciplinary action.

e. All personnel shall be educated in the hazards of exposure to noise on at least a semi-annual basis.

f. Recommendations by the flight surgeon or other qualified medical officer for the removal of individuals from further noise exposure shall be given command attention.

g. Activities shall submit semi-annually a list of all personnel assigned to designated noise hazard areas to the AMSO team member with a copy to the Branch Clinic. The AMSO team member shall help coordinate the workload and timely testing of all noise-exposed personnel.

h. Activities shall maintain records on personnel who work in noise hazard areas, showing date of most recent monitoring audiogram.

CHAPTER 9

OPHTHALMOLOGY

Introduction

General Ophthalmology

Refraction and Lenses

Trauma and Ophthalmologic Emergencies

Sudden Disturbances of Visual Acuity

Glaucoma

Annual Physical Examinations on Flight Personnel

Eyewear for Navy Personnel

Perceptual Disorders

Topics of Interest for Safety Lectures

Bibliography

Introduction

The purpose of this chapter is to convey useful information about ophthalmological problems pertaining to the naval aviator. References do not answer the questions, "Is he safe to fly?" or "When can he fly?" The answers to these questions are best determined from practical experience and from knowledge common to the flight surgeon, ophthalmologist, and optometrist.

The flight surgeon is encouraged to obtain consultation and advice from ophthalmologists and optometrists when it is indicated. However, it has been observed that the flight surgeon can take care of most problems related to the eyes and visual parameters as applied to the flight safety of the naval aviator.

General Ophthalmology

The following areas are recommended for an orderly and complete examination by the flight surgeon:

1. Lids and adnexa (lacrimal apparatus and caruncle)
2. Conjunctiva and cornea

3. Sclera
4. Pupil and its reactions
5. Slit lamp exam of anterior chamber (if available)
6. Funduscopy exam
7. Extraocular motility
8. Visual fields
9. Intraocular tension when indicated.

A brief discussion of abnormalities that the flight surgeon will see, and the recommended management, follow.

Lids and Adnexa

Styes and chalazions are the most frequent causes of complaints. Treatment should consist of grounding for severe cases, hot wet compresses, and instillation and/or lid scrubs with a topical broad spectrum antibiotic such as Erythromycin, Tobrex, or Garamycin drops or ointment. Most styes will drain or absorb with this treatment in 5 to 10 days. If "pointing" they may be incised.

Chalazions should be treated the same way. If they persist for four to six weeks they usually will need to be injected with a Depo Steroid - Kenalog or Aristocort. A few will require incision and curettage. Also they sometimes cause decreased visual acuity by pressing on the globe and causing astigmatism.

Epiphora indicates excessive tear production or a blockage of the nasolacrimal drainage system. Usually epiphora is due to a temporary blockage either caused by a nasal allergy or secondary to a dacryocystitis. Appropriate treatment should be rendered and the epiphora will subside.

Conjunctiva

Infections of the conjunctiva are common, and usually are self-limited diseases lasting 10 to 14 days. Recommended treatment is personal hygiene, warm compresses, and frequent (q 3 to 4 hours) instillation of a broad spectrum antibiotic or sulfa. Do not use steroids unless indicated. Usually the pilot should be grounded.

Pinguecula and pterygia can be treated with topical decongestants and/or lubricants (artificial tears or ointments) for minor inflammations. They should be referred to an ophthalmologist when indicated. Surgical removal of a pterygium usually means grounding for at least four weeks. The squadron should be in a position to allow for this grounding before the surgery is performed.

Ophthalmology

Sclera

Diseases of the sclera are usually mildly inflammatory and best treated with topical steroid drops.

Pupil

Acquired disorders of the pupil result in the involved pupil being larger or smaller than normal. Larger pupils may result from contamination with cycloplegic drops. This is fairly common in medical department personnel who work around these drugs. Other causes are Adie's tonic pupil and head trauma. Optic neuritis can also cause a unilateral enlarged pupil with diminution of direct light reflex - known as Marcus Gunn pupil. These cases should be evaluated thoroughly.

Causes of smaller pupils are drug usage (narcotics) and contamination with miotics such as pilocarpine. Horner's syndrome also causes miosis on the involved side.

Slit Lamp Exam (if available)

Iritis is best diagnosed by using a slit lamp to see cells and flare in the anterior chamber. Treatment is to dilate the pupil with long-acting cycloplegics such as scopolamine, homatropine or atropine to prevent posterior synechia, and the topical administration of a steroid to minimize the inflammation. Iritis typically last three to four weeks. The flyer should be grounded during this time. An ophthalmological consultation should be obtained. Recurrent uveitis causes so much down time for an aviator that separation from flying is sometimes recommended.

Fundusoscopic Exam

Fundus diseases of the young healthy aviator are uncommon and will usually fall either into a group of disorders known as "central serous retinopathies" or posterior chorioretinitis. In the former, diagnosis can be made by careful exam with an ophthalmoscope, noting a loss of the foveal reflex and edema of the macula.

Posterior chorioretinitis can be recognized by vitreous debris and the presence of a fresh chorioretinal lesion. Most cases will be due to either toxoplasmosis or histoplasmosis. Management by an ophthalmologist is necessary. After healing, if the macula is not involved, flying can be resumed.

Extraocular Motility

If any of the phorias exceed acceptable standards, referral to an eye professional for complete evaluation is required.

Visual Fields

A well-performed confrontation visual field is all that the flight surgeon need do. If it is abnormal, then further testing by tangent screen and/or perimeter is indicated. The flight surgeon who doesn't know how to perform a confrontation visual field must ask someone who does, or consult the *Manual of the Medical Department* (MANMED)

Intraocular Tension

The determination of the intraocular pressure is recommended annually for all individuals 40 years of age or over. The intraocular pressure should also be determined whenever clinically indicated such as through findings of an enlarged optic cup or history of an elevated intraocular pressure on previous occasions.

Refraction and Lenses

The naval flight surgeon will be called on to evaluate refractive errors, especially in naval flight officers (NFO's), and in older aviators. He can usually, if he chooses, refer these personnel to an eye professional for the appropriate refraction. However, it is still the flight surgeon's responsibility to ensure that the aviator is in the correct service group and that corrective lenses are prescribed and that they are appropriate.

Remember that all flight personnel and deck crew who wear glasses should have at least two pairs of corrective lenses. Obviously, if the only pair of glasses is misplaced or damaged, then the person is incapable of performing his duties safely until new glasses are obtained. It is the medical department's responsibility to ensure that these individuals do have an extra pair of corrective lenses.

The only authorized lenses for flight personnel are the FG (Flight goggle)-58, either in clear lenses or sunglasses.

Pilots and NFO's should not be allowed to wear polarized glasses. Canopies and windscreens may also have a polarizing effect which can result in "scotomas," a very hazardous condition.

Ophthalmology

Pilots also should be advised against wearing the photosensitive type of sunglasses because they do not offer enough protection from sunlight. These lenses contain chromium and change to a darker color when exposed to sunlight; however, the tint is not sufficiently dense to filter out enough of the rays of light to protect the retina from glare, and they may have little or no ultraviolet screening effect.

If a cycloplegic refraction is performed on aviation personnel, they should be advised that it will be necessary for them to be grounded from 24 to 48 hours. They must be examined prior to flying again, and their pupils and accommodation must have returned to normal limits.

The flight surgeon must remember that many aviators might have small visual defects which should be corrected with lenses, but due to fear of being grounded or being placed in another service group, they will continue to squint and have less than optimum visual acuity. The flight surgeon is encouraged to instill confidence in these people - to reassure them that he or she is there to help them and make them safer pilots - not to ground them or to change their service groups.

The Dissatisfied Refraction Patient

A certain percentage of patients who obtain new spectacles will have some complaint. Many times this is due to small changes in the new prescription and the fact that the patient has not worn the spectacles long enough to get used to them. Spectacles with more plus lenses frequently take several days of wear before they are accepted.

To verify that the prescription of a patient's spectacles is the same as that which was ordered, one should take the following steps:

1. Lensometer reading on the new spectacles. These readings usually reveal the prescription to be correct. Only a small percentage of errors are made in filling prescriptions. Acceptable tolerances from the optical laboratory, which will cause no problems and should be accepted as optically correct, are listed below:

- a. The sphere power can vary as much as .12 diopters on either side of what was ordered.
- b. The cylindrical power can vary as much as .12 diopters on either side.
- c. The cylindrical axis can vary as much as five degrees on cylinders of 1.00 diopter or less; for larger cylinders the axis variance should be three degrees or less.
- d. The optical centers should be within 1 to 2 millimeters (mm) of the measured inter-pupillary distance (IPD).

2. Distance between the optical centers should be checked. This should be within 1 to 2 mm of the IPD. If off by more than 2 mm, this could conceivably cause prismatic problems. If the optical centers are found to be off, and this is felt to be the problem, another pair of spectacles must be ordered.

3. If steps (1) and (2) are found to be correct, then a repeat refraction is indicated to rule out an error. The most common error is one of prescribing too much minus sphere or not enough plus sphere. Next is prescription of a new cylinder correction which, although optically correct is symptomatically intolerable to the patient. Solution: cut the (minus) cylinder in half, and increase the minus sphere power half of that.

The above steps will determine whether or not a patient's complaints are caused by optical problems. If the patient does have what was ordered and the refraction is correct, and yet the patient continues to have symptoms, then it would be appropriate to have him evaluated by someone else. However, it is not uncommon for the ophthalmology consultant to find that the examining flight surgeon was correct in his refraction.

A small error in a refraction resulting in a naval aviator wearing spectacles which are not exactly perfect will in no way cause harm to his eyes, nor should this small error result in a dangerous flight situation, as long as the visual acuity is 20/20.

Trauma and Ophthalmologic Emergencies

Abrasions and Foreign Bodies

Minor trauma to and about the globe usually results in superficial corneal abrasions. A corneal abrasion can easily be diagnosed by using a strip of fluorescein to stain the cornea with or without some topical anesthetic. When the excess is washed, the area of denuded cornea will show up as a yellowish green area, especially when illuminated with a Cobalt blue light. Treatment of superficial corneal abrasions consists of patching the eye for 12 to 24 hours after instilling a broad spectrum antibiotic. The purpose of the patch is to keep the eyelids from blinking and rubbing the cornea. The patch should be tight enough to prevent this and usually require 6 to 8 pieces of tape. Healing of the defect occurs by sliding of new epithelium from the conjunctiva and by mitosis. Most abrasions heal within 12 to 24 hours. Remove the patch the following day and examine the patient. If the defect is almost healed, then broad spectrum antibiotic drops should be used for five to six days.

When a corneal foreign body is encountered it usually can be removed easily. The patient should lie on his back and be made comfortable. Instill anesthetic drops into the involved eye,

Ophthalmology

and have the patient fixate an overhead target with the noninvolved eye. In many cases the foreign body may be touched with a sterile applicator stick and this will dislodge it. If the foreign body is embedded, a sterile 20 gauge needle or other sterile instrument, such as a spud or dental burr may be used. The foreign body may be lifted out by the point of the instrument. A broad spectrum antibiotic ointment should be instilled and the eye patched for 24 hours. Topical antibiotic drops should be applied for three to five days. A rust ring, if present, indicates ferrous material and oxidation; the rust ring should be removed with the foreign body, but if it cannot be removed, the eye should be patched and the remainder of the rust ring removed the following day. A small rust ring will absorb over a period of days.

Most abrasions and foreign body sites will heal with no further problems. Treatment is used to prevent the rare case of infection leading to a corneal ulcer.

Lid-Skin Lacerations

Lacerations of the lid and the skin of the eyelids should be cleaned and primarily repaired with small interrupted sutures such as 5-6 0 silk or nylon. The flight surgeon can confidently close most lacerations involving all but the margin of the lid. If the laceration involves the lid margin, and the services of an ophthalmologist are available, the eye should be patched and the patient referred to the ophthalmologist. If the flight surgeon has to do the primary repair, the edges should be approximated as closely as possible and small sutures used. Due to the good vascular supply and the elasticity of the lids, lacerations heal quickly. The sutures should be removed on the fourth to fifth postoperative day.

Canaliculus

If a laceration through the upper or lower canaliculus is noted, it is recommended that the patient be referred to an ophthalmologist for repair. If no ophthalmologist is available, an attempt should be made to insert a small polyethylene catheter or a small silk suture through the severed ends of the canaliculus. The skin and lid margins should then be closed on either side with interrupted sutures. The catheter must be left in place for a minimum of four weeks.

Hyphema

Blunt trauma to the globe sometimes results in hyphema. This can easily be diagnosed by gross blood in the anterior chamber. The blood usually comes from the iris or ciliary body. This blood will absorb in two to three days if a re-bleed does not occur. The recommended treatment to prevent a re-bleed is complete bedrest with patching, cycloplegia, and sedatives until the gross blood

has absorbed. If an ophthalmologist is available, the patient should be referred to the ophthalmology services for admission to the hospital. If he is an aviator or naval flight officer (NFO), he should be grounded for approximately two weeks *after* the blood has absorbed. Re-bleeds do occur in 10 to 15 percent of the cases regardless of the treatment. Treatment of the re-bleed is continued patching and bedrest. If the re-bleed is of such degree as to raise the intraocular pressure and cause blood staining of the cornea, it is a serious ophthalmological problem. If a re-bleed is encountered, it is strongly recommended that ophthalmological consultation be sought.

Fracture of the Orbit

X-rays of the orbits should be obtained to rule out fractures when moderate or severe trauma in and about the orbit is encountered. Many times the patient may be asymptomatic, but the X-ray will reveal evidence of fracture of the orbital area, either a "tripod" or a pure "blowout" of the orbital floor. This is usually seen as a clouding of the involved antrum which indicates either hemorrhage or herniation of the orbital contents and floor into the antrum. Another common finding with fracture of the floor of the orbit is diplopia and restriction of that eye on attempted evaluation. These problems should be referred to an ophthalmologist. If conditions prevent this, it is recommended that the patient be treated symptomatically with tetanus toxoid and broad spectrum antibiotics and cold compresses as indicated. Use warm compresses if infection is present. The patient may be referred to an ophthalmologist when the occasion arises, but in no case may the fracture be ignored. Serious deformity may result in the future.

Laceration of the Cornea and/or Globe

When the cornea or globe has been lacerated, the recommended treatment is to *lightly* patch both eyes, cover the lacerated eye with a Fox metal shield to insure no pressure is applied to the eye, and place the patient on his back. Medicine should *not* be instilled into the eye. The patient should be evacuated to a hospital where ophthalmic services are available for repair. If an ophthalmologist is not available, it is recommended that the patient continue to be treated supportively until evacuation can be accomplished. (Administer tetanus toxoid and broad spectrum antibiotics.) Primary closure of corneal wounds has been performed as long as 36 to 48 hours after the initial injury with good results. In very unusual circumstances of isolation, the cornea can be sutured by anyone with the smallest suture available (7-0 silk?).

Chemicals in the Eye

Any chemical in the eye should be considered an emergency. Most chemicals in the form of solutions or powders are very irritating and toxic to the eye. The eye should be irrigated at once.

Ophthalmology

The best source of an irrigating solution is a sterile IV bottle of normal saline. The tubing should be used to meter the flow. The patient should be placed on his back and topical anesthetic instilled into the eye; then a Corpsman should slowly irrigate the eye with the sterile solution for 15 to 20 minutes. Then the eye should be examined and the irrigation continued for another 15 minutes if a very caustic chemical was involved. The prognosis for most acid burns is good, for alkali, poor. Antibiotic drops containing steroids are indicated for chemical burns to the cornea and conjunctiva.

Sudden Disturbances of Visual Acuity

Fortunately, sudden loss of visual acuity is relatively rare. These disturbances occur more often in the older age groups and are associated with hypertensive, arteriosclerotic, and diabetic changes in the circulatory systems. A brief discussion of the more common causes follows.

Occlusion of the Central Retinal Artery

Occlusion of the central retinal artery or one of its branches which supplies the macular region will result in almost immediate diminution or loss of visual acuity in the involved eye. In young adults the etiology is usually an embolus or spastic occlusion of the central retinal artery or one of its branches.

Total occlusion of the central retinal artery or a branch can be diagnosed by observing the fundus and noting a pale area distal to the occlusion. Treatment is aimed at vasodilatation and ocular massage. If an ophthalmologist is available, ocular paracentesis (to abruptly lower the intraocular pressure) and/or retrobulbar injection of priscoline in a mixture of xylocaine without epinephrine may be used. The use of Carbogen (a mixture of oxygen and carbon dioxide) for vasodilation has been recommended; in a pinch, the old paper bag rebreathing trick may help.

In general the treatment that can be administered by the flight surgeon is very little. If the occlusion of a central retinal artery or its branch is total and it persists for more than five minutes, it is unlikely that the involved retina will recover.

The term amaurosis fugax has been used to describe fleeting vision. This condition results when moderate to severe arteriosclerotic narrowing of the internal carotid artery exists, causing lowered blood pressure to the ophthalmic artery. The patient describes gradual loss of visual acuity which persists for two to three minutes, then a gradual return of visual acuity. The hypoxia causes no lasting damage and visual acuity usually returns to preoccurrence levels. When one suspects amaurosis fugax, determination of the central retinal artery pressure by ophthalmodynamometry

is indicated. The prognosis is poor; many of these patients suffer strokes within months of the onset of symptoms unless treated.

Occlusion of the Central Retinal Vein

Symptoms of occlusion of the central retinal vein or one of its branches is much less sudden in onset than occlusion of the artery. The loss of vision is due to edema or hemorrhage. Causes of occlusion of the central retinal vein are diabetes mellitus, glaucoma, periphlebitis, and compression of the vein at the AV crossing by arteriosclerotic processes. Usually the percentage of recovery from vein occlusions is much better than arterial occlusions. The flight surgeon should make the diagnosis by noting scattered hemorrhages throughout the fundus associated with a dilated venous segment. This is not a real emergency. The patient should be referred to an internist or an ophthalmologist for a complete medical and eye workup. Specific treatment is controversial.

Vitreous Hemorrhage

Vitreous hemorrhage is most common after trauma or rupture of a neovascular tuft in the eye. The predominant cause of neovascularization is diabetes mellitus. The diagnosis is obvious when viewing the fundus. It is noted that the vitreous is hazy with RBC's or contains gross hemorrhage. Treatment should be bedrest until the bleeding ceases and consultation with an ophthalmologist. The visual acuity will depend on the extent of the hemorrhage within the visual axis.

Optic Neuritis

Optic neuritis frequently produces a rather sudden loss of central visual acuity. The patient may have had a "viral-type illness" with headache and fever for several days previously. However visual loss without antecedent symptoms is also frequent. There may be some retrobulbar pain on motion of the eye. Visual acuity is usually diminished anywhere from 20/200 to 20/40 or 20/50. Funduscopic examination may reveal a completely normal optic disc, especially in retrobulbar optic neuritis. ("The patient sees nothing; the doctor sees nothing.") In papillitis the disc is hyperemic but not elevated. In visual field examination the blind spot is of normal size but a central scotoma will be present. Clues that are important in helping to make this diagnosis are a Marcus Gunn pupil, one which shows a reduced amount of reaction to direct light, and disturbed red-green color perception in the involved eye. This color disturbance can be determined by testing color vision monocularly.

Treatment in the early phases is usually with systemic steroids on the order of 50 to 80 milligrams (mg) of prednisone daily. This should be continued for 7 to 10 days while following the

Ophthalmology

visual acuity of the patient. The most likely cause of optic neuritis is multiple sclerosis. If this is the cause, visual acuity usually will start improving within 3 to 4 days and many times will return to a normal 20/20. Other causes of optic neuritis are toxins and infections from adjacent tissues.

Central Serous Retinopathies

Edema and hemorrhage into the retina or subretinal area in the macular region describe syndromes known as "central serous retinopathy." These syndromes are ill-defined and have diverse etiology, but are fairly frequently seen by the ophthalmologist. The patient is usually a young adult, "Type A" under a stressful situation. Diagnosis can be made by the symptoms of decreased visual acuity on the order of 20/40 to 20/50. Associated with this is metamorphopsia (alteration in shape of objects). Careful fundoscopic examination will reveal minimal edema and/or hemorrhage and loss of the foveal reflex in the involved eye. The cause of this is thought to be an autonomic nervous system imbalance causing vasodilatation and increased permeability of the vessels in the macular region.

If hemorrhage is present, systemic steroids are commonly used. In the absence of hemorrhage, steroids are usually not recommended because the course of the disease seems to be unaltered either way. It is also recommended that vasoconstrictors such as nicotine, coffee, and tea be avoided. Also, strenuous exercise should be avoided. Further, consideration should be given to removing the patient from any environment or occupation causing unusual stress. Reassurance can be offered because visual acuity will return to 20/20 in a large percentage of the cases. This condition lasts an average of four to eight weeks.

Glaucoma

Because approximately 2 1/2 percent of the adult population has chronic open angle glaucoma (C.O.A.G.), the flight surgeon will probably have one or more people in his squadron who are under treatment for this affliction. This will be especially true in the more senior aviators and in older enlisted personnel.

The most common treatment for glaucoma is Timolol or another beta-adrenergic blocker. Some patients need additional drops such as pilocarpine or epinephrine. They should be followed by an ophthalmologist at least every three to four months and have visual fields and accurate study of the optic discs performed at least once annually. As long as the intraocular pressure (IOP) is under control and the visual acuity is corrected to 20/20 and there are no significant visual field defects, aviators can fly in SG- III. If a change to another Service Group is desired, a request for a waiver should be submitted to Naval Aerospace Medical Institute (NAMI).

U.S. Naval Flight Surgeon's Manual

Flight surgeons conducting annual physical examinations should be sure that the IOP is checked in people who are 40 years of age or older or in those whose optic discs show unusually large cups. Patients who have a family history of glaucoma or who have had a previous high IOP finding should have their IOP taken no matter what their age.

The normal IOP range is from 13 to 18 millimeters of mercury. However, it is not uncommon to find IOP's slightly higher than this - ranging from 19 to 23 mm. This degree of IOP usually will cause no damage to the eye. However, an IOP finding greater than 23 mm should be referred to an ophthalmologist for evaluation. This is not an emergency unless the pressure is extremely high. Many eyes will tolerate an IOP of 25 to 30 mm for years without showing any change in the optic disc or the visual field. These people should be followed by an ophthalmologist with careful study.

The trend by ophthalmologists at the present time is to "follow," rather than treat patients with slight elevations of IOP.

Use of the Tonometer

The instrument most readily available to flight surgeons for testing for glaucoma is the Schiøtz tonometer, although many facilities have a noncontact tonometer. The Goldmann applanation tonometer is the most accurate. The Schiøtz is an accurate and fairly simple instrument to use. It is recommended that the squadron or wing flight surgeon assign one or two corpsmen the responsibility for taking the IOP. In addition, these corpsmen should clean the tonometer daily when in use. The recommended method for cleaning the tonometer is to disassemble it and clean the barrel using pipe cleaners soaked in ethyl alcohol or V Mueller 41 solvent which is Freon, and comes in a 4 fl. oz. can with brush (available Cat. OP 9072 American Hospital Supply Corporation). Allow it to dry and then reassemble it. The use of a cotton ball moistened with ethyl alcohol to clean the footplate between patients is recommended. The alcohol must be evaporated prior to use. If an ultraviolet lamp with a tonometer stand is available, it is safe to use. However, a heat sterilizer should not be used; it is a potentially dangerous instrument and some corneas have been burned by injudicious use of a hot tonometer.

Any time an elevated IOP is discovered, the measurement should be repeated on another visit. The most common cause for spurious elevations of IOP readings is faulty technique in taking the pressure.

Acute narrow angle glaucoma is an ophthalmological emergency. This is a rare type of glaucoma in which the iris blocks the anterior chamber angle and causes the IOP to rise to very

Ophthalmology

high levels. A patient with this disease will present with a painful red eye (this is a unilateral condition), a steamy cornea, a fixed semi-dilated pupil, and an IOP between 40 and 60 millimeters of mercury. Primary treatment should consist of installation of two percent pilocarpine every 30 minutes until miosis occurs and perhaps oral or I.V. hyperosmotic agents. This may clear the anterior chamber angle and allow the IOP to return to a normal level. The patient should be referred to an ophthalmologist immediately for further evaluation and probably an elective peripheral iridectomy, either laser or surgical, after the eye has become quiet. The fellow eye should also be studied for need for an elective peripheral iridectomy.

Annual Physical Examinations on Flight Personnel

In performing an annual physical examination on flight personnel and in correctly filling out the Standard Form 88, a flight surgeon will be required to evaluate the general ophthalmological status including external exam, pupillary reactions, and funduscopic exam. In addition, determination of the near and distant visual acuity and tests for stereopsis are required. Also, in individuals who are 40 years of age or older, an intraocular pressure determination must be made. When the near or distant visual acuity is found to be defective, a refraction must be performed which determines whether the visual acuity can be corrected to 20/20, thus ruling out any organic disease. Glasses should be prescribed when indicated by visual standards and when desired by the individual aviator. When any change in Service Group is determined to be necessary because of visual defects, the flight surgeon should counsel the aviator involved and make him or her aware of the change in flight status that is to be recommended. If not sure as to whether or not to recommend a change in Service Group, the flight surgeon should consult with the senior medical officer or call someone more experienced for advice. Changing an aviator's service group because of visual defects that are marginal should be avoided if possible. If the aviator can fly safely with corrective lenses, a waiver or other appropriate action should be taken.

The determination of phorias is not mandatory on an annual basis except for pilots. However, if symptoms of unusual blur or diplopia are present, determination of phorias is indicated. A significant change from previous existing phorias indicates some abnormality in the extraocular muscles and an eye consultation should be obtained.

Color vision determination is not required annually except for pilots but should be performed if symptoms of color deficiency are present. Acquired color defects are rare but do occur.

When the physical exam has been completed, the flight surgeon should ascertain that the visual acuity requirements for the specific service group are met. A Standard Form 88 must not be forwarded to the Bureau with conflicting visual acuity records regarding the recommended service

group. This will result only in the Standard Form 88 being returned for further amplification, (and sometimes a nasty cover letter).

Eyewear for Navy Personnel

The NAVMED instruction 6810.4 series states where and how to order spectacles for eligible personnel. A copy of this is available in medical departments.

At the present time, the appropriate facility issues spectacles to eligible personnel on receipt of a Standard Form DD-771. This form must be properly completed and must have the prescribing practitioner's and the authorizing practitioner's names on the request.

The Navy has two basic types of spectacle frames. One is a brown frame, known as the S-9 frame, and is available to all eligible personnel for correction of refractive errors.

The second type of frame issued by the Navy is the "FG-58 (flying goggle)." This is a gold-coated frame with adjustable nose pads and flat temples. These frames are available only to personnel in a flight status or those who work on the flight deck and are authorized this eyewear by appropriate BUMED instructions. Lenses in the FG-58 goggle can be either clear or tinted. The neutral gray sunglasses filter out approximately 87 percent of the visible light, thus insuring adequate protection against glare causing photophobia, yet allowing enough light for good visual acuity on average daylight days. FG-58s are the only sunglasses authorized for flying.

There are other colored and tinted spectacles on the market which some aviation personnel like to wear but they all have shortcomings compared to the FG-58. The photo sensitive lenses (those containing chromium) change to a darker shade on exposure to light. However, this shade is not dark enough for adequate protection from the sunlight encountered in flying aircraft. Pilots and other flight personnel should be educated on the shortcomings of these glasses and should not be allowed to wear these while flying. They will be subject to glare and photophobia.

Polarized lenses are also occasionally obtained by flight personnel and worn without authorization. The hazards with polarized lenses are great. Occasionally the canopy, windscreen of the aircraft, or visors will have polarizing effects, which, combined with the polarized glasses, will result in scotomas (blindspots) and will be exceedingly dangerous. No flight personnel should be allowed to wear polarized lenses while flying.

All lenses now issued in the S-9 frame are made of plastic; FG 58 lenses are glass but may be ordered in plastic. The cylinders are ground in the minus form, and the fabricating facility will accept the prescription with cylinders written in the minus form. The advantages of the plastic are

Ophthalmology

the light weight and the safety against shattering. The disadvantages of the plastic are that they scratch very easily making the life of the spectacles less than those of glass. Personnel should be educated as to proper care. A set of instructions comes with each issue.

Only personnel on flight orders are eligible for FG-58 frames. It is the flight surgeon's or AMO's responsibility to ensure that only eligible personnel are ordered FG-58 frames. Because the price of gold has "skyrocketed" in the past few years it is doubly important that only eligible personnel receive the flight goggles. The best way to ascertain eligibility is to require a copy of an individual's flight orders prior to ordering the spectacles.

Ametropia In Tactical Aviators

The required use of an oxygen mask in tactical aircraft presents a few extra problems. In addition to fogging and dripping perspiration, there is the fact that the nose contour on the oxygen mask tends to push the frames forward and upward. Some of this can be compensated for by bending the nose pieces on the flight frames outward and/or upward. In cases where there is a high refractive error, say a NFO or RIO, there may be enough displacement of the vertex distance, (the distance from the back of the lens to the cornea) to require a change of lens power - a minus lens must be more powerful as it moves further from the cornea, to focus on the retina, (a plus lens weaker). It may even be necessary to check the power with the aviator wearing his glasses and oxygen mask in an eye lane to see if a change in power is necessary.

Bifocals

Although there aren't large numbers, there are some senior tactical aviators (O6's and up) who are presbyopic and need bifocals. Be sure to get the bifocal placed as low as possible and also, as rule of thumb, give about 1/2 the strength usually needed for the patient's eye, since cockpit instruments are about twice as far away (about 2 1/2 feet) as ordinary reading distances (16").

Contact Lenses

The *Manual of the Medical Department*, Chapter 15, Article 77, authorizes *Class II* aviation personnel to wear contact lenses. A copy of this instruction is available in medical departments.

Briefly, this notice states that Class II aviation personnel (those not in actual control of the aircraft: NFO, FS, etc.) can at their own discretion, wear contact lenses in duties involving flying, provided the contact lenses correct the visual acuity to 20/20, and the individual has on his person an appropriate pair of spectacles as a backup.

Obviously, the wearing of contact lenses will result in a number of corneal abrasions, lost lenses, and incidences of spectacle blur which will cause the individual to seek the aid of a flight surgeon. Information on contact lens problems can be found in the appropriate references. There are three main types of contact lenses, hard (polymethyl methacrylate), semi-rigid gas permeable, and soft.

In general, the problems of the contact lens wearer will fall into one of the following categories. A brief discussion of "how to handle" the problem is listed below:

1. Corneal abrasions.
2. Spectacle blur.
3. Lost or broken contact lenses.
4. Problems with cleaning contact lenses.
5. Other problems with contact lenses.

Corneal Abrasions. These should be suspected when a patient complains of discomfort or a foreign body sensation after wearing the lenses. This problem can best be diagnosed by using fluorescein to stain the cornea. A yellowish-green stain will appear in any area where the epithelium of the cornea is lost or damaged. Treatment is described under abrasions and is aimed at allowing the epithelization process to occur; recent experience with contact lens abrasions seems to discourage patching. The wearing of contact lenses should be discontinued for at least three to five days after total healing has occurred. Wearing time after healing should be gradually increased.

Spectacle Blur. This term refers to the blurring of visual acuity even with corrective spectacles in place after taking out contact lenses. The cause of this is corneal edema and/or a small amount of irregular astigmatism. Usually the best visual acuity obtained by refraction and spectacles is 20/30 or 20/25. The blur persists for one to three days, or until the cornea returns to normal. This blur is common in wearers of rigid contact lenses and most of the time does not cause complaints. However, in the aviation community where 20/20 visual acuity is necessary, it can pose a problem.

Patients who complain of spectacle blur should be refracted immediately after removing their contact lenses. The required correction at this time may be quite different from that necessary several hours later. In some instances certain aviation personnel may require two pairs of spectacles - one to wear for one to two hours immediately after removing the contact lenses, the second pair to wear several hours after the lenses are removed, or first thing in the morning.

Ophthalmology

Spectacle blur is one of the disadvantages of contact lenses, with most wearers experiencing this blur at one time or another. If it becomes increasingly symptomatic, the contact lenses should be checked for adequate fit to insure that "orthokeratology" is not being performed unintentionally. For flight personnel who have this problem in large degree, it is recommended that the flight surgeon encourage them to discontinue their contact lenses and fit them with corrective spectacles after the corneas return to normal.

Lost or Broken Contact Lenses. Most contact lens wearers will at one time or another lose or misplace their lenses or chip one, thus requiring a replacement. These lenses should be replaced only if the patient has a fairly recent prescription with which he is happy and has obtained 20/20 visual acuity. A replacement lens using his prescription could be ordered, but it is necessary that these lenses be purchased through a Navy Exchange with a contract with an optical company. Higher authority has forbidden the individual practitioner to obtain lenses from an individual company on a cash basis.

Problems with Cleaning Contact Lenses. Most contact lens wearers begin by being very conscientious in the hygienic care of their lenses. They follow the recommended procedure for using cleaning and wetting solutions, and in the case of soft and RGP lenses, enzymatic cleaner. However, as time progresses, they take shortcuts and many times this causes oily material and other matter to build up on the surface of the contact lens, especially on soft lenses. This causes the contact lens wearer to experience fluctuating visual acuity as well as other symptoms. The problem can easily be diagnosed by viewing the contact lenses under a magnifying glass or slit lamp. The usual solution to the problem is to reinstitute the daily hygiene originally recommended, however, sometimes soft lenses form "barnacles" which cannot be removed even with a salt slurry, necessitating discarding the lens and ordering a new one. The Navy does not stock cleaning and wetting solutions, and it is up to the individual to procure these from private sources.

Other Problems With Contact Lenses. There are many other problems with contact lenses, some minor and some major enough to require recommendation that the patient cease wearing contact lenses. It is impossible to enumerate all the problems possible, but in general it is recommended that the flight surgeon use common sense in dealing with patients who do wear these lenses. Obviously some myopic NFO's will want to wear contact lenses but due to highly sensitive corneas and tight lids will be unable to wear them except for short periods of time. It is recommended that these people not wear contact lenses. Other patients will wear contact lenses especially soft ones, for a number of months quite successfully, and then for obscure etiologic reasons they develop symptoms of burning, photophobia, and discomfort; a condition called Giant Papillary Conjunctivitis. This is thought to be an acquired sensitivity. After ruling out pathology, if the symptoms persist, it is recommended that these people cease wearing contact lenses.

It is recommended that older people who have had long-standing refractive errors not be fitted with contact lenses. The success rate for these people is very low.

Any time the flight surgeon encounters a contact lens problem which he cannot identify, he should recommend that the wearer discontinue using the lenses for several days. Many times the answer to the problem will then make itself known.

Perceptual Disorders

Visual Illusions

Visual illusions and other disorientation phenomena have been categorized by investigators relying on information from pilots and research subjects. These phenomena are important because in certain situations normal visual inputs cause abnormal sensations on the part of the pilot. Most of these illusions are experienced when visual acuity is decreased by disturbances such as darkness, rainfall, fog, haze, or the pull of gravity on the ocular system. Not all pilots experience these illusions, but they are frequent enough that the flight surgeon should be familiar with them and be able to discuss them intelligently. The exact cause of these illusions is not completely understood, but the fact that they do occur and present hazards to the pilot should be appreciated.

Autokinetic Illusion. An individual in virtually total darkness, observing a fixed point-source of light, will report seeing the light move. Individuals also have reported such movement when viewing a stationary black target against a homogeneously illuminated visual field. Such apparent movement of a fixed spot of light is known as autokinetic illusion. In the appropriate set of circumstances, most people will experience such movement. The autokinetic effect can, and does, produce a very dangerous situation during night flying. There have been reports in which pilots have followed lights on the ground, thinking these lights were from other planes until they were almost directly over the lights.

The autokinetic illusion can be attributed mainly to the involuntary movement of the muscles that control the eye. Under normal conditions, the perception of apparent motion of an object is controlled by other objects in the visual field. During night flying, the visual field is impoverished, and small light sources appear to move of their own accord. Inasmuch as training is ineffective against the autokinetic illusion, aviators must understand its operation and must learn to deal with it as it occurs.

Oculo-Agravic Illusion. The ocuio-agravic illusion has been demonstrated in aircraft in conditions which produce brief periods of reduced or zero-gravity forces. As an aircraft enters a zero-G

Ophthalmology

parabolic maneuver, a fixed visual target will appear to rise. When the aircraft reaches the zero-gravity phase, the target moves downward, with a subsequent rise again during the recovery pullout.

Prism Effect. Distortion of images has been reported by a number of pilots when viewing objects through a windscreen covered with rain. The cause of this is a surface of water, which is thicker near the bottom causing a prismatic effect. When the pilot looks through this, he, in effect, is looking through a base-down prism which tends to make objects look higher or closer to him than they really are. This causes errors in distance and height judgment and can be critical during landing or recovery aboard ship.

Waterfall Effect. A few helicopter pilots have experienced this illusion when hovering or when in slow flight at low altitudes over the surface of water. The downward blast of wind from the rotor blades causes the air to pick up water and to displace it upward at the periphery of the blade arc, and downward directly under the blades. A pilot might look out of his cockpit and see drops of water going downward in his field of vision. This would cause him to feel he was climbing, and make a corrective maneuver to descend, which would put him in the water.

Sloping Runways. Sloping runways can cause illusions in altitude judgment for aviators attempting to land. When the runway slopes away from the touchdown end of the runway, visual cues tend to make the pilot come in high and land long. If the runway slopes toward the touchdown end of the runway, visual cues tend to make the pilot come in lower than he should, with the chance of landing short of the runway. Aviators should be advised to monitor their altimeter closely when landing at airports having runways of this nature.

Pilot Fascination

Fascination is defined as a condition in which the pilot fails to respond adequately to a clearly defined stimulus situation despite the fact that all of the necessary cues are present and the proper response available to him. An earlier study of pilot experiences with fascination (Clark, Nichol森, & Graybiei, 1953) classified these experiences into two categories:

Type A fascination is fundamentally perceptual in nature. The individual concentrates on one aspect of the total situation to such a degree that he rejects other factors in his perceptual field. "Target" fascination is of this type and has been a fairly frequent cause of aircraft accidents. The pilot becomes so intent on hitting the target in an air to air gunnery run that he fails to observe the tow cable and collides with it. On an air to ground mission, he may become so intent on getting his bomb on target that he fails to observe his altimeter and pulls up from his dive too low. The following is an example of Type A fascination:

My instructor was teaching me how to make emergency landings on a small field. I had made one or two tries and hadn't been very successful. The next time I was determined to make a good approach. Both the instructor and I were so completely engrossed in the task that we failed to hear the landing gear warning horn. Consequently, we landed with the wheels in the up position.

In Type B fascination, the individual may perceive all of the significant aspects of the total situation, but still be unwilling or unable to make the proper response. The following is an example of Type B fascination:

I went into a skidded turn stall during a small-field shot. I knew I was in unbalanced flight during the last turn, but as I recall, I was so determined to get a straightaway before hitting the field that I didn't seem to care what happened. The plane stalled and the instructor took over.

Fascination has apparently been experienced by virtually all military pilots. The aviator must be made aware of such hazards and periodically reminded of them.

Although illusions and other disorientation phenomena are not as prevalent in the cause of accidents as the lack of scanning and poor depth judgment, they are potentially dangerous.

Flicker Vertigo

An unusual pilot response to a steady light flicker is occasionally encountered. Despite its rarity, the Flight Surgeon and all pilots should be aware of it and its devastating effects. A steady light flicker, at a frequency between approximately 4 and 20 Hz can produce unpleasant and dangerous reactions in normal subjects, including nausea, vertigo, convulsions, or unconsciousness. The exact physiological mechanisms underlying such reactions are not known. However, it is believed that susceptibility is increased when the pilot is fatigued, frustrated, or in a state of mild hypoxia. The following is a dramatic report of the manner in which flicker vertigo can occur:

After flying for some time at an altitude of 16,400 feet, a pilot in a single-seater propeller aircraft made a perfect landing. However, he did not taxi the plane to the hangar. Instead, the plane remained motionless, its propeller revolving slowly. The pilot was found bent over the controls, unconscious.

At first, it looked as though the pilot had not used his oxygen mask. However, in this case, the pilot had lapsed into unconsciousness after making a good landing.

Ophthalmology

The rays of the low-lying sun were shining on the slowly turning propeller blades. Reflected flashes of light were being thrown on the pilot's face at a rhythmic rate of about 12 per second.

In a study of 102 Navy helicopter pilots, researchers attempted to (1) determine the incidence of flicker vertigo or flicker problems during actual flight operations, and (2) to determine if any helicopter pilots in an operating squadron would reveal undue sensitivity to light as shown by marked EEG changes or unusual subjective sensations during exposure to photic stimulation in the laboratory. One-fourth of the pilots reported flicker during flight as annoying or distracting but in only one instance was a near-accident attributed to flicker. None of the EEG responses of this group to photic stimulation could be classified as even borderline abnormal. Photic stimulation thus does not appear to be a useful device to detect those who would show abnormal EEG activity during flicker. Photic stimulation, however, did identify pilots who had subjective feelings of discomfort during the flickering light. In addition, and perhaps of considerable importance, photic stimulation identified 22 pilots who became drowsy and showed lowered alertness during the period of stimulation.

Night Myopia and Night Presbyopia

Night myopia, also known as twilight myopia, is a phenomenon which causes some individuals with a small degree of myopia in daylight to become more myopic after dark and to have moderate symptoms of myopia. As an example: a pilot with 20/20 visual acuity in normal daylight hours with a plano to a -0.25 sphere refractive error in each eye may develop unaided vision of 20/30 to 20/40 in each eye and a refractive error of as much as -0.50 to -0.75 sphere. This condition can result in symptoms which would be hard to define unless the examining flight surgeon thinks of night myopia.

The Purkinje shift, chromatic aberration, spherical aberration, and ciliary spasm are factors which contribute in varying degrees to night myopia. An aviator who has symptoms compatible with night myopia should be evaluated thusly. First, visual acuity should be checked on the Armed Forces Vision Tester or in a well illuminated eye lane with a Snellen Chart. Usually the values will be 20/20 or slightly less. Then the eye lane should be darkened (except for the Snellen Chart) and visual acuity rechecked after approximately three to five minutes in the dark to allow the pupil to dilate. Many times the examiner will be surprised to find that now the visual acuity is two lines less than it was previously. The aviator should be refracted in the dim illumination, and one will usually find more myopic error. Prescribe this myopic correction for night flying.

Night myopia should not be over diagnosed. If a refractive error shows a moderate amount of plus sphere during normal lighting conditions, then the development of night myopia is unlikely.

Night presbyopia, also known as red light presbyopia, occurs in presbyopic individuals when subjected to red light. This is frequently encountered in the cockpits of aircraft during night operations. Red light has the longest wavelength of all lights in the visual spectrum. When one tries to read instruments or charts in red light, the demand for accommodation is more than if one were using white light. This causes difficulty reading small print in presbyopes. When aviators complain of these difficulties, it is usually wise to prescribe a pair of flight glasses with a stronger add for night operations than the add indicated for day operations.

Space Myopia

The term space myopia is used to describe the myopia experienced by aviators when there is “nothing to look at” outside the cockpit. One example of this would be the pilot who is flying VFR on top. The clouds prevent him from seeing the ground, and the light reflected from the cloud layer beneath his aircraft puts him in an environment where there are reduced visual cues. His eyes, having nothing else to focus on, will tend to “lock-in” on the aircraft instruments and remain fixed for this distance. When he looks outside the cockpit, his eyes remain fixated for near distances because there are no targets for him to observe. This myopic situation could cause him to be unable to see other aircraft when they would otherwise have been seen. To alleviate this myopia, it is recommended that an aviator look at the wingtips of his aircraft from time to time to allow relaxation of his ciliary muscles.

Topics of Interest for Safety Lectures

Scan and Avoidance of Midair Collisions

Most midair collisions occur in daylight VFR conditions, which should offer a safe environment for flying. Obviously, then, there must be contributing factors which lead to midair collisions other than bad weather and poor visibility. Analysis of midair collisions have borne out the fact that most of these collisions occur in high aircraft density areas such as military training areas, civilian training areas, at the periphery of high density airports and at other airports, and over frequently used navigational aids. Most of these occur at low level altitude (below 3000 feet AGL) when the hemispheric rule of flight is not observed. The most frequent cause cited by aircraft investigation boards for these midair collisions is the failure of the old adage “see and be seen”. In other words, the pilot of one or the other or both of the aircraft involved failed to continue to use a good scan pattern. They became complacent or preoccupied with flying the aircraft and flew into one another.

A good scan technique requires good central and peripheral visual acuity, freedom from glare (by correct use of sunglasses and visor), and a windscreen or canopy clear of dirt, moisture, and

Ophthalmology

scratches. In addition, the individual performing the scan must be mentally alert and feel well physically to do an adequate job. Fatigue, hypoxia, hangovers, or any medications which might interfere with mental alertness should be avoided when flying.

The Aviation Safety Officer (ASO), instructor pilots, and flight surgeon must continually emphasize the importance of good scan techniques. They must emphasize that of all factors available, the “see and be seen” philosophy is the greatest aid to safe flying. The ASO of each squadron usually has information and pictorial displays depicting how a good scan should be performed. This should be the topic of frequent safety lectures. The flight surgeon can present information on the need for good visual acuity and other health factors.

Approach and Landing Accidents

The largest percentage of all aircraft accidents occur in the approach and landing phase of flight. This refers to military aircraft, commercial air carriers, and civilian pleasure and business aircraft. Experienced aviators appreciate this phase of the flight as being the most dangerous. Factors contributing to this dangerous situation fall into two categories. The first belongs in the category of flying the aircraft. More attention and skill is needed in control of the aircraft during this phase of flight. The second category falls in the category of visual cues or lack of visual cues in performing a successful landing.

Factors involving controlling the aircraft include: transitioning from a straight and level flight at altitude to a flight which is descending, slowing, and making frequent changes in headings. In addition to this the pilot must establish communication with approach control or the control tower. He must “set up” the aircraft to make the appropriate type of approach and prepare the aircraft for contact with the ground (runway). The pilot also must be prepared for a missed approach. The successful performance of this phase of the flight requires a tremendous amount of attention on the part of the pilot. All of these factors, plus the higher density of traffic, contribute to the inherent danger of the landing phase.

The second important aspect of landing concerns the use of visual cues. The pilot must judge accurately his height above the terrain, distance to touchdown, and speed of the aircraft. These are learned uses of visual information which come from many hours of flight time and an understanding of the binocular and monocular cues to distance judgment. Conditions which interfere with visibility such as darkness, clouds, haze, rain, fog, etc., contribute to a lack of visual cues at this phase of flight. Obviously this phase of flight is most demanding in the skills and attention required of the pilot and the flight crew.

A good discussion of cues to depth judgment and other factors can be found in the excellent article written by Robert H. Riordan, MD of the Medical Department of TWA: "Visual Perception in Approach and Landing Accidents," presented at the International Air Transportation Association in Istanbul, November 10-15, 1975. Dr. Riordan analyzed air carrier accidents throughout the world from 1962 to 1974. He found that of 196 air carrier accidents, 50 percent occurred during the approach and landing phase of flight, and 75 percent of these occurred at night or in rain and IFR conditions when visual cues to depth judgment were decreased or absent. In 25 percent of the accidents, pilot misjudgment of distance, altitude, or speed were factors in causing the accidents.

Dark Adaptation

The flight surgeon will frequently be called on to lecture aviators on the importance of and techniques for dark adaptation. The mechanisms of dark adaptation are, of course, well known to medical personnel. Pilots, however, should be reminded of the time - approximately 30 minutes - to achieve complete dark adaptation. Factors in aviation which enhance dark adaptation are the avoidance of bright white light and the use of dim illumination in the ready room. Red lighting is not necessary, unless very bright lighting is required. Other factors affecting 'dark adaptation include avoiding smoking and the use of 100 percent oxygen in flights above 4000 feet MSL. Obviously all night flights do not require total dark adaptation (most are actually done under mesopic conditions), but in many situations, such as maneuvering aircraft on a dark carrier deck, dark adaptation is quite important.

Lasers in Aviation

There is a great deal of research and interest in the use of lasers in aviation, and the field changes daily. Lasers are used primarily in target acquisition, ranging, and aiming, and so far are not primarily antipersonnel or antimaterial weapons. However, they may be employed to dazzle or flash blind, and therefore, of course, frustrate the pilot's attempt to zero in on a target. Since there are very many laser wavelengths, no protective eyewear (that can be seen through) can protect against all types.

In some ways, laser exposure is similar to ordinary light; indirect exposure to bright sunshine is of course harmless, but looking directly at the sun magnifies its power 10,000 times and will catastrophically burn its focal point, the macula, in only a few seconds. For this reason, visible wave length lasers (400-700 nanometers) are the most dangerous to the eyes. Also, near infra-red wave lengths still focus on the retina, are used in many target designators, are not visible, and so are especially hazardous.

Ophthalmology

The current laser protective goggles are a compromise and protect against the most commonly used wavelengths. Serious eye (or even bodily) injury at present is a problem mostly in accidental exposure to personnel working with lasers, and at very close ranges. This, of course, could change before this material is even printed. Obviously directed energy that is capable of destroying an aircraft in midair can destroy human tissue, but there is a large aura of scare talk about the devastating effects of war lasers on eyes which happily so far is mostly fantasy.

Evaluation of laser eye injuries follow standard procedures for any eye examination. "Treatment" of laser eye injuries is basically triage since there is no specific therapy for most retinal injuries, and the eyelid and corneal injuries are treated like any other burn.

Night Vision Goggles

Night vision goggles (NVG's) are designed to electronically amplify moonlight and starlight to display images on a small video screen mounted within the apparatus. Presently, there are two models of NVG's utilized within naval aviation: PVS-5 and ANVIS (Aviator's Night Vision Imaging System).

The PVS-5/C is an improved version of the first generation of NVG which was originally used by the Army and Marines. It has been modified for use in aviation. The ANVIS, on the other hand, has been specifically developed for use in modern aircraft as well as land based vehicles.

Both models of NVG's are receptive to the visible spectrum and near IR radiation. The PVS-5's response is between 500 nm (blue green) and 850 nm (IR), while the ANVIS has a blue-green cut off and a range which extends a little more into the IR range. This allows the instrument to be much more sensitive in the red and near IR end of the spectrum.

Images produced by NVG's are elicited by photons striking a photocathode, which in turn causes a release of electrons within an adjacent microchannel plate. An electric field then guides the electrons to a phosphor screen which produces an amplified light image. The image produced is green, which disallows for any color discrimination of objects. Both the PVS-5 and the ANVIS have automatic brightness controls which limits the maximum luminance of the phosphor screen to prevent output surges and minimize the change of decreasing dark adaptation. A clamp voltage mechanism is present to protect against excessively bright light sources (search lights, flares, flashlights, lasers, etc.).

The ANVIS has incorporated many improvements, including: compatibility to be used with eyeglasses; easily mountable to helmets; "look under" capability, which allows normal peripheral

U.S. Naval Flight Surgeon's Manual

vision to view flight controls; a fail-safe battery warning system; and less weight and counterbalancing on helmet. The most important technical advantage of the ANVIS is its greater sensitivity at low light levels. The ANVIS produces an image with greater contrast and resolution, resulting in longer detection ranges when viewing objects illuminated with starlight. This is not always an advantage, because under certain, unusual lighting conditions (moonlit nights with shadows cast over terrain), users have reported that the ANVIS did not create a difference in contrast between adjacent terrain features.

Two important points to realize when teaching about and utilizing NVG's are the facts that with the PVS-5, the *best possible* visual acuity is in the 20/50 range while the ANVIS will afford about 20/40 acuity, and the users depth perception will be greatly degraded.

Bibliography

General Ophthalmology

Ellis, P.P., & Smith, D.I. *Handbook of ocular therapeutics and pharmacology* (4th ed.). St. Louis: Mosby, 1973.

Scheie, H.G., & Albert, D.M. *Adler's textbook of ophthalmology* (8th ed.). Philadelphia: Saunders, 1969.

Vaughan, D., & Asbury, T. *General Ophthalmology* (11th or most recent ed.). Los Altos, CA: Lange Medical Publications, 1986. (Or contact Pennsylvania College of Optometry Bookstore, 1200 W. Godfrey Ave., Philadelphia, PA 19141 (215) 276-6000). * Paperback, Concise, "The Mini- Bible".

Refraction and Lenses

Sloane, A. *Manual of refraction* (2nd ed.). Boston: Little, Brown and Co., 1970.

Trauma and Ophthalmologic Emergencies

Gombos, GM. (Ed.). *Handbook of ophthalmologic emergencies*. (Medical Handbooks). Flushing, NY: Medical Examination Publishers, 1973.

Annual Physical Examination on Flight Personnel

Department of the Navy. *Manual of the Medical Department* (NAVMEDI17). Washington, DC: U.S. Government Printing Office.

Perceptual Disorders

Anonymous. Notes from your flight surgeon. *Approach* (Naval Aviation Safety Review), 1956, 2, 33.

Clark, B., Nicholson, M.A., & Graybiel, A. Fascination: A cause of pilot error. U.S. Naval School of Aviation Medicine, Proj. NM001 059.01.35. Pensacola, Florida, May 1953.

Johnson, L.C. Flicker as a helicopter pilot problem. *Aerospace Medicine*, 1963, 34.

Ophthalmology

Topics of Interest for Safety Lectures

Riordan, R.H. Visual perception in approach and landing accidents. Paper presented at the International Air Transportation Association Meeting, Istanbul, November 10-15, 1975.

Additional Reading

Clinical Ophthalmology, Duane (Index and 5 Volumes, Revised Edition) Philadelphia: Harper and Row, 1987 (or latest edition). "The Bible".

Physician's Desk Reference for Ophthalmology. Oradell, NJ: Medical Economics Co., Latest Edition.

CHAPTER 10

DERMATOLOGY

Introduction
Aircraft Carrier “Mystery Rash”
Skin Complications Due to Environmental Factors
Additional Common Dermatological Diseases
Differential Diagnosis - Treatment Guide
Dermatology Medications
References

Introduction

Approximately 50 percent of the sick call problems aboard an aircraft carrier are dermatologically related. There are several factors that contribute to this high figure. These include: (1) age group, (2) adverse environmental factors, (3) motivation of the patient, and (4) the recalcitrant nature of dermatological disease itself.

Deploying medical departments should send their laboratory technicians and a sick call corpsman to work as learning participants in the dermatology clinic of the nearest large naval hospital for two to five mornings of active duty sick call. They will see nearly every dermatology problem that they will encounter while deployed. And they will have opportunities to review and perform KOH and Scabies preparations, and darkfield examinations.

It is recommended that the medical department’s library be reviewed prior to deployment. *The Manual of Skin Diseases* by Sauer is thorough enough to adequately inform flight surgeons about any of the rare or unusual dermatological diseases that they may encounter. The following atlases may also be helpful: *Color Atlas of Dermatology*, *Color Atlas of Infectious Diseases*, and *Color Atlas of Sexually Transmitted Diseases*.

This chapter will not discuss sexually transmitted diseases since they are covered in Chapter 11.

Aircraft Carrier "Mystery Rash"

There is no such entity as a strange, contact dermatitis seen only aboard ships which seems to clear up after a short liberty period on the beach, air evacuation to Germany, or while awaiting a dermatology consultation at a naval hospital. Most frequently this rash is a miliaria rubra or "heat rash." The heat and humidity associated with many of the work and living spaces aboard ship cause the tropical-like heat rash. This rash is frequently aggravated by overtreatment, bathing, and soaps. It is best treated by removing the individual from the heat stress; and, recommending that the person change clothes frequently, wear only cotton materials, and avoid prolonged bathing or soap exposure.

The normal skin has a pH of 5.5. Many soaps are alkaline, often in the pH range of 12 to 13. Many of the "deodorant" soaps contain antibacterial agents and perfumes which can cause a contact irritation allergy or photoallergy. The combination of constant high humidity, coupled with incomplete rinsing, produces an exaggerated percentage of such reactions. "Irish Spring" is one of the most irritating soaps in use. Individuals with "dry" or "normal" skin should reduce the frequency of bathing, decrease both the temperature and the duration of showers, and use one of the soap substitutes, such as Lowilla, Basis, Casteel, Oilatum, Aveeno, or Alpha Keri.

Skin Complications Due to Environmental Factors

For many of a carrier's inhabitants, the working conditions are unaffected by the weather. Their working spaces will remain a heat stress area even while in Arctic waters, and there will always be crowded berthing conditions. Acne, contact dermatitis, fungal and bacterial infections, and other dermatological conditions are caused or aggravated by the heat and humidity. Scabies or louse infestation can go through an entire berthing area. The following conditions are seen in a much higher percentage aboard a carrier than at an air station dispensary.

Scabies

During a recent world-wide epidemic of scabies, the condition was the most frequently misdiagnosed disease seen by a dermatologist. The obvious clues are intense pruritus, especially at night, and the affliction of other family members or sex partners. The classic scabies distribution is on the glans penis, finger webs, and elbows. It is rarely seen on the face. It requires approximately four to six weeks after skin exposure to develop symptoms, and the disease always responds to topical gamma benzene (Kwell). Application of Kwell to the entire body from the neck down after bathing, and leaving it on the body for 24 hours before washing again is recommended. Deviation from this schedule may result in treatment failures. All bedding and clothing

Dermatology

should be freshly laundered. The same procedure should be repeated within two to seven days. The patient is likely to continue to itch for several weeks after treatment and may suffer some degree of parasite phobia for months. Occasionally, a secondary bacterial infection may develop from excoriation. The patient may reinfect himself from a friend or animal. A patient may be helped by the prescription of Atarax and a topical steroid cream after the Kwell treatment to relieve the pruritus while the dead epidermal parasites are being exfoliated. Kwell is also effective for the crab lice infestations which are a rather common shipboard entity.

Dermatophytosis

Fungus infections are the next most often misdiagnosed or ill-managed dermatological disease. A simple KOH Prep must be performed for every suspected case of dermatophytosis before commitment to treatment. Aboard ship, two antifungal agents should be sufficient. There is an all-purpose topical fungicide available through the federal stock system that is usually effective against all forms of fungus including true tinea, monilia, and tinea versicolor. This fungicide (two percent miconazole nitrate) is available in either 85-gram tubes under the label of Monistat, or in one-ounce tubes under the label of Micatin cream. This should reduce or eliminate the need for stocking Tinactin, Mycostatin, Fungizone, Vioform, Mycolog, Halotex, or Desenex. Selsun shampoo should also be used in conjunction with the Monistat or Micatin in tinea versicolor. In true tinea infections, which can be easily distinguished from monilia or tinea versicolor with a KOH Prep, griseofulvin (500 mg B.I.D. with meals) is effective, especially if lesions are located in hairy areas, nails, or in granulomatous reactions. The treatment of any toenail fungal infection should be referred to a dermatologist as therapeutic results are frequently disappointing.

Pyoderma

Another complication of the humid environment is pyoderma. Impetigo is usually caused by B-hemolytic streptococci; and, is frequently associated with *Staphylococcus aureus*. It needs systemic treatment. The drug of choice is erythromycin (250 mg QID for ten days). Topical bacitracin-neomycin cream and pHisoHex soap should be used in conjunction with the oral antibiotics.

Acne

Acne is frequently aggravated by the ship's environment. A folliculitis-like acne condition may be seen on the thighs, buttocks, and arms of a patient who works in an oil-contaminated area, especially one who is exposed to the halogenated hydrocarbons in a machine shop. A tropical-like acne frequently develops on the trunk due to the macerating effect of prolonged exposure to wet clothing. Each case should be individualized. Most need a benzoyl peroxide desquamating agent and oral tetracycline. If deep papules or cysts exist, the patient will need long-term tetracycline

treatment (250 mg BID or QID one hour a.c.). Initially, there may be an irritating effect with the above treatment, followed by slow improvement. It often requires four to six weeks to see obvious changes. If the condition is severe, the patient should be removed from hot, humid, or greasy areas. Occasionally, a keloidal acne occurs on the sternum, scalp, or nape area of Black persons. These lesions will require intralesional injections of Kenalog (5 mg/cc) and cautious hygiene. On rare occasions a Gram-negative rod infection will develop in a patient on long-term tetracycline. This is easily identified by the clinical appearance of multiple superficial pustules. Except for this rare complication, all acne patients should be considered noninfectious; and, no waivers prohibiting haircuts or mess cooking should be considered.

Additional Common Dermatological Diseases

Pseudofolliculitis barbae (pfb) is an inherent problem associated with Black males who shave. The razor produces a sharpened tip on the recurved hair. This allows the hair to reenter the skin. The intruding hair acts as a foreign body and an infectious or granulomatous condition develops. Black marines are required to keep a clean-shaven appearance. The use of depilatories is advised. Under certain conditions, a waiver may be granted. The patient should be evaluated by a dermatologist.

Warts, especially plantar warts, are ubiquitous in healthy sailors. Corpsmen can be taught to treat warts with weekly paring, application of trichloroacetic acid, and 40 percent salicylic plasters. Other warts can be treated with electrocautery, Cantharone, or liquid nitrogen. Podophyllin (20 percent in tincture of benzoin) should be reserved for venereal warts in uncircumcized sailors and on the perirectal area.

Dandruff or seborrheic dermatitis can flare under the stress of a cruise and usually presents no problem for diagnosis. A tar shampoo such as Sebutone and a steroid lotion such as .01 percent Synalar can be used. The same medications can be applied to the scalp of psoriatic patients along with a topical Aristocort preparation for the skin lesions.

Acutely inflamed dermatological conditions which are manifested by erythematous, edematous, oozing vesicles or pustules should be treated with Burow's compresses until the lesions begin to dry. This would include pyodermas, infected lesions, as well as allergic, and inflammatory diseases. Usually one Burow's tablet in one quart of tepid tap water, for use as a compress to the dry area for 15 minutes t.i.d., will suffice. Once a lesion becomes dry, soaks or compresses should be reduced and appropriate cream or ointment therapy should be initiated.

Dermatology

Differential Diagnosis-Treatment Guide

The following diagnostic guide is suggested for use by the corpsman in sick call. It should help diagnose and treat about 95 percent of the dermatology complaints.

Jock Itch

Differential Diagnosis:

Tinea cruris	Positive KOH Prep for dermatophyte.
Monilia	Positive KOH Prep for yeast.
Contact dermatitis	History of irritant soap, medication, or heavy metal exposure.
Venereal warts	Viral; contagious venereally.
Molluscum contagiosm	Viral; contagious venereally.
Herpes simplex	Viral; contagious venereally.
Scabies	Positive scabies prep; contagious venereally.
Crab lice	Contagious venereally.
Erythrasma	Corynebacterium; positive fluorescence with Wood's light; noncontagious; associated with poor hygiene.

Treatment:

Tinea cruris	Keep dry; miconazole or griseofulvin.
Monilia	Keep dry; miconazole.
Venereal warts, Molluscum contagiosum	Podophyllin, liquid nitrogen.

U.S. Naval Flight Surgeon's Manual

Herpes simplex	Burow's compresses, topical antibiotic, Acyclovir p.o. or topical.
Scabies, lice	Kwell.
Erythrasma	Topical neomycin powder, erythromycin.
All others	Steroid cream, I.M. steroids if severe (nonfungal).

Athlete's Foot

Differential Diagnosis:

Tinea pedis	Positive KOH Prep; frequently unilateral.
Bacterial infection	Macerated toe webs, pustules, foul odor.
Eczema	Frequently symmetrical, pruritic; familial.
Dyshidrosis	Blisters, pustules; chronic, moderate to severe pruritis.
Contact dermatitis	Blisters, pruritic, frequently symmetrical.
Neurodermatitis	Scaly; chronic.

Treatment:

Tinea pedis	Keep dry; cotton socks; powders; miconazole or griseofulvin.
Bacterial infection	Keep dry; talc powder; erythromycin.
Eczema, dyshidrosis, contact dermatitis, neurodermatitis	Keep clean and dry, avoid contact with offending agents, topical steroid cream, antihistamines, I.M. steroids if severe.

Dermatology

Itching

Differential Diagnosis:

Urticaria	Positive history, lesions moving around within 24 hours.
Drug eruption	Positive history.
Neuroses	Positive history or MMPI.
Soap/detergent/bleach/ clothes softener contact dermatitis	History of deodorant soap or detergent use, or recent change in brand used; noted in morning, especially if member sweats profusely.
Scabies	Positive scraping.
Miliaria rubra	Heat rash, especially in covered areas or body folds.
Erythema multiforme	Stationary, annular lesions.

Treatment:

Urticaria	Keep cool; Atarax; epinephrine; topical steroids (systemic if severe).
Drug eruption	Same as urticaria, eliminate drug.
Neuroses	MMPI; Atarax, (Thorazine if severe).
Soap contact dermatitis	Discontinue offending soap, detergent, bleach, or softener; use tepid showers; topical steroids; Atarax.
Scabies	Kwell.
Miliaria rubra	Remove patient from hot, humid area; clean, dry, soft, cotton clothes; Atarax.

Erythema multiforme

Refer to medical officer for workup.

Papular Squamous Lesions

Differential Diagnosis:

Tinea	Positive KOH Prep for dermatophyte; annular, non-symmetrical lesions which enlarge slowly.
Tinea versicolor	Positive KOH Prep; lesions on trunk; sweaty, oily skin, worse in summer, may leave depigmented areas.
Pityriasis rosea	Symmetrical tan/pink lesions, not on face or hands; negative KOH preparation, negative RPR (VDRL).
Seborrheic dermatitis	Lesions in the nasolabial, sternal, medial brow, and scalp areas.
Secondary syphilis	Positive VDRL; frequently plantar or palmar lesions; alopecia; notify EPMU.
Eczema, neurodermatitis	Itching, worse with anxiety provoking situations.
Psoriasis	Elbows, knees, and scalp frequently involved; chronic, erythematous plaques with silvery scales, usually nonpruritic.
Contact dermatitis, dermatitis medicamentosa	Positive history, more frequently seen on palms and soles, pruritic.
Lichen planus	Lesions on penis, mouth, wrist, and ankles; violaceous or white color, pruritic, Koebner reaction.
Lupus erythematoses	Lesions on sun-exposed areas, especially the face, leaving atrophic scars.

Dermatology

Treatment:

Tinea	Keep dry; miconazole or griseofulvin.
Pityriasis rosea	Topical steroids, creams for small areas, lotions for large or hair covered areas.
Tinea versicolor	Miconazole; keep dry; Selsun.
Seborrheic dermatitis, eczema, contact dermatitis, neurodermatitis, lichen planus	Topical or systemic steroids.
Lupus erythematosus	Topical or systemic steroids; sun screens; a biopsy is indicated; refer to medical officer.
Psoriasis	Tars; topical steroids; avoid systemic steroids.
Dermatitis medicamentosa	Stop causative drug; systemic steroids, antihistamines.
Secondary syphilis	See Chapter 11, <i>Sexually Transmitted Diseases</i> .

Blisters

Differential Diagnosis:

Herpes simplex	On lips or genitalia; recurrent; painful.
Herpes zoster	Linear; unilateral; painful.
Varicella	Generalized; febrile; positive history.
Tinea	Positive KOH Prep.
Contact dermatitis	Pruritic; positive patch test.
Impetigo	Positive culture; positive Gram stain; may have crusting, bullous, or weeping lesions.

Dermatology

Furuncles, carbuncles Deep; painful, usually more than 1 cm in diameter.

Cellulitis, erysipelas Unilateral; red, hot, swelling, painful febrile.

Treatment:

Acne Tetracycline; benzoyl peroxide; Fostex shampoo, good hygiene, avoid self manipulation of comedones.

Folliculitis Keep dry; clean, loose dry, cotton clothes. Antibiotic per culture.

Impetigo Erythromycin; pHisoHex; topical neomycin.

Pseudofolliculitis barbae No-shave chit after documentation, diagnosis, and dermatology consult.

Furuncles, carbuncles Erythromycin; hot soaks; pHisoHex; I & D.

Cellulitis, erysipelas Refer to medical officer, admit to ward, systemic antibiotics.

Hair Loss

Differential Diagnosis:

Tinea Annular, scaly lesions; broken hairs; positive KOH Prep.

Secondary syphilis Positive VDRL; patchy loss; notify EPMU.

Alopecia areata Annular; no scalp changes.

Scar History of trauma or previous scalp diseases.

Male pattern baldness Familial history.

Breakage of hair shaft Usually in Blacks.

Treatment:

Tinea Griseofulvin.

Secondary syphilis Penicillin; notify EPMU.

Alopecia areata Intralesional Kenalog (5 mg/cc).

Scar Intralesional Kenalog if keloidal (20-40 mg/cc).

Male pattern baldness Topical minoxidil possibly effective.

Breakage of hair shaft Discontinue use of hair straighteners, hot comb, hair pic, excessive brushing, alkaline shampoos, traction (corn-row).

Dermatology Medications

Dermatology preparations or medications are predictably redundant and obsolete aboard a carrier. Many of the antifungal agents are similar and ineffective. An excellent product for a carrier's pharmacy to stock is Aristocort cream (Lederle). This can be readily made into a cream or ointment with variable strengths. Creams are most often used for the acute inflammatory lesion, and an ointment is best for the chronic scaly dermatoses. Ointments should generally be avoided in the hot, humid climates which prevail in many of the ship's spaces. Occasionally, a steroid solution or lotion may be indicated for a hairy body region (Snytex's 20 cc, 0.01 percent Synalar solution). A steroid spray may be indicated for first or second degree burns or arthropod bites; 90-gram cans of Valisone, Deca, or Kenalog spray are recommended. Occasionally an intraoral medication is indicated such as Kenalog in Orabase (five-gram unit). If a parenteral steroid is indicated, and if the condition requires more than two weeks of treatment, prednisone should be avoided in favor of I.M. administration with either multidose Kenalog (40 mg/cc), 5cc vial (Squibb), or 5cc vials of Celestone (Schering). Because of its insolubility, a single injection of Kenalog will often satisfy a patient's need for a month. There is usually a 24-hour delay before the drug is initially effective. A similar quantity of Celestone will react initially in a few hours and will hold the patient for approximately three weeks. The equivalent dosage of oral prednisone needed for similar clinical response will be in the 30 mg per day range and may induce more adrenal suppression, even with single, daily doses. If a parenteral steroid is chosen, the in-

Dermatology

intramuscular route is preferred, since it assures dosage control. The steroid should be given deep intramuscularly (hip) with at least a 1 1/4 inch needle. Subcutaneous atrophy has occurred from superficial injections. Parenteral Kenalog, diluted with xylocaine to 5 mg/cc, can be injected intralesionally into thick patches of neurodermatitis, psoriasis, or into areas of alopecia areata.

Mycolog cream is not recommended for frequent use. Its combination of steroid, antimonial, and antibacterial agents requires many stabilizers and preservatives which can potentially produce a contact allergy. A pharmacy technician should be able to compound any two or three active ingredients as needed. This will alleviate the over-dispensing of this very expensive cream. The following preparations should be considered sensitizers, of uncertain effectiveness, or unreasonably costly: Mycostatin ointment, Tetracaine ointment, Eurax cream, Furacin ointment, Desenex solution and ointment, Castellani's paint, and Vioform-Hydrocortisone cream. Tacaryl or Tenaril are ineffective for itching; topicals and Atarax p.o. are preferable. It is better to become familiar with a few drugs and methods of treatment than to attempt the use of many.

References

- Bhutan, L.K. *Color atlas of sexually transmitted diseases*. St. Louis: Ishiyaku Euro-American Publishers, 1988.
- Emond, R.T., *Color Atlas of infectious diseases*. Chicago: Year Book Publishers, 1987.
- Levene, G.M. *Color atlas of dermatology*. Chicago: Year Book Medical Publishers, 1984.
- Sauer, G.C. *Manual of skin diseases*. Philadelphia: Lippincott, 1986.

CHAPTER 11

SEXUALLY TRANSMITTED DISEASES

Introduction

Gonorrhea

Nongonococcal Urethritis (NGU), Mucopurulent Cervicitis

Genital Herpes Simplex Virus

Syphilis

Chancroid

Lymphogranuloma Venereum (LGV)

Ano-Genital Warts (Condyloma acuminata)

Molluscum Contagiosum

References and Bibliography

Appendix A: Treatment Regimens: Gonorrhea, NGU, Mucopurulent Cervicitis, and Syphilis

Appendix B: Laboratory Tests for Gonococcal Infections

Appendix C: Evaluation of Genital Ulcers

Introduction

The spectrum of sexually transmitted diseases (STD) has exploded in depth, breadth, and complexity. The days of “VD,” which dealt largely with uncomplicated “clap” and “syph,” are long gone. Now there are pandemic and hyperendemic STDs, some of which can be fatal and threaten to wipe out entire populations. The area is rapidly evolving into a subspecialty in its own right: genitourinary medicine. In Great Britain there are departments and clinics devoted solely to this subspecialty. Encyclopedic textbooks have been produced, at least two of which are devoted to STD’s in women.

Sexually transmitted diseases encompass 25 or more entities which are usually transmitted by some type of sexual intercourse. To reflect this spectrum of etiological agents, the term “sexually transmitted diseases” has replaced the older term “venereal diseases” (VD). Many agents are transmitted among adults exclusively, or nearly so, by intimate sexual contact in all its myriad forms. Others (e.g., hepatitis A, *Entamoeba histolytica*), are more often transmitted by unsexual means, but may also be spread by some sexual practices (e.g., anilingus). Other diseases (e.g., scabies) do not require sexual intercourse *per se* for transmission, but are a by-

product of the physical closeness of sexual intimacy. Obviously, the medical evaluation of a patient presenting with the complaint of an STD needs to be comprehensive; often there is more than one STD although the patient may not be aware of, or complain about, the others.

The spectrum of sexually transmitted diseases includes: bacterial agents (*Neisseria gonorrhoeae*, *Chlamydia trachomatis*, *Mycoplasma hominis*, *Ureaplasma Urealyicum*, *Gardnerella vaginalis*, *Treponema pallidum*, *Hemophilus ducreyi*, *Chlamydia granulomatus*, group B streptococci, *Shigella* species); viruses (herpes, hepatitis A, hepatitis B, pox virus (*Molluscum contagiosum*, human papilloma virus, cytomegalovirus, human immunodeficiency virus); fungi: (*Candida albicans*); protozoa (*Trichomonas vaginalis*, *Entamoeba histolytica*, *Giardia lamblia*); and ectoparasites (*Phthirus pubis*, *Sarcoptes scabiei*).

This chapter will limit itself to the most common STDs, which have significant, or primarily, genital manifestations. Thus, at least two highly important STDs - both of which may be fatal, acquired immune deficiency syndrome (AIDS) and hepatitis B - are not covered in this chapter (see Chapter 5, *Internal Medicine*). The emphasis is on what is treatable, and what is likely to be seen in an operational setting, with the concomitant constraints on diagnostic and treatment modalities. For the same reason, the management of STDs in pregnancy or in neonates is only touched upon; expert advice should be sought in these situations. The rapidity of change in this area cannot be overemphasized. At a minimum, a subscription to *Morbidity and Mortality Weekly Reports* is highly recommended to assist in keeping current, particularly through its periodic supplements devoted to STD treatment. (Details for subscribing are found in the *References and Bibliography*.) The latest Naval Medical Command and area STD instructions are mandatory reading. These are particularly useful for administrative issues, but sometimes are not current with the latest treatment recommendations. The latest instruction, in fact, simply incorporates the latest Centers for Disease Control recommendations, and the intention appears to be to continue this practice in the future. To assure having the most current recommendations for overseas, the appropriate Naval Environmental and Preventive Medicine Unit should be consulted.

Equally important to up-to-date treatment regimens is the need for identification and treatment of sexual contacts. This is accomplished through the preventive medicine technician (PMT), at least one of whom is assigned to most Navy and Marine Corps activities. Larger activities have preventive medicine departments which can be useful sources of information. By Navy policy, and state and local law, certain STDs are reportable to the local health authorities. It is the PMT's task to try to accomplish this, but the PMT first has to be informed of the patient by the medical department.

Gonorrhea

Introduction

The spectrum of disease is far greater than simple “clap.” Overall, up to 10 percent of men may have asymptomatic infections. Women seen in family practice and VD clinics are typically asymptomatic, but up to 90 percent of women hospitalized for gonorrhea have symptoms. However, these are typically mild and nonspecific (vaginal discharge, itching, dysuria); too often dismissed as cystitis or vaginitis. If thinking of gonorrhea, culture.

Treatment

Treatment regimens may be found in Appendix A.

Urethritis

Urethritis is the most common gonococcal disease. It occurs after two to eight days incubation, although occasionally as long as 18 days are required. Most cases have abrupt onset, severe dysuria, and copious purulent discharge, but mild cases occur and may mimic nongonococcal urethritis (NGU). Gram stain is positive in 85 percent of cases in men, and the presence of gram negative diplococci (GNDC) is essentially diagnostic. (The old requirement, that the GNDC is intracellular, has little validity and should be discarded.) Ideally, four hours should have elapsed since the patient last urinated. Advantages of pretreatment cultures:

1. No need to obtain a repeat specimen (for culture) if the Gram stain is nondiagnostic.
2. Only way to detect resistant organisms.
3. Some cases of NGU, as diagnosed by Gram stain, are culture positive for gonorrhea.

Endocervicitis

Most cases are asymptomatic or mildly symptomatic. Gram stain is of limited usefulness (only 50 to 65 percent positive). Gonococcal culture is mandatory in all suspect cases, and must be from the endocervix. Anal cultures detect an additional two percent of cases.

Test-of-Cure Cultures

Four to seven days after completing treatment. (Since current regimens include seven days of a

tetracycline, the test-of-cure-culture must be obtained four to seven days after completing the tetracycline.) In women, both rectum and cervix must be cultured.

Resistant Organisms

Penicillinase-Producing Neisseria Gonorrhoeae (PPNG). PPNG is common throughout Southeast Asia and many parts of Africa, and is endemic in Los Angeles, New York City, Miami, and San Diego County. The Western Pacific, Korea, and the Phillipines have high rates of gonorrhea resistant to penicillin and spectinomycin, although some isolates are resistant only to spectinomycin. In Miami, North Carolina, and many other states, *relative* penicillin resistance is common, as it is also in Southeast Asia. Most labs do not test directly for penicillin sensitivity, and these organisms are usually reported as “beta lactamase negative,” implying penicillin will work. However even without this enzyme, the level of relative (chromosomally mediated) penicillin resistance is sufficiently high that penicillin and ampicillin have unacceptably high failure rates.

In third world countries, the prevalence of tetracycline-resistant gonorrhea is sufficiently great, that this antibiotic can no longer be used. A recent study from Seattle reported a 10 percent failure rate in treating gonorrhea with tetracycline, and the CDC has identified a total of 99 isolates, from 17 states, as being resistant to tetracycline. Thus, now even in the United States, tetracycline is no longer an acceptable drug for treating gonorrhea.

Gonococcal resistance is clearly increasing both in number of cases, and variety of resistance patterns. A test-of-cure culture is mandatory in all cases, even those asymptomatic after treatment. Isolates from treatment failures should be tested for both beta lactamase production (if not previously done), penicillin sensitivity, and spectinomycin sensitivity if that agent failed. Treatment failures should be treated with spectinomycin (2 gram IM) if not previously used, or with ceftriaxone (250 mg IM). (Special treatment recommendations apply in California and the Western Pacific. See Appendix A.)

Treatment Failures May Also Be Epidemiologic. (1) Patient may be reinfected by a new partner or an untreated old partner. (2) Treatment of patient and partner may not have overlapped, thereby allowing the infection to “ping pong” between partners. (3) Failure to eradicate organisms from rectum or pharynx of patient or partner.

Gonorrhea Plus Syphilis

All of the above regimens, *except spectinomycin used alone*, are likely to abort *incubating* syphilis. “Incubating” means no skin lesions (chancre, rash), and a negative serology. If these

Sexually Transmitted Diseases

conditions are not met, the patient requires treatment with benzathine penicillin G for syphilis, plus treatment for gonorrhea. If only spectinomycin is used, the patient should have a follow-up syphilis serology for three months. If a tetracycline is used with spectinomycin, to treat coinfecting chlamydia, the tetracycline should abort any incubating syphilis.

Epidemiologic Treatment

If a patient has gonorrhea, all sex contacts are *automatically assumed to be infected*, and *must be treated* (epitreatment). Cultures should be obtained, but treatment must not wait for the results. Treatment must be expeditious because some contacts will continue sexual activity and infect new partners, some will not return for culture results, and some will go on to develop complications. Epitreatment is normally arranged by reporting the patient to the preventive medicine technician or the county health department. They will interview the patient, in strictest confidence, and arrange for treatment of contacts. The name of the patient is not divulged to the contact. *Reporting of gonorrhea is mandatory.*

Pelvic Inflammatory Disease (PID)

Pelvic Inflammatory Disease (PID) is *the* major cause of gonococcal morbidity, with 10 to 20 percent of endocervical gonorrhea developing into PID. The first PID episode carries a 15 percent chance of sterility. Each subsequent PID episode predisposes to future episodes; three or more episodes yield a 75 percent chance or greater of sterility. Traditionally thought of as a complication of gonorrhea, PID can be caused by multiple organisms, often by a mixed flora, especially in later episodes. *Chlamydia trachomatis*, an especially important pathogen, can produce most of the complications caused by gonorrhea, including sterility. Intrauterine contraceptive devices (IUD) increase the risk of PID three to nine times; they should be removed once the patient has received a dose of antibiotics. In six percent of first episode PID, surgery is required (generally a D & C); 54 percent of third episode PID requires surgery, generally a hysterectomy.

Symptoms usually occur at the next menstrual period after infection, and can include vaginal discharge, intermenstrual bleeding, menorrhagia, urinary tract infection (UTI) symptoms, and especially lower abdominal pain. Physical exam classically reveals pain on cervical motion (“chandelier sign”), purulent cervical discharge, uterine/adnexal tenderness, and perhaps palpably enlarged tubes and a mass. Only one-third have an elevated temperature; only one-half have an elevated white cell count. *Mild Cases of PID are common, but have the same bad prognosis.*

Endocervical and rectal cultures for gonorrhea are mandatory, but treatment should begin at

once. Chances of infertility double if treatment is delayed a week. When in doubt, err on the side of overtreatment, using an outpatient regimen. Hospitalization is required if:

1. Diagnosis is uncertain.
2. Surgical emergencies must be ruled out.
3. Pelvic abscess is suspected.
4. Illness is severe.
5. Patient unlikely to follow or tolerate an outpatient regimen.
6. No response to outpatient regimen after 48 to 72 hours.
7. Follow-up after 48 to 72 hours of outpatient treatment is not possible.

Epididymo-Orchitis

Epididymo-orchitis is the male equivalent of PID, and requires 10 to 14 days treatment. Under age 35, nearly all treatable cases are due to *Neisseria gonorrhoeae* or *Chlamydia trachomatis*. (Some cases occur which are probably due to a virus.) Treat as for PID. In homosexual men, particularly those practicing rectal intercourse, epididymitis is often due to gram-negative rods, usually *Escherichia coli*. In addition to a Gram stain, a clean catch midstream urine culture is helpful diagnostically. The gram-negative organism can be treated with an appropriate antibiotic, although the organism is sometimes resistant to ampicillin. In some cases surgical exploration and drainage or orchiectomy is required.

Disseminated Gonococcal Infection (DGI)

Disseminated Gonococcal Infection (DGI) is, perhaps, the most common cause of acute infectious arthritis in young adults, and occurs somewhat more often in women. Menstrual periods and pregnancy are the most common risk factors, presumably because changes in the endocervical lining allow dissemination. Patients are usually asymptomatic at the primary site, both when first seen and by history. Less than three percent of gonorrhea develops into DGI; 88 percent of cases are due to very penicillin-sensitive strains, but cases due to PPNG have occurred. Most (69 percent) have arthropathy/tenosynovitis plus dermatitis; 22 percent have arthropathy alone; seven percent dermatitis alone.

Sexually Transmitted Diseases

Classically, DGI begins with dermatitis (5 to 30 petechial-pustular lesions on an erythematous base, mostly on the extremities), plus an asymmetrical polyarticular arthralgia/tenosynovitis which may involve wrists, knees, ankles and small joints of hands and feet. Symptoms may be migratory, and small, usually sterile, effusions may be seen. Blood cultures within five days of symptoms are positive in 20 to 50 percent of cases, especially if skin lesions are present. Skin lesions are positive (Gram stain and/or culture) in less than 10 percent of cases. After seven days, the patient usually presents with a classic “hot joint” (monoarticular pyogenic arthritis), which will be Gram stain or culture positive 25 to 50 percent of the time. This “textbook” progression may not always be seen. Men should have urethral and pharyngeal cultures, and, if homosexual, rectal cultures. Women should have endocervical, rectal, and pharyngeal cultures.

Hospitalization is indicated if:

1. Patient is unreliable or won't tolerate an outpatient regimen.
2. The diagnosis is uncertain.
3. There is a purulent joint effusion.
4. Other complications.

Open drainage of joints is rarely required except for the hip. However, frequent percutaneous aspiration and saline irrigation of the joint may be beneficial, especially for a septic joint that has not begun to respond after 24 hours treatment. Joint irrigation with an antibiotic is not required, and is contraindicated because it may produce a chemical synovitis.

Pharyngitis

The prevalence of gonococcal pharyngitis in STD clinics varies from 0.2 to 1.4 percent in heterosexual men, 3 to 11 percent in women (although some studies show 5 to 47 percent), and 5 to 25 percent in homosexual men. Transmission *from* the pharynx is probably infrequent but clearly does occur.

As with all pharyngitis, clinical appearance is not diagnostic. Gram stains are not useful due to nonpathogenic *Neisseria* species normally found in the mouth. Cultures are expensive and time consuming due to the need for special sugar fermentation studies to speciate the organism. Criteria for obtaining a gonococcal throat culture include anyone symptomatic with pharyngitis who falls into any one of the following groups:

1. Homosexual male.
2. Has accompanying genitourinary symptoms.
3. Had recent sex contact with someone who had gonorrhea.
4. Continues symptomatic after treatment for "strep throat."

In addition, *asymptomatic* patients from high risk groups (women or homosexual men with multiple partners, especially if practicing fellatio), as well as DGI patients, should have pharyngeal cultures.

Proctitis.

Gonococcal proctitis occurs in 36 to 44 percent of women with endocervical gonorrhea, usually due to penile-perineal contact. Rectal intercourse is not required. Among homosexual men, 45 percent had rectal gonorrhea; over 90 percent admitted to receptive rectal intercourse. Most cases are asymptomatic, although minor symptoms occur such as pruritis, mild discomfort (pain, pressure, fullness), mild diarrhea or discharge, or mucous on stools. Such symptoms may be more common than realized but often are not volunteered by the patient. Significant proctitis (tenesmus, purulent discharge, bleeding) is seen in three to ten percent of cases.

Gram stain is positive in 30 percent of cases. Cultures provide definitive diagnosis, although multiple cultures may be required. Anoscopy may show nonspecific findings (mucous, generalized edema, ulcerations), or be normal.

Nongonococcal Urethritis (NGU)

Mucopurulent Cervicitis

Introduction

Nongonococcal urethritis (NGU) is the preferred term, rather than the obsolete "nonspecific urethritis" (NSU). NGU includes the entity postgonococcal urethritis (PGU), which represents a dual infection with gonorrhea (two to eight days incubation) and the agents of NGU (10 to 20 days incubation). NGU is a sexually transmitted disease due to *Chlamydia trachomatis* (40 to 50 percent of cases), *Ureaplasma urealyticum* (30 to 50 percent), or an unknown third agent. Other STD pathogens *rarely*, if ever play a role.

Sexually Transmitted Diseases

Epidemiology

In the U.S., NGU is about 2.5 times as common as gonorrhea. In overseas military populations, gonorrhea is slightly more common, but the incidence of either may reach several hundred per 1000 men per year. One aircraft carrier study demonstrated that, *statistically*, each crew member had at least one case of urethritis during a year's cruise. The analogous disease in women is chlamydia endocervicitis, but it may also present as the acute urethral syndrome or dysuria-pyuria syndrome.

Genital Infection

Genital infection with chlamydia appears to be inversely related to age, and positively correlated with the number of sex partners. Sexually active women less than 20 years of age have an infection rate two to three times higher than those over 20 years. Similarly, the rates of urethral infection among teenage males are higher than those for adults. Urethral chlamydial infections among homosexual men are about one-third the prevalence seen in heterosexual men, but four to eight percent of homosexual men seen in STD clinics have rectal chlamydial infections. Two studies of young, sexually active men, have demonstrated that about 11 percent of them are asymptomatic chlamydia carriers.

Approximately 70 percent and 36 percent, respectively, of female sex partners of men with confirmed chlamydia urethritis or confirmed gonococcal urethritis have chlamydia isolated from the endocervical tract. Of men who are sex partners of women with confirmed chlamydial infection, 25 to 50 percent have chlamydia isolated from the urethra. Many of these contacts are asymptomatic. Approximately 15 to 30 percent of heterosexual men with gonococcal urethritis have a simultaneous infection with chlamydia.

Clinical Course

The incubation period for NGU is 10 to 21 days, however up to 30 percent of urethral chlamydial infections have few or no symptoms. It is not known how long the organism may persist in men, but in untreated women, chlamydia have persisted up to 18 months. About one-third of treated NGU cases recur within six weeks.

NGU is not due to alcohol, caffeine (coffee, tea, cola), highly spiced foods, physical strain, masturbation, allergies, "toxin," or sexual over- or under-indulgence. Therefore, there is no need to restrict any of these things when treating NGU. Some patients report their symptoms get worse after drinking beer. This is probably a placebo effect; however, if patients think beer (or anything else) makes their symptoms worse, they should reduce their beer intake.

Classically, NGU symptoms develop slowly with the patient complaining of mild dysuria or meatal itching, often only on arising or in the morning. The discharge is usually clear and mucoid, and may also be present only on arising. There may be no overt discharge, or only meatal crusting or stained underwear.

In contrast, classic gonorrhea presents abruptly, with severe dysuria and a copious purulent discharge. However, the spectra of presentation of these two entities overlap, and *either may mimic the other*. All urethritis patients should be evaluated with an urethral Gram stain and culture for gonorrhea.

Diagnosis

Specific diagnostic tests for chlamydia (and ureaplasma) are not ideal, and generally are unavailable outside of medical centers or specialty clinics. However simple tests (e.g., a Gram stain) in an appropriate clinical presentation, are reasonably useful, especially in men. Diagnosis usually begins with a history of sexual exposure, plus symptoms of dysuria with or without an overt discharge.

The key diagnostic test is demonstration of urethral leukocytes, in the absence of gonorrhea. Either of two diagnostic criteria may be used:

1. Microscopic examination of spun sediment from the *first 10 to 15 ml* of voided urine. More than 10 to 15 WBC per high power field (450X) is diagnostic.
2. Microscopic examination of an urethral Gram stain. An average of more than 4 white blood cells (WBC's) per oil field (1000X) is diagnostic, taking the mean count of 5 fields.

It is important to use only the *first 10 to 15 ml* of urine, (i.e., just enough to rinse out the urethra). The usual "clean catch midstream" (i.e., bladder, urine) is not appropriate. Gonorrhea must be ruled out by failure to detect gram-negative diplococci (GNDC) on Gram stain, and by a negative gonococcal culture (if available). An urethral Gram stain for gonorrhea will be falsely negative in 10 to 15 percent of cases. Despite this, a Gram stain negative for GNDC is sufficient grounds to presumptively treat the patient for NGU. If the gonococcal culture subsequently is positive, treatment should be altered to treat both chlamydia and gonorrhea.

These diagnostic criteria are somewhat arbitrary, and may be too conservative. One study found 24 percent of NGU patients with an urethral discharge and dysuria had less than or equal to 4 WBC per oil field. For this reason, it is acceptable to diagnose NGU on the basis of any sort

Sexually Transmitted Diseases

of overt discharge, without quantification of urethral WBC. *However since gonorrhea always has to be ruled out*, and it takes only a few seconds to quantitate the WBC seen on Gram stain, it is more efficient for the lab to automatically quantitate the WBC on all urethral Gram stains, and report the results as “greater than 4 WBC” or “less than or equal to 4 WBC.” The overt discharge criterion simply allows for diagnosis and treatment even if the quantitative WBC criterion cannot be met.

Patients who complain of dysuria but have no overt discharge, no GNDC on Gram stain, and less than 4 WBC per oil field should generally not be treated. They should refrain from sexual intercourse, and return in two to three days for reevaluation or whenever they have a discharge. This is best done on arising in the morning before urinating. If these tests, including gonococcal cultures, remain negative, supportive symptomatic treatment may be all that is necessary. A trial of tetracycline can be considered, but often eventuates into repeated, prolonged, “trials.”

Asymptomatic sexually active patients may also be evaluated (“conscience check”). Evaluation should probably wait until at least seven to ten days after the last sex contact, due to the prolonged incubation period of NGU. Because NGU may incubate up to 21 days, and gonorrhea occasionally up to 18 days, asymptomatic patients should, ideally, be checked, or rechecked, three weeks after their last sex contact. Patients should have both a Gram stain, and a culture for gonorrhea. Any positive findings should be treated the same as for a symptomatic infection. Since up to 10 percent of young sexually active men may be infected asymptotically with chlamydia, an alternative to a “conscience check” might simply be empirical treatment.

Mucopurulent Cervicitis

The presence of mucopurulent endocervical exudate suggests cervicitis due to chlamydial or gonococcal infection. Criteria for presumptive diagnosis include any of the following:

1. Mucopurulent secretions from the endocervix which may appear yellow or green when viewed on a white cotton-tipped swab (positive swab test). (Inspect outside the vaginal vault, against a dark neutral background.)
2. Greater than 10 polymorphnucleocytes (PMN) per oil (1000X) field in a Gram-stained smear of endocervical secretions.
3. Cervicitis, determined by cervical friability (bleeding when the first swab culture is taken) and/or by erythema or edema within a zone of cervical ectopy.

If *N. gonorrhoeae* is found on Gram stain or culture of endocervical or urethral discharge, treat for uncomplicated gonococcal infection. If *N. gonorrhoea* is not found, treatment should be for chlamydial infection.

Immunodiagnostic Tests

Chlamydiazyme (Abbott) is an enzyme immunoassay (ELISA), which is compatible with equipment used for several other ELISA viral assays commonly available. It is about 67 to 90 percent sensitive, and 92 to 97 percent specific. *Microtrak* (Syva) uses a fluorescein-conjugated monoclonal antibody, and is more than 90 percent sensitive and more than 98 percent specific. However it requires a fluorescence microscope, and lesser sensitivities are seen with less than optimal specimens. Technicians who are not experienced often over-read or under-read the Microtrak tests. Both tests are significantly less sensitive in asymptomatic patients.

Treatment regimens may be found in Appendix A.

Retreatment of "Treatment Failures"

In general, tetracyclines work best, and failures are not due to tetracycline resistance. Because NGU is a sexually transmitted disease, sex partners must be treated. It is useful to approach treatment failures systematically, as outlined below. Nevertheless up to 30 to 40 percent of cases may recur, especially those in which *Chlamydia trachomatis* is not involved. The reason for this is not clear, but may involve a latent or "dormant" state. Tetracycline is the retreatment drug of choice.

Most true treatment failures, as opposed to relapses, are due to:

1. Failure to treat the sex partner or failure to overlap partner's treatment by several days.
2. New infection from a new partner.
3. Patient fails to take the medication.

Other considerations:

1. Some patients respond better to doxycycline, probably due to better compliance.
2. If two to three courses of tetracycline fail, try erythromycin.

3. Some patients are infected with tetracycline-resistant ureaplasma. These patients have no symptomatic relief while on tetracycline, as opposed to the more common scenario of reduced symptomatology while on tetracycline, with *symptoms recurring when tetracycline is stopped*. Patients who get no relief while on tetracycline should be treated with erythromycin.

4. Rarely, *Trichomonas vaginalis*, a common cause of vaginal infections, may be the etiologic agent. If repeated courses of antibiotics fail, consider trying metronidazole (Flagyl), 2 grams p.o. as a single dose. Warn patient not to drink anything alcoholic for two days afterwards, to avoid a possible Antabuse-like reaction. The sex partner should also be treated with metronidazole.

5. Occasionally, herpes simplex virus, (HSV), may cause NGU. Usually there are characteristic external lesions to help identify the agent (although dual infections occur), and the severity of dysuria is out of proportion to the usually mild, often mucoid, discharge. Patients who get no relief, temporary or long term, from tetracycline or erythromycin, should have a urethral swab culture for HSV. This should be done as soon as possible after the onset of symptoms, since viral shedding may only last a few days.

6. Other organisms have been alleged to cause urethritis in men (e.g., *Staphylococcus aureus* or *Staphylococcus saprophyticus*), but good evidence supporting this is nonexistent. Some organisms (e.g., yeasts, *Gardnerella vaginalis*), are known to be involved in STD in women, and can “ping pong” between women and male partners. It is very doubtful that these agents actually produce symptomatic urethritis in men, although they do occur in transient carrier state.

Follow-up and Long-Term Treatment

Because potentially serious pathogens are rarely isolated after an initial course of tetracycline, long-term follow-up and management are unclear. It is debatable whether patients who remain asymptomatic after an initial course of treatment require any follow-up. In patients whose symptoms and discharge or urethral WBCs persist or recur after one to two courses of tetracycline plus a course of erythromycin, the course is less clear. Some may benefit from a four to six week course of doxycycline, 100 mg b.i.d.

Patients who do not respond to this regimen should have urethral herpes cultures (when symptomatic) and a systematic evaluation for prostatic infection, using the three bottle technique of Meares and Stamey (1968). These maneuvers, however, are often negative. Such patients should be considered for urologic referral to rule out possible strictures, foreign bodies, or intraurethral lesions. Unless significant lesions are found, it is probably better to simply observe the patient rather than blindly treating with antibiotics.

Because of a known high recurrence rate, as well as the possibility of a new or missed diagnosis of gonorrhea, the patient should be reevaluated every time for WBCs in the urine or urethra, and cultured for gonorrhea. If there are no, or insufficient, WBCs in the urine or Gram stain, and the patient gives no history of a recurrent urethral discharge, he is probably simply taking longer than usual to resolve his symptoms. Antibiotics are not required; pyridium might be considered. Observe for two to four weeks and then reevaluate if still symptomatic.

In some patients there comes a time when it is necessary to be reassuring and supportive, but to play down the workup and treatment aspects of the disease. These patients have, perhaps, developed a "genital neurosis" and are focusing on minor nonspecific signs and symptoms. Excessive "milking" of the penis may prolong the symptoms due to mechanical trauma. The patient should be cautioned not to do this.

Complications of NGU

Untreated patients carry a small, (less than one percent), risk of chlamydial epididymitis. Chlamydial epididymitis should be treated with the same dose of tetracycline or doxycycline, however treatment should be extended for a total of 10 days. Untreated men are also at a low risk for developing Reiter's syndrome, which may be seen at the time of initial presentation, or develop several weeks after the initial case of urethritis.

Genital Herpes Simplex Virus

Introduction

HSV-1 (usually, but not exclusively, associated with herpes labialis or "fever blisters"), and HSV-2 (usually associated with genital lesions) are immunologically distinct, but for most practical purposes, clinically identical. Either type can establish itself on any mucous membrane, or in any skin break. However, genital HSV-1 has a lower rate of recurrences, 55 percent, compared to 88 percent with HSV-2. Also, prior labial HSV-1 ameliorates the severity and duration of first episode genital herpes (so called "nonprimary genital herpes"), regardless of which virus is causing the genital lesions.

The appearance of genital HSV in a monogamous relationship is sometimes equated with infidelity. However this can develop in at least three other ways: (1) Oral sex when the oral partner has oral herpetic lesions. (2) Genital sex play involving a herpes infected finger (herpetic whitlow). The latter is an occupational hazard for medical and dental personnel. (3) A woman may asymptotically carry, and shed, HSV from her cervix, subsequently infecting her partner.

Sexually Transmitted Diseases

Up to 80 percent of adults may have HSV in their trigeminal ganglion, a legacy of an often unrecognized childhood infection. Of these, five percent are shedding HSV in their mouth, asymptotically, at any given time. HSV has been isolated from the cervix of two to eight percent of women attending STD clinics, often without symptoms, and from 0.25 to 1.5 percent of private gynecologic patients. Such shedding is brief, (mean 3.2 days; range one to five days), and titers are lower, about 1/1000 those of symptomatic cases.

Clinical Course

Primary genital HSV incubates two to 20 days, usually about six days, sometimes up to six weeks. There is a prodrome of about four days of dysuria, itching, paresthesias, pain, and in women, a variable vaginal discharge. Symptoms then increase, and small papules briefly appear almost anywhere in the genital area. These rapidly evolve into vesicles (“water blisters”). Within 24 to 48 hours these become pustular, then form ulcerative lesions, which last four to 15 days. Tender inguinal adenopathy appears during the second and third week, which may be prolonged, and may even outlast the ulcers.

Individual lesions are usually 2 to 5 mm, shallow, flat, painful, without induration. Some patients have painless lesions. New lesions continue to be formed in 75 percent of primary, first episode cases. Crusting and scabbing precedes re-epithelialization on dry exposed skin. However lesions which develop on mucosal surfaces or moist cutaneous surfaces (e.g., under the foreskin or in the depths of the labia) never develop crusts. Such lesions have such transient vesicles. that they are rarely seen. Instead, those lesions appear as ulcers from start to finish. Lesions usually require two to three weeks to resolve.

Complications

Primary HSV genital infections have a high frequency of systemic or extragenital manifestations. Fever, headache, malaise, and myalgias are seen in 39 percent of men and 68 percent of women. They peak within the first four days after lesion onset, then resolve over the remainder of the first week. About 19 percent of patients with primary genital HSV have symptomatic HSV pharyngitis.

Dysuria is reported by 83 percent of women and 44 percent of men with primary HSV. Urethral discharge is usually clear and mucoid, has 5 to 15 WBC/oil field, and is symptomatic far out of proportion to the discharge seen. Extragenital lesions occur in 26 percent of women and 10 percent of men, with primary genital HSV, probably due to autoinoculation.

Stiff neck, headache, and photophobia, with or without fever, occur in 36 percent of women and 13 percent of men with primary HSV. In some cases, hospitalization with supportive treatment for aseptic meningitis is required. HSV encephalitis has not been reported in this setting, and HSV meningitis associated with recurrent genital HSV is rare. Treatment is not required, however IV or p.o. acyclovir can markedly reduce meningeal symptoms. Sacral paresthesias, constipation, and urinary retention requiring catheterization occur rarely.

Recurrent Infections

Recurrences may be precipitated by a variety of factors (e.g., stress, menses, sunlight, local trauma, sex, fever). Many recurrences, however, have no precipitating factors. Conflicting studies show both a 50 percent reduction in recurrence rates after four to five years, and no reduction.

In about 50 percent of patients, a prodrome occurs, anywhere from a few hours to two days before the recurrence. This may consist of a hyperesthesia or dysesthesia (tingling, burning, or numbness), or sometimes an aching neuralgic pain in one of the sacral dermatomes. The duration, nature, and location of these premonitory symptoms may vary from recurrence to recurrence, even in the same patient.

The frequency, duration, and severity of recurrences are highly variable, even in the same patient. In general, recurrences are milder and shorter. Constitutional symptoms are infrequent in recurrent HSV, occurring in 5 percent of men and 12 percent of women.

Pregnancy

Overall frequency of neonatal HSV is about 1 in 7500 live births, or about 500 cases per year. The major source of infection is viral shedding in the genital tract, during delivery. Vaginal delivery during primary infection may carry a 50 percent risk of neonatal infection, with significant morbidity and mortality, compared to five percent with recurrent infection. However up to 70 percent of infected neonates come from mothers who are asymptomatic at delivery. Overall, a woman with a past history of genital HSV, but no active lesions at delivery, has a 1:1000 chance of infecting the baby.

Cervical Cancer

Women with a history of genital HSV are six times as likely to develop cervical carcinoma, although it is debatable if HSV is oncogenic per se, or simply a marker for cervical carcinoma. Pap smears are mandatory at least yearly.

Diagnosis

Vesicular lesions, “water blisters,” are so characteristic of genital HSV, they are essentially diagnostic. Multiple bilateral lesions are characteristic of primary HSV, whereas recurrences may have a single or a few lesions. At presentation, the vesicles may have become pustular or ulcerative, often coalescent, or crusted if late in the course.

Individual lesions are usually flat, shallow, nonindurated, have minimal erythematous rim or margin, and are generally, but not always, painful. *All* genital ulcers require periodic serologies over three months to rule out syphilis, as well as a darkfield exam if available. Older lesions may not be particularly diagnostic in appearance. Historical information pointing toward a diagnosis of HSV includes vesicular lesions early in the episode, prior episodes of similar lesions at or near the same site, and a sex partner with genital HSV.

Laboratory diagnosis is by tissue culture, or demonstration of giant cells and intranuclear inclusions on Tzanck prep or Pap smear (40 percent sensitive). (A Tzanck prep can be done by unroofing a lesion with a sterile scalpel blade, blotting the fluid, and then gently scraping the base of the lesion. A drop or two of fluid is placed on a glass slide, and allowed to dry. It is then stained with Wright or Giemsa stain, the same as for a peripheral smear. Viewed under the microscope, multinucleated giant cells, with intranuclear inclusions, constitute a positive smear.) Laboratory tests are less sensitive the older the lesion, and less sensitive in recurrent lesions.

Therapy

Basic Therapy. Basic therapy consists of keeping the lesions clean (gently) and dry. Tight Atting nonporous clothing should be avoided. Periodic cool Burow’s solution or sitz baths may be helpful in severe cases. For women in whom urination is painful, due to spillage of urine over lesions, urinating through a funnel or toilet paper core may help. Alternatively, urinating while seated in a bath tub of warm water may help. Topical salves and ointments (e.g., lidocaine) should not be used. Applying them risks herpetic whitlow (unless the finger is covered), and the ointment acts as an occlusive dressing which promotes viral propagation.

Other Remedies. Myriad other remedies have been proposed: Topical antivirals (vidarabine, idoxuridine), topical 2-deoxy-D-glucose, “nutritional therapy” (e.g., L-lysine), topical lipid solvents (ether, acetone, chloroform), nonoxynol-9, photodynamic dyes, vaccines (small pox, polio, influenza, BCG), and interferon. None is effective. Many are painful or expensive; some are dangerous.

(ACV) (*Zovirax, Burroughs Wellcome*). ACV does not eliminate HSV, and there is no evidence prophylactic use of any form prevents an uninfected person from acquiring HSV. It probably does not prevent an infected person from transmitting HSV to an uninfected partner.

Topical ACV provides some symptomatic relief for prolonged, very painful lesions. Viral shedding is also shortened, and lesions heal more rapidly. It is not effective, however, for herpes labialis (fever blisters). It is much less effective against recurrent genital lesions, largely because the latter tend to be transient and mild, leaving little disease for ACV to act on. Topical ACV may cause transient burning. It has largely been supplanted by the oral form.

Oral ACV (200 mg, five times per day, for 7 to 10 days), initiated within six days of onset of lesions, significantly reduces the duration of viral shedding and new lesion formation in primary HSV, and reduces severity and duration of symptoms. Results are less effective with recurrent disease, although this can be improved by giving patients ACV ahead of time, and instructing them to take it at the first appearance of lesions, or premonitory paresthesias.

Indications for oral ACV are primary (first episode) genital HSV and "severely painful" lesions. It may also be indicated for complicated infection (e.g., aseptic meningitis, inability to void), and HSV in significantly immunocompromised patients. In many of these latter cases however, the symptoms will be severe enough to require hospitalization and IV ACV.

ACV is *not indicated* for recurrent HSV, unless the lesions are prolonged or painful. The dose is 200 mg p.o., five times per day, for 5 days. It is not indicated for prophylaxis or for fever blisters. Its use for varicella zoster (shingles) is questionable, since oral ACV may not achieve adequate serum levels for this virus.

Patients with *frequently recurring* genital HSV, usually defined as six or more recurrences per year, may benefit from *chronic ACV* (200 mg. two to five times per day). This regimen eliminates or greatly reduces the number of recurrences, but when stopped, episodes recur at their usual frequency. Some patients experience a transient rebound increase in recurrences. Chronic ACV is only approved for periods of six months, however this will probably be extended to one year in the near future.

The safety of systemic ACV for the treatment of pregnant women has not been established. The suppressive regimen is contraindicated in women who may become pregnant.

Prevention - Condoms are effective *in vitro*, but have limited efficacy *in vivo*. In addition to the usual limitations, condoms cannot cover all the areas where lesions may exist or be acquired.

Sexually Transmitted Diseases

Education - Counseling patients about the disease is highly important, and should include emphasis on how infectious HSV is, even during recurrences. Sex should be avoided from the earliest lesions or premonitory symptoms, until the lesions are completely healed. The effective treatments should be set forth, and the patient encouraged not to waste time and money chasing after unproven remedies. Women need to be told of the risk of cervical cancer and the need for annual Pap smears, as well as to tell their obstetricians of any history of HSV infection or exposure, when they become pregnant.

Supportive counseling is needed, since for many patients this will be their first chronic recurring illness. For nearly all patients, the disease carries a certain stigma, and has the potential to disrupt interpersonal relationships. Discussing the issues, giving a patient a chance to ventilate -anger is often a significant reaction, making sure he or she understands the disease, perhaps encouraging the patient to join a local support group - all help. Often, this process requires repeated visits.

Syphilis

Introduction

Statistically, syphilis is a “minor” STD, however the steady decline of many years was markedly reversed in the U.S. in 1987, with several states and cities, including Florida, San Diego, and Los Angeles, reporting rates of primary and secondary syphilis many times greater than the previous year. There has been, not unexpectedly, a parallel increase in congenital syphilis. The reasons for the increase are speculative, but include the recent change in these areas to the use of spectinomycin as the drug of choice for gonorrhea (spectinomycin is not active against syphilis), and increased promiscuity among “crack” users, who trade sex for drugs. Information on syphilis rates outside the U.S. is limited, but the same pattern seems to be emerging there also.

Stages of Syphilis

Primary Syphilis. Primary syphilis occurs when *Treponema pallidum* penetrates through mucous membranes or small breaks in the cornified epithelium. Incubation is 10 to 90 days, with an average of three weeks. The typical chancre is solitary, indurated, painless, smooth-based, and heals in three to six weeks. Chancres are usually found on the genitalia, at the rectum, or in the mouth. Atypical lesions are common, including extragenital lesions. Secondarily infected and traumatized lesions may be painful. Intraurethral lesions frequently cause dysuria and watery discharge similar to that of NGU. Chancres usually last three to eight weeks, and heal leaving a thin atrophic scar. In reinfection syphilis, patients may have sufficient immunity to alter the clinical presentation of the disease; the chancre may not appear.

Regional *lymphadenopathy* is associated with primary syphilis, with nodes usually being nontender, nonerythematous, round, rubbery, and freely moveable. Initially, the lymphadenopathy is usually unilateral, but if untreated, progresses to bilateral disease. Systemic signs (fever, malaise, pharyngitis) may also occur.

Darkfield examination may reveal spirochetes compatible with *Treponema pallidum*, but the test may be unavailable, or falsely negative due to topical or oral antibiotics, washing the lesions, or inadequate numbers of organisms. Darkfield examination of intraoral lesions is not recommended due to the presence of harmless commensal spirochetes which cannot be distinguished from *T. pallidum*.

Serological tests (VDRL, RPR, FTA-ABS, MHA) may be negative early in the course of disease. Up to 25 percent of patients have a negative VDRL when the chancre first appears. If serology is negative, the test should be repeated at one week, and at one and three months. Negative serological tests after three months, the maximum incubation time, essentially rule out syphilis.

Secondary Syphilis. Secondary syphilis occurs within six months of exposure, usually within six to eight weeks, often overlaps the chancre, and may recur if untreated. Skin lesions can be extremely variable, but if generalized are symmetrical and nonpruritic. Vesicular lesions are not seen in syphilis (except sometimes in congenital syphilis). Lesions may be localized, including mucous membranes or specific organs (iritis, hepatitis, meningitis). Skin lesions may be macular, papular, follicular, or squamous. Maculopapular lesions are the most frequently seen, followed by papular, macular, and annular papular. Blacks often have annular lesions with a central clear area and a raised border. Split papules may be found at the mouth angles or in the nasolabial folds. Inside the mouth or on the tongue may be found *mucous patches*, grayish, slightly raised, flat lesions. If scraped away, they leave a shallow ulcer. Intertriginous and anogenital areas may produce *condyloma lata*, flattish, moist raised lesions. They must be distinguished from venereal warts.

Secondary syphilis is a *systemic* disease, with a spirochetemia. Patients may complain of pruritis, pharyngitis (a notoriously unappreciated sign), weight loss, fever, myalgias or arthralgias. There is a generalized lymphadenopathy, with the nodes appearing similar to those of primary syphilis. Patchy alopecia may be seen (often it is subtle), or the patient may complain of excessive hair loss. Syphilitic hepatitis is common, with the alkaline phosphatase characteristically elevated out of proportion to other enzymes.

Neurological Manifestations in Secondary Syphilis. Spirochaetal CNS seeding is common in secondary syphilis. However, most cases are neurologically asymptomatic, do not require a lum-

Sexually Transmitted Diseases

bar puncture (LP), and respond well to standard therapy (i.e, 2.4 million units of benzathine penicillin G (Bicillin)). Some cases do have neurological symptoms, most commonly meningitis, uveitis (eye pain, blurred vision), hearing loss, other cranial nerve palsies, or transverse myelitis. These symptoms often respond to a single dose of Bicillin, but may recur. The VDRL/RPR, however, may revert to negative and stay negative, obscuring accurate diagnosis of the recurrence.

For these reasons, secondary syphilis with neurological manifestations should be managed as neurosyphilis (see Appendix A). Many infectious disease experts feel strongly that only 10 days of IV penicillin is acceptable for documented neurosyphilis. However, the three dose benzathine regimen is effective in about 90 percent of cases. None of the three regimens has been adequately studied. In managing cases of secondary syphilis with neurological manifestations, the following approach is suggested. Mild symptoms, which may not be due to syphilis (e.g., a mild, vague headache) can be treated with three doses of benzathine penicillin. More severe symptoms, or symptoms with objective manifestations (e.g., cranial nerve palsy) should be treated with 10 days of IV penicillin. (The procaine penicillin regimen, Regimen 2, is for situations where IV penicillin is not available.) If in doubt, the IV penicillin regimen should be used.

The need for medical evacuation can only be determined on a case-by-case basis. Cases which respond well to treatment, especially if mild, probably do not need medical evacuation. They should be seen by an internal medicine or infectious disease consultant at the first opportunity. Cases which have not begun to respond, after a course of therapy, or whose response is unsatisfactory, should be MEDIVACed to an infectious disease specialist as soon as practicable. Cases involving only eye or ear symptoms may be MEDIVACed to an ophthalmologist or otolaryngologist, respectively.

Penicillin allergic patients with neurosyphilis should be managed by an expert in infectious diseases. If this cannot be done expeditiously, the patient should be started on tetracycline 500 mg p.o. Q6H, for 30 days, while undergoing medical evacuation. Evacuation should be carried out as soon as practicable. If the patient begins to respond to tetracycline, or the neurological symptoms were mild or not clearly related to syphilis, it may be appropriate to complete the course of tetracycline without medical evacuation. The decision has to be made on a case-by-case basis, however data as to the efficacy of tetracycline are very limited. It is not considered the drug of choice. The patient should be monitored closely in an attempt to assure compliance in taking tetracycline for the full 30 days. If a decision is made to complete a course of treatment without medical evacuation, the patient should be monitored closely thereafter for recurrent disease. He or she should also be evaluated by an internal medicine or infectious disease consultant, or ophthalmologist or otolaryngologist, at the first available opportunity.

In untreated patients, the clinical lesions of secondary syphilis heal within four to 12 weeks, including negative darkfield examinations and CSF findings. Up to 25 percent of patients may have one to three relapses, generally briefer and milder, for up to a year.

Essentially all patients with secondary syphilis have a positive serology, but the rare (about 1 in 1000) case exhibiting the "*prozone phenomenon*" may give a false-negative. This results from extremely high antibody titers in the patient's serum, which overwhelm the antigen in the test system. If the VDRL is negative in a patient highly suspected of secondary syphilis, the test should be repeated with the lab chit marked "dilute to rule out prozone phenomenon."

Latent Syphilis

In latent syphilis there are no clinical signs or symptoms. It is a *serological diagnosis*. This does not imply absence of disease progression; approximately one-third of such patients develop clinical tertiary syphilis if untreated. Latent syphilis is divided into *early latent* (primary or secondary syphilis, or exposure to confirmed syphilis, within the past two years) and *late latent*. Patients with a positive serological test and a negative past history for syphilis infection, exposure, or serology should automatically be classed as *late latent* if they have been sexually active for over two years.

Neurosyphilis

Neurosyphilis may be asymptomatic, manifested only by an abnormal cerebrospinal fluid (CSF). Diagnosis is on the basis of greater than or equal to five mononuclear cells, a protein over 40, and a positive CSF VDRL. The diagnostic usefulness of the CSF FTA-ABS is debated, but is generally felt to be uncertain. The cell count is the most reliable indicator of disease activity and therapeutic response. The CSF VDRL should fall as active disease is treated, but old burnt-out syphilis (or syphilis treated late in its course) may show a stable low titer (*serofast*). In degenerative tabes dorsalis 15 to 20 percent have a negative CSF VDRL.

Syphilis During Pregnancy

Syphilis during pregnancy may have devastating consequences for the fetus or infant. Consult the references in the bibliography and obtain gynecological or infectious disease consultation.

Serodiagnosis

Nontreponemal Tests. Nontreponemal tests are for screening and *quantitative follow-up*. Tests available are the *VDRL* (quantitative), *RPR* (a field test with increased sensitivity and decreased

Sexually Transmitted Diseases

specificity), and the *RPR circle* (quantitative). For any given patient, the titers produced by the different tests correlate, but are not directly equivalent.

Nontreponemal serological tests often have *biological false-positives*. Acute biological false-positives last less than six months, and may be seen in acute febrile illnesses, hepatitis, mononucleosis, viral pneumonia, chickenpox, measles, herpes, other viruses, malaria, *Lymphogranuloma Venereum* (LGV), immunizations - especially smallpox, - and pregnancy, among other causes. Chronic biological false-positives last over six months, and can be seen in autoimmune diseases, immunoglobulin abnormalities, narcotic addiction, aging, malignancy, and leprosy. Biological false-positive titers tend to be low, usually less than 1:8

Even though many of these conditions are common, it is *mandatory* for the physician either to *prove* the test is a false-positive, or *treat* the patient for possible syphilis. False-positive nontreponemal tests can be identified by demonstrating a negative FTA-ABS or MHA. If neither of these is available, the VDRL can be followed to see if it becomes negative, however that is useful only with acute false-positives, and runs the risk of disease progression if the test is truly positive.

Treponemal Tests. Treponemal tests measure antibodies specific for treponemes, using *Treponema pallidum* as the antigen. They have much greater specificity, are costly and technically difficult, and are used for verification of a positive VDRL.

FTA-ABS (fluorescent treponemal antibody absorbed) is the standard. It is reported out as “nonreactive,” “borderline” (needs to be repeated), and “reactive.” In rare cases of diseases such as systemic lupus erythematosus (SLE), herpes, Lyme disease, mononucleosis, autoimmune disease, and possibly pregnancy, the ETA-ABS may be falsely positive. In 80 percent of patients treated *extremely* early in the course of primary syphilis, the ETA-ABS becomes negative within two years. Otherwise the FTA-ABS is essentially positive for life; repeat ETA-ABS tests therefore are not useful for all practical purposes. In many hospitals, the *Treponema pallidum* microhemagglutination (MHA) test is replacing the FTA-ABS. its function and interpretation are the same as the FTA-ABS.

Effect of Treatment on Serological Tests. Treated *primary syphilis* usually becomes seronegative (VDRL) within a year; *secondary syphilis* within two years; *early latent* within four years. Only 44 percent of patients with *late latent* syphilis are seronegative at five years after treatment. The remainder are seropositive for the rest of their lives, usually at titers less than or equal to 18, but occasionally with titers as high as 1:32.

VDRL titer changes are considered significant if there is a two tube (four-fold) dilutional change, or greater. A titer going from negative to reactive-undiluted, or 1:4 to 1:2, or 1:64 to 1:32 therefore, would not generally be considered a significant change.

In recording the syphilis serology result in the patient's chart, *always identify the test* used (e.g., VDRL), and *always give the titer* (e.g., 1:16, or indicate "no titer done"). If the VDRL or RPR is positive, an FTA-ABS should always be obtained to rule out false-positives. If the FTA-ABS or quantitative VDRL are not available, serum should be spun down and stored for such determinations when available. Serum can be kept for several weeks in an ordinary refrigerator, or for several months in an ordinary freezer.

Treatment

Treatment regimens may be found in Appendix A.

In general, successful treatment is indicated by the VDRL titer falling four-fold (two dilutions) or greater, although it may require two to four weeks to *begin* to do this. Depending on the stage of syphilis when treated, the titer will continue to fall for months-to-years, eventually reaching a negative or a low titer, serofast, state. Failure of the titer to fall, or a rise in titer four-fold or greater, indicates a treatment failure.

Persistently Positive VDRL. Patients may have a persistently positive VDRL for four reasons: (1) *Serofast:* The infection has been eradicated by late treatment, or has burnt out, but the VDRL does not return all the way to negative. In such patients the VDRL is positive for life, but usually at titers less than or equal to 1:8. Subsequent tests may show some slight drifting of the titer. (2) *Treatment failure:* This is more likely with erythromycin or tetracycline. (3) *Reinfection.* (4) *Biological false-positives.*

Jarisch-Herxheimer Reaction. The Jarisch-Herxheimer reaction may occur after treatment of any stage of syphilis, but is most likely in *secondary syphilis*. It is manifested by transient fever, malaise, chills, headache, myalgia, and worsening of existing skin lesions. If the patient is incubating secondary syphilis, the reaction may precipitate lesions. The reaction is due to the release of endotoxins by dying treponemes, and subsides within 24 to 48 hours. The reaction may be alarming, but is not dangerous except in some cases of tertiary syphilis, or in the elderly. However, the patient should be forewarned. This reaction is not a "penicillin reaction" or "allergy" (although it must be distinguished from that possibility), it is not a "treatment failure" (even if skin lesions worsen or appear), and it is not a reason either to stop or increase syphilis treatment. It can be treated symptomatically with bedrest and aspirin.

Sexually Transmitted Diseases

Follow-Up. Posttreatment follow-up of syphilis must use a *quantitative VDRL*. *Primary or secondary syphilis* should be checked with a repeat VDRL at one, three, six, nine, and 12 months. *Late latent syphilis* should be checked every three to six months for a second year. *Neurosyphilis* should be checked every three to six months for a third year. The rate and extent of change in the VDRL titer depends on the stage and duration of syphilis at the time of treatment. Patients may be discharged from follow-up at the above times, if the VDRL titer has become *negative* or *serofast* (fixed low titer). If such results are not obtained, the spinal fluid should be examined. If syphilitic lesions have not healed or have reappeared, or if the quantitative VDRL is not decreasing or has increased, active syphilis is still present and requires retreatment.

Case Reporting. All cases of syphilis, regardless of stage, *must be reported* to the preventive medicine technician or other appropriate public health agent when first diagnosed.

Special Problems

Serofast State. Patients who were treated late in their disease, or whose syphilis has “burnt-out,” often become *serofast* (i.e., they will have a life-long positive low titer VDRL). To establish a new diagnosis of syphilis in such patients, the darkfield examination must be positive, or there must be a four-fold increase in the VDRL titer. Serofastness does not mean the patient is immune to reinfection.

Lack of Documented Adequate Treatment. Patients are sometimes seen who have a consistently positive, but stable low titer VDRL extending back over years, but without *documentation of adequate* treatment. Such patients usually do not have active syphilis, but might have minimally active disease. They should be evaluated as to the probability of having neurosyphilis, and the need for an LP. If neurosyphilis is not thought likely, or the LP is normal, such patients should be treated for late latent syphilis.

Limited Laboratory Backup. A patient may present with a suspicious lesion and a negative VDRL. Two options: (1) A reliable patient may be asked to return for a repeat VDRL in one and two weeks. (2) An unreliable patient, or one who will not subsequently be available for retesting, should be treated for primary syphilis. But, the situation must be clearly defined in the patient’s chart (e.g., treatment for suspicious lesion compatible with syphilis; adequate serological testing not available).

In some situations, only an RPR or a nonquantitative VDRL is available, and a false-positive RPR or VDRL cannot be ruled out. Serum should be stored until a quantitative VDRL and an

PTA-ABS can be done. In the interim, patients with clinical evidence compatible with syphilis, or with a history of promiscuous sexual exposure, should be treated for syphilis. "Promiscuous" means any sexual exposure outside a monogamous relationship.

All patients treated for syphilis on the basis of an unconfirmed positive RPR or VDRL should have it *clearly noted in the chart* that the *test has not been confirmed* by an PTA-ABS or MHA. An PTA-ABS should be done at the earliest opportunity, and the results indicated in the patient's chart.

Cross-Reacting Nonvenereal Treponematoses. The nonvenereal treponematoses (yaws, pinta, bejel, or endemic syphilis) all cross-react with the VDRL, RPR, FTA-ABS, and MHA. There is no way to distinguish these cross-reactions, and patients with a past history of nonvenereal treponemal disease plus a positive serological test must be treated as if they have syphilis. These facts must be explained to the patient, and clearly noted in the patient's chart. Follow-up serologies appropriate for syphilis must also be obtained.

Random Positive VDRL. A patient may present with a positive VDRL obtained on the basis of random testing, without any symptoms or prior history of syphilis. The patient may deny any exposure, and the health record may be devoid of any previous serological tests which might allow a determination of how long the patient has been infected. A useful algorithm for evaluating the random positive VDRL is in *Postgraduate Medicine* 1978; 64(3):121. Controversy exists as to the need for spinal taps in such patients. Most infectious disease specialists feel a spinal tap is mandatory for any patient with syphilis beyond the early latent state, or in whom the age of the infection cannot be reliably determined. A minority view maintains a tap is not needed if a careful neurological exam reveals no symptoms referable to the CNS. The patient may then be treated as for late latent syphilis.

Inability to do a Lumbar Puncture. In situations where a spinal tap is indicated but cannot be done, the following options are available: (1) If the patient can be seen within several weeks at a facility which can do the spinal tap, tap and treatment can be deferred until then. (Late latent and tertiary syphilis are rarely infectious except to the fetus in pregnancy.) (2) If such facilities will not be available for several weeks or more, and the patient has no evidence of symptomatic CNS disease, the patient can be treated with the regimen for late latent syphilis. As soon as possible, a spinal tap should be done, and if negative, only routine follow-up for late latent syphilis is necessary. If positive, the patient should be retreated with 10 to 14 days of IV penicillin, followed by three weekly doses of benzathine penicillin IM. (3) In patients presenting with symptoms compatible with neurosyphilis, treatment should be with 10 to 14 days of IV penicillin, followed by three doses of benzathine penicillin. An LP should be done as soon as possible thereafter, and appropriate follow-up provided.

Sexually Transmitted Diseases

Syphilis in HIV-Infected Persons. Several case reports and editorials have pointed out that significant immunosuppression may dramatically alter certain luetic features: (1) patients may be seronegative, even in the presence of a compatible rash; (2) disease progression may be greatly accelerated, developing into neurosyphilis within months; and (3) standard stage-specific treatment regimen may fail. Diagnosis, in some cases, has required biopsy of skin lesions and special stains. The efficacy of even 14 days of IV penicillin has been questioned, raising the specter of “maintenance” antibiotic therapy for syphilis. The significance, representativeness, and validity of these cases have been questioned, but clearly there are grounds for considerable concern.

All cases or suspected cases of syphilis in HIV-infected persons should be referred promptly for infectious disease and internal medicine consultation and management. Cases felt to have neurological manifestations of syphilis, should be managed as neurosyphilis. All syphilis cases should have prompt evaluation for HIV infection, continuing for six months, especially if the manifestations of syphilis seem atypical, severe, or do not respond to treatment. All HIV-infected persons with CNS symptoms should be evaluated for neurosyphilis, among other possible causes.

Chancroid

Chancroid is an ulcerative disease of the external genital organs caused by *Hemophilus ducreyi*, and usually accompanied by inguinal adenopathy, which may suppurate. It is primarily a disease of third world countries although it may be more common in the United States than realized. It is often associated with prostitutes (or highly promiscuous women), and several localized outbreaks have occurred in the U.S. and Canada.

Clinical Disease

A variable incubation period is reported, of 12 hours up to, occasionally, several weeks; however three to seven days is usual. The lesion goes through a macule to papule to vesicle to pustule sequence, however a small painful ulcer is usually the first lesion noticed. This enlarges, becoming irregular and undetermined, with a nonindurated, gray-yellow necrotic “dirty” base. About 40 percent of patients have a single ulcer, with most of the rest having up to five. These may coalesce into a serpiginous ulcer.

Occasionally the ulcer remains pustular, resembling furunculosis. Most lesions in men occur on the prepuce, frenulum, and coronal sulcus, however lesions on the shaft and scrotum are also seen. In women, where they are frequently less painful, the vaginal fourchette and labia majora and minora are common sites. “Kissing ulcers” are traditionally associated with chancroid, however this finding is nonspecific. Any ulcerative lesion can “kiss” where two surfaces are opposed.

About 1/3 of patients develop unilateral (usual) or bilateral tender inguinal adenopathy within one to two weeks of the infection. Lymphadenitis progresses to bubo formation in up to 60 percent, depending on the delay in obtaining treatment. Often, there is an overlying erythema. The untreated bubo eventually ruptures, forming draining sinuses. Although the ulcer, and especially the bubo, may be extremely painful, the patient is usually otherwise asymptomatic. (Several tests suggest that women often or usually have transient, less symptomatic lesions, however it is not clear if this is actually so.) Both sexes may be carriers, but only transiently.

Diagnosis

Diagnosis is largely clinical, in most cases, based on finding irregular, undermined "dirty" ulcers with associated prominent tender adenopathy. On Gram stain, the organisms appear as short gram-negative rods (0.2 x 1.5 microns) forming chains or tracks along mucous strands ("school of fish"). Unfortunately, the Gram stain is severely lacking in both sensitivity and specificity. Especially in inexperienced hands, colonization of ulcers with enteric gram-negative organisms, a frequent occurrence, often leads to a false diagnosis.

Although both LGV and chancroid form inguinal adenopathy, the two can usually be distinguished clinically. The penile lesion in LGV, if noticed, is transient; in chancroid it is prominent. In LGV the inguinal nodes are often matted; in chancroid the adenopathy is usually a single round extremely tender lesion.

Culture diagnosis is reliable and the "gold standard," but several types of media are required for optimal yield, as well as some unusual conditions (addition of antibiotics, culture temperature less than usual, high humidity, two to five percent CO₂). Despite recurrent descriptions of "simplified," "reliable," easy-to-do culture techniques for *Hemophilus ducreyi*, only large laboratories with experienced personnel are qualified to take on such cultures.

Confusion of Chancroid, Syphilis, and Herpes

Confusion of syphilis and herpes with chancroid, and vice-versa, is an ever present danger. *All* ulcerative genital lesions must include these three in their differential diagnosis. Acute and follow-up syphilis serologies are mandatory, and well as a darkfield exam on three separate days (if available). A Tzanck prep should be considered, as well as a herpes culture if available. In at least some cases, empirical treatment for chancroid, and perhaps syphilis, may be unavoidable. Herpes may sometimes be diagnosed, eventually, by its recurrences.

Sexually Transmitted Diseases

Treatment

Erythromycin 500 mg p.o. q.i.d. for seven days.

Alternative regimens

Ceftriaxone 250 mg IM in single doses

or Trimethoprim/sulfamethoxazole, one double strength tablet (160/800 mg) p.o. b.i.d. for at least seven days.

Erythromycin is the most effective, especially when there is extensive adenopathy. Ceftriaxone has not been evaluated in the U.S., but is probably effective. Trimethoprim/sulfamethoxazole is often effective, but the susceptibility of *Hemophilus ducreyi* varies widely. In a few areas a single dose is sufficient; in other areas it is resistant.

Keeping the ulcers, or suppurative bubos, clean and dry may speed healing. Fluctuant bubos should be aspirated to prevent spontaneous breakdown and discharge through the skin, however a superior approach should be used to prevent iatrogenic sinus formation. Incision and drainage should not be done since it generally produces open wounds that require weeks to months to heal. Although chancroid in the past has caused significant phimosis with difficulty voiding, surgical intervention (dorsal slit of the prepuce) should be avoided if at all possible. The procedure often results in autoinoculation and additional infection, and requires a subsequent circumcision.

Sex partners should be treated with the same regimen, even in the absence of symptoms.

Lymphogranuloma Venereum (LGV)

LGV is caused by *Chlamydia trachomatis*, however the strains involved are L1, 2, 3, as opposed to strains A - K, which cause nongonococcal urethritis and other infections. Initial inoculation is usually in the genital area (coronal sulcus, prepuce, glans in men; fourchette, vagina, cervix in women), but may occur at other sites, including mouth and rectum. Incubation prior to the initial lesion is usually seven to twelve days. The initial lesion is usually a small, painless vesicle or superficial nonindurated ulcer. It is only noticed in 30 percent of heterosexual men, and less often in women, although associated local edema may produce phimosis or swelling of the labia. Rectal inoculation produces bloody anal discharge, diarrhea, and cramps.

Clinical Course

Seven to 30 days (sometimes up to 50 days) after the primary lesion (which usually was not noticed by the patient), regional adenopathy appears. (Note that at the extreme, the characteristic adenitis of LGV, may not, therefore, appear until about 60 days after exposure.) This involves the inguinal nodes, however up to 75 percent of cases may also have deep node involvement. Initial sensations of aching and stiffness in the groin may give way to swelling. Other nodes become involved, and form a matted mass attached to the overlying skin. There may be an overlying reddish-purple discoloration. Often, nodes above and below Poupart's ligament are involved, producing the "groove sign" (i.e., a groove due to the ligament dividing the adenopathy). The adenopathy is unilateral in 65 to 75 percent of patients. It may subside spontaneously, or become fluctuant eventuating into chronic draining sinuses.

In some patients, lymphatic spread may be associated with systemic symptoms (fever, chills, malaise, arthralgia, myalgia), and mild laboratory abnormalities. Urinary retention and cystitis symptoms are common if pelvic nodes are involved. Most cases resolve on their own, even without treatment. But a small percentage, mostly women, develop elephantiasis due to obstructed lymphatic drainage, or rectal strictures.

Diagnosis

The Frei test is obsolete, and not available in the U.S. Even when available there were problems with lack of specificity, cross-reactions, and limited (less than 70 percent) sensitivity. The LGV complement fixation test is 90 to 95 percent sensitive, but is nonspecific. Some additional usefulness can be obtained by titrating the results. In the presence of a compatible clinical syndrome, a titer of equal to or greater than 1:64 is suggestive enough to start treatment. In most cases however, the diagnosis is clinical.

Treatment

Tetracycline 500 mg p.o. q.i.d. for at least 14 days.

Alternative regimens

Doxycycline 100 mg p.o. b.i.d. for at least 14 days,

or Erythromycin 50 mg p.o. q.i.d. for at least 14 days,

or Sulfamethoxazole 1.0 gram p.o. b.i.d. for at least 14 days.

Sexually Transmitted Diseases

The alternative regimens are effective in vitro, but have not been extensively clinically evaluated. Sex partners should be treated with the same regimen, even in the absence of symptoms.

Fluctuant nodes should be aspirated as needed through healthy adjacent normal skin. A superior approach should be used to avoid iatrogenic sinuses. Incision and drainage or excision of nodes will delay healing and are contraindicated.

Ano-Genital Warts (Condylomata Acuminata)

Genital warts is a largely sexually transmitted disease caused by several strains of the human papilloma virus (HPV). It is the fastest increasing STD in the U.S., and has significant long-term implications. Babies who get infected during delivery may develop laryngeal papillomas, a very difficult lesion to treat. HPV strains 6 and 11 are mostly associated with condylomata, but strains 16 and 18 have been associated with precancerous changes, and may be oncogenic viruses. Atypical or persistent warts should be biopsied. A Pap smear is recommended for all women with genital warts. Cervical warts should not be treated until the results of a Pap smear are available to guide therapy.

Both cryotherapy and podophyllin are used to treat genital and rectal warts, but some consultants feel cryotherapy is preferable. Podophyllin should not be used during pregnancy, and is not recommended for cervical warts. It is absorbable and toxic; use of large amounts should be avoided. Treatment of vaginal, cervical, urethral or intrarectal warts should be carried out in consultation with an expert. Interferon shows promising albeit limited results. It is still experimental and its ultimate usefulness remains to be determined.

Pearly Penile Papules

Pearly Penile Papules, sometimes confused with penile warts, are a benign pearly white growth seen around the corona. Lesions range in number from one or two, up to enough to form a solid necklace around the corona. They are homogenous in size (2 to 3 mm), shape (dome shaped), and color. Their cause is not known, but once developed they are permanent. Their importance is largely an educational issue. They are not an STD. The patient neither got them from anyone, nor can he transmit them to anyone. Podophyllin and cryotherapy are not effective. Treatment is neither needed nor available. Reassurance of the patient is appropriate management.

Molluscum Contagiosum

Molluscum contagiosum is a worldwide disease, affecting primarily children and young adults. In the latter, it is often a sexually transmitted disease, and appears in the genital area. It is due to a DNA-containing pox virus.

The incubation period is usually two to seven weeks, with a range of one week to six months. The disease has a low incidence, about one case per 42 to 60 cases of gonorrhea, but is often associated with other STDs. Autoinoculation can occur, and so may produce additional lesions, often in a linear string. Most patients are asymptomatic, but a few have pain, itching, and tenderness.

Diagnosis

Diagnosis is usually clinical. The lesions are one to 15 mm, firm, round, waxy, smooth-surfaced, pearly-to-flesh-colored discrete papules. Usually the apex is umbilicated, a useful diagnostic point. A cheesy, milky-white substance made up of elementary bodies containing the virus and the husks of epidermal cells can be easily expressed from the lesions. This material can be stained by Pap, Wright, Giemsa, or Gram stain, to reveal the characteristic lesions.

Treatment

The lesions usually resolve spontaneously in about two months, without scarring. Treatment, however, can prevent autoinoculation and sexual spread of the disease, and may be requested by the patient for cosmetic reasons.

References and Bibliography

The diagnosis, clinical manifestations, and treatment of sexually transmitted diseases are constantly changing. One of the most useful sources for keeping current in this area is *Morbidity Mortality Weekly Reports*, published by the Centers for Disease Control. It is available at a rather modest cost, including first class delivery and all supplements, through the Massachusetts Medical Society, PO Box 9120, Waltham, MA, 02254-9120. Credit card orders: 1-800-843-6356.

General

Felman, Y.M., (Ed.). *Sexually transmitted diseases*. New York: Churchill, Livingstone, 1986.

Hansfield, H.H. Problems in the treatment of bacterial sexually transmitted diseases. *Sexually Transmitted Diseases*, 1986, 13 (Suppl), 179-184.

Holmes, K.K., Mardh, P.A., Sparling, P.F., & Wiesner, P. J. (Eds.). *Sexually transmitted diseases*. New York: McGraw Hill, 1984.

Naval Medical Command. Sexually transmitted diseases (STD) treatment guidelines (NAVMEDCOMINST 6222.1).

Sexually Transmitted Diseases

- 1985 STD Treatment guidelines. *Morbidity Mortality Weekly Reports*, 18 October 1985, 34, Supplement No. 4S.
- Stone, K.M., Grimes, D.A., & Magder, L.S. Primary prevention of sexually transmitted diseases. *Journal of the American Medical Association*, 1986, 255, 1763-1766.
- Wentworth, B.B., & Judson, F.N. (Eds.). *Laboratory methods for the diagnosis of sexually transmitted diseases*. Washington, DC: American Public Health Association, 1985. Wong, ES., & Stamm, W.E. Urethral infections in men and women. *Annual Review of Medicine*, 1983, 34, 337-358.

Pelvic Inflammatory Disease

- Burakis, T.G., & Hildebrandt, N.B. Pelvic inflammatory disease: A review with an emphasis on antimicrobial therapy. *Review of Infectious Diseases*, 1986, 8, 86-116.
- Brunhan, R.C., Binns, B., Guijon, F., et al. Etiology and outcome of acute pelvic inflammatory disease. *Journal of Infectious Diseases*, 1988, 158, 510-517.
- Brusch, J.L. Pelvic inflammatory disease. *Infectious Disease Practice*, 1988, 11, 1-8.
- Dalabetta, G., & Hook, E.W. Gonococcal infections. *Infectious Disease Clinics of North America*, 1987, 1, 25-54.
- Dodson, M.G., & Faro, S. The polymicrobial etiology of acute pelvic inflammatory disease and treatment regimens. *Review of Infectious Diseases*, 1985, 7, S696-S702.
- Dromer, B.A., & Heald, F.P. Pelvic inflammatory disease associated with *Neisseria gonorrhoeae* and *Chlamydia trachomatis*: Clinical correlates. *Sexually Transmitted Diseases*, 1987, 14, 125-129.
- Duncan, W.C. Gonorrhea 1983. *Dermatologic Clinics*, 1983, 1, 43-52.
- Eschenbach, D.A. Acute pelvic inflammatory disease. *Urologic Clinics of North America*, 1984, 11, 65-82.
- Hook, E.W., & Holmes, K.K. Gonococcal infections. *Annals of Internal Medicine*, 1985, 102, 229-243.
- Hooten, T.M., & Barnes, R.C. Urethritis in men. *Infectious Disease Clinics of North America*, 1987, 1, 165-178.
- Rice, R.J., & Thompson, S.E. Treatment of uncomplicated infections due to *Neisseria gonorrhoeae*. A review of clinical efficacy and in vitro susceptibility studies from 1982 through 1985. *Journal of the American Medical Association*, 1986, 255, 1739-1746.
- Spence, M.R. Pelvic inflammatory disease. *Dermatologic Clinics*, 1983, 1, 65-74.
- Stamm, W.E. Lower genital tract infections in women. *Infectious Disease Clinics of North America*, 1987, 1, 179-198.
- Sweet, F.L. Pelvic inflammatory disease. *Sexually Transmitted Diseases*, 1986, 13, 192-198.
- Sweet, F.L. Pelvic inflammatory disease and infertility in women. *Infectious Disease Clinics of North America*, 1987, 1, 199-216.
- Washington, A.E., Amo, F.S., & Brooks, M.A. The economic cost of pelvic inflammatory disease. *Journal of the American Medical Association*, 1986, 255, 1735-1738.
- Wasserheit, J.N., & Holmes, K.K. Sexually transmitted diseases in women: Approach to common syndromes in emergency medicine. *Emergency Medical Clinics of North America*, 1985, 3, 47-74.
- Watts, D.H., & Eschenbach, D.A. Sexually transmitted diseases in pregnancy. *Infectious Disease Clinics of North America*, 1987, 1, 253-276.
- Quan, M., Johnson, R., & Rodney, W.M. The diagnosis of acute pelvic pain. *Western Journal of Medicine*, 1983, 139, 110-113.

Nongonococcal Urethritis (NGU), *Chlamydia Trachomatis*

- Batteiger, B.E., & Jones, R.B. Chlamydia infections. *Infectious Disease Clinics of North America*, 1987, 1, 55-82.
- Bowie, W.R. Nongonococcal urethritis. *Dermatologic Clinics* 1983, 1, 53-64.
- Brunham, R.C. Mucopurulent cervicitis - the ignored counterpart in women of urethritis in men. *New England Journal of Medicine*, 1984, 311, 1-6.
- Chlamydia trachomatis* infections: Policy guidelines for prevention and control. *Morbidity, Mortality Weekly Report*, 23 August 1985, 34, Supplement No. 3S.
- Hansfield, H.H. Control of sexually transmitted chlamydial infections. *Journal of the American Medical Association*, 1987, 257, 2073-2074.
- Jones, R.B. *Chlamydia trachomatis* in the pharynx and rectum of heterosexual patients at risk for genital infection. *Annals of Internal Medicine*, 1985, 102, 757-762.
- Sander, L.L., Harrison, H.R., & Washington, A.E. Treatment of sexually transmitted chlamydial infections. *Journal of the American Medical Association*, 1986, 255, 1750-1756.
- Stamm, W.E. Diagnosis of *Chlamydia trachomatis* genitourinary infections. *Annals of Internal Medicine*, 1988, 108, 710-717.
- Stamm, W.E. Effect of treatment regimens for *Neisseria gonorrhoeae* on simultaneous infection with *Chlamydia trachomatis*. *New England Journal of Medicine*, 1984, 310, 545-549.
- Stamm, W.E., Koutsky, L.A., Benedetti, J.K., Jourden, J.L., Brunham, R.C., & Holmes, K.K. *Chlamydia trachomatis* urethral infections in men: Prevalence, risk factors, and clinical manifestations. *Annals of Internal Medicine*, 1984, 100, 47-51.
- Stimson, J.B., Hale, J., Bowie, W.R., & Homes, K.K. Tetracycline-resistant *Ureaplasma urealyticum*: A cause of persistent nongonococcal urethritis. *Annals of Internal Medicine*, 1981, 94, 192-194.
- Wong, E.S., Hooten, T.M., Hill, C.C., McKeivitt, M., & Stamm, W.E. Clinical and microbiological features of persistent of recurrent nongonococcal urethritis in men. *Journal of Infectious Disease's*, 1988, 158, 1098-1101,

Herpes Simplex Virus

- Becker, T.M., & Nahmias, A.J. Genital herpes - yesterday, today, and tomorrow. *Annual Review of Medicine*, 1985, 36, 185-193.
- Chang, T.W. Herpes simplex virus. *Clinics in Dermatology*, April - June, 1984, 2, entire issue.
- Corey, L. The diagnosis and treatment of genital herpes. *Journal of the American Medical Association*, 1982, 248, 1041-1049.
- Corey, L., & Spear, R.G. infections with herpes simplex viruses. *New England Journal of Medicine*, 1986, 314, 686-691, 749-757.
- Dorsky, D.I., & Crunpaker, C.S. Drugs five years later: Acyclovir. *Annals of Internal Medicine*, 1987, 107, 859-874.
- Erlich, K.S., & Mills, J. Chemotherapy for herpes simplex virus infections. *Western Journal of Medicine*, 1985, 143, 648-655.
- Guinan, M.E. Therapy for symptomatic genital herpes simplex virus infection: A review. *Review of Infectious Disease's*, 1982, 4, S819-S828:
- Guinan, M.E. Oral acyclovir for treatment and suppression of genital herpes simplex virus infection: A review. *Journal of the American Medical Association*, 1986, 255, 1747-1749.

Sexually Transmitted Diseases

- Jarratt, M. Genital herpes simplex infection. *Dermatologic Clinics*, 1983, 1, 85-92.
- Kraus, S.J. Evaluation and management of acute genital ulcers in sexually active patients. *Urologic Clinics of North America*, 1984, 11, 155-162.
- Mertz, G.J. Diagnosis and treatment of genital herpes infections. *Infectious Disease Clinics of North America*, 1987, 2, 341-366.
- Pazin, G.J., & Hager, J.H. Management of oral and genital herpes simplex virus infections: Diagnosis and treatment. *Disease-a-Month*, 1986, 32, 727-805.
- Strauss, S.E. Herpes simplex virus infection: Biology, treatment, and prevention. *Annals of Internal Medicine*, 1985, 103, 404-419.
- Webb, D.J., & Fife, K.H. Genital herpes simplex virus infections. *Infectious Disease Clinics of North America*, 1987, 1, 97-122.

Syphilis

- Brown, S.T. Serological response to syphilis treatment: A new analysis of old data. *Journal of the American Medical Association*, 1985, 253, 1296-1299.
- Crissey, J.T. & Deneholz, D.A. (Eds.). Syphilis. *Clinics in Dermatology*, January - March, 1984, 2, Entire issue.
- Drusin, L.M. Syphilis: clinical manifestations, diagnosis, and treatment. *Urologic Clinics of North America*, 1984, 11, 121-130.
- Fitzgerald, F. The great imitator, syphilis. *Western Journal of Medicine*, 1981, 134, 424-432.
- Fiumara, N.J. Infectious syphilis. *Dermatologic Clinics*, 1983, 1, 3-22.
- Hart, G. Syphilis tests in diagnostic and therapeutic decision making. *Annals of Internal Medicine*, 1986, 104, 368-376.
- Hook, E.W., Roddy, R.E., & Handsfield, H.H. Ceftriaxone therapy for incubating and early syphilis. *Journal of Infectious Diseases*, 1988, 158-884.
- Jordan, K.G. Modern neurosyphilis - A critical analysis. *Western Journal of Medicine*, 1988, 149, 80-81.
- Kampmeir, F.H. Late and congenital syphilis, *Dermatologic Clinics*, 1983, 1, 23-42.
- Lukehart, S.A., Hook, E. W., Baker, Zander, S.A., Collier, A.C., Critchlow, C.W., & Handsfield, H.H. invasion of the central nervous system by *Treponema pallidum*: Implications for diagnosis and treatment. *Annals of Internal Medicine*, 1988, 109, 855-862.
- McPhee, S.J. Secondary syphilis: Uncommon manifestations of a common disease. *Western Journal of Medicine*, 1984, 140, 35-42.
- Musher, D.M. How much penicillin cures early syphilis? *Annals of Internal Medicine*, 1988, 109, 849-851.
- Musher, D.M. Syphilis. *Infectious Disease Clinics of North America*. 1987, 1, 83-96.
- Pickering, L.L. Diagnosis and treatment of patients with congenital and primary syphilis. *Pediatric Infectious Disease*, 1985, 4, 602-605.

Chancroid

- Brusch, J.L. Chancroid. *Infectious Disease Practice*, 1986, 10, (9). 1-7.
- Hammond, G.W., Slutchuk, M., Scatliff, J., et al. Epidemiologic, clinical, laboratory, and therapeutic features of an urban outbreak of chancroid in North America. *Review of Infectious Diseases*, 1980, 2, 867-879.

- Hart, G. Chancroid, donovanosis, and lymphogranuloma venereum. *Dermatologic Clinics*, 1983, 1, 75-83.
- Kraus, S.J. Chancroid therapy: A review of cases confirmed by cultures. *Review of Infectious Diseases*, 1982, 4, S848-S856.
- Ronald, A.R., & Plummer, F.A. Chancroid and *Haemophilus ducreyi* (Editorial). *Annals of Internal Medicine*, 1985, 202, 705-707.
- Schmid, G.P. The treatment of chancroid. *Journal of the American Medical Association*. 1986, 255, 1757-1762.
- Schmid, G.R., Sanders, L.L., Blount, J.H., & Alexander, E.R. Chancroid in the United States: Reestablishment of an old disease. *Journal of the American Medical Association*, 1987, 258, 3265-3268.

Genital Warts Molluscum Contagiosum

- Fehnan, Y.M., & Nikitas, J.A. Sexually transmitted molluscum contagiosum. *Dermatologic Clinics*, 1983, 1, 103-111.
- Ferenczy, A., Mitao, M., Nagai, N., et al. Latent papillomavirus and recurring genital warts. *New England Journal of Medicine*, 1985, 313, 784-788.
- Howley, F.M. On human papilloma viruses. *New England Journal of Medicine*, 1986, 315, 1089-1090.
- Kirby, P., & Corey, L. Genital human papillomavirus infection. *Infectious Disease Clinics of North America*, 1987, 1, 123-144.
- Kirby, P. Interferon and genital warts: Much potential, modest progress. *Journal of the American Medical Association*, 1988, 259, 570-572.
- Koutsky, L.S., Galloway, D.A., & Holmes, K.K. Epidemiology of genital human papillomavirus infection. *Epidemiological Reviews*, 1988, 10, 122-163.
- Margolis, S. Genital Warts and molluscum contagiosum. *Urologic Clinics of North America*, 1984, 11, 163-170.
- Orrel, J.D. Condylomata acuminata as a sexually transmitted disease. *Dermatologic Clinics*, 1983, 1, 93-102.
- Rando, R.F. Human papillomavirus: Implications for clinical medicine. *Annals of Internal Medicine*, 1988, 108, 628-630.

STD in Homosexuals

- Ernst, R.S., & Houts, P.S. Characteristics of gay persons with sexually transmitted disease. *Sexually Transmitted Diseases*, 1985, 12, 59-63.
- Mintz, L., & Drew, W.L. Sexually transmitted viral infections in homosexual men. *Medical Clinics of North America*, 1983, 67, 1093-1104.
- Gwen, W.F. Sexually transmitted diseases in the homosexual community. *Dermatologic Clinics*, 1983, 1, 123-130.
- Rompalo, A.M., & Stamm, W.E. Anorectal and enteric infections in homosexual men. *Western Journal of Medicine*, 1985, 142, 647-652.
- Rompalo, A.M., & Quinn, T.C. Sexually transmitted enteric and rectal infections in homosexual men. *Infectious Disease Clinics of North America*, 1987, 1, 235-277.

Miscellaneous

- Beck-Sague, C., Alexander, E.R. Sexually transmitted diseases in children and adolescents. *Infectious Disease Clinics of North American*, 1987, 1, 277-305.

Sexually Transmitted Diseases

- Cunha, B.A. Lymphogranuloma venereum. *Infectious Disease Practice*, 1988, 11, (11). 1-8.
- Drotman, D.P. Epidemiology and treatment of epididymitis. *Reviews of Infectious Diseases*, 1982, 4 (Suppl), S788-S792.
- Iretton, F.C., & Berger, R.E. Prostatitis and epididymitis. *Urologic Clinics of North America*, 1984, 11, 83-94.
- Kraus, S. J. Evaluation and management of acute genital ulcers in sexually active patients. *Urologic Clinics of North America*, 1984, 11, 155-162.
- Krieger, J.M. Epididymitis, orchitis, and related conditions. *Sexually Transmitted Diseases*, 1984, 11, 173-181.
- Krieger, J.N. Biology of sexually transmitted diseases. *Urologic Clinics of North America*, 1984, 11, 15-25.
- Krockta, W.P., & Barnes, R.C. Genital ulceration with regional adenopathy. *Infectious Disease Clinics of North America*, 1987, 1, 217-235.
- Lewis, F.L., & Palmer, J.M. Office diagnosis of epididymitis, epididymoorchitis, and orchitis. *Western Journal of Medicine*, 1980, 133, 270-273.
- Orkin, M. & Maiback, J.I. Scabies and pediculosis pubis. *Dermatologic Clinics*, 1983, 1, 111-122.

APPENDIX A

TREATMENT REGIMENS:

GONORRHEA

NONGONOCOCCAL URETHRITIS (NGU), MUCOPURULENT CERVICITIS

AND SYPHILIS

Gonorrhea

Note

The following regimens are taken from the Centers for Disease Control 1985 recommendations, and generally apply throughout the United States. Consult the "Note" at the end of this section for treatment of gonorrhea in the Western Pacific and California.

Uncomplicated Gonococcal Urethritis and Endocervicitis

Three Options.

1. Amoxicillin 3 gram or ampicillin 3.5 gram p.o. once, plus probenecid 1 gram p.o.
- or* 2. Aqueous procaine penicillin G (APPG) 4.8 million units IM, plus probenecid 1 gram p.o.
- or* 3. Ceftriaxone 250 mg IM once (Probenecid is not needed.)

In Addition To Any Of The Above.

- Tetracycline 500 mg p.o. q.i.d. for seven days.
- or* Doxycycline 100 mg p.o. b.i.d. for seven days.

The addition of a second antibiotic (e.g., a tetracycline) is to cover the chlamydial infection which accompanies up to 45 percent of gonococcal infections, and, untreated, may cause

Sexually Transmitted Diseases

postgonococcal urethritis, cervicitis, or PID. For patients in whom tetracyclines are contraindicated or not tolerated, erythromycin base or stearate, 50 mg p.o. q.i.d. for 7 days, *or* erythromycin ethylsuccinate 800 mg p.o. q.i.d. for 7 days, may be substituted.

Pelvic Inflammatory Disease (PID)

Three Options.

1. Doxycycline 100 mg IV Q12H *plus* cefoxitin 2 gram IV Q6H.

Continue IV antibiotics for at least four days and at least 48 hours after patient improves. Then continue doxycycline 100 mg p.o. b.i.d. to complete 10 to 14 days total therapy.

- or* 2. Clindamycin 600 mg IV Q6H *plus* gentamicin 2.0 mg/kg IV, followed by 1.5 mg/kg Q8H in patients with normal renal function. (Appropriate toxicity monitoring is indicated.)

Continue IV antibiotics for at least four days and at least 48 hours after patient improves. Then continue clindamycin 450 mg p.o. q.i.d. to complete 10 to 14 days total therapy.

- or* 3. Ambulatory PID Treatment Regimen.

Any of the single dose treatment regimens used for uncomplicated gonorrhea, *or* cefoxitin 2 gram IM (plus) probenecid 1 gram p.o.

Any One of These is Followed By.

Doxycycline 100 mg p.o. b.i.d. for 10-14 days.

Disseminated Gonococcal Infection (DGI)

Three Options.

1. Aqueous crystalline penicillin G, 10 million units IV per day for at least three days, followed by amoxicillin or ampicillin, 500 mg p.o. q.i.d. to complete seven days therapy.

or 2. Amoxicillin 3 gram p.o. or ampicillin 3.5 gram p.o. each with probenecid 1 gram p.o., *followed by* either amoxicillin *or* ampicillin 500 mg p.o. q.i.d. for at least seven days.

or 3. Cefoxitin 1 gram IV Q6H or cefotaxime 500 mg IV Q6H *or* ceftriaxone 1 gram IV once daily; each for at least seven days.

Patients treated with any of the above regimens should receive an additional seven days of tetracycline, doxycycline, or erythromycin, as outlined above, for possible coexisting chlamydial infection.

Microbial confirmation of *disseminated* infection is not always possible, but a reasonably dramatic symptomatic response after 48 to 72 hours of appropriate treatment can be considered a presumptive identification. (However, occasional cases of DGI due to penicillin-resistant gonorrhea have been reported.) A compatible clinical presentation plus recent or current positive cultures from urethra, cervix, rectum, or pharynx, or a compatible clinical picture in a patient whose sex partner has recently had gonorrhea, may also be considered presumptively diagnostic. Despite negative pretreatment cultures, test-of-cure cultures (same four sites) are required four to seven days after completing treatment.

Pharyngeal Gonorrhea

Treatment is with any of the regimens for uncomplicated gonococcal urethritis, *except spectinomycin*. Ceftriaxone (250 mg IM) is effective against pharyngeal gonorrhea due to PPNG, as is Septra or Bactrim (nine single strength (80 mg trimethoprim/400 mg sulfamethoxazole) tabs, taken all at once, once daily for five days). *Two* test-of-cure cultures are required, at least four days apart. Asymptomatic patients whose pharyngeal cultures are positive for gonorrhea should be treated.

Rectal Gonorrhea

Treatment is the same as for uncomplicated gonococcal urethritis, however, the cure rate is slightly less, especially in men. Test-of-cure cultures are mandatory, four to seven days after treatment.

Note: Western Pacific, California Gonorrhea

As of 1988, the Republic of the Philippines (Subic Bay) joins Korea in having a high prevalence, about 10 to 13 percent, spectinomycin-resistant gonorrhea. These strains may also be

Sexually Transmitted Diseases

resistant to penicillin, or they may be sensitive to it. For this reason, the drug of choice for all gonorrhea acquired in the Western Pacific (WESPAC) is ceftriaxone, with the dose determined by the particular manifestation of the infection. For urethritis, endocervicitis, proctitis, or pharyngitis, this is a single IM dose of 250 mg. For pelvic inflammatory disease (PID) or disseminated gonococcal infection (DGI), higher and more prolonged doses are required.

A significant prevalence of *penicillinase-producing Neisseria gonorrhoeae* (PPNG) has been noted in California (San Diego County, Naval Hospital Oakland). For these reasons, and to reduce complications arising from numerous treatment regimens, all gonorrhea in California, and perhaps the entire West Coast, should also be treated with ceftriaxone as the drug of choice. However, it is important for medical officers to appreciate the dual rationale behind this decision, and to realize that spectinomycin resistance is not a problem on the West Coast (although a returnee from Southeast Asia might present with such a strain). Therefore West Coast-acquired gonorrhea, at least for the immediate future, will be sensitive to both ceftriaxone and spectinomycin.

Although the recommendation to use ceftriaxone as the drug of choice in WESPAC is quite appropriate, stocks of spectinomycin do not necessarily have to be discarded. They can be used, if necessary, however a 10 to 15 percent failure rate must be anticipated and diligently watched for. Also, cefoxitin (2 gram IM plus 1000 mg probenecid po) will probably continue to be an effective alternative, at least for the immediate future. This is not the drug of choice, but may be more readily available in WESPAC than ceftriaxone.

In general, gonococcal isolates from third world countries exhibit a significant degree of antibiotic resistance, and management of this situation changes rapidly. Whenever possible, the appropriate Environmental and Preventive Medicine Unit should be consulted for the latest information. If this is not readily available however, the use of ceftriaxone is appropriate.

Nongonococcal Urethritis (NGU) and Mucopurulent Endocervicitis

Basic Treatment

Basic treatment, and the most effective, uses a *tetracycline*.

Two Options.

1. Tetracycline: 500 mg p.o. q.i.d. for seven days.

or 2. Doxycycline 100 mg p.o. b.i.d. for seven days.

Longer periods, (10, 14, 21 days), have been proposed, but these do not produce better results except possibly in patients who miss doses or when adequate overlap of the sex partner's treatment is a concern. Doxycycline is no better than tetracycline, except in those patients who clearly cannot tolerate tetracycline.

Erythromycin

Erythromycin is an alternative regimen for patients in whom tetracyclines are contraindicated or not tolerated.

Two Options.

1. Erythromycin base or stearate: 500 mg p.o. q.i.d. for seven days.

or 2. Erythromycin ethyl succinate: 800 mg p.o. q.i.d. for seven days.

Sulfonamides

Sulfonamides (e.g., sulfamethoxazole 1 gram p.o. b.i.d. for 10 days) are active against chlamydia, but may not be active against ureaplasma or other organisms which may cause NGU. For this reason they are not suitable for treatment of NGU when chlamydia is not definitively diagnosed. They may be acceptable in patients who cannot tolerate either tetracyclines or erythromycin, but a higher failure rate should be anticipated.

Note. Tetracyclines bind to some foods, especially high calcium foods such as dairy products (milk, cheese, ice cream, yogurt), as well as antacids (e.g., Maalox, Mylanta), iron preparations, and Pepto Bismol. Under these circumstances, absorption of tetracycline may be greatly reduced. Therefore tetracycline should be taken on an empty stomach, no food for two hours before and one hour after each dose. Doxycycline is not bound by foods, including dairy products, and can therefore be taken with meals. It is, however, bound by antacids, iron preparations, and Pepto Bismol.

Syphilis

Early Syphilis

Primary, secondary, latent syphilis of less than one year:

Sexually Transmitted Diseases

1. Benzathine penicillin G 2.4 million units total IM at a single session.

Patients who are allergic to penicillin:

2. Tetracycline 500 mg p.o. q.i.d. for 15 days.

Penicillin allergic patients who cannot take tetracycline.

3. Erythromycin 500 mg p.o. q.i.d. for 15 days.

Note. Tetracycline, and especially erythromycin, have not been extensively tested in a clinical setting. If either of these is used, close and prolonged serological and clinical follow-up is mandatory.

Syphilis Of More Than One Year's Duration

Latent syphilis of indeterminate or more than one year's duration; cardiovascular or late benign (tertiary):

1. Benzathine penicillin G 2.4 million units IM once a week for three successive weeks (7.2 million units total).

Patients who are allergic to penicillin:

2. Tetracycline 500 mg p.o. q.i.d. for 30 days.

Penicillin allergic patients who cannot take tetracycline:

3. Erythromycin 500 mg p.o. q.i.d. for 30 days.

Note. See Note above under "Early Syphilis."

Neurosyphilis

1. Aqueous crystalline penicillin G 12 to 24 million units IV per day (two to four million units every four hours) for 10 days, *followed by*, benzathine penicillin G 2.4 million units IM weekly for three doses.

U.S. Naval Flight Surgeon's Manual

or 2. Aqueous procaine penicillin G 2.4 million units IM daily, *plus* probenecid 500 mg p.o. q.i.d., *both* for 10 days; *followed by* benzathine penicillin G 2.4 million units IM weekly for three doses.

or 3. Benzathine penicillin G 2.4 million units IM weekly for three doses.

Note. The choice of treatment for neurosyphilis is somewhat controversial, however most infectious disease specialists would use regimen "1", or if that were not possible, regimen "2."

APPENDIX B

LABORATORY TESTS FOR GONOCOCCAL INFECTIONS

Cultures Are Mandatory For

1. Equivocal Gram stains or nonexudative urethritis.
2. Endocervicitis.
3. To diagnose any type of antibiotic resistance.
4. To rule out asymptomatic gonorrhea.
5. For test-of-cure purposes.

Urethritis

1. A properly done Gram stain is about 85 percent diagnostic in males. An equivocal Gram stain is culture positive 25 to 50 percent of the time. Ideally, four hours should have elapsed since last urination. If Gram stain is equivocal, and patient has urinated more recently than four hours, having him return in two to three hours without urinating may yield better information.
2. Insert a sterile calcium alginate swab about 2 cm into the urethra, which is on the ventral side of the penis, not in the center. Leave swab in 10 to 30 seconds for absorption. Remove with a twisting motion.
3. Roll swab on a glass slide, then streak onto a Thayer-Martin agar plate. Plate should be at room temperature (i.e., not just out of the refrigerator). Streak only one edge, not the entire plate.
4. Incubate promptly in candle jar or CO₂ incubator at 35°C.
5. Chocolate agar plates increase the yield slightly, but are seldom needed. If used, streak chocolate first, then onto a Thayer-Martin plate.

Endocervicitis

1. Gram stains are of limited use since sensitivity is only 50 to 65 percent. Sometimes Gram stains may show false positives.
2. Moisten speculum with warm water only. Lubricants contain antibacterial preservatives which may interfere with culture.
3. Remove excess cervical mucous with cotton swabs. Insert a sterile cotton-tipped swab one to two cm into the cervix. (A calcium alginate swab is not needed).
4. Move swab from side to side for 10 to 30 seconds, allowing time for absorption of bacteria.
5. Streak onto Thayer-Martin. (Chocolate will be overgrown.)
6. A rectal culture adds 1 to 2 percent additional cases. It is not cost effective in routine screens (e.g., with a Pap smear) but should be obtained any time gonorrhea is suspected.

Pharyngitis

1. A Gram stain is not useful, due to normal, nonpathogenic oral *Neisseria* species.
2. Obtain cultures only in special cases.
3. Vigorously swab tonsils and pharynx, and streak on Thayer-Martin media.
4. Culturette swabs, such as used for strep throat, will not work.
5. *Prominently* mark chit: "Gonorrhea culture."

Proctitis

1. Gram stain is of limited use, since it is only about 30 percent sensitive.
2. Insert a sterile cotton-tipped swab about 2 cm into the rectum, just proximal to the sphincter.
3. Leave in 10 to 30 seconds.

Sexually Transmitted Diseases

4. Discard swab if there is much fecal staining.
5. Streak onto Thayer-Martin.
6. Prominently label chit: "Gonorrhea culture."

Asymptomatic Sexual Contacts and "Conscience Checks"

1. Men require a urethral culture; women an endocervical and rectal culture; homosexual men a urethral, rectal, and pharyngeal culture.
2. Ask about oral or rectal sex. If these areas were involved, they should be cultured.

APPENDIX C

EVALUATION OF GENITAL ULCERS

Feature	Syphilis	Chancroid	Herpes	LGV	Granuloma Inguinale
Initial Lesion	Papule	Pustule or papule	VESICLE	Pustule or papule	Papule
Border	Rolled, elevated	UNDERMINED	Erythematous		ROLLED, ELEVATED
Number of Lesions	One or multiple	One to three	MULTIPLE	ONE	One or multiple
Depth of Lesion	Shallow	EXCAVATED DEEP	Superficial	Superficial	Elevated above skin
Induration	FIRM, HARD	May be indurated; usually soft	None	None	FIRM, HARD
Pain Base	RARE	OFTEN Yellow, gray purulent	Common Erythematous	Variable	RARE Red, rough, granular
Drainage	Serous	Bloody or purulent	Serous		Bloody

Notes

1. Findings which are CAPITALIZED are useful diagnostically. Others are "characteristic," but not particularly diagnostic. However the "gold standards" remain culture, darkfield, and biopsy.

Sexually Transmitted Diseases

2. Multiple small grouped vesicles, which often coalesce into a large ulcer, are characteristic of primary herpes. Recurrent disease may have many, or only one or two, lesions.
3. The initial penile lesion of LGV is usually small, transient, and not noticed by the patient.
4. GI is characterized by a chronic (weeks to months) spreading lesion, which often leaves a trail of healed/scarred tissue in its wake.
5. “Induration” and “pain” should be tested by squeezing the lesion. GI and syphilis lesions are occasionally painful if secondarily infected.
6. Adenopathy associated with chancroid, LGV, and herpes is usually painful. Adenopathy associated with syphilis is rarely painful.

CHAPTER 12

AEROSPACE PSYCHOLOGICAL QUALIFICATIONS

- Introduction
- History and Development
- Description
- Score Interpretation
- Qualification Standards
- Effectiveness of the Aviation Selection Test Battery
- Bibliography

Introduction

The purpose of this section is to familiarize the reader with the U.S. Navy and Marine Corps Aviation Selection Test battery (ASTB), its utilization within the aviation officer selection program, and its effectiveness as a selection device. To accomplish these objectives, the development of the current test battery is briefly summarized, followed by discussions of the current usage of the test. Evidence of test effectiveness is offered to illustrate the importance of the ASTB in aviation officer selection.

The U.S. Navy and Marine Corps Aviation Selection Test battery is a paper-and-pencil type test used as the primary instrument for selecting student naval aviators (pilots), student naval flight officers (NFOs), and officer candidates for Officer Candidate School (OCS). The test battery was developed specifically for naval aviation to provide: (1) a selection tool that is economical in both time and money, (2) an accurate probability statement of an applicant's potential for completing aviation training, and (3) a standardized, fair evaluation of thousands of applicants annually from throughout the United States and the naval services.

History and Development

Psychological Assessment in Aviation Selection

In the early 1900's the selection of flight candidates was based primarily on physical qualifications. The high attrition rates of flight candidates and the high incidence of World War I pilot

U.S. Naval Flight Surgeon's Manual

casualties due to human error emphasized screening inadequacies and the need for psychological assessment. In 1939 the National Research Council, upon the request of the Civil Aeronautics Authority, undertook a program to select candidates for a nationwide light plane training program. Favorable acceptance of this initial development of aviation selection tests led to the creation of the Medical Research Section of the Bureau of Aeronautics. The responsibility for directing the development and validation of psychological tests for use in pilot selection was later transferred to the Aviation Psychology Section of the Bureau of Medicine and Surgery.

With World War II came increasing demands for aviators and improved selection procedures. The Pensacola 1000 Aviator Study evaluated the predictive validity of the three selection tests then in use: the Wonderlic Personnel Test, the Bennet Mechanical Comprehension Test, and the Purdue Biographical Inventory, plus approximately 10 other psychological, psychomotor, and physical tests. The results verified the effectiveness of the three instruments and indicated the usefulness of psychomotor devices in prediction. However, these devices were never implemented because they could not be administered easily and inexpensively at decentralized test stations and they tended to be unreliable measures.

In 1942 a single index, the Flight Aptitude Rating (FAR), was introduced. The FAR was a result of the application of multiple regression techniques to selection research, and reflected the combination of a Mechanical Comprehension Test (MCT), and a Biographical Inventory (BI). The following year the Wonderlic Personnel Test was replaced with the aviation Classification Test, a test of general intelligence which included judgment, arithmetic, vocabulary, meter reading, and checking.

Studies continued to refine tests in the aviation selection test battery and to permit development of new tests. Since results showed that spatial orientation was significant in the prediction of success in flight training, the Spatial Apperception Test (SAT) was included in the revised test battery implemented in 1953. This version consisted of the Aviation Qualification Test, SAT, MCT, and BI.

The current U.S. Navy and Marine Corps Aviation Selection Test battery was developed by the Bureau of Medicine and Surgery (BUMED) in conjunction with the Naval Aerospace Medical Research Laboratory (NAMRL) at Pensacola, Florida, and with contract efforts funded jointly by BUMED and the Bureau of Naval Personnel (BUPERS). The total development involved extensive field studies of many tests and empirical validation procedures. The revision was implemented in 1971, and in 1972 the Officer Aptitude Rating (OAR) was introduced to be utilized in the selection of nonaviation personnel.

Aerospace Psychological Qualifications

A 1979 Department of Defense review of aviation selection test research, development, validation, interpretation, and use determined that the test was consistent with federal guidelines on employee selection.

The management and operation of the aviation selection test program was assigned to the Naval Aerospace Medical Institute (NAMI) in 1981. Monitoring of the tests is carried on continuously at NAMI to ensure that the tests maintain predictive validity. Although the validity of the current tests continues to be demonstrable, they have lost some of their ability to make precise probability statements of success in training. To increase test effectiveness, revision of the current test battery was begun in 1984 with a contract award to Educational Testing Service.

Data Banks

Maintenance of the selection testing program requires the monitoring of test validity and the conduct of studies to respond to recruiting, training, and operational issues related to the prediction and assessment of performance in aviation missions. Three data banks: the Selection Test Data Bank, the Flight Student Data Bank, and the Human Factors Data Bank provide the necessary data. The Selection Test Data Bank contains all applicant test data since 1968. Data on approximately 30,000 applicants are added to the data bank annually. The Flight Student Data Bank contains undergraduate flight training data for all students who have entered naval aviation training since 1968. The Human Factors Data Bank contains test item response data used in generating a pool of test items for future test revisions.

Research and Development

Because of the practicality, standardization, and the low cost of paper-and-pencil screening, this approach continues as the primary selection tool. Current selection research for alternate approaches includes: the evaluation of flight simulators; job samples; the evaluation of vestibular disorientation tests, integrated multitask performance and cognitive tests, psychomotor tests, and tests of selective attention ability as predictors of flight performance; and the evaluation of the role of computer interactive testing.

Description

The aviation selection test battery consists of four paper-and-pencil tests: the Academic Qualification Test (AQT), the Mechanical Comprehension Test (MCT), the Spatial Apperception Test (SAT), and the Biographical Inventory (BI). There are two equivalent forms of each of the tests. Descriptive information regarding the tests is provided in Table 1.

U.S. Naval Flight Surgeon's Manual

Table 12-1

U.S. Navy and Marine Corps Aviation Selection Tests

Title	Item Content	Attributes
Academic Qualification Test (AQT) 105 Items, 60 Minutes	Quantitative Ability Verbal Ability Practical Judgement Clerical Speed and Accuracy Following Directions	General Intelligence
Flight Aptitude Rating (FAR)		
Mechanical Comprehension Test (MCT) 75 Items, 40 Minutes	Mechanical Aptitude	Ability to perceive physical relationships and solve practical problems in mechanics
Spatial Apperception Test (SAT) 34 Items, 10 Minutes	Spatial Orientation	Ability to perceive spatial relationships from differing orientations
Biographical Inventory (BI) 160 Items, Untimed	Personal History Interests Attitudes Aviation Information	Maturity, risk-taking behavior, and informal acquisition of aerospace knowledge

Under current usage, aviation officer selection is based upon two scores: The AQT score and the Flight Aptitude Rating (FAR) score. The AQT is a general aptitude test and is predictive of ground school performance. The FAR represents a combination of scores on the MCT, SAT, and

Aerospace Psychological Qualifications

BI. These tests measure familiarity with mechanical concepts, ability to visualize the relationship between the attitude of a plane and the territory over which it flies, personal history, and aviation knowledge. The FAR is predictive of success or failure in the flight training program.

Scores from the AQT and MCT are combined to form the Officer Aptitude Rating which is used in selection for nonaviation officer programs. The Commander, Navy Recruiting Command, and the Commandant of the Marine Corps determine which nonaviation programs use these tests and issue appropriate directives regarding their usage.

Score Interpretation

The tests are manually scored at the recruiting station and forwarded to the Aerospace Psychological Qualifications Department (Code 41), Naval Aerospace Medical Institute, for machine scoring and verification.

Performance on the AQT and FAR is scaled in stanines, the contraction for "standard nines." The stanine scale is a condensed form of the T-scale. Stanine scores span two standard deviations on either side of the mean in a standard normal distribution. The scores range from 1 to 9 and have a mean of 5.

Performance on the OAR is scaled in T-scores. T-scores span five standard deviations on either side of the mean in a standard normal distribution. The scores range from 0 to 100 and have a mean of 50. A centile rank gives the percentage of scores in the whole distribution that fall below a given score. Figure 1 shows the relationships among the T-scale, the standard normal distribution, the stanine scale, and centile ranks.

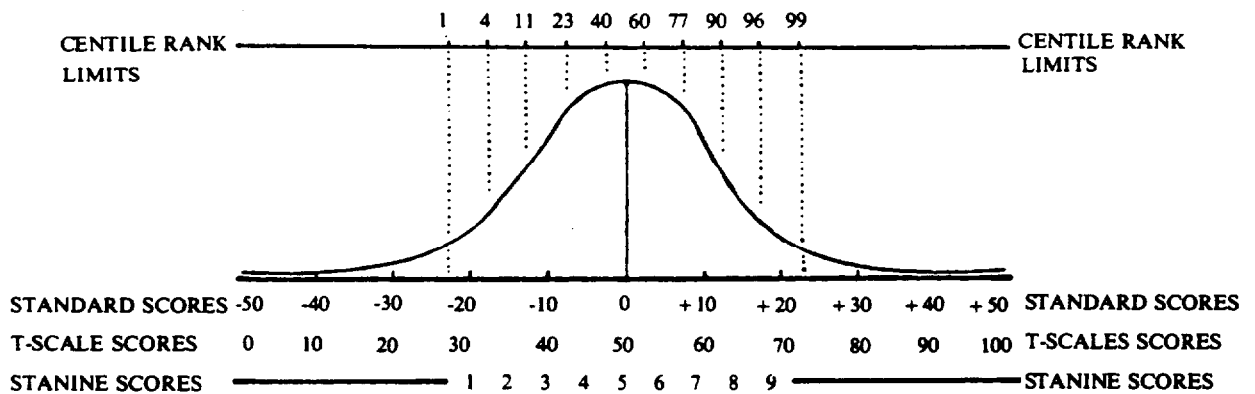

Figure 12-1. Centile rank limits, T, and stanine score scales and their relationship to the standard-score scale extending over a range of 10 sigma units.

Qualifications Standards

The Naval Medical Command sets the minimum acceptable scores on the aviation selection tests. Selection standards may be adjusted in response to changes in manpower requirements as well as in availability and quality of applicants. Accordingly, the Navy Military Personnel Command (NMPC); Headquarters, U.S. Marine Corps; and Headquarters, U.S. Coast Guard may set higher minimum score requirements.

Naval Medical Command absolute minimum scores for pilot selection are 3/3 (AQT/FAR) and are 3/1 for NFO selection. The Navy Recruiting Command currently uses 3/5 for pilots and 3/3 for NFO's. The Marine Corps uses 4/6 for pilots and NFO's.

Effectiveness of the Aviation Selection Test Battery

Role of Selection Tests

In a recent year, well over 100,000 individual prospects were contacted by recruiters from the naval services in order to fill the 2000 seats in aviation ground school classes at the Naval Aviation Schools Command (NASC). Even with such a high degree of prescreening, about one-third of those who enter undergraduate pilot training do not earn their wings. Aviation selection tests play an important, early role in the screening of aviation officer applicants; the objective of testing is to select those applicants most likely to succeed in training.

Table 12-2 shows how, for each 1000 fleet qualified naval aviators, almost 10,000 administrations of the aviation selection tests are required. Half of the applicants fail to attain the minimum qualifying scores, currently 3 on AQT and 5 on the FAR for civilian applicants.

Correlations with Aviation Training Grades

Correlation coefficients indicate the degree of relationship between two variables. Higher correlations signify that variations in one variable are more closely associated with variations in the other variable. Table 12-3 presents the correlation coefficients between each of the subtests of the aviation selection test and three aviation training grades. Correlations of about .30 are moderately strong and indicate an association between certain pairs of variables. The most notable of these associations are the correlation between the AQT and NASC final grade and the correlation between the FAR and primary flight grade. The values of these correlations, together with the remainder of the pattern of correlations, help to demonstrate that the selection tests are predictive of the intended criteria: academic success and success in flight training.

Aerospace Psychological Qualifications

Table 12-2

The Making of a Naval Aviator, 1984

Recruiting and Selection	
81,248 - Contacted	
9,636 - Take Aviation Selection Tests	4,818 Fail: 771 -AQT 4,047 - FAR
4,818 - Take Physical Examination	1,403 Fail Initial Physical
3,415 - Qualify for Further Processing	683 Withdraw
2,732 - Submit Applications to NMPC	576 Fail NMPC Review 436 Fail NAVMEDCOM Review
1,720 - Quality for Aviation Officer Training	295 Decline Appointment
Training	
1,425 - Enter Undergraduate Pilot Training	375 Attrite
1,050 - Enter Readiness Training	50 Attrite
1,000 - Fleet Qualified Aviators	

Prediction of Success in Training

Higher AQT/FAR scores are associated with a greater probability of success in training. The current test battery was initially capable of a range of predictions of success from 50 percent to 80 percent, as depicted in Figure 12-2. The average success rate for students entering training was about 70 percent, the weighted average of success predictions taking into account the numbers of students with each AQT-FAR score combination.

Table 12-3

Correlations of Selection Test Scores With Aviation Training Grades

FY 1982-1984

	Naval Aviation Schools Command Final Grade	Primary Academic Grade	Primary Flight Grade
AQT	.29	.13	.06
FAR	.21	.09	.31
MCT	.24	.08	.19
SAT	.10	.04	.19
BI	.11	.07	.27

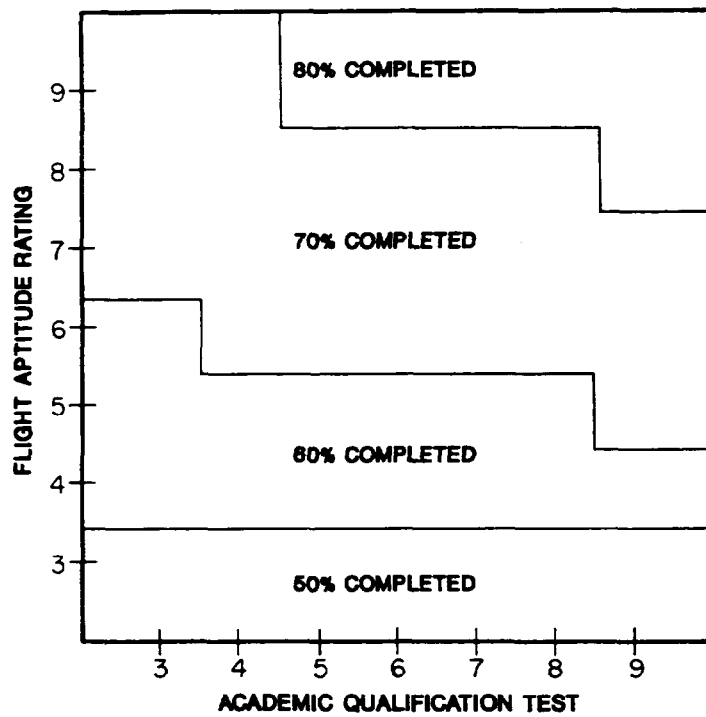

Figure 12-2. Percentage of student naval aviators completing undergraduate pilot training as a function of AQT/FAR scores, 1975.

Figure 12-3 shows the test battery's current prediction capability based on 1986 attrition data.

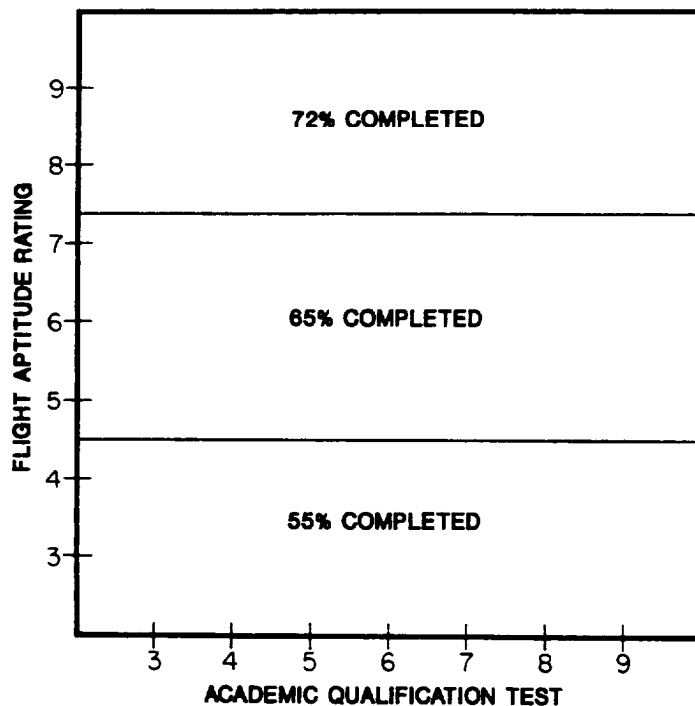

Figure 12-3. Percentage of student naval aviators completing undergraduate pilot training as a function of AQT/FAR scores, 1986.

As reported earlier, the current test battery is being revised to restore its sensitivity. There is every reason to expect a revised test battery to make predictions of success as well as or better than the earlier version.

Cost Effectiveness of the ASTB

If the aviation selection tests were not used, many unqualified or minimally qualified applicants would be admitted to training since almost half now score below required minimums. Attrition rates would certainly increase accordingly. Ten percent more attritions, a conservative estimate, would mean 200 additional attritions per year. The 200 attritions would occur at different phases of training and the more progress a student makes before attriting, the higher the cost. The cost of these 200 attritions is estimated in Table 12-4, using current cost estimates and attrition data. The figures in Table 12-4 assume that attritions would occur in training phases in the same proportion as current attritions. Attrition costs are averaged among the different pipelines.

U.S. Naval Flight Surgeon's Manual

Table 12-4

The Cost (in dollars) of 200 Student Naval Aviator Attritions

Training Phase	% of Total Attritions	Number of Attritions	Cumulative cost Per Attrition	cost Per Phase
Schools Command	67.0	134	7,500	1,005,000
Primary	20.0	40	68,200	2,728,000
Intermediate	6.5	13	228,100	2,295,300
Advanced	6.5	13	395,000	5,135,000
Total Cost of Attritions				11,833,300

Thus, a conservative estimate of 200 fewer attritions means that the current ASTB saves about 12 million dollars in training costs annually. Increases in prediction capability as a result of revising the test will save additional training dollars at the rate of six million dollars for each five percent.

Bibliography

- Examiner's manual and scoring instructions for the United States Navy and Marine Corps Aviation Selection Test* (NAMI-5098). Pensacola, FL: Naval Aerospace Medical Institute, 1982.
- Griffin, G.R. & Mosko, J.A. *A review of the naval aviation attrition research 1950-1976: A base for development of future research and evaluation* (NAMRL 1237). Pensacola, FL: Naval Aerospace Medical Research Laboratory, 1977.
- North, R.A., & Griffin, G.R. *Aviation selection 1919-1977* (Special Report 77-2). Pensacola, FL: Naval Aerospace Medical Research Laboratory, 1977.

CHAPTER 13

AVIATION MEDICINE WITH FLEET MARINE FORCES

Introduction
Personnel and Training
Organization
Medical Duties
Shipboard Deployments
Cautions
Conclusion

Introduction

The outward appearance of sameness that exists at a technical level in the Marine and Navy components of naval aviation occasionally obscures differences that are often significant. The marine aviator serving with a Fleet Marine Force works in an organizational structure which is similar to, but not identical to, that of its Navy counterpart. The marine's basic attitudes and assumptions may differ to some extent from those of his Navy peer. While a complete description of these differences and their subtle consequences is beyond the scope of this manual, it is important for any naval flight surgeon ordered to duty with the Fleet Marine Force to understand that the differences do exist. They may appear in unexpected ways; they may be subtle, and they can be ignored only at the risk of significantly reducing one's effectiveness with a Marine unit.

This chapter presents background information helpful in understanding marines and their organization. No attempt is made to discuss dispositions of specific aeromedical problems, as they rarely differ significantly from those encountered in Navy organizations.

Personnel and Training

Procurement

The Marine Corps obtains its prospective officers from a population as geographically and culturally diverse as any other service. Naval Academy graduates, as well as graduates of Naval Reserve Officer Training Corps (NROTC) programs, are commissioned in the Marine Corps.

Many marine officers enter by way of the Platoon Leaders Class (PLC), a variation of ROTC in which college students undergo two, six-week summer training sessions at the Marine Corps Development and Education Command (MEDEC), Quantico, Virginia, prior to commissioning upon graduation from college. A small, but significant percentage of Marine Corps officers are obtained from the highly competitive Enlisted Commissioning Program. These "mustang" officers bring to the Corps a depth of understanding of the enlisted community that probably cannot be obtained in any other way. Their competitiveness for advancement is limited only by their ability. In 1976, the Marine Corps promoted a man to brigadier general whose first eight years of service were as an enlisted rifleman. The current Commandant, also, began his service as an enlisted marine.

Basic Training

A distinguishing feature of the marine aviator is that his first six months of commissioned service are spent, almost without exception, as a student at The Basic School (TBS) in Quantico, Virginia. TBS provides a basic core of knowledge and experience heavily oriented toward the basic infantry mission of the Marine Corps. TBS is probably more responsible than any other factor for insuring that the proper "state of mind" will exist in all Marine Corps officers, a state that will persist despite later training as an aviation or infantry officer. In addition, this introduction to the basics of ground warfare provides the future aviation officer with an understanding of the infantry forces he will someday support.

Basic Aviation Training

Basic aviation training for Marine Corps pilots and flight officers is completely integrated with that of their Navy peers. Squadrons in the training command can be commanded by Navy or Marine officers. Most squadrons have both Navy and Marine instructors, each of whom has assigned to him students from both services. The importance of this goes far beyond cost savings or increased efficiency. Rather, it is basic to the fact that all Marine Corps pilots are indeed "naval aviators."

Advanced Aviation Training

Following basic training, a young marine naval aviator or naval flight officer (NFO) is assigned to a Marine Aircraft Wing (MAW) for training in a specific fleet aircraft. Although he is trained solely by marines in a Marine organization, NATOPS and joint training conferences insure that his training is technically the same as that received in the Navy. Following the attainment of basic qualifications in a fleet aircraft, most aviators and NFO'S are ordered to one of the three

Aviation Medicine with Fleet Marine Forces

MAW'S. If initially sent to the Second or Third MAW, located on the East Coast and West Coast respectively, he is normally transferred to the First MAW in the western Pacific during his first four years following designation as an aviator or NFO.

Further Aviation Training

Two types of later training distinguish the Marine pilot from his Navy counterpart.

Assignment To Different Aircraft. The majority of Navy pilots can anticipate a full career flying in one of the three basic communities-tactical jet, rotary wing, or patrol/transport. Not infrequently, all of a Navy pilot's flight time following basic training is logged in the same type of aircraft. A Marine Corps pilot, however, at the lieutenant colonel or colonel level, will frequently have served full tours in two or three of the basic communities, and he may have significant time in several different aircraft within a community.

Liaison Tours With a Marine Division. Each rifle battalion and rifle regiment of a Marine Division rates several fully trained naval aviators to serve as Forward Air Controllers (FAC) of Air Liaison Officers (ALO). Aviators who fill these billets are normally provided by the nearest Marine Aircraft Wing for tours of four to six months each. After spending a considerable amount of time in the field at the rifle company level, these aviators bring to infantry units the expertise to define the capabilities and limitations of the aircraft which the infantry commander might have supporting him. Individual aviators also gain an appreciation of the problems faced by infantry units which might someday call on him for support in an actual combat situation.

Organization

Fleet Marine Forces

The operating forces of the Marine Corps are currently organized into two Fleet Marine Forces (FMF): (1) Fleet Marine Force Atlantic (FMFLANT) with headquarters in Norfolk, Virginia and (2) Fleet Marine Force Pacific (FMFPAC) with headquarters in Honolulu, Hawaii. Each FMF is equivalent to a Type Command and reports to its respective Fleet Commander-in-Chief. The commanding general, a lieutenant general may be either an aviator or a ground officer. His deputy commanding general is from the other community.

Each FMF consists of at least one MAW, one Marine Division (MARDIV), and one Force Service Support Group (FSSG). Other miscellaneous supporting units may be attached. Additional-

U.S. Naval Flight Surgeon's Manual

ly, each FMF is further organized into warfighting units of combined arms known as Marine Air Ground Task Forces (MAGTF'S). MAGTF's have three different levels and consist of four separate elements:

1. A Command Element.
2. An Air Combat Element (ACE).
3. A Ground Combat Element (GCE).
4. A Combat Service Support Element (CSSE).

Although the MAGTF concept is the manner in which Marine Forces will be submitted to fight; and it is also the method by which all peacetime training exercises are conducted. Normal in-garrison evolutions are conducted based upon the Major Subordinate Command (MSC) structure of Division, Wing, and Group.

Basic Marine Corps doctrine dictates that MAGTF's will be "task organized" to the requirements of a specific mission. For example, a desert warfare task would be armor-intensive, whereas a mountain warfare task would be much less so. Similarly, a European scenario would call for maximum fixed wing and antiair capability to counter the expected threat. A jungle scenario would emphasize helicopter and VSTOL capabilities. Thus, the exact composition and size of individual MAGTF elements is, of necessity, highly variable.

The Marine Expeditionary Unit (MEU) is the smallest MAGTF. Commanded by a colonel, it contains one infantry battalion, one composite helicopter squadron (which may include AV-8B VSTOL aircraft) and a small CSSE. The MEU carries fifteen days of all classes of supplies (including Class VIII - medical and dental). But it is dependent upon the "sea based" support of the Amphibious Squadron (PHIBRON) of three or four ships from which it operates. A MEU constituted the U.S. component of the Beirut Peacekeeping Force; and, conducted the Navy portion of the Granada invasion. The MEU designated "Landing Force Sixth Fleet (LF6F)," is a constant presence in the Mediterranean. Total strength is approximately 2700 marines and sailors.

The next MAGTF level is the Marine Expeditionary Brigade (MEB). Ten to thirteen thousand strong, the MEB is commanded by a brigadier general. It carries 30 days of supplies and is capable of operations ashore independent of an ATF. Its GCE is an entire infantry regiment plus reinforcing units (i.e., armor, reconnaissance, combat engineers, etc.) The ACE consists of an entire Marine Aircraft Group whose individual squadrons will be task organized to support the mission. The CSSE is concerned with motor transport, supply, maintenance, and medical capability.

The largest MAGTF is the Marine Expeditionary Force (MEF). Commanded by a lieutenant

Aviation Medicine with Fleet Marine Forces

general, it consists of the entire Division, Wing, and Force Service Support Group. Fifty thousand strong, the MEF maintains 60 days of supplies in all classes.

FMFLANT

The aviation arm of FMFLANT is the Second Marine Aircraft Wing, whose headquarters is located at Cherry Point, North Carolina. Second MAW's tactical jets are located at Cherry Point, North Carolina and, at Beaufort, South Carolina. Helicopters are located at New River, North Carolina.

FMFPAC

FMFPAC spans the entire Pacific area, from Arizona to Japan. Headquarters, First Marine Aircraft Wing is located on Okinawa. Helicopter assets are also located on Okinawa; and, tactical jets are located at Iwakuni, Japan. The First Marine Expeditionary Brigade is located at Kaneohe MCAS (near Honolulu, Hawaii). The Brigade has smaller numbers of tactical jets and helicopters assigned, as well as an infantry element. It is, in effect, a smaller version of the normal wing/division air-ground team. The Third Marine Aircraft Wing is located in California. Headquarters and some tactical jet assets are positioned at El Toro, California. Others are located at Yuma, Arizona. Helicopters are stationed at Santa Ana and Camp Pendleton, California.

Marine Aircraft Wing

A Marine Aircraft Wing is commanded by a major general. It is important to remember that a Marine Aircraft Wing is much larger than a Navy Carrier Air Wing. Each Marine Aircraft Wing is assigned a majority of the types of aircraft in the Navy inventory. Each MAW currently has assigned F/A-18A, AV-8B, A-6E, EA-6B, OV-10D, CH-46F, CH-53 A&E, UH-1N, and AH-1T aircraft. Unlike the Marine Division which is organized along fairly standard lines, each MAW is task-organized (i.e., has different component units, depending upon the mission assigned). Typically, a Wing consists of a Marine Wing Headquarters Squadron, a Marine Air Control Group, a Marine Wing Support Group, and several Marine Aircraft Groups.

Marine Aircraft Group

Normally, a Marine Aircraft Group (MAG) consists of a Headquarters and Maintenance Squadron, a Marine Air Base Squadron, and several (nominally three to six) aircraft squadrons. Different types of aircraft usually are grouped by basic mission (e.g., tactical jet fighter, tactical

jet attack, helicopter and transport). However, variations do occur, usually because of availability of base facilities and particular training areas.

Medical Organization

Each Wing has assigned to it a senior flight surgeon (normally a captain) as the Wing Medical Officer. He is assisted by a Medical Service Corps officer, a master chief hospital corpsman, and a small office staff. The Wing Medical Officer functions on the Wing Special Staff, coordinating medical department personnel assignments, supervising the activities of assigned junior flight surgeons, assisting in the overall aviation safety program, and providing appropriate general aeromedical advice to the commanding general and the general's staff.

Junior flight surgeons are assigned by the Naval Military Personnel Command to the largest organizational unit consistent with geographic limitations imposed by Navy assignment policies. Further assignments to individual squadrons are then made by the Wing Commander, on the advice of the Wing Medical Officer. The ideal case is represented by First MAW in which all Navy personnel are assigned to the commanding general for duty. This allows for subassignment within the Wing to meet the changing needs of the command and, where possible, the desires of the individual flight surgeon.

Two important organizational differences exist between tactical air units of the Navy and Marine Corps. Because they are frequently employed independently, each Marine Squadron's Table of Organization includes a flight surgeon and usually three hospital corpsmen. Thus, the Marine Corps rates, and generally is manned, at the highest flight surgeon-to-squadron ratio in the entire aeronautical organization. Such a manning policy tremendously enhances the flight surgeon's integration into his unit and maximizes his potential contribution toward optimal combat effectiveness and aviation safety. The second major difference is a more recent development: the creation of Aeromedical Safety Officer (AMSO) billets at the HQMC, MAF, MAW, and individual Marine Aircraft Group levels. Manned mostly by designated aerospace physiologists, these individuals bring a new capability and a unique perspective to the aeromedical support effort of the command. The partnership between the flight surgeon and the physiologist is sure to reinforce the long held staff action experience that "the whole is greater than the sum of its parts."

In addition to designated flight surgeon billets, there is the potential for flight surgeons to be assigned to the MAGTF Headquarters as the MEU (LT/LCDR), MEB (CDR), or MEF (CAPT) surgeon. Similarly, assignments for captains to the Headquarters of the FMF or any of the Major Subordinant Commands are possible. Most such staff positions involve considerations well

Aviation Medicine with Fleet Marine Forces

beyond purely aviation medicine, and offer interested officers a broad perspective and distinct challenge which incorporates the entire spectrum of FMF medical support.

Medical Duties

The general duties of a flight surgeon attached to a Fleet Marine Force can be grouped into five broad categories.

Outpatient Clinical Medicine

Depending upon the unit to which attached and the arrangements made by the local command, some percentage of the flight surgeon's time normally will be spent in an outpatient medical facility, either at an outlying clinic or in the outpatient department of a naval hospital. The patient mix - active duty aircrew, active duty nonaircrew, dependent, and retired - will depend on the locality. Under such circumstances, the flight surgeon works under the professional direction of the clinic senior medical officer or the chief of the department.

Aviation Medicine Department

Depending upon local arrangements, the aviation medical department or the aviation examination room might be involved in aircrew physical examinations, aircrew sick call, or both.

Squadron Time

Normally, one will be assigned to one or more squadrons, and possibly to the group as well. This presents a challenge in the management of time. It will be necessary to cover many areas of responsibility without spending too much time in any one place. There will be presentations at all officer meetings (AOM's). At the squadron level, it is not enough to know all of the pilots personally. One should also have an understanding of the unit safety program and of programs that are currently being emphasized by the command - programs that may have little to do directly with safety, but which may influence safe flight operations by their effect on the state of rest and morale of aircrew personnel. In addition, a flight surgeon should log some amount of time flying with the squadron.

Attention should be paid to enlisted work spaces, particularly the maintenance shops. Not only do these maintenance areas contain significant industrial hazards, but the maintenance effort is also not likely to be better than the men doing the job.

Field Training Exercises

Marine squadrons of all types participate in field exercises supporting various units from the Marine division. Under such circumstances, the flight surgeon frequently has overall medical responsibility for the health and sanitation of all personnel living in a camp as well as his normal aeromedical concerns. Although preventive medicine technicians attached to the wing medical officer's office can provide invaluable assistance and technical guidance, there is no substitute for becoming involved at an early stage in the planning of the exercise. The flight surgeon should understand clearly what the camp commander expects. The commander, should understand clearly what can and cannot be provided. Availability of back-up medical services, patient transportation, definition of patient categories leading to evacuation, chain of command for approving medical evacuation, anticipation of peculiar medical problems, and medical supply should all be considered and planned for in advance. If possible, there should be a discussion with the medical officer who went on the last exercise. If this is not possible the "lessons learned" report which he submitted should be closely examined. Each flight surgeon should document his own experiences and insure that they are included in the command's after-action report.

Shipboard Deployments

The Amphibious Forces

The Navy's amphibious forces, of which the LPH and LHA are parts, are tasked with moving troops, equipment, and supplies from sea to shore in order to secure a desired objective. The term amphibious derives from two Greek roots (i.e., "amphi," meaning "on both sides" and "bios," meaning "life"). The classic symbol of the amphibious forces has been the alligator, a characteristically fearless fellow, very well adapted to "living on both sides."

Naval ship designations have given the letter L (landing) to all vessels of the amphibious force. Several types of amphibious ships have evolved over the years, each uniquely configured and suited to its own particular role in the tremendous complexity of an opposed assault from the sea. Examples of amphibious ships are given in Table 13-1.

It is probably safe to say that no sea-going community contains as many varied ship types and individual missions as the Navy amphibious forces.

Formerly one of eight Fleet-type commands (TYCOM), the amphibious forces are now combined with the destroyer, service, and mine forces, as shown in Table 13-2 into a large consolidated TYCOM, Commander Naval Surface Forces Atlantic (SURFLANT) and Pacific

Aviation Medicine with Fleet Marine Forces

(SURFPAC). Like the major carrier, submarine, and FMF TYCOMS, SURFLANT, and SURFPAC report directly to their respective Fleet Commanders, who in turn report directly to the Chief of Naval Operations.

Table 13-1

Ship Types of the Amphibious Force

Type	Designation	Tons Displacement
Inshore Fire Support Ship	LFR	7,000
Tank Landing Ship	LST	7,800
Amphibious Command Ship	LCC	10,500
Amphibious Cargo Ship	LKA	10,600
Amphibious Transport Ship	LPA	20,600
Dock Landing Ship	LSD	11,500
Amphibious Transport Dock	LPD	17,000
Amphibious Assault Ship	LPH	18,000
General Purpose Assault Ship	LHA	40,000

Table 13-2

Fleet Type Commands

Past	Present
Amphibious Forces	
Cruiser - Destroyer Forces	
Service Forces	Surface Forces
Mine Forces	
Fleet Marine Forces	Fleet Marine Forces
Naval Air Forces	Naval Air Forces
Submarine Forces	Submarine Forces
Training Commands	

U.S. Naval Flight Surgeon's Manual

The amphibious assault ship (LPH) and the general purpose assault ship (LHA) are, in every sense, aircraft carriers. There are more similarities than differences between these ship types and the more familiar CV types. Basic to both is their primary mission of transporting, launching, recovering, and maintaining their particular aircraft mix in order to accomplish the objective at hand. Other ship types carry aircraft, however, their primary missions revolve around other tasks, and their aircraft are used only in a supporting or auxiliary role. Far from being supporting or auxiliary, a carrier's embarked aircraft are its very reason for existence.

The rapid development of helicopter technology and capability since World War II has been the primary stimulus to the development of amphibious assault ships, also known colloquially as "helicopter assault ships" or "helicopter carriers." The concept of vertical envelopment from the sea is of tremendous importance in amphibious operations because:

1. Airborne troops are not dependent upon favorable beaches (unfavorable ones were responsible for horrendous casualties at Tarawa and in certain sectors of the Normandy landings).
2. The landing force can become established ashore more quickly.
3. More dispersal of the landing force is feasible, thus eliminating large concentrations of men and equipment on the landing beach.

The first ships to be configured for this amphibious assault role were World War II vintage Essex-class carriers, none of which are currently used in this manner. In addition to various deck, weapons spaces, and aircraft maintenance modifications, accommodations for a Marine Battalion Landing Team of 1500 men were made. So successful was the LPH concept, in training exercises as well as in several contingency operations, that a new ship type was specifically designed to support this assault concept.

As Table 13-3 shows, the LPHs, listed in Table 13-4, are approximately one-half the size of their Essex-class predecessors. Present doctrine calls for the embarkation of the major portion of a MEU of 2500 men, including an entire squadron of medium assault transport helicopters (12 CH-46's) supplemented by detachments of heavy lift CH-53's, and AH-1 gunship helicopters for the usual amphibious training exercise or regularly scheduled Mediterranean deployment. When the newer LHA's are used for such purposes, fixed wing attack capability (AV-8) is frequently added to the composite squadron. As Table 13-3 also reveals, these vessels more closely approximate Essex-class CV's in size, and add the important capability of a well deck for the embarkation and debarkation of assault amphibian vehicles. The remainder of the MEU's assets are

spread over two or three other amphibious ships (LST, LKA, LSD), all of which together constitute the Amphibious Squadron (PHIBRON).

Table 13-3

Comparison of Essex-Class CV with Iwo Jima-Class LPH and Tarawa Class LHA

	Essex	Iwo Jima	Tarawa
Displacement, Tons	40,600	18,000	39,300
Length	894	602	820
Beam	202	84	107
Draft	31	29	27
Shaft H.P.	150,000	22,000	70,000
Accommodations	3,200	2,500	2,630

A major difference in newer LPH and LHA design has been a quantum leap in medical capability. Whereas the Essex-class CV's had a hospital bed capacity of approximately 30, the modern assault ship boasts a modern, well-equipped hospital with contiguous expansion capability of approximately 150 beds, and all of the medical support capability of the largest CV. This unusually large capability in a ship of relatively small size is seen as a direct outgrowth of modern helicopter capability; the rapid airborne insertion of a landing force and the equally rapid air evacuation of battle casualties has been combat-proven and, in effect, mandates a secondary role of "mini-hospital-ship" to the LPH and LHA.

Shipboard organization in the LPH community is essentially the same as that described for aircraft carriers in Chapter 14. The medical support organization for forces afloat is a very close parallel, excepting the names of the respective TYCOM's.

An important organizational difference exists, however, in the relation of the assault ship and her embarked Marine Corps units. During an amphibious operation, the Marine Air Ground Task Force commander is designated "Commander Landing Force" (CLF). He retains operational control over his Ground Combat Element, Air Combat Element, and Combat Service Support Element, at all times. While embarked, and until the Landing Force is established ashore in the Amphibious Objective Area (AOA), he reports to the Navy "Commander, Amphibious Task Force" (CATF). The size of the ATF is, naturally, determined by that of the LF, and may

vary from three or four ships for a MAU to as many as 50 for an entire MAF. Finally, the particular MAGTF embarked will be determined by the particular mission envisioned.

Table 13-4

LPH's and LHA's in Commission

LANTFLT	PACFLT
USS Raleigh (LPH-1)	USS Okinawa (LPH-3)
USS Iwo Jima (LPH-2)	USS Tripoli (LPH-10)
USS Guadalcanal (LPH-7)	USS New Orleans (LPH-11)
USS Guam (LPH-9)	USS Tarawa (LHA-1)
USS Inchon (LPH-12)	USS Belleau Wood (LHA-3)
USS Saipan (LHA-2)	USS Pelieu (LHA-5)
USS Nassau (LHA-4)	

Assault Ship Medical Department

The assault ship medical department organization and facilities are, with a few exceptions, essentially the same as described for aircraft carriers (CV's) in Chapter 14, *The Aircraft Carrier*.

The ship's surgeon is generally a post GME-1 medical officer serving his initial operational assignment. He may or may not have had surgical training. There has been much interest in designating assault ship medical officer positions as flight surgeon billets, but for valid reasons this ideal has proved elusive. The ship's surgeon is assisted by a chief hospital corpsman and 15 to 20 HM's of various Navy Enlisted Classifications (NEC's).

Currently, the embarked helicopter squadron brings aboard a flight surgeon from its parent Marine Aircraft Group. He is primarily responsible for the aeromedical support of the embarked Air Combat Element and normally remains with them for the duration of the cruise (three to six months). He is generally accompanied by three corpsmen. His relationship in the overall deployment scheme is exactly that of his CV colleague.

Aviation Medicine with Fleet Marine Forces

The Marine Battalion presently embarks with approximately 44 corpsmen. During at-sea periods, these corpsmen work in the medical department, although they remain an integral part of their Ground Combat Element and will accompany it during any real or simulated assault.

The Combat Service Support Element is usually a MAU Service Support Group (MSSG), and embarks one medical officer and 20 HM's. Rather than the Aid Station equipment and consumables carried by the ACE and GCE, the MSSG embarks the equivalent of one-half of a Medical Company (i.e., one operating room, 30 beds, triage, blood bank, X-ray, laboratory, and pharmacy). Keeping in mind the "task organization" employment of Marine forces, a larger MAGTF may require several entire Medical Companies.

During every assault ship deployment, a predesignated surgical team from a naval hospital is embarked with ample consumable material, thus rounding out a very impressive medical capability (see Table 13-5).

Table 13-5

Composition of a Surgical Team

1 General Surgeon
1 Orthopedic Surgeon
1 Anesthesiologist
1 Medical Administration Officer
1 Nurse Anesthetist
1 Operating Room Nurse
1 General Service Hospital Corpsman
1 Clinical Lab Technician
1 Medical Service Technician (HMC)
1 X-ray Technician (HMC or HMI)
5 Operating Room Technicians
1 Orthopedic Cast Room Technician

Since the LPH and LHA are intended to support as well as to deploy their MAGTF, the medical spaces have been designated specifically to receive and treat large numbers of battle casualties. In addition to the wide passageways present in the larger CV types, the LPH and LHA boast several unique attributes. There are two fully equipped operating suites and a minor surgery area which can be quickly rigged to handle major cases. Full blood banking facilities are capable of processing large volumes rapidly. Several intensive care beds are available with full monitoring

and life support capability. The fixed 30-bed ward is continuous with troop berthing spaces allowing immediate expansion to a full-bed capacity of 150 plus.

When actual casualties are inbound to an LPH, designated litter handling teams are called to the flight deck where they are met by the triage officer (normally the flight surgeon). As he enters the aircraft with his teams, the triage officer begins the sorting process which continues, with frequent revisions, to the deck edge elevator and then down to the casualty holding area aft of the hangar deck. From this holding area where emergency treatment is begun, patients are selectively brought by a special "patient" elevator to the medical department spaces on the 01 level, immediately above. Thus, casualties are moved rapidly, and entry into medical spaces is rigidly controlled so as to maximize the quality of care for the greatest number.

Medical spaces in the LHA are configured differently, with ready access from a large flight deck elevator as well as directly from the well deck.

Many teams have found it advantageous to rotate medical officers' responsibilities on different days of an operation, within obvious limits. Thus, each officer is able to view the operation from different vantage points. During such an operation, the flight surgeon is sure to find ample opportunity to hone his surgical skills under well-qualified supervision.

Major disaster relief operations provide yet another exciting and rewarding opportunity for the assault ship and her embarked aircraft to serve the national interest in a wholly different manner. It is difficult to imagine a vessel more ideally suited for this particular task than the LPH or the LHA.

Assignment to an LPH or LHA deployed helicopter squadron provides a flight surgeon with a unique opportunity to participate in some of the most varied and demanding aviation activities found anywhere. Modern helicopters lend themselves to a multitude of missions (e.g., troop transport, resupply, medical evacuation, search and rescue, air reconnaissance or recon team insertion and extraction, underway vertical replenishment, aircraft and equipment recovery, attack, and fire suppression).

The helicopter, with its impressive capabilities, has brought the flight surgeon into the amphibious forces; present as well as future development are certain to keep him there. The new 40,000 ton general purpose assault ships (LHA), of which five are now in commission, promise to outstrip the LPH in terms of aircraft handling ability, not to mention the carrying of troops, cargo, and heavy assault vehicles, and casualty care. The advent of VSTOL aircraft and their recent trial deployments aboard amphibious force ships adds a whole new dimension to this rapidly

evolving fleet capability. Current interest in smaller CV types for future attack and antisubmarine forces will strengthen the fledgling union between the VSTOL community and the amphibious forces. Finally, the steady decrease in U.S. forces stationed abroad highlights our nation's dependence upon forces afloat to project American policy throughout the world. All of these factors point to the increasing importance of the amphibious forces in general and to the LPH and LHA types in particular.

These ships, especially the latter, have a definite and readily apparent need for the flight surgeon's unique operational and medical expertise. Fleet readiness would be well served by the permanent assignment of flight surgeons to LPHs and LHAs, on the same basis as their current assignment to CVs.

Cautions

Conduct

Marines are tremendously proud of their heritage. As such, they normally respond very favorably to a medical officer who wears his uniform with pride, conforms to grooming standards, maintains their pace in physical conditioning, and generally conducts himself in the manner expected of a young marine officer. Because they respect their profession, they naturally will respect the flight surgeon's, provided he remembers what it is. His job is to give marines professional medical advice tailored to the unique requirements of their society and their mission. His job is *not* to be a pilot or flight officer, a squadron commander, or a tactical expert.

Rank and Forms of Address

Just as in a hospital, forms of address for different personnel have evolved in the Marine Corps. The flight surgeon should learn them and become comfortable using them. Although some of the conventions may seem somewhat rigid, they nevertheless serve a subtle but important purpose. They tend to remind one that in a structured system, one's relation to another is largely defined by the mission and the requirements of the job, not by one's personal friendships. This does not mean that a more informal approach cannot be used when called for by one's role as a physician. Rather, it suggests that this should be the justification in specific cases, rather than a blanket excuse to ignore one's position as a naval officer.

Enlisted. All enlisted personnel can be properly addressed by rank, with or without last name attached. Gunnery sergeants (pay grade E-7, equivalent to a chief petty officer) are almost universally addressed as "Gunny." First sergeants and master sergeants (both pay grade E-8) are usually

U.S. Naval Flight Surgeon's Manual

referred to as "Top." Master gunnery sergeants (E-9) are also often referred to as "Top." Most importantly, a sergeant major (E-9) is referred to in only one way - "Sergeant Major." The term "sarge" is occasionally used, but is improper and should be avoided. The term "sir" is never used in talking to enlisted personnel; it will frequently be interpreted as a put-down and will have an effect opposite to that intended.

Warrant Officers. Marine warrant officers are referred to as "Gunner."

Commissioned Officers. Officers junior to the speaker are referred to by their rank and last name. Officers of the same rank are generally referred to by their first name. Officers senior to the speaker are never referred to by their first name, unless it is specifically requested by the senior officer.

Conclusion

Marines are challenging, stimulating, and rewarding to work with. For a flight surgeon, a Marine assignment represents as wide a variety of aviation and aeromedical experience as can be found in any command. The Marine organizational structure places emphasis on strong central command. However, it allows an individual great latitude and initiative in exercising ideas with the potential for far-reaching effects. An assignment to a Fleet Marine Force is a rewarding experience a flight surgeon is not likely to forget.

CHAPTER 14

THE AIRCRAFT CARRIER

Introduction
History
Mission
Types of Aircraft Carriers
Medical Support Organization for Forces Afloat
Shipboard Organization
The Medical Department
The Cruise Cycle
The Air Wing Flight Surgeon
Summary

Introduction

While this chapter is devoted to the aircraft carrier, one must remember that it is not the only vessel with aviation units on board. Assault ships, such as LPH's and LHA's, have helicopters assigned to them for the transport and the support of Marine battalions ashore (see Chapter 13, *Aviation Medicine with Fleet Marine Forces*). Supply vessels and ammunition ships carry helicopters for vertical replenishment (VERTREPS) of other seagoing ships. The SH-2F "Sea Sprite" helicopter is used aboard destroyers in a program called LAMPS (Light Airborne Multipurpose System). VSTOL (Vertical and Short Take-Off and Landing) aircraft are already a reality aboard the carrier and are a forerunner of the future.

History

The first carrier, the USS *Langley*, was commissioned in 1922. At 534 feet in length, it was half as long as today's super-Nimitz class carriers. *Langley* based aviators initiated pioneering developments in carrier aviation, including sea reconnaissance, dive-bombing, and aerial torpedo delivery.

No longer requiring fixed runways to support forward based naval assets, the Navy now had a limited ability to take aircraft in harm's way offshore in war at sea and in operations supporting

U.S. Naval Flight Surgeon's Manual

ground-based initiatives anywhere in the world. The first carriers were limited only by the supply lines supporting them.

Most of the early carriers were built from converted heavy cruisers left over from World War I. By 1934, the first three Essex class carriers were constructed from the keel up. The fleet had six carriers by the onset of World War II, and nearly 80 afloat at the War's end.

During World War II, United States Navy aircraft carriers were important in safeguarding sea lanes in the Atlantic, however, carriers made their most significant contribution in the Pacific Theater. Carrier battle groups provided the primary striking power as the United States engaged Japan throughout the far reaches of the world's greatest ocean. The Doolittle Raid against Tokyo was launched from the deck of the USS *Hornet* early in the war, and carrier battle groups were the crucial factor in the victories at Coral Sea, Midway, the Marianas and Leyte Gulf. Likewise, carrier battle groups made possible the "island hopping" strategy in the Central Pacific, culminating in the successful amphibious assaults against of the islands of Okinawa and Iwo Jima.

An offshoot of wartime technology was the jet engine. Once a commitment had been made to develop naval aircraft powered by this type of engine, it required little time to realize that existing carrier design would not support these new airframes. Most of the light carriers (attack and escort varieties) were not suitable for conversion. However, several of the larger carriers did have the characteristics necessary for conversion to a platform capable of supporting jets. Between 1947 and 1953 a modernization program was started. Improvements included stronger catapults, angled decks portside, longer decks, and the ability for special weapon delivery.

During this transition, the United States went to war in defense of South Korea against North Korean aggressions. Carrier aviation assets again proved invaluable as a support element for ground-based operations. Carrier-based forces were successfully used to strike strategic and tactical targets far inland, later leading to meaningful peace talks with North Korea.

At the same time, three new classes of aircraft carriers were being developed. They included two conventionally-powered (CV) classes (Forrestal and Kitty Hawk) and one nuclear-powered (CVN) class (Enterprise). Most of these hulls were commissioned in time to see extensive action in Vietnam. By 1968, almost one-half of the combat missions flown over North Vietnam were from the decks of carriers. Carrier-based strikes were also conducted regularly over South Vietnam in support of ground-based and air combat missions (both strategic and tactical "surgical strikes").

The Aircraft Carrier

At the end of the Vietnam era, the first of the Nimitz Class carriers came on line. Since 1972, four more have been added to the fleet and one more is under construction. At present, these will probably be used to replace aging aircraft carriers, and they will serve as the nucleus of the proposed 15 carrier-based battle groups. With changing concepts of future warfare turning away from global conflict and towards the "little war" model; and in light of recent political changes reflected in Gramm-Rudman budget cuts, it is unlikely that any major changes or additions to carrier-based assets will be made in the foreseeable future.

Mission

Six of the 15 currently commissioned carriers are CVN's. All 15 support antisubmarine warfare (ASW) operations with at least one ASW helicopter squadron and a fixed wing ASW squadron aboard, as well as serving the more traditional roles of fleet air defense and attack missions (bombing). Most carrier air wings (CVW's) are configured with nine squadrons and a detachment of photo reconnaissance aircraft. Carriers defend themselves with their speed (in excess of 28 knots), with missile batteries of surface-to-surface and surface-to-air missiles (point defense), and with the extended umbrella of carrier air wing fighters performing barrier or force combat air patrols (BARCAP and FORECAP) at some distance from the ship.

Configured as an attack ASW carrier, the various missions of the aircraft carrier become more apparent. Conceptually, the carrier encompasses both tactical and strategic defensive and offensive capabilities. Offensively, it can wage conventional or nuclear war or deter such warfare by its presence. It attracts military attention wherever it goes, thus diverting potential military offensive resources that could be employed elsewhere. It serves as an integrating vehicle for surface warships in company, aircraft deployed overhead, and attack submarines working below. Combining the advantages of each of the air, surface, and subsurface capabilities, threats can be neutralized quickly to both tactical and strategic advantage. This three-dimensional coverage for fleet offense and defense, coupled with modern electronic hardware and software technology, provides an unparalleled tactical and strategic capability.

The current carrier is large. In effect, it is a city of from 4,500 to 6,000 persons. It sleeps, feeds, and employs personnel 24 hours a day, seven days a week. It has from four to eight messing facilities, three barbershops, a church, a library, a small gymnasium, a 45-plus bed hospital, makes 600,000 to 800,000 gallons of fresh water daily, and serves as its own airfield.

The many facilities of an aircraft carrier allow it to act as a support and evacuation platform in times of war or civil disaster. In the evacuation of Vietnam, the earthquakes in Peru, and the floods of the Phillipines, carriers and assault ships such as the USS *Midway* (CV-41) and USS *Guam* (LPH-9) figured prominently in providing relief to beleaguered civilian populations.

Medical personnel assigned to aircraft carriers are tasked with the support of this floating city and all ships in company with it. The physician afloat is expected to be ready for any eventuality. Over the history of the carrier, this requirement has resulted in an expansion of the facilities and equipment available to the point that aircraft carriers now have some of the finest medical facilities afloat.

Types of Aircraft Carriers

There are six basic aircraft carrier types, as seen in Table 14-1. Size is the obvious characteristic differentiating aircraft carriers; the Essex class carriers at 38,000 tons displacement are the smallest, so small that they cannot handle some of the aircraft in today's naval aviation inventory. The largest are the nuclear-powered, Nimitz class carriers at 95,000 or more tons displacement. All aircraft carriers have angled decks to facilitate simultaneous launch and recovery, particularly the latter, and all have from two to four steam catapults. All carriers use the Fresnel lens landing system and three to four crossdeck pendants attached to braking engines for recovering aircraft. The launch and recovery system of an aircraft carrier allows it to accelerate a 75,000 pound object to 150 mph in 300 feet, or stop the same weight going 160 mph in 400 feet.

Medical Support Organization for Forces Afloat

Aircraft carriers on each coast report to their respective Type Commander (TYCOM) for matters that pertain to the function of the carriers themselves (Figure 14-1). On the East Coast, this is the Commander, Naval Air Forces, Atlantic Fleet COMNAVAIRLANT, located in Norfolk, Virginia, who in turn reports to the Commander-in-Chief, Naval Forces, Atlantic Fleet (CINCLANTFLT), who reports to the Chief of Naval Operations (CNO). On the West Coast this chain is similar. The Type Commander for aircraft carriers is COMNAVAIRPAC, located at North Island, San Diego, and the Fleet Commander is CINCPACFLT, located in Hawaii. When carriers deploy overseas, they leave the immediate purview of their Type Commanders, retaining only an administrative link for functional purposes. The carrier brings with it its operational commander, who comes from the Fleet Commander's staff. His title is Carrier Group Commander (COMCARCRU), with the rank of rear admiral. When reaching the Sixth Fleet (Mediterranean) from the East Coast or the Seventh Fleet (Pacific) from the West Coast, the carrier group acquires other ships in company and becomes a task group. The senior carrier group commander, if two or more carriers are deployed in a specific fleet, is the task force commander.

The Aircraft Carrier

Table 14-1

Aircraft Carriers in the Active Fleet

Class	Hull No.	Ship	Commissioning	Tons	Home Port
Essex	AVT-16	USS Lexington	1943	38000	Pensacola, FL
Midway	CV-41	USS Midway	1945	45000	Yokosuka, Japan
Forrestal	CV-59	USS Forrestal	1955	80000	Mayport, FL
	CV-60	USS Saratoga	1956	80000	Mayport, FL
	CV-61	USS Ranger	1957	80000	San Diego, CA
	CV-62	USS Independence	1959	80000	San Diego, CA
	CV-63	USS Kitty Hawk	1961	80000	San Diego, CA
	CV-64	USS Constellation	1961	80000	Alameda, CA
	CV-66	USS America	1965	80000	Norfolk, VA
	CV-67	USS Kennedy	1968	80000	Norfolk, VA
Enterprise	CVN-65	USS Enterprise	1961	90000	Alameda, CA
Nimitz	CVN-68	USS Nimitz	1975	95000	Bremerton, WA
	CVN-69	USS Eisenhower	1977	95000	Norfolk, VA
	CVN-70	USS Vinson	1982	98500	Alameda, CA
	CVN-71	USS Roosevelt	1986	98500	Norfolk, VA
	CVN-72	USS Lincoln	1990	98500	Norfolk, VA
	CVN-73	USS Washington	1991	98500	Norfolk, VA

The Type Commander has a force medical officer on his staff who is responsible for insuring general medical readiness of all of the carriers under the TYCOM preview. This includes appropriate manning, equipment, supply, training, and shipboard environmental health. By generating medical policy, observation of performance, and frequent inspection, the force medical officer assists in maintaining operational readiness in the carrier force. The force medical officer also maintains liaison with the fleet surgeon on the fleet commander's staff.

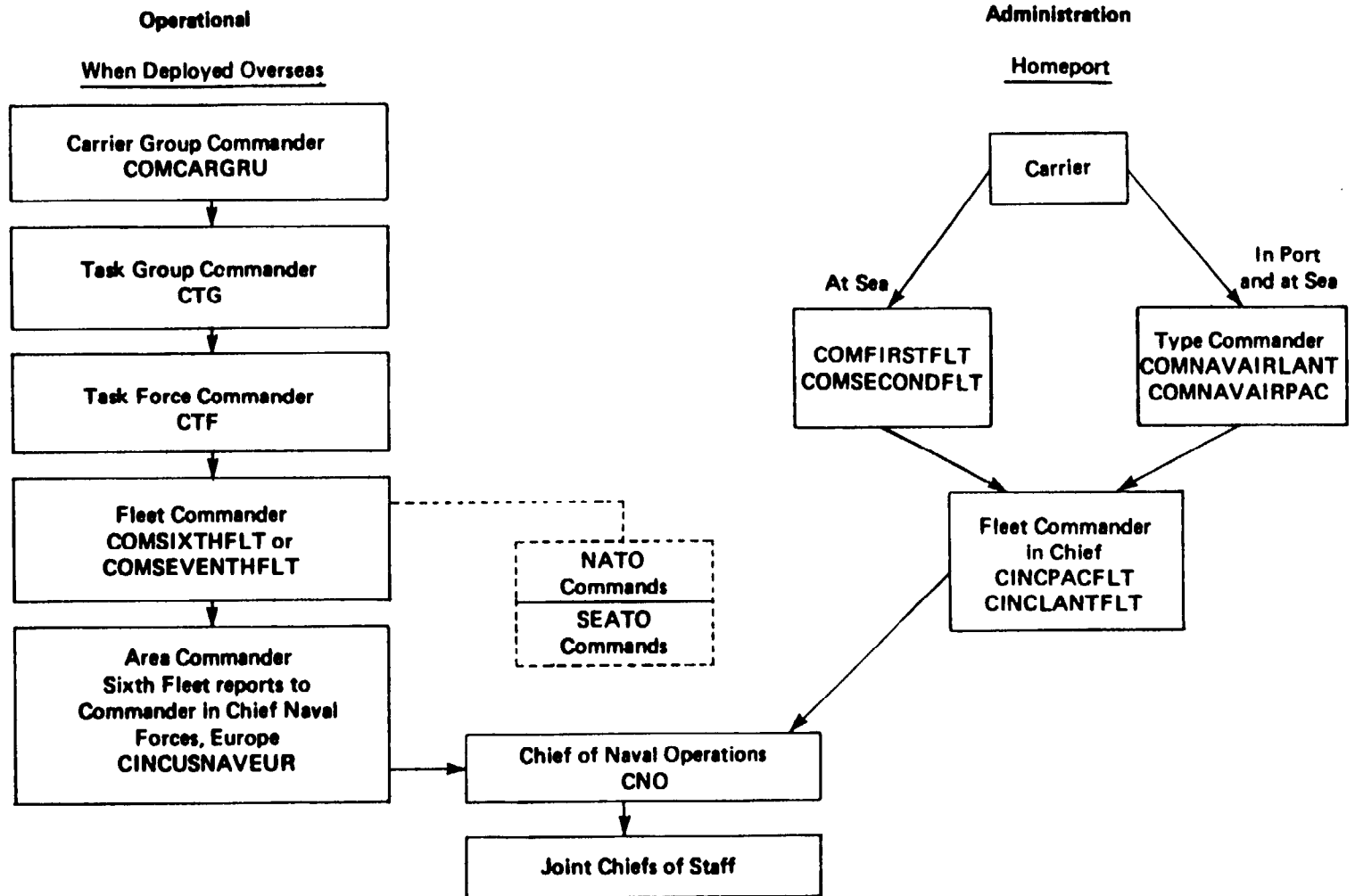

Figure 14-1. Operational chain of command.

The Aircraft Carrier

The senior medical officer (SMO) aboard an aircraft carrier is usually a commander and is a designated naval flight surgeon. He usually has had several tours, one of which has been as an air wing flight surgeon. Typically, he has completed a residency in aerospace medicine and is board certified or board eligible in preventive medicine.

When deployed, the SMO of a carrier is attached to the embarked flag's officer's staff to assist in the medical planning required to support operations for all ships in company or under operational control of the admiral. It is the SMO's responsibility to be aware of and know how to use all shore-based medical facilities in his area, the most expeditious and appropriate medical evacuation routes available in the area of planned operations, all medical personnel and material available afloat, and how to best support planned operations. The SMO has to establish liaison with shore-based medical facilities and other task force medical assets, when available, if joint operations are planned that require medical support. This kind of planning is necessary and may require liaison with the fleet surgeon assigned to the Sixth or Seventh Fleet Staff.

Shipboard Organization

Aircraft carriers maintain the same functional organizational relationships traditional on all naval vessels. All department heads report to the commanding officer regarding their specific function. They report via the executive officer to the commanding officer for administrative matters under their cognizance. In the SMO's case, he reports to the commanding officer on all matters pertaining to the health of the crew.

As Figure 14-2 indicates, the medical department shares the same status aboard ship as the other departments. Shipboard policy and procedures are promulgated by the department heads, all senior naval officers. Often these men come aboard having served as squadron commanding officers or on air wing staffs. The department heads form an executive board that advises the command on policies and procedures, especially in matters involving the crew.

The Medical Department

Manning

Medical department manpower requirements are established through certain ratios (one physician per 1200 personnel and one corpsman per 150 personnel aboard ship), specialty Navy enlisted classification (NEC) needs, and the specific assignment of corpsmen and flight surgeons to the carrier air wing. Table 14-2 depicts this breakdown. The third column indicates the assets that the air wing brings aboard when it is embarked.

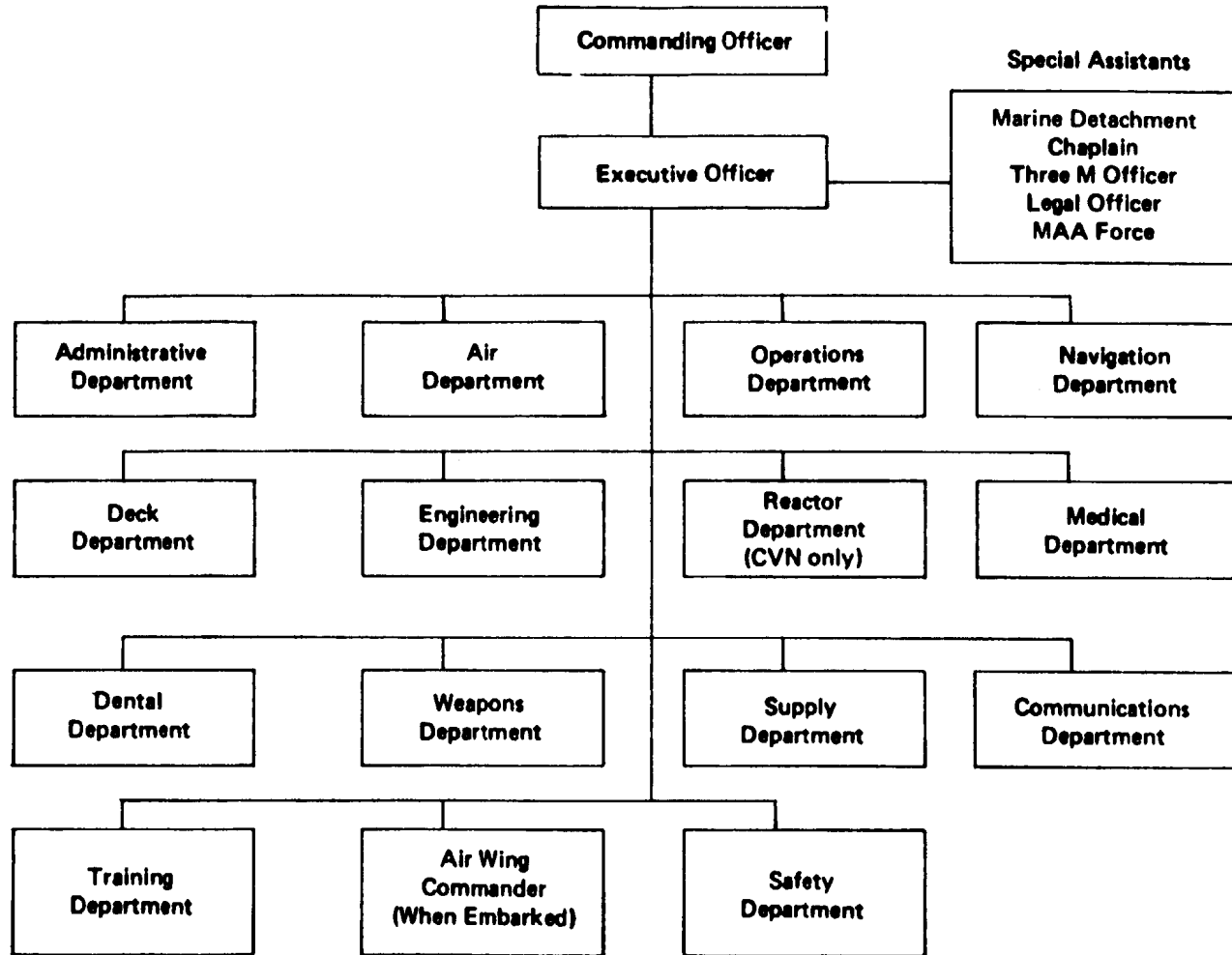

Figure 14-2. Shipboard organization chart.

The Aircraft Carrier

Table 14-2

Medical Department Manning

	FORRESTAL Class Ship's Company Assets	NIMITZ Class Ship's Company Assets	Air Wing TAD Embarked Assets
Senior Medical Officer	1 CDR	1 CDR	
General Surgeon	1 LCDR	1 LCDR	
Flight Surgeon			2 LT or LCDR
General Medical Officer	1 LT	1 LT	
Medical Administration Officer	1 LT	1 LT	
Nurse Anesthetist	1 LT	1 LT	
Chief Petty Officers	2 (1 HMCS)	2 (1 HMCS)	
First Class Petty Officers	4	5	6
Second Class Petty Officers	6	7	5
Third Class Petty Officers	7	7	4
Nonrated Hospital Corpsmen	8	8	
Total Officers	3	3	2
Total Enlisted	27	29	15

Table 14-3 shows the Navy enlisted classifications represented aboard an aircraft carrier. These individuals have had specific training beyond Hospital Corps "A" School or experience in particular duties, especially involving shipboard life. This group of permanent personnel is augmented by squadron Hospital Corps personnel when the air wing is embarked to bring the total number of paramedical technicians more into line with the needs of the ship. It is these men who allow the medical department of an aircraft carrier to provide its many services to the ship.

Organization

The requirements for shipboard organization are spelled out in OPNAVINST 3120.32 series and in CV SHIPINST 5400.1 series. Virtually all carrier medical departments have the features required in these instructions. Literally, a medical department is structured and operated like a miniature naval hospital. The medical officer has two principal assistants. One handles administrative or "staff" functions and the other directs the professional services or "line" functions of the department.

U.S. Naval Flight Surgeon's Manual

Table 14-3

Navy Enlisted Classification Specialists in a Carrier
Medical Department (Ship's Company Only)

Title	NEC	Allowances					
		E-8	E-7	E-6	E-5	E-4	E-3
General Service	HM 0000	1	1	2	3	3	9
Aerospace Medicine Technician	HM 8406				1		
Nuclear Medicine Technician*	HM 8407			1			
Medical Services Technician	HM 8424			1			
Preventive Medicine Technician	HM 8432			1			
X-Ray Technician	HM 8452					1	
Pharmacy Technician	HM 8482				1		
OR Technician	HM 8483					1	
Laboratory Technician	HM 8501				1		
Advanced Laboratory Technician	HM 8506				1		
	TOTALS	1	1	5	7	5	9

*CVN only

Although the basic instructions governing a "Table of Organization" are promulgated to allow each ship flexibility in structuring and operating its departments, the medical departments of most aircraft carriers are organized as Figure 14-3 indicates, with only minor variations. The manner in which this organization accomplishes the mission of the department is described in Figure 14-4. This figure shows the functional operation of a medical department, with a division of responsibility into seven broad areas. The SMO usually takes direct supervision of environmental health, preventive medicine, and aviation medicine. The assistant medical officer supervises all clinical services and reports to the SMO on performance in these areas. The medical administrative officer, assisted by the medical department's senior enlisted man, manages and supervises all of the departmental support functions.

Figure 14-4 is also useful because it describes the extent of involvement of the medical department in the daily routine of the ship.

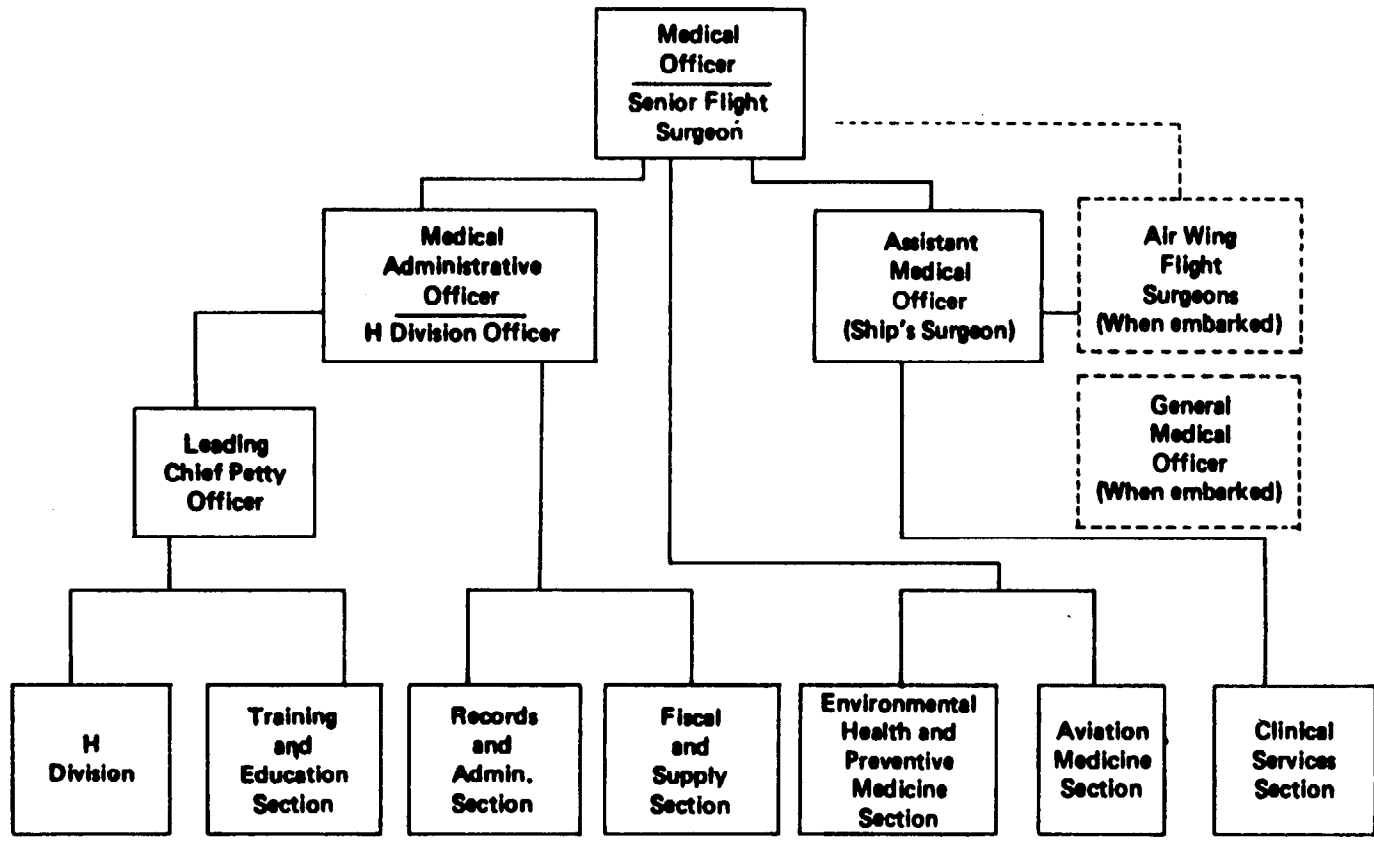

Figure 14-3. Medical department organization chart.

Administrative Services
Professional Services

H DIVISION	TRAINING AND EDUCATION SECTION	ADMINISTRATION AND RECORDS SECTION	FISCAL AND SUPPLY SECTION	ENVIRONMENTAL HEALTH AND PREVENTIVE MEDICINE SECTION	AVIATION MEDICINE SECTION	CLINICAL SERVICES SECTION
Leading Petty Officer (L.P.O.)	H Division Training P.O.	Administrative Assistance	Medical Property	Shipboard Sanitation Program	Physical Exams	Sick Call
Damage Control Petty Officer (DCPO)	Shipboard Training P.O.	Medical Records	Budget Planning	Shipboard Potable Water Monitoring	Eye Clinic	Emergency and Treatment Room
3M Coordinator	Command Training Team P.O.	Radiation Health Program	Accounting	Pest and Rodent Control Program	ENT Clinic	Surgical Preparation and Operating Rooms
Human Goals Rep.	Damage Control P.Q.S.	PRP Program	Procurement Management	Shipboard Toxicology and Hazardous Materials Program	Audiology	Medical Ward
Career Counselor	3M P.Q.S.	Consultations and Referrals	Other Procurement and Open Purchase	STD Control Program	Sight Safety Program	Intensive Care Unit
Drug Exemption Representative	Medical Dept. P.Q.S.	Emergency Care Billing	Stock Management	TB Control Program	Weight Control Program	Pharmacy
H Division Sect. Leaders	Corpsmen Eval. Board	Insurance Inquiries	Personal Emergency Equipment Inventory	Immunization Program	Aviation Medicine	Laboratory
Watch Quarter Station Bill	Medical Dept. Library	CHAMPUS Advisory	Medical Equipment Planned Maintenance System	Heat Stress Prevention Program	Aircraft Accident Investigation Team	X-ray
H Division Safety P.O.		MEDEVAC Coordinator		Hearing Conservation Program	Flight Deck Team	Physiotherapy
		Mail Courier		Communicable Disease Monitoring Program	SAR Response Team	Decontamination Team
		Communications Coordination		Non-Ionizing Radiation Personnel Exp. Survey	MEDEVAC Escort Team	Medical Response Team

Explanatory Notes
 3M - Material Maintenance Management
 PRP - Personnel Reliability Program
 PQS - Personnel Qualification Standardization

14-12

Figure 14-4. Functional diagram of medical department organization and services.

Facilities

Figure 14-5 shows a carrier profile and the location of the medical department aboard ship. On most carriers it is on the second deck, just below the hangar deck (main deck), between frames 90 and 120. Access is from the port or starboard side.

Figure 14-6 depicts the basic layout of a Nimitz-class medical department, showing the location of the various treatment and supporting spaces. Forrestal and Enterprise-class carriers have two wards with the advantage of using a specific area for sick call screening. Nimitz-class uses the physical examination area for sick call screening and schedules all physical examinations, eye, and ENT clinics after sick call is secured. The advantages of the Nimitz-class layout are size, privacy, and complete access control. Other notable features of the Nimitz-class carrier are the spacious surgical suite and the intensive care unit (ICU). The ICU has been retrofitted on Midway and Forrestal-class ships in recent years.

Figure 14-5 shows six dispersed and peripherally located aid stations on aircraft carriers called “battle dressing stations (BDS).” When the ship is in Readiness Condition I (general quarters), and all hands are at “battle stations,” the ship is entirely closed. All water-tight doors are secured in order to enhance the ship’s survivability. This can make casualty movement a tedious and difficult process. In order to avoid unnecessary delays in the primary treatment of injured personnel, the battle dressing stations are manned by physicians, dentists, and corpsmen so that casualties occurring within their areas of responsibility can be given primary emergency care until movement to the main sickbay can be effected.

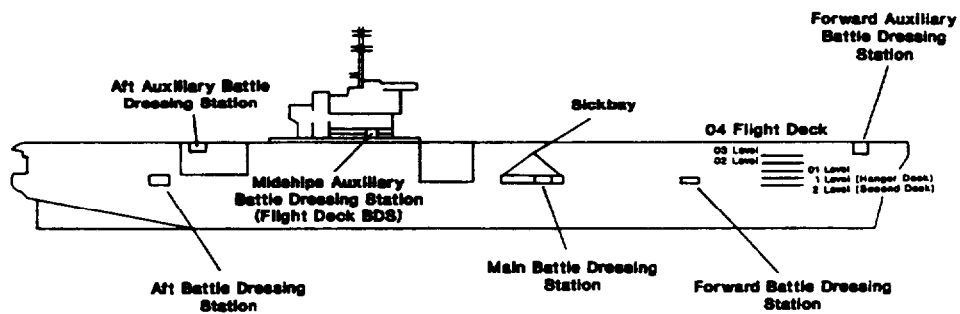

Figure 14-5. Location of medical spaces aboard an aircraft carrier.

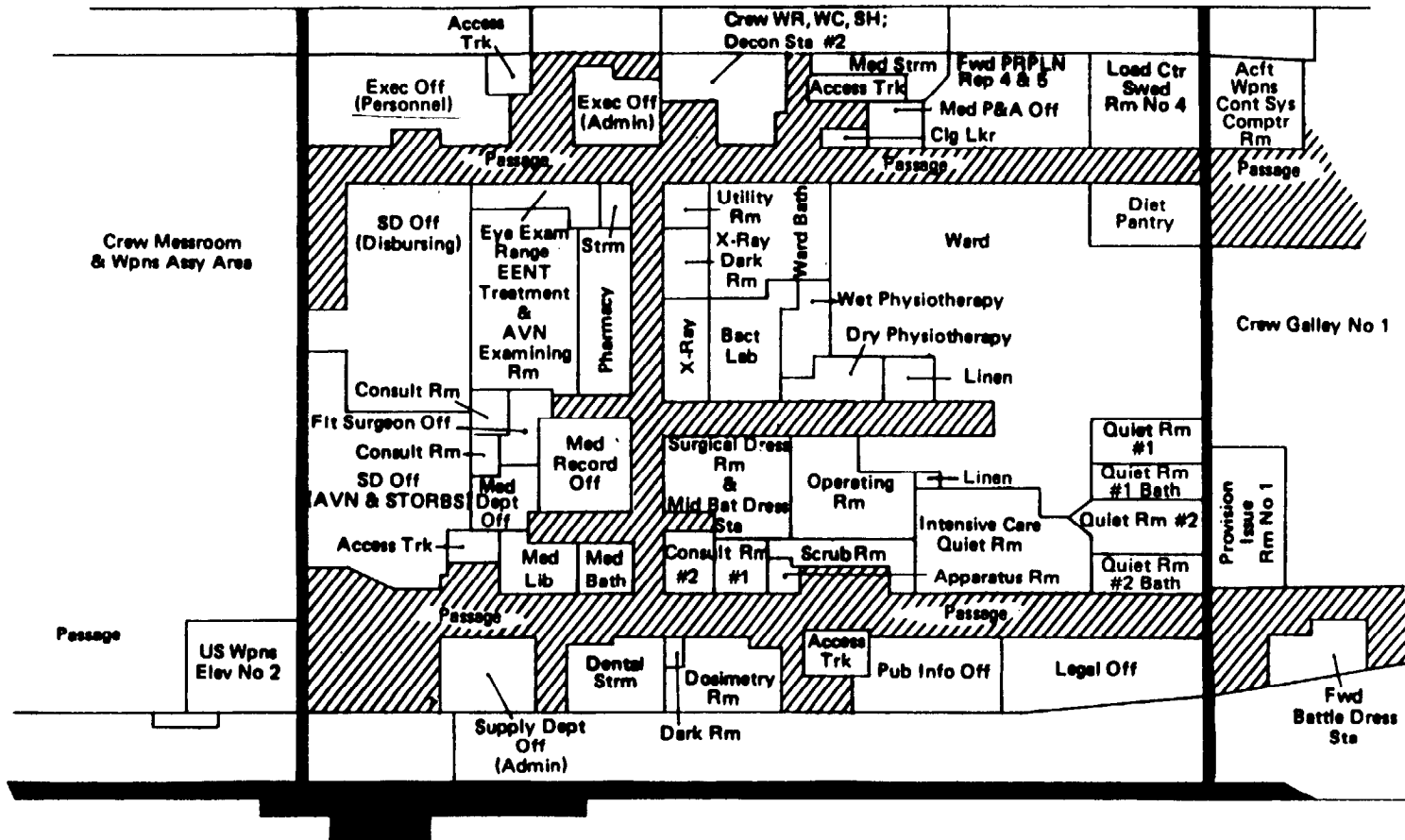

Figure 14-6. Medical department of a Nimitz-class carrier.

The Aircraft Carrier

A major advantage of the battle dressing station concept is that it allows the dispersion of medical personnel and equipment around the ship. Should one area of the ship be damaged with a loss of medical assets, there are still more available to carry on the job.

Mission and Capabilities of the Carrier Medical Department

The Carrier Environment. The intensity of carrier operations, with the 24-hour a day pace of launching and recovering aircraft while at the same time operating the carrier itself, combined with the ongoing need to feed and berth the crew, places heavy burdens on manpower and materials. Good hygiene and general cleanliness are hard to maintain and must be addressed constantly. Toxicological threats abound over the ship, and there are a thousand ways to be injured in the hazards of working areas. There are 2600 spaces on an aircraft carrier designed for general living, sleeping, eating, office work, maintenance and storage of equipment, heavy machinery, and computers. Much heat is produced that has to be dissipated or vented to the exterior; noise levels can be generated that must be isolated or protected against. Thousands of miles of cables, wiring, and piping provide power and services to all areas of the ship. Massive stores of several kinds of fuel, ordnance, and other combustibles are maintained. In effect, the functions of an industrial city with a military airfield are crammed into 32,525,000 cubic feet. In every area of operation in this floating city, the medical department has some interest and function. The medical department's mission in this changing and demanding environment is to support all functions of the ship by providing medical care to the sick and injured, to insure the health and well-being of the crew, and to provide relief and assistance to military and civilian personnel when required and as the commanding officer may direct.

Implementation of this mission is an endless and demanding task. The next sections describe the manner in which the functional requirements of this task are met.

Clinical Services. Direct patient care is the most obvious function of the medical department in the execution of its mission. Sick call is the initial point of entry into the health care function of the medical department. Next come the emergency room and the various outpatient clinics and services. Inpatient services include the ward, intensive care unit, and operating room functions. This is the "hospital" function of a carrier medical department and the one which requires constant attention to ensure the highest quality health care. Many nursing functions have to be assumed by corpsmen so an intensive training program is necessary to ensure that qualified personnel do this work. This is becoming increasingly difficult as more sophisticated equipment is being placed in a carrier medical department.

Table 14-4 depicts in summary fashion the patient care services and facilities available in a carrier medical department.

Table 14-4

Direct Patient Care

Facilities	Clinics and Services
Physical Exam Center	Sick call
EENT Room	Weight Control Clinic
Consultation Rooms (4)	Blood Pressure Clinic
Emergency Room	Eye Clinic
Surgical Suite	ENT Clinic/Audiometry
Ward	Minor Surgery Clinic
Isolation Rooms	Physiotherapy
Intensive Care Unit	Interview/Counseling Clinic
Wet and Dry Physiotherapy	Sexually Transmitted Disease Clinic
X-Ray	Physical Examinations
Laboratory	Inpatient Care
Pharmacy	(1) General Medical Care
	(2) General Surgical Care

Environmental Health and Preventive Medicine. With the advent of the Occupational Safety and Health Act of 1970, the preventive role in shipboard medicine has grown in visibility. Although a major concern aboard ship has always been the prevention of disease and injury, it is only recently that proper emphasis has been given to this topic. The traditional practice of shipboard medicine emphasizes the sanitation and hygiene aspects of a preventive medicine program. This includes potable water analysis, food service procedures monitoring, and sexually transmitted diseases and tuberculosis control.

Since 1970, hearing conservation and heat stress prevention have become quite important and are now operated as separate programs. Chapter 8, *Otorhinolaryngology*, describes the operation of a hearing conservation program. The need for baseline and reference audiometrics on all active duty military personnel is mandated, and careful follow-up must be maintained. This translates into approximately one audiogram for each man aboard ship per year (6000 audiograms for a Nimitz-class vessel). The logistics of this and audiometric booth certification are imposing. By direction, each of the audiograms must be a manually derived examination, so that up to 6000 manual audiograms, as well as the issuance of ear plugs and instructions, must be effected for a meaningful program.

The Aircraft Carrier

Heat stress has been a problem about naval vessels since the days of sail. Adequate ventilation and proper environmental temperature control have not been possible in even the best spaces until the past twenty years. Habitability, as an effective program, did not officially exist until the beginning of the 1970's. Like noise, controlling heat at its source always is the desired approach, but this usually takes expensive and time-consuming retrofitting. A monitoring program using the Wet Bulb Globe Temperature Index has been developed to identify and concentrate on areas of potential heat stress. Using these data and physiological limit tables, "stay times" for work can be devised to protect the watchstanders in these spaces. Heat stress is discussed in more detail in Chapter 20, *Thermal Stress and Injuries*.

A new area that is receiving systematic attention in preventive medicine is the hazardous materials monitoring program. A vessel of the size and complexity of an aircraft carrier has many operations requiring the use of known toxic or hazardous materials. The welding of zinc alloys, cleansing of boilers with toluol, entry into JP-5 tanks for cleaning, washing of aircraft with Turcot, use of halogenated hydrocarbons, asbestos lagging in all but the newest ships, and liquefied oxygen system maintenance are just a few of the many routine daily exposures to hazardous agents. The need for constant awareness, supervision, and training of personnel using these materials is obvious. Medical departments afloat must keep track of the chemical agents aboard, as well as the toxicology of these substances. Chapter 21, *Toxicology*, deals with this subject in greater depth.

Training Functions. A medical department has a training commitment to the ship and to itself. Damage Control Personnel Qualifications Standardization (PQS) requires a certain level of expertise in first aid on the part of all crewmen. This requires divisional training on a scheduled basis using corpsmen as instructors and unscheduled training of litter bearers and repair party personnel during general quarters drills. Shipwide training in the treatment of electric shock, the treatment of smoke inhalation, heat stress prevention, hearing conservation, and sight safety is now required by Type Commanders and is included in the fleet training group review of the adequacy of medical training programs. It is common for an aircraft carrier to schedule 300 man-hours of training on these topics per week, especially before an extended deployment.

There must be a comprehensive corpsman training program to ensure that competent and currently qualified personnel are manning the medical department. Qualifications have been established for 35 primary jobs and five secondary specialties. The jobs cover such diverse activities as sick call, lifeboat duty, rescue and assistance detail, repair party, audiogram technician, physiotherapy (including cast application), and intensive care unit nursing. The idea of this "PQS" program is to ensure that only qualified people perform specific tasks. To sustain such a program requires 10 hours of instruction per man per week. To ensure competency and continuity

in specific assignments, personnel should be rotated among the various work centers within the department. This rotation policy includes corpsmen with specialty NEC's. The diverse training a corpsman receives will benefit him and his future commands.

Casualty Management and Disaster Support. Aircraft carriers by their very nature present potential hazards to the personnel who operate them. In recent history, the USS *Enterprise*, USS *Forrestal*, and USS *Nimitz* have experienced major conflagrations involving upper decks. Since such events are possible, every aircraft carrier must have a workable and well-drilled mass casualty plan. This plan must address the physical layout of the ship, the closing of the ship during general quarters, the distribution of men and supplies, and the location of the accident or incident aboard ship. Concepts of triage and walking blood banks have to be understood by all. The plans must be flexible enough to withstand the loss of medical department spaces and personnel and to lend aid in the event of a disaster occurring on another vessel or ashore. In 1975, when the USS *Belknap* collided with the USS *Kennedy* both things happened. Main sickbay had to be evacuated while casualties from the USS *Belknap* were received for initial treatment and further evacuation.

Patient Transfer and Medical Evacuation. As a primary care facility, often supporting a population of 10,000 aboard and on ships in company, an aircraft carrier is frequently utilized as a receiving hospital and as a transferring facility for hospitals ashore. No two medical evacuations are the same. The basic principles are the same, however, and are discussed in Chapter 16, *Aeromedical Evacuation*. The evacuation of sick and injured personnel is an "art." Frequently, the physician is attempting to anticipate the occurrence of a pathophysiological event by several hours. If he waits too long, evacuation may be impossible. If he does not wait at all and evacuates the patient peremptorily, there may not have been a need to evacuate and the patient arrives ashore a well man. Judgment, caution, perception, and patience are mandatory. Often however, geographical location, time of day, weather, or ship's mission commitment makes the decision for the physician. When these factors operate, the situation may prevent evacuation, which explains the excellent medical facilities installed aboard carriers. Constant awareness of the ship's location, the weather, the ship's mission, and the aviation assets available for patient transfer are required to successfully coordinate a medical evacuation. When deployed overseas, it is imperative to know all of the details of the Air Force Medical Evacuation System, allied health care facilities ashore, and how to use them to the patient's best advantage. During the course of a normal cruise, such preparation and planning will be useful on more than one occasion.

The Cruise Cycle

It is hard to describe a "typical" cycle since the end of the Vietnam conflict. Basically, all ships go through such a cycle once every 18 to 24 months. A good starting point in describing the cycle

The Aircraft Carrier

is the yard period (either major overhaul or postcruise maintenance). The air wing disembarks after a cruise and returns to its various homeports to commence a standdown and then a retraining period. Figure 14-7 shows the schedule for the ship and air wing in parallel in a typical cycle. The at-sea periods vary after Advanced Training Assessment (ATA) before a cruise is scheduled, depending on whether or not there are fleet exercises or “minicruises” to be accomplished. Planning for personnel training, leave, supply acquisition, and specialty patient referrals is a constant problem during the cruise cycle, requiring much of the physician’s time and effort.

Shipboard Medicine

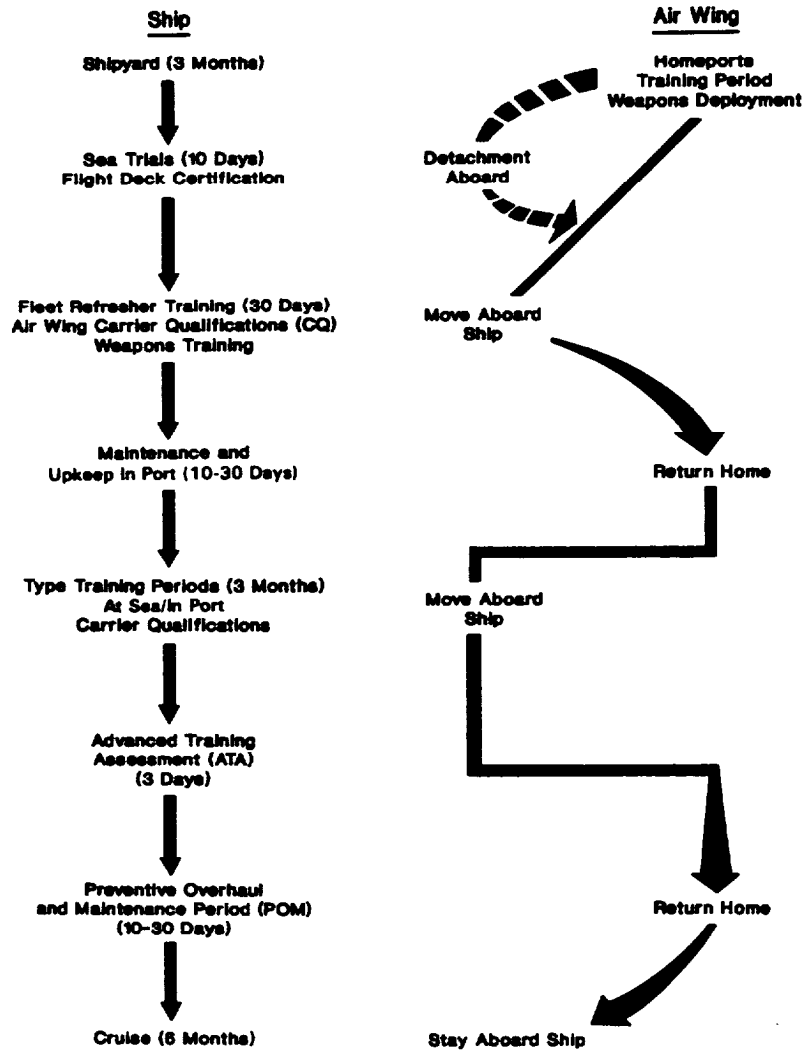

Figure 14-7. The ship/air wing cruise cycle.

The Air Wing Flight Surgeon

Duties and Responsibilities

The air wing flight surgeon is responsible for providing the air wing commander and squadron commanding officers with staff expertise on the physical and psychological aspects of aviation and for serving as a repository of information on physiological stress. Each air wing usually has billets for two flight surgeons. Air wing components are homeported at Cecil Field, Jacksonville, Florida (East Coast attack squadrons), Oceana Naval Air Station, Oceana, Virginia (East Coast fighter and heavy attack squadrons), Naval Air Station, Miramar, California (West Coast fighter squadrons), Naval Air Station, Lemoore, California (West Coast attack squadrons), and Naval Air Station, Whidbey Island, Washington (West Coast electronic warfare squadrons), as shown in Table 14-5. This represents a "base-loading" concept which places aircraft of a given type at a particular base for ease of training and maintenance.

Table 14-5

CV Carrier Air Wing

Aircraft	Squadrons	East Coast	West Coast
F-14 Tomcat	2	Oceana	Miramar
A-7 Corsair II	1	Cecil Field	Lemoore
A-6 Intruder	1	Oceana	Whidbey Island
EA-6 Prowler	1		Whidbey Island
E-2 Hawkeye	1	Norfolk	Lemoore
SH-3 Sea Knight	1	Jacksonville	North Island
S-3 Viking	1	Jacksonville	North Island
F/A- 18 Hornet	1	Cecil Field	Lemoore

A second responsibility for the air wing flight surgeon is to possess a working knowledge of the aircraft in which "his" aircrews fly in order to better assess the problems of the man-machine interface. This knowledge becomes vital both in reconstructing the event surrounding an aircraft incident or mishap and in preventing future similar occurrences.

A third responsibility is to serve as a physician in the naval medical care system. This is difficult sometimes since in his role as an air wing staff member a flight surgeon is not assigned to a specific medical facility. Wherever he goes, his medical function is as temporary additional duty.

The Aircraft Carrier

Aboard ship, he is part of the ship's medical department but still retains his responsibilities to the air wing commander. At home, he reports to the local clinic for additional duty but is required to spend productive time with the air wing staff as well. The flight surgeon utilizes the medical facilities to render care wherever he goes and has the additional requirement of maintaining close contact with his parent organization.

Assignments Ashore

The air wing flight surgeon is absorbed into the medical facilities at home port to assist in handling the increased work load his units place on the local health care system. This is usually at the air station branch clinic. While at home and between cruise cycles, the flight surgeon has much to do to prepare for the forthcoming cruise. Medical problems need follow-up, immunizations need updating, refresher survival and physiological training are required, training topics for squadrons need preparation, and the flight surgeon's own professional development requires attention.

Pre-cruise Preparation

As type-training nears completion, there are myriads of professional and personal details that require attention before the cruise commences. The ship is in port and the air wing returns home. Hearing tests, immunizations, physical examinations, and supply lists have to be completed in the remaining few weeks. Leave with the family is always desirable, but sometimes difficult to arrange. The list is endless and requires much attention. The ship leaves on schedule whether the individual is ready or not, so planning is a must. Most ships publish a deployment schedule to assist in planning milestones. Type Commanders also publish a check list for accomplishment prior to commencing an extended deployment (CNALINST 6000.1 series). Professionally, the cruise is much more rewarding if the air wing flight surgeon is organized and prepares for it carefully.

Assignments Aboard

When the air wing embarks, its flight surgeons report to the carrier medical officer for duty (temporary). It is common practice to rotate them in all an areas of health care delivery such as sick call, the physical examination center, EENT clinic, preventive medicine, and aviation medicine. This enhances the marriage of ship's company and air wing personnel into one functional unit. The corpsmen are similarly absorbed. Workload, watches, and stations during various emergency bills are shared equally. There is some free time for recreation and other time to attend to air wing matters. The work commenced at home intensifies aboard ship and continues unabated.

Summary

In the memory of most flight surgeons there resides a special place for their experiences aboard an aircraft carrier. Since World War II, the carrier has represented the epitome of what naval aviation is all about. Medically, it is unique among naval medical facilities and is becoming even more so with the newer carriers. The past 60 years has seen the development of the carrier medical department from a small "sickbay" to a medical and surgical hospital with more than 50 beds. It has its own medical and surgical intensive care facilities complete with volume respiratory support and monitoring equipment.

What makes a carrier unique in medical experience is its intense, demanding environment coupled with its mission. Routine operations are constantly highlighted by an aura of risk. The carrier's mission carries it to the forefront of national policy, especially in troubled areas. Its existence always implies the potential for danger and demands perfection, professionalism, and constant vigilance. Serving with a medical department aboard the largest warships afloat places a physician in the forefront of what is happening in the world, on his own, with no one else immediately available to assist him in making decisions or treating patients. The idea of causing a huge warship to deviate several hundred miles from its assigned mission in order to execute a rescue or to evacuate an individual ashore for definitive medical treatment is an awesome concept, but routine in the decision-making process regarding patient care aboard carriers.

The routine daily medical ministrations aboard a carrier bring a close association with the finest and most talented professionals in the world: the naval aviator, his aircrew, and all the personnel whose efforts allow man to fly from a ship at sea. To work with these people is a satisfying experience, and to fly with them, an incredible pleasure. To share the boredom of long at-sea periods, the sadness of family separation, the relief and joy of a liberty port, the gladness of a return home from a cruise - these are things that cannot be described nor appreciated by the uninitiated. All of this, together with practicing a rewarding subspecialty in medicine is what makes carrier medicine the satisfying experience and great challenge that it is.

CHAPTER 15

DISPOSITION OF PROBLEM CASES

Introduction

Section I: Medical Disposition

Introduction

Medical Disposition

Section II: Administrative Disposition

Introduction

Enlisted Administrative Separations

Section III: Aviation Disposition

Introduction

Identification of Problem Cases

Fitness for Duty

Local Board of Flight Surgeons

Special Board of Flight Surgeons

The Board of Flight Surgeons at the Bureau of Medicine and Surgery

Conclusion

INTRODUCTION

The etiology and resolution of people's *problems* are discussed in other sections of this manual: the subject of this chapter is the disposition of *people* whose problems are such that they may not be able to continue to serve effectively or safely. This discussion deals with questions such as (1) what to do with a military member who has developed a medical problem which might disqualify him or her from active duty, (2) how to help the command relieve itself of the burden of a person who cannot or will not function with sufficient maturity and responsibility to be an asset, and (3) how to clarify the classification of someone assigned to special duty when a question arises as to his or her continued qualification for such an assignment. Instructions from a variety of sources offer guidance in these considerations: the flight surgeon should have, readily available, at least those listed in Table 16-1.

Other references should be in a file maintained by the administrative officer in the hospital, clinic, or ship's medical department. Recommendations prepared for action by higher authority

U.S. Naval Flight Surgeon's Manual

will achieve an added measure of credibility if all provisions of the applicable instruction are addressed and if the instruction is then specifically cited. For example, the sentence concluding the report of a flight surgeon's evaluation recommending the administrative separation of a member because of sleepwalking might be: "It is recommended that (name) be administratively separated from the naval service by reason of Convenience of the Government (somnambulism) in accordance with the provisions of MILPERSMAN 3620200."

As a final introductory comment, it should be noted that these instructions are changed from time to time. The flight surgeon and his or her administrative staff must ensure that the series of instructions they hold is current.

Table 15-1

Instructions for Medical Administrative Disposition

<i>Manual of the Medical Department</i> ,	General Instructions, Physical Standards
NAVMEDCOM Instructions	1300.1 Suitability Processing for Overseas Assignment of Members and Dependents
	1910.2 Members Not Fit for Shipboard Duty
	5300.2 Rehabilitated Alcoholic Aircrew Members and Air Traffic Controllers
	5355.1 Drug Abuse Prevention and Control Program
	6110.3 Support for Health and Physical Readiness Program
	6520.1 Management of Patients with Suicidal Ideation or Behavior
BUMED Instruction	6120.20 Competence for Duty Examinations
OPNAV Instructions	5350.4 Alcohol and Drug Abuse Prevention and Control
	6110.1 Physical Readiness Program

Disposition of Problem Cases

International Classification of Diseases, World Health Organization, current edition.

Diagnostic and Statistical Manual, American Psychiatric Association, current edition.

SECTION I: MEDICAL DISPOSITION

Introduction

In the event of a medical problem which might degrade a member's fitness to continue active service, the question of disposition must be addressed. This is typically done by convening a Medical Board. Medical Boards afford an opportunity for formal discussion and evaluation of a patient's case; review of his or her clinical, health, and other appropriate records; and formulation of a carefully considered recommendation to higher authority as to the member's fitness for continued service. Medical Boards should be convened in the following circumstances:

1. A physical defect is likely to preclude further military service.
2. Further military service is likely to aggravate an existing problem.
3. An inordinate amount of hospitalization or close medical supervision is anticipated.
4. A member's condition is temporarily incompatible with unrestricted duty, but full recovery is anticipated.
5. The ultimate restoration of function is uncertain, and there is a desire to follow the patient for a period of time.
6. A member's condition is such as to require geographic or other limitations of assignments.
7. There is a question of mental competence.
8. A patient refuses indicated treatment.
9. There is a need to document formally a condition which is likely to recur. As an example, consider the case of a man or woman who developed depression or arthritis while on active duty but, with treatment, the condition improved such that the member was asymp-

tomatic without treatment at the time of retirement or release from active duty; a Medical Board prepared at that time could be used by him or her in the event of a later recurrence to document the service-connected origin of the problem.

Medical Disposition

The ensuing discussion of medical disposition is reproduced, essentially unchanged, from the most recent (1978) edition of the *U.S. Naval Flight Surgeon's Manual*. As this revision is being prepared, medical disposition procedures are being reviewed and we anticipate a substantially simplified and streamlined protocol by late 1990. Before proceeding on the basis of what is printed here, you should ensure that governing directives have not already been revised. As soon as the expected changes are issued, replacement pages for this text will be prepared and distributed.

Composition of a Medical Board

A Medical Board normally is composed of two medical officers--the doctor who took care of the patient and that doctor's immediate superior; a third member may be appointed when appropriate. A dental officer should be a member of the board when the patient's condition relates to a dental problem. When the patient is a reservist, one member of the board should be also. When there is a question of mental competence, there must be three members of the board, and one must be a psychiatrist. A flight surgeon should be a member of all boards on naval aviators and naval flight officers who are returned to full duty or limited duty.

Convening Authority for Medical Boards

Medical Boards may be convened by the commanding officers of all naval hospitals, the Naval Medical Clinic, Pearl Harbor, or higher authority. The Convening Authority prepares an endorsement for each Medical Board before forwarding it to higher authority and, in many cases, is authorized to act on the recommendation of the Medical Board without waning for Bureau review, thus avoiding costly delay. There is no longer a requirement that patients be admitted to a hospital for a Medical Board. Outpatient Medical Boards are often more convenient and more expeditious. They require only that the patient be assigned to the command of the Convening Authority on the day the board is held (easily accomplished by no-cost TAD orders). The opinions and recommendations of specialty consultations can be incorporated as enclosures to such boards.

Medical Board Report

The report of the Medical Board, to be submitted via the Convening Authority, should present in narrative form, all pertinent data concerning each complaint, symptom, disease, injury, or disability presented by the member which causes or is alleged to cause impairment of function. The narrative must be clear, concise, and sufficiently comprehensive to enable a reviewer who cannot see the patient to render an appropriate decision regarding the recommended disposition. Above all, the member's current physical status must be clearly reflected. The report consists of three main parts: an introduction, a narrative account, and recommendations.

The introductory section should contain such information as the patient's age, marital status, rate or rank, years of service, nature and duration of symptoms which led to the evaluation, and the initial diagnosis.

The narrative section should be no more, and certainly no less, than the narrative summary prepared after all hospitalizations and periods of outpatient treatment. A review of the problem, a pertinent background history, and appropriate physical, mental, and laboratory examination data are essential. The narrative should include all positive and all pertinent negative findings at the time of the initial evaluation, the treatment and procedures instituted, and the patient's general progress under this regimen.

All Medical Board reports should conclude with a section presenting the member's current physical status, the anticipated future course of his or her condition, and the board's opinion as to the most appropriate disposition. There are only four recommendations which a Medical Board 'may make:

1. *Fit for Full Duty.* The member is considered fully qualified for all duties appropriate to his or her rate or rank, without physical or geographic restrictions. It should be clear that it is only with a recommendation for return to full duty that a determination of an individual's flight status can be made. A person not fit for full duty is not qualified for special duty, such as aviation. Furthermore, aviation personnel cannot be returned to any flight status by Medical Board action; this requires a separate determination which will be discussed in the section on aviation disposition.
2. *Fit for Limited Duty.* The member is considered fit for duty, but this must be restricted commensurate with his or her condition. A limited duty status is arbitrarily restricted in time to six months and, geographically, to CONUS: additional qualifications may be recommended as appropriate (e.g., after laminectomy, a member might be restricted from

lifting and long periods of standing; a member recovering from a depressive episode might be retained in an area where outpatient psychotherapy is available). Within six months following a Medical Board recommending limited duty, another board must be convened which can make any of these four recommendations, including another period of limited duty. Normally, no more than three such six-month periods will be approved. If a person is not fit for full duty by that time, it is usually most appropriate to refer his or her case to the Physical Evaluation Board.

3. *Administrative Processing.* The patient's case is most appropriately handled through administrative rather than medical channels. Occasions for this recommendation arise, for example, when a person must be hospitalized for treatment of a disqualifying condition which he or she fraudulently denied having had at the time of enlistment, or when a person who cannot adapt to military service because of a personality disorder is hospitalized because of a manipulative suicide gesture. Attention is invited to Section II, Administrative Disposition.
4. *Referral to the Physical Evaluation Board.* The member is physically or mentally unfit for continued military service and should be medically separated. This recommendation and many of its ramifications will be discussed below.

Whenever a Medical Board is contemplated, a Disability Evaluation System Counselor (DESC) is appointed to ensure that the patient understands his or her rights. The patient will, unless there is felt to be a contraindication to this in regard to his or her physical or mental health, be invited to meet with the members of the board to discuss their findings and recommendations. If he or she is satisfied with these, the member must sign a statement to that effect; if he or she wishes to rebut any of these, five working days will be allowed to prepare a formal exposition of the objections. In the latter case, board members have the option of preparing a surrebuttal statement. After endorsement by the Convening Authority, the report is sent for a higher review.

Necessity for Accurate Medical Board Reporting

Information contained in Medical Board reports may play an important role in determining a person's eligibility for a variety of benefits, as well as in the immediate disposition of the case. It is important, therefore, to include in the report all available information, with adequate documentation, concerning the origin, nature, conduct status, and aggravation by service of any condition discussed. Wherever possible, impairment of function should be reported in terms of objective tests or findings rather than as opinion or conjecture. Where no impairment exists, this should be stated. Where an impairment involves an upper extremity, left or right "handedness"

Disposition of Problem Cases

should be specified. Sufficient information for proper assessment of overall disability or functional impairment must be presented. In cases referred to the Physical Evaluation Board, the report must contain information on all rateable conditions, even if some do not represent functional impairment or lead to unfitness in and of themselves.

Medical Disability

When a Medical Board and its Convening Authority recommend that a patient be considered unfit for continued service, the member's case is referred to the Central Physical Evaluation Board (CPEB). The CPEB consists of one medical officer and two line officers. When the patient is a member of minority group or a reservist, at least one of the members of the CPEB will be also, insofar as is practical. The CPEB, solely on the basis of the Medical Board Report, will render an opinion as to the patient's fitness for duty. If the determination is that he or she is not fit for continued service, the CPEB will then rate the disability with a percentage figure which the members believe reflects accurately the extent of impairment the condition would constitute in the civilian job market. Establishing disability ratings is the prerogative of the CPEB and not of the Medical Board which referred the case. The role of the Medical Board is to describe and document the impairment with sufficient clarity and accuracy to enable an appropriate CPEB determination. It is especially important that conjecture regarding disability ratings by members of the Medical Board to the patient or his or her family be avoided.

The CPEB's recommendation is returned to the patient. If he or she chooses to accept it, the paperwork is passed to the Physical Review Council and the Judge Advocate General's office for review before approval by the Secretary of the Navy. Should the patient be dissatisfied with the CPEB's recommendation, he or she has the right to appeal to a Formal Physical Evaluation Board (FPEB). The patient may choose to appear in person before an FPEB or to request instead only that an FPEB review the documents relevant to the case (a full and fair, or a prima facie hearing, respectively). Regardless, the member may present testimony from other military medical consultants or be represented by military attorneys at no cost, or he or she may retain civilian consultants and civilian attorneys at his or her own expense. The recommendation of the FPEB is passed to the Physical Review Council, whose recommendation is then returned to the patient. If he or she remains dissatisfied, appeal is again possible, either with a full and fair or prima facie hearing, before the Physical Disability Review Board. The recommendation of this Board, after review by the Judge Advocate General's office, is then passed to the office of the Secretary of the Navy for a decision. The patient has no formal appeal mechanism at this point, but every effort will have been made to ensure fair and impartial treatment.

If the outcome is that the member is not fit for duty and that the disability rating is less than 10

percent, a separation will ensue which will terminate the member's relationship with the military without compensation (unless entitlement to retirement benefits has been earned by longevity).

If it is determined that the patient is not fit for continued service and that the disability rating is more than 10 percent and less than 30 percent, he or she will be separated with a lump sum severance payment, the amount of which is determined by the member's longevity, rate or rank, and the actual percentage of disability established. This terminates the member's relationship with the military; no other benefits will be accorded unless the member had already served on active duty for a sufficient period to have established eligibility for retirement.

If the patient is found unfit for duty, and the disability rating is at least 30 percent, he or she normally will be placed on the Temporary Disability Retired List (TDRL) for a period not to exceed five years. While on the TDRL, the member's case will be reviewed every 18 months at a military medical facility. The report of this review is essentially another Medical Board, and it should document clearly the difficulties and successes he or she has experienced in adapting to civilian life. The disability rating may or may not change as a result of these TDRL evaluations. At any time while on the TDRL, it may be determined that a patient's condition has improved to the point that he or she is once again fit for duty. The member then would be invited to return to active duty; the years on the TDRL would be credited toward longevity but not toward promotion or retirement eligibility. Should the member choose not to return to active duty, the disability compensation and all other benefits would cease and he or she would be separated. After five years on the TDRL, most patients are moved to the Permanent Disability Retired List (PDRL). There is no necessity, however, for maintaining a patient on the TDRL for the full five-year period. He or she can be transferred to the PDRL at any time it becomes clear that there is no reasonable likelihood of being restored to an active duty status.

Whether on the TDRL or the PDRL, a person receives medical disability compensation payments. These are established by multiplying the current monthly base pay for the rate or rank the member had achieved when medically retired by the percentage of disability established, with the latter limited to 75 percent; the maximum a person could receive in retirement pay after 30 years of service. For example, an O-5 with 16 years active duty who incurred a disability rated at 50 percent would receive 50 percent of the base pay for an O-5 with 16 years service. Had the disability been rated at 100 percent, he or she would receive 75 percent of the same base pay. Any person on the TDRL or PDRL becomes a Veterans Administration Beneficiary (VAB). In the situation where disability payments, computed as described would be less than those derived from a VA table which considers only percentage disability and not rank or years of service, the member is invited to waive payments from the military in order to receive the higher payments from the VA. This would be the case with many enlisted members and some junior officers with

Disposition of Problem Cases

few years of active duty. In either case; medically retired members retain essentially the same rights to the use of base facilities (commissaries, exchanges, etc.) and to military and CHAMPUS-sponsored medical care as are enjoyed by members who retire on longevity.

All disability compensation for members continuously on active duty since before 25 September 1975 is exempted from Internal Revenue Service taxation. For those whose active service commenced after that date, disability must have been incurred in combat-related circumstances in order to qualify for the income tax exemption. As an example, if a member reports a physical disability at the time of examination for retirement after 30 years of service and is awarded a 50 percent disability for this, he or she would receive 75 percent of the base pay of longevity, and two-thirds of this amount (50 percent of the base pay) would be exempted from Federal taxation. Because of alleged abuse, PEB action in the case of senior line officers and all medical officers is reviewed by a Congressional panel.

General Comments

What has been discussed is the disposition of active duty personnel who develop an illness or sustain an injury which renders them unable to continue to function effectively. They are assured that if their ability to provide for themselves in civilian life should become compromised, they will be compensated. On the other hand, the military assumes no responsibility for inherent defects in character development which may cause an individual to be unable to function effectively, with the maturity inherently required, in a military organization. Those who cannot accept the responsibility of military service are dealt with administratively, rather than medically, and their deficiencies are not compensated.

Questions of good and bad might occur at this point. It should be understood clearly that whether or not a situation constitutes a problem for a member or for society is one issue: the determination of whether the same condition might compromise his or her effectiveness in military service might be entirely contrary. For example, people with certain personality disorders, people who choose to use drugs "recreationally," people whose sexual preference is --while not conventional -- not disruptive to society when conducted by mutual consent in privacy, and people who genuinely develop an irreconcilable conviction that war is wrong, might all make very positive contributions to society. Under conditions as they now prevail, however, none of these people can function effectively in military service. For that reason, an avenue to provide for their discharge by administrative means has been established. Our referring to their conditions as "defects" is not meant to connote a value judgement but rather to differentiate their reasons for being unable to serve from those compensable reasons which are related to diseases and injuries.

SECTION II: ADMINISTRATIVE DISPOSITION

Introduction

Most of the problems to be addressed in this section, with the exception of alcoholism, homosexuality, and conscientious objection to military service, are encountered most often in enlisted personnel. This is a reflection of the selection criteria imposed on officer candidates. Almost all officer procurement programs require either an extended period of exemplary enlisted service or selection through a competitive process which requires at least the attainment of an undergraduate degree, either of which tends to eliminate people who would have many of the kinds of difficulties to be discussed.

Most of the instructions which will be outlined apply specifically to enlisted personnel; the administrative disposition of officers with problems comparable to those discussed for enlisted personnel is specified in MILPERSMAN 3410100, summarized below (For Marine Corps officers, see Chapter 4 of the Marine Corps Separation Manual). Among other subjects, in this Article you will find addressed the disposition of, and reporting requirements for, officers in an unauthorized or unexplained absence status; those who have discredited the Navy through debt, nonsupport of dependents, and paternity; and those who have been brought to nonjudicial punishment (NJP) or action by a civil court or a military court-martial. Disposition of officers suspected of homosexual involvement (see SECNAVINST 1920.6) is discussed in this article.

Of particular concern to the flight surgeon is MILPERSMAN 3410100.7E(6) which requires, when neither a psychiatrist nor a clinical psychologist is reasonably available, that a flight surgeon or other medical officer evaluate members being processed for homosexuality and determine whether there is a psychosis or other mental disorder for which the member should be processed through Medical Board action; whether the member is competent and able to understand the implications of submitting a resignation or being the subject of court-martial proceedings; whether, in the case of a neurotic disorder or other psychiatric condition, the member can control his or her behavior and whether physical restraint is necessary for the protection of the member or anyone else; and whether the officer being interviewed might be feigning homosexuality to obtain separation or to avoid undesired duty. Elsewhere in this Article, for such problems as misconduct, negligence, incompetence, disregard, and unsatisfactory or marginal performance, "detachment for cause" of officers is discussed, along with the additional requirements which apply in the case of detachment for cause of incumbent and prospective commanding officers and officers in charge. Throughout this Article are reaffirmations of the need for correct, comprehensive, and credible documentation in all administrative processing; also emphasized is the assurance provided in Navy Regulations of every member's right to respond formally to any information which

Disposition of Problem Cases

might be construed as adverse *before* such information is made a part of that member's official record.

Enlisted Administrative Separations

Chapter 36 of the *Naval Military Personnel Manual* (MILPERSMAN) provides overall policy and procedural guidance pertaining to all enlisted administrative separations. We have organized the following brief summary of the major issues around the relevant MILPERSMAN articles, in consecutive order; Articles of Chapter 36 which are likely to be of no interest to most flight surgeons are indicated by an asterisk (*) and are not summarized here. When there is known to be a closely corresponding *Marine Corps Separation Manual* (MARCORPSEPMAN) paragraph, this is indicated in parentheses; when no such notation appears, we recommend the flight surgeon serving with Marine Corps units refer to the Table of Contents for Chapter 6, MARCORPSEPMAN for guidance.

MILPERSMAN 3610100 Enlisted Administrative Separations

This Article provides an overview of the process and a statement of the philosophy involved. The discussion begins with a listing of the formal *reasons* for administrative separation:

1. Selected Changes in Service Obligation.
2. Expiration of Enlistment, Fulfillment of Service Obligation, Expiration of Tour of Active Service.
3. Convenience of the Government:
 - a. Dependency or hardship.
 - b. Pregnancy or childbirth.
 - c. Parenthood.
 - d. Conscientious objection.
 - e. Surviving family member.
 - f. Other designated physical or mental conditions (somnambulism, enuresis, personality disorders, motion sickness, allergies, excessive height, and obesity).

U.S. Naval Flight Surgeon's Manual

- g. Alien
- 4. Disability.
- 5. Defective Enlistment or Induction (erroneous, defective, minority, or fraudulent).
- 6. Entry Level Performance and Conduct.
- 7. Unsatisfactory Performance.
- 8. Homosexuality.
- 9. Drug Abuse Rehabilitation Failure.
- 10. Alcohol Abuse Rehabilitation Failure.
- 11. Misconduct:
 - a. Minor disciplinary infractions.
 - b. Pattern of misconduct.
 - c. Commission of a serious offense.
 - d. Civilian conviction.
- 12. Misconduct -- Drug Abuse.
- 13. In Lieu of Trial by Court-Martial.
- 14. Security.
- 15. Unsatisfactory Participation in the Ready Reserve.
- 16. In the Best Interest of the Service.

Note that many of the formal reasons listed for separation in no way imply anything negative about the member. Indeed, by far the most common reason for administrative separation of

Disposition of Problem Cases

enlisted members is discharge by reason of expiration of enlistment or release to inactive duty upon completion of active obligated service. In most cases, members separated for those reasons have served effectively for the period of time for which they volunteered and now wish to exercise their prerogative of continuing their education or pursuing a different career field. On the other hand, members separated for reasons cited later in the list will have demonstrated an inability to adapt to military service and will have become a burden, instead of an asset, to their command.

Individuals who lack the ability or the desire to become good sailors should be separated. Commands must, however, devote a sincere effort to the development of those marginal members who give indication of potential for maturing into useful sailors or marines. If it becomes evident during that effort that the member is not going to adjust, continued retention and further counseling would constitute a pointless drain on resources. The timely and carefully considered use of administrative separation procedures can ensure staffing by individuals who will meet the standards of duty, performance, and discipline needed to accomplish the mission. The loss of training and equipment costs and related expenses, and the cost of recruiting and preparing a replacement for the member separated prior to completion of his or her obligated service should not be overlooked. But when a person's nonconformance with our standards of conduct, discipline, and performance creates a high cost in terms of wasted pay, recurring administrative actions, deterioration of others' morale, and compromise of mission readiness, the need for prompt administrative separation will be apparent.

When the command decides to proceed with administrative processing for separation, strict compliance with all provisions of the relevant MILPERSMAN Article(s) is mandatory. Less than this will invite processing delays, disapproved recommendation, violation of members' rights, and litigation.

MILPERSMAN 3610200 (6002) Definitions and Guidance Concerning Separation of Enlisted Personnel

This Article begins with a lengthy list of definitions of commonly used terms. A few of these are paraphrased here:

Administrative Board. An Administrative Board is required in the processing of separations of individuals who will not or cannot conform to acceptable standards of conduct, discipline, and performance, and who create high costs in terms of pay, administrative effort, degradation of morale, and substandard mission performance. It reviews the case and recommends disposition (retention, separation, or suspension of separation), assigned reason for separation, and characterization of service or description of separation.

U.S. Naval Flight Surgeon's Manual

Separation. Separation is a general term which includes discharge, release from active duty, transfer to the Fleet Reserve or Retired List, release from custody and control of the military services, transfer to the Individual Ready Reserve (IRR), and similar changes in active or reserve status.

Administrative Separation. Administrative Separation is a discharge or release from active duty at or prior to the expiration of an enlistment or required period of service -- except any separation effected by sentence of a general or special court martial.

Release from Active Duty. Release from Active Duty is the termination of active duty status and transfer or reversion to a Reserve component not on active duty, including transfer to the IRR.

Discharge. Discharge is the complete severance from all Naval status gained by the enlistment or induction concerned.

This Article continues by noting that several of the reasons for processing members for administrative separation are so inconsistent with appropriate standards of conduct and performance that such processing is mandatory: commission of a felonious offense, commission of a serious offense which reflects sexual perversion, homosexuality, sale or trafficking of drugs, or possession of drugs in amounts exceeding those reasonably considered to be for personal use.

Pursuing a theme introduced in the preceding Article, there is an admonition (unless processing for separation is mandatory) to consider the member's potential for maturation or rehabilitation which might make useful naval service possible in the future. Several factors are specifically recommended for consideration in developing the bottom-line recommendation for retention or separation. In appropriate circumstances, recommendation of suspension of separation is encouraged. With this, the separation is approved but not carried out for a specified period, not to exceed one year. The member will be retained unless carefully detailed circumstances recur; he or she will be counseled and will understand clearly that the suspension will be vacated and the separation effected promptly in the event of further problems. For many members, the inducement to mature is strong because, if no problems occur during the period specified, the formerly approved separation is rendered inoperative and the individual is free to continue his or her career.

Finally, this Article assures enlisted members a variety of protections. One is that a member who is retirement-eligible and being processed for administrative separation will be allowed to transfer to the Fleet Reserve or the Retired List. In these cases, if there is a determination of un-

Disposition of Problem Cases

satisfactory performance in the current pay grade, the member may be reduced to the next inferior pay grade prior to transfer. Another of the protections assured is that members of Reserve components, on active duty and within two years of becoming eligible for that pay will not be separated involuntarily unless the Secretary of the Navy specifically approves the separation.

MILPERSMAN 3610300 (6107) Types of Characterization of Service and Descriptions of Separation and Guidance for Assignment.

Confusion sometimes arises between the formal reasons for administrative separation and the types of characterization of service or description of separation. All separations fall into one of the following three categories: *administrative separations with characterized service* (Honorable, General, and Under Other than Honorable Conditions), *judicially conferred separations with characterized service* (Bad Conduct Discharge and Dishonorable Discharge), and *administrative separations with uncharacterized service* (Entry Level Separation and Order of Release from the Custody and Control of the Armed Forces).

Honorable. The honorable characterization is appropriate when the quality of the member's service has for the most part consisted of "proper military behavior with proficient and industrious performance of duty." Operationally, for Navy personnel, this is defined as having been awarded enlisted performance evaluations (quarterly marks) with a final average in performance and conduct grades of not less than 2.8 and an average of not less than 3.0 in personal behavior. For Marine Corps personnel, there is a different but corresponding threshold of average grades.

General. The General characterization is under Honorable Conditions and will be assigned "when service has been honest and faithful but significant negative aspects of the member's conduct or performance of duty outweigh positive aspects of the member's service record." With some specified exceptions, a separation will be characterized as General if the final average (for Navy personnel) of performance and conduct grades on quarterly marks for the period of service falls below 2.8 or a trait average for personal behavior is less than 3.0. Again, there is an equivalent threshold for Marine Corps members.

Other Than Honorable. Characterization of service as Other Than Honorable is appropriate when the reason for separation is based upon either a pattern of adverse behavior or one or more acts or omissions that constitute a significant departure from the conduct expected of members of the naval service. Examples of behavior which might lead to characterization of service as Other Than Honorable are causing serious injury of another person, endangering the security of the United States, drug abuse, civil felony convictions, and some instances of homosexual behavior.

Bad Conduct Discharge. Bad Conduct Discharge is under Other Than Honorable Conditions and may result only from the approved sentence of a Special or General Court-Martial.

Dishonorable Discharge. A Dishonorable Discharge is under Dishonorable Conditions and may result only from the approved sentence of a General Court-Martial.

Entry Level Separation. In an Entry Level Separation, the service is uncharacterized. This is usually most appropriate when the separation occurs during the first 180 days of service, before there has been an adequate opportunity for the realistic performance assessment needed to characterize service, as above. However, this Article does list a variety of circumstances under which a characterized administrative separation can be conferred during the first 180 days.

Order of Release from the Custody and Control of the Armed Forces. An Order of Release from the Custody and Control of the Armed Forces may be issued to void an enlistment or induction. Examples of situations wherein this might be appropriate include enlistments effected without the voluntary consent of a person who has the capacity to understand his or her action (e.g., the member was either insane or intoxicated when enlisted, or was coerced into enlisting by being presented this as an alternative to imprisonment by a civil court), enlistment of a person less than 17 years of age, and enlistment of deserters from military services.

MILPERSMAN 3610320 (General Provisions Relating to Enlisted Separations)

MILPERSMAN 3620100 (6202) Separation of Enlisted Personnel by Reason of Selected Changes in Service Obligation

This Article summarizes procedures to be followed to change members' service obligation so as to effect separation earlier than the original expiration of active obligated service. Characterization of service at separation will be Honorable, unless provisions of another Article require a different characterization. Some of the reasons for which service obligations can be changed are:

1. To comply with orders for a general demobilization, reduction in authorized strength, or a reduction of staffing levels in a specified class of personnel.
2. To enable a member to accept an active duty commission or to enter a program (e.g., OCS) leading to a commission.
3. To enable a member to accept immediate enlistment or reenlistment.

Disposition of Problem Cases

4. To accommodate the request of a member who has been appointed or ordained a minister of religion or who wishes to take the final vows of a religious order.

5. To accommodate, under specified circumstances, Naval Reservists' requests for interservice transfer to other Reserve components of the Armed Forces.

6. To avoid problems introduced by either the deployment or the change of homeport of the member's command immediately prior to his or her release date.

7. To avoid pointless retention of personnel who have nearly completed their service obligation, who do not wish to reenlist, and who either have arrived early at a separation activity or have been found fit to resume full duty after a period of temporary duty under treatment.

8. To enable separation on the workday preceding the weekend or holiday on which the service obligation expires, prior to rather than during the Christmas-New Year's holiday period, or immediately after an extended deployment if the service obligation expires within 30 days, or if the member extended his or her obligation for the express purpose of participating in or completing that deployment.

MILPERSMAN 3620150 (1005) Separation of Enlisted Personnel by Reason of Expiration of Enlistment, Fulfillment of Service Obligation, or Expiration of Tour of Active Service.

This article provides administrative guidance for effecting the separation of the majority of enlisted personnel -- those men and women who have served on active duty for the period of time for which they undertook an obligation and who now wish either to continue their formal education or to pursue a nonmilitary career field. The difference among the three categories listed in the title might not be clear. The first applies to discharge when the member has no additional service obligation (active or reserve) after having served until the normal date of expiration of enlistment, extension of enlistment, or period of induction. In the second type of discharge, "Fulfillment of Service Obligation" is the formal reason for separation (when no additional active or reserve obligation remains) which would conclude a period of service to which the member had been ordered by a reactivation of the draft under the Military Selective Service Act. "Expiration of Tour of Active Service" is the formal reason for separation when, at the completion of the required period of active duty, the member is released to inactive duty in the Naval Reserve to complete his or her service obligation; note that this last reason for separation is not a discharge, so no certificate characterizing service is issued at the time of separation. For the first two reasons for separations, both constituting a discharge, characterization of service will be Honorable unless provisions of another Article (e.g., MILPERSMAN 3610300) require a different characterization.

MILPERSMAN 3620200 (6203) Separation of Enlisted Personnel for Convenience of the Government

This is the first, and probably the most often used, of several Articles which authorize the separation of enlisted members prior to the expiration of their enlistment or obligated service for a variety of reasons subsumed under the category of "Convenience of the Government." If discharged for this reason, the characterization of service will be Honorable unless another Article requires a different characterization. All outstanding disciplinary actions involving the member must have been resolved before separation may be effected under this Article.

Dependency or Hardship and Pregnancy or Childbirth. Dependency or hardship and pregnancy or childbirth separations are addressed in the summaries of MILPERSMAN 3620210 and 36230220, respectively, which follow the present discussion of MILPERSMAN 3620200.

Parenthood. Parenthood which causes a member to be unable to perform duties assigned, to be absent repetitively, or to be unavailable for worldwide assignment or deployment may lead the Commander, Naval Military Personnel Command (NMPC-243) to direct separation (under MILPERSMAN 3630300). Formal counseling (as described in paragraph 4 of this Article) and an opportunity to overcome the deficiencies is required before processing may be undertaken. This Article requires documentation of specific aspects of the individual situation and, in the case of involuntary separations, implementation of the Notification Procedure (MILPERSMAN 3640200).

Conscientious Objection. Conscientious Objection to military service is defined as a firm, fixed, and sincere objection -- based on religious training and belief - either to participation of any kind in war in any form (Class 1-0) or to participation as a combatant in war in any form (Class 1-A-0); the convictions of Class 1-A-0 members will permit military service in a noncombatant status. Designation as a Class 1-0 Conscientious Objector is another of the conditions for which separation by reason of Convenience of the Government may be authorized. Specific procedures for processing both officers and enlisted members appear in MILPERSMAN 1860120 and will not be summarized here. Of primary concern to the flight surgeon is the requirement that each applicant for Conscientious Objector designation be interviewed by a psychiatrist or clinical psychologist; when neither of these is reasonably available, the report of a psychiatric evaluation by a nonpsychiatrist medical officer may be submitted. The interview should consist of a comprehensive psychiatric evaluation, and the report should credibly establish either the absence or the presence of psychiatric disorders which warrant action through medical disposition channels, or personality disorders or other conditions which would justify alternative administrative disposition. Assuming that neither a psychiatric disorder nor a personality disorder or other con-

Disposition of Problem Cases

dition is present, the examining physician or psychologist is invited to comment about the sincerity of the applicant's claimed convictions.

Surviving Family Member. These situations are summarized in the discussions of MILPERSMAN 362024.0 and 3620245, which follow.

Other Designated Physical or Mental Conditions. Inherent or developmental defects that do not constitute a physical disability, may lead to a member's administrative separation under the provisions of this Article. In most cases, processing for separation is appropriate only if the condition interferes with the member's performance of duty or poses a threat to his or her safety or well-being and renders the individual incompatible with further naval service. A Medical Board is seldom needed; however, a physician's statement is often very valuable in clarifying the situation and ensuring appropriate disposition. The following is a list of conditions which can form the basis for administrative separation under this paragraph, along with the minimum documentation which must be submitted with each request:

1. *Somnambulism.* Somnambulism requires sworn statements from witnesses to two separate occasions of sleepwalking; witnesses must be military members and there must be at least two witnesses for each episode of sleepwalking. A psychiatric evaluation (prepared by a psychiatrist or a clinical psychologist or, if neither of these is reasonably available, a flight surgeon or other medical officer) should convincingly establish the absence of psychiatric illness and other conditions which would warrant medical or other administrative processing if the case is to be submitted solely under this Article.

2. *Enuresis.* Enuresis requires a urologist's evaluation.

3. *Personality Disorders.* Personality disorders are not, in and of themselves, cause for processing for separation. The personality disorder must render the member incapable of serving adequately; there must be documented interference with performance of duty persisting after the member has been counseled about the deficiencies and been afforded an opportunity to overcome them. Administrative counseling must be documented, along with the Notification Procedure (MILPERSMAN 3640200). Processing for separation because of a personality disorder under MILPERSMAN 3620200 requires that the personality disorder diagnosis must be established by either a psychiatrist or a clinical psychologist and that the report of that clinician's evaluation, concluding that the disorder is of such severity as to preclude expectation of adequate service, be a part of the package submitted for consideration by the Commander, Naval Military Personnel Command. Previously, the instruction governing administrative processing for malperformance attributable to a personality disorder entrusted the establishment of the diagnosis to flight

U.S. Naval Flight Surgeon's Manual

surgeons and other nonpsychiatrist medical officers; the current Article calls for evaluation by either a psychiatrist or a clinical psychologist. This does not, however, mean that the flight surgeon's role in the handling of such problems has been eliminated; to the contrary, the flight surgeon can contribute immeasurably by counseling the involved member and attempting to help him or her through the maturation process toward the goal of effective service, by advising the chain of command of appropriate measures which might facilitate that process, and by performing at least an informal psychiatric evaluation and advising the command of the likely outcome of formal referral to a psychiatrist or psychologist (this would be of greatest value to commands deployed to areas where psychiatrists and psychologists are not readily available). This section in MILPERSMAN 3620200 concludes with the admonition that, if separation is warranted on the basis of either unsatisfactory performance or misconduct, the member should be processed under whichever of those reasons applies regardless of the presence of a personality disorder.

4. *Motion or Air Sickness.* Motion or air sickness as a cause for processing herein requires the report of an otolaryngology consultation and a copy of Health Record entries relating to treatment of the condition. In addition, the degree to which the condition has interfered with performance of duty should be clear.

5. *Allergies.* Allergies causing substantial interference with the effective performance of duty may lead to processing under this Article. The submitted package must include an evaluation by an allergist or, if the latter is not readily available, a specialist in general internal medicine.

6. *Excessive Height.* Excessive height to which either incompatibility with continued naval service or performance or safety concerns are attributed may be the basis for administrative processing under MILPERSMAN 3620200. For reasons which are not explained in the Article, evaluation by an orthopedic surgeon must be part of the submission.

7. *Obesity or Weight Control.* Obesity or weight control problems can lead to processing of Navy members under MILPERSMAN 3620250, a summary of which appears below. The Marine Corps processes such members by reason of Unsatisfactory Performance.

8. *Alien.* Aliens who no longer wish to serve are the subject of MILPERSMAN 3620260, discussed below.

Voluntary Disenrollment from, or failure to meet the requirements for completion of, any Navy officer candidate program can lead to administrative processing for separation under this article (MILPERSMAN 3620200).

Disposition of Problem Cases

Members may not be separated by reason of obesity or weight control, parenthood, or personality disorders unless there have been documented efforts at rehabilitation. Separation should not be initiated until the member has been counseled and afforded an opportunity to overcome the deficiencies. Efforts must be documented in the member's Service Record as follows: written notification of the deficiencies; specific recommendations for corrective action; explanation of any assistance available to the member; thorough exposition of the consequences of failure to correct the problem(s); and documentation of the outcome of the member's having been afforded a reasonable opportunity to pursue the recommended remedial action.

MILPERSMAN 3620210 (6407) Separation of Enlisted Personnel at the Convenience of the Government on the Basis of Dependency or Hardship

This article details the procedures by which an enlisted member may request discharge or release to inactive duty because of a severe hardship affecting his or her immediate family. In order to qualify for separation, the hardship must have occurred or been severely aggravated since the member's service entry, the member and his or her family must have exhausted every reasonable effort to alleviate the hardship, there must be no reasonable expectation that the member could resolve the problem during a period of leave or temporary duty, and there must be a confident expectation that the member's discharge or release from active duty would eliminate or materially alleviate the hardship. The Article lists various circumstances under which separation for this reason is not appropriate, several considerations which may not be used to justify disapproval of a request, and a few "extraordinary circumstances" for which processing would be most appropriate. If separation is approved, characterization of service would be Honorable, General, or Entry Level Separation (see MILPERSMAN 3610300).

MILPERSMAN 3620220 (6408) Separation of Enlisted Personnel at the Convenience of the Government on the Basis of Pregnancy and Childbirth

The procedures by which a female member's request for separation on the basis of pregnancy or childbirth is handled are specified in this Article. There is a list of circumstances under which such a request would normally be disapproved; excepting such cases, commanding officers are authorized to effect separation at the local level. Characterization of Service will be either Honorable, General, or Entry Level Separation, as detailed in MILPERSMAN 3610300. Note that when a member is found to be pregnant during the initial training period and the pregnancy is certified to have existed prior to entry, separation shall be by reason of Erroneous Enlistment (MILPERSMAN 3630380,1a(1)), vice the present Article. Also, if delivery occurs before the member has an approved separation date, processing under the present Article is no longer appropriate: MILPERSMAN 3630300 and/or 3620210 would then apply.

MILPERSMAN 3620240 (6410) Separation of Enlisted Personnel at the Convenience of the Government on the Basis of Designation as a Surviving Family Member (Inductees Only)

An enlisted member inducted into the Armed Forces under the provisions of the Military Selective Service Act (the "draft"), who has not reenlisted or otherwise voluntarily extended his or her period of active duty, and whose father, mother, brother, or sister was killed in action, died while on active duty, died as a result of injuries received or illness incurred while on active duty, or is in a captured or missing status may apply for administrative discharge under this Article -- unless Congress has declared war or a national emergency, or the member is the subject of Court-Martial proceedings. Characterization of service will be Honorable, General, or Entry Level Separation, as in MILPERSMAN 3610300.

MILPERSMAN 3620245 Separation of Enlisted Personnel at the Convenience of the Government on the Basis of Being a Sole Surviving Son or Daughter

An enlisted member may apply for separation if he or she is the only remaining son or daughter of a family in which, by reason of service in any of the Armed Forces, the father or mother or one or more sons or daughters was killed in action, died as a result of illness or injury, is captured or in a missing-in-action status, or is permanently 100 percent disabled, or is hospitalized and unable to be employed as a result of service-connected disability. This request will normally be approved unless the member is the subject of Court-Martial proceedings, or Congress has declared war or national emergency. The request for separation may be initiated by either or both parents but, in such cases, it will not be approved if the member wishes to remain on active duty. As an alternative to administrative separation, a member designated a sole surviving son or daughter may request (or the Navy may direct) conferring an "L-9" limited duty classification designator; this will result in assignment only to duties not involving combat. The limited duty classification designator, vice separation, should be expected when the member's sole surviving son or daughter status is based on the other family member's being in a captured or missing-in-action status. There are provisions for a member to waive sole surviving son or daughter designation; reinstatement may be requested subsequently. When separation is directed, characterization of service will be either Honorable, General, or Entry Level Separation (MILPERSMAN 3610300).

MILPERSMAN 3620250 Separation of Enlisted Personnel at the Convenience of the Government on the Basis of Obesity

This Article directs that separation should be considered when a member demonstrates lack of interest or effort or is for any other reason unsuccessful in his or her attempt to reduce or maintain the weight or body fat percentage specified in the physical readiness standards set forth in

Disposition of Problem Cases

OPNAVINST 6110.1. Administration of the Health and Physical Readiness Program is detailed in MILPERSMAN 3420440; the present Article addresses only the administrative disposition of those members who fail to comply with that Program. The package to be submitted must include the commanding officer's certification that the member is militarily unsuitable for retention due to his or her appearance or inability to perform duties due to obesity; a copy of the Administrative Remarks (Page 13) placing the member on the Weight Control Program; a summary of the action taken by the command, the member's progress, and the counseling offered (outlined in MILPERSMAN 3420440); a copy of the Notification Procedure and letter of transmittal (MILPERSMAN 3640200); documentation by a medical officer that the member's obesity is the result of dietary indiscretion (this should include reports of the member's progress and any consultation reports regarding the member's weight condition); and a statement by the member either rebutting or consenting to the separation recommended due to obesity. If separation is effected, characterization of service will be Honorable, General, or Entry Level Separation, as outlined in MILPERSMAN 3610300.

MILPERSMAN 3620260 Separation of Enlisted Personnel at the Convenience of the Government -- Alien

A member who is neither a natural-born nor a naturalized citizen is an alien and, if he or she no longer wishes to serve, may be separated after approval by the Commander, Naval Military Personnel Command. An alien's request for separation will normally be denied when obligated service for funded education or additional training has not been completed, when the member is serving in a specialty in which there is a significant personnel shortage, or when the member has received special compensation (such as the Selected Reenlistment Bonus) during the current enlistment. An alien requesting separation under the provisions of this Article must acknowledge awareness that, if the separation is approved, he or she will be permanently ineligible to become a citizen of the United States (8 U.S.C. 1426). No alien may be separated under the provisions of this Article if disciplinary action is pending. Characterization of service if separation is approved will be Honorable, General, or Entry Level Separation, as described in MILPERSMAN 3610300.

MILPERSMAN 3620270 (Chapter 8) Separation of Enlisted Personnel by Reason of Physical Disability

This Article establishes the mechanism for disposition of a member who has been found not fit for duty ("unable, because of disease or injury, to perform the duties of his or her rank in such a manner as to reasonably fulfill the purpose of employment on active duty") by reason of a disability which existed prior to entry on active duty and was not aggravated by service. In these cases, the member is entitled neither to disability compensation nor to severance pay. A Medical

Board must affirmatively and specifically express the opinion that the member is unfit, the convening authority of the Board must concur in that opinion, the member must waive his or her right to a formal hearing before a Physical Evaluation Board, and there may be no disciplinary action pending. If either the convening authority does not concur in all opinions of the Board or the member does not waive his or her right to a hearing, the Medical Board must be forwarded to the Central Physical Evaluation Board. If the member had entered the service under a waiver of the physical standards for the defect which now is the basis of the Medical Board's recommendation for separation, the Board must be submitted for departmental review, as specified in the *Manual of the Medical Department*. When separation is effected, characterization of service will be Honorable, General, or Entry Level Separation (MILPERSMAN 3610300).

MILPERSMAN 3620275 Separation of Enlisted Personnel on Inactive Duty by Reason of Physical Disability

This Article explains the procedures for disposition of Naval Reservists who are found to be not physically qualified for active duty or for retention in the Naval Reserve. SECNAVINST 1770.3 provides specific guidance regarding separation of Reservists incurring a physical disability while on active duty for training, inactive duty training (drill), or active duty of 30 days or less.

MILPERSMAN 3630380 (6204) Separation of Enlisted Personnel by Reason of Defective Enlistments and Inductions -- Erroneous Enlistment

This Article defines an erroneous enlistment, reenlistment, induction, or extension of enlistment as one which would not have occurred if the relevant facts had been known or if appropriate directives had been followed; there must have been no fraudulent conduct on the part of the member, and the defect(s), must not have changed in any material respect from the time of the error until processing was initiated. If the issue involves only pregnancy, processing may proceed without Medical Board action under this Article; otherwise, a Medical Board must establish that in his or her present condition the member is "not physically qualified" in accordance with the physical standards for enlistment or induction, that upon entry on the current period of active service the member did not meet the minimum physical standards, and that the member has no disqualifying physical disability incurred in, or aggravated by, active military service. The approved findings of the Medical Board must be only that the member is "not physically qualified" in accordance with prevailing physical standards; if there is the additional finding of medical unfitness by reason of physical disability, processing under this Article is not appropriate. A member may not be declared unfit for military service after entry because of disabilities which existed at the time of acceptance if these have remained essentially unchanged and have not interfered with his or her performance of effective military service. If a waiver had been granted for

Disposition of Problem Cases

the defect for which the member is now considered to be not physically qualified, the *Manual of the Medical Department* requires that a Medical Board report be submitted for departmental review. A separate procedure is specified when the problem is detected immediately after the swearing-in ceremony at a Military Entrance Processing Station (MEPS). Members are entitled to submit a statement for consideration by the Convening Authority of the Medical Board, but they have no right to a hearing before the Physical Evaluation Board. Processing for separation is not required if the member's commanding officer recommends retention and either the defect is no longer present or a waiver (for a nonmedical defect) is obtained from the Naval Military Personnel Command. If separation is approved, characterization of service will be Honorable, unless an Entry Level Separation or an Order of Release from Custody and Control of the Armed Forces by reason of void enlistment is directed (see MILPERSMAN 3610300).

MILPERSMAN 3620283 (6402) Separation of Enlisted Personnel by Reason of Defective Enlistments and Inductions -- Defective Enlistments

A defective enlistment exists when a member reasonably relied upon material misrepresentation by recruiting personnel and was induced to enlist by a commitment for which he or she was not qualified, when the member received a written enlistment commitment from recruiting personnel which cannot be fulfilled by the naval service, or when the enlistment was involuntary -- induced by fraud, duress, or undue influence and not the product of a free and unconstrained choice. Most often, this will involve members enlisted with a guarantee of training in a particular rating, occupational field, or advanced program who are found to be disqualified for the program specifically promised. To be processed here, the member must not knowingly have participated in the creation of the defective enlistment, must bring the defect to the attention of appropriate authorities within 30 days of the time the defect was (or reasonably should have been) discovered, and must request separation instead of other corrective action. Prior to discharge, members whose enlistments were defective will be advised of alternative programs for which they are qualified and will be encouraged to remain in the Service, but retention shall be effected only with their full concurrence. If separated, the member's service will be characterized as Honorable unless an Entry Level Separation or an Order of Release from the Custody and Control of the Military Services is effected (see MILPERSMAN 3610300).

MILPERSMAN 3620285 (6204.1 & 6107.3b) Separation of Enlisted Personnel by Reason of Defective Enlistments and Induction -- Minority

A member under the age of 18 is a minor. The minimum age for enlistment is 17. Written consent of a parent or legal guardian must be obtained prior to the enlistment of a minor into any component of the Navy. The enlistment of a minor under the age of 17 is void and the member

shall be discharged, regardless of whether a parent or guardian requests this. If a minor is at least 17 years old, had enlisted without proper consent, and the parent or legal guardian requests discharge within 90 days of enlistment, separation shall be authorized unless the member will no longer be a minor by the time of discharge. A minor who is at least 17 years old, who enlisted without proper consent, and who has served more than 90 days will normally be retained, unless his or her commanding officer recommends separation under MILPERSMAN 3630380. The enlistment of a minor with false representation as to age or without proper consent will not, in and of itself, be considered a fraudulent enlistment. The Notification Procedure (MILPERSMAN 3640200) shall be used to initiate processing. When the minor is at least 17 years old, the commanding officer is required to make a statement concerning whether, in his or her opinion, the member is sufficiently mature for retention; a negative opinion in this respect is to be accompanied by an evaluation by a qualified psychiatrist (when a psychiatrist is not reasonably available, evaluation by a medical office is to be submitted). A minor under age 17 when separated shall be issued an Order of Release from the Custody and Control of the Armed Forces by reason of Void Enlistment or Induction (MILPERSMAN 3610300); a minor who is 17 years old when separated by reason of minority shall receive an Entry Level Separation (also MILPERSMAN 3610300).

MILPERSMAN 3620290 Administrative Discharge Procedures for Enlisted Personnel Assigned to Limited Duty

Limited duty is intended to protect from premature discharge or additional harm members who are considered assets to the service, who have been injured or become ill and who cannot perform the full duties of their rate. Limited duty is not a right, nor is it a bar to discharge for certain administrative (MILPERSMAN 3630100 through 3630900) or punitive reasons. A member in a limited duty status who is not considered to be an asset to the service (because of one or more reasons for administrative separation) may be separated when maximum benefit of inpatient hospitalization and treatment have been achieved and when retention is considered not to be in the best interest of the service. Members processed for punitive or administrative (MILPERSMAN 3630100 through 3630900) separation shall not be afforded Medical Board action; such discharges take precedence over medical disability and limited duty consideration. As an exception to this, a Medical Board shall be submitted whenever a question of mental competence arises.

MILPERSMAN 3630100 (6204.3) Separation of Enlisted Personnel by Reason of Defective Enlistments and Inductions due to Fraudulent Entry in Naval Service

A member may be separated under the provisions of this Article for having entered fraudulently and through knowingly false representation or deliberate concealment of any of the qualifica-

Disposition of Problem Cases

tions or disqualifications prescribed for entry. The Notification Procedure (MILPERSMAN 3640200) will be used to initiate processing except when service will be characterized as Other Than Honorable, in which case the Administrative Board Procedure (MILPERSMAN 3640300) is necessary. When the command recommends retention, and either the defect is no longer present or the defect is waivable and a waiver has been obtained from the Commander, Naval Military Personnel Command, processing for separation is not necessary. If the information concealed or misrepresented includes preservice homosexuality, processing shall be in accordance with MILPERSMAN 3630400, except that characterization of service shall be as outlined in the present Article -- General or Entry Level Separation (MILPERSMAN 3610300) unless a discharge under Other Than Honorable Conditions is warranted. There is no provision for suspension of separation initiated for this reason.

MILPERSMAN 3630200 (6205) Separation of Enlisted Members by Reason of Entry Level Performance and Conduct

This Article authorizes the separation of a member in entry level status (in essence, during the first 180 days of service -- see MILPERSMAN 3610200) when he or she has been found unqualified for further service because of unsatisfactory performance or conduct; this can be manifested by incapability, lack of reasonable effort, failure to adapt to the military environment, minor disciplinary infractions, or failure to satisfactorily complete indoctrination training. Prior to processing, the member must have been counseled in writing, with specific recommendations for corrective action and a comprehensive explanation of the consequences of failure to undertake the recommended corrective action, and there must be a reasonable opportunity for the member to respond to this counseling. The Notification Procedure (MILPERSMAN 3640200) is used. Characterization of service is Entry Level Separation. Nothing precludes processing a member in entry level status for separation under the provisions of other Articles, if appropriate.

MILPERSMAN 3630300 (6206) Separation of Enlisted Personnel by Reason of Unsatisfactory Performance

This Article provides for the separation of enlisted personnel whose performance of assigned tasks and duties is not contributory to unit readiness or mission accomplishment (as documented in a Page 13 entry in the Service Record) as well as those who have failed to maintain required proficiency in rate as reflected by two consecutive enlisted performance evaluations (either regular or special) with unsatisfactory marks for professional factors of 1.0 in either military or rating knowledge performance or with an overall evaluation of 2.0 or lower (corresponding thresholds apply for Marine Corps enlisted evaluations). Separation processing may not be in-

initiated until the member has been counseled in writing, has received specific recommendations for corrective action, a comprehensive explanation of the consequences of failure to correct the deficiencies, and has had a reasonable opportunity to undertake the recommended corrective action. There is an injunction against processing for separation by this reason when the member is in entry level status or when processing by reason of misconduct is appropriate. The Notification Procedure MILPERSMAN 3640200 shall be used.

MILPERSMAN 3640400 (6207) Separation of Enlisted Personnel by Reason of Homosexuality

This Article begins by explaining the incompatibility of homosexuality with military service. Among the concerns cited to support the policy of not enlisting or retaining homosexuals or bisexuals are: impairment of mission accomplishment; degradation of discipline, good order, and morale; inability to foster trust and confidence among members and to ensure integrity of the system of rank and command; disruption to assignment policies and world-wide deployment of members who often must live and work under close conditions affording minimal privacy; and negative impact on recruiting, retention, and acceptability of the Navy by the public. Also listed as a reason for barring homosexuals is to prevent breaches of security; this would seem to be a valid consideration only because homosexuality is forbidden and therefore homosexuals could be vulnerable to security compromise. A "homosexual" is defined as a person, regardless of sex, who engages in, desires to engage in, or intends to engage in homosexual acts (bodily contact, actively undertaken or passively permitted, between members of the same sex for the purpose of satisfying sexual desires); a "bisexual" is a person who engages in, desires to engage in, or intends to engage in both homosexual and heterosexual acts. Conduct or statements which occurred during a previous enlistment or prior to enlisting should lead to processing under MILPERSMAN 3630100; only current service homosexuality should be addressed under the present Article. This Article authorizes separation if the member engaged in, attempted to engage in, or solicited someone else to engage in a homosexual act (unless this was a departure from the member's normal behavior; is unlikely to recur; was not accomplished by force, coercion, or intimidation; and the member does not desire or intend to engage in homosexual acts, and his or her continued presence in the naval service is consistent with proper discipline, good order, and morale), admitted that he or she is a homosexual or bisexual (unless it is found that this is not true), or marries or attempts to marry a person of the same biological sex (unless it is found that the member is not homosexual or bisexual and that the purpose of the marriage was to avoid or terminate naval service). The Administrative Board Procedure (MILPERSMAN 3640300) is used unless during the current period of service the member attempted, solicited, or committed a homosexual act by using force, coercion, or intimidation; or was involved with a person under age 16, with a subordinate, in public view, for compensation, aboard a naval vessel or aircraft, or otherwise such as to have an adverse impact on discipline, good order, or morale similar to that of such behavior aboard a vessel or air-

Disposition of Problem Cases

craft. Under any of the aggravating circumstances listed directly above, a separation characterized as under Other Than Honorable Conditions would be appropriate; also, if conditions warrant, referral of the case to trial by court-martial is authorized.

MILPERSMAN 3630500 (6208) Separation, of Enlisted Personnel by Reason of Drug Abuse Rehabilitation Failure

This Article provides for the administrative separation of a member who was referred by his or her commanding officer to a formal program of rehabilitation for personal drug abuse (see OP-NAVINST 5350.4) and who fails (through inability or refusal) to participate in, cooperate in, or successfully complete such a program, when either there is a lack of potential for continued naval service or long-term rehabilitation is necessary and the member is transferred to a civilian medical facility. This Article anticipates the occasions when multiple processing will be appropriate (e.g., for this and other reasons such as misconduct due to drug abuse). The administrative package, when forwarded, must include the commanding officer's assessment as to whether the member is or is not drug dependent; helping to formulate that determination is one among the many ways in which the flight surgeon might assist the command and its members with problems of this type. The Notification Procedure (MILPERSMAN 3640200) is used and characterization of service will be the type warranted by the Service Record (Honorable or General) or Entry Level Separation as specified in MILPERSMAN 3610300.

MILPERSMAN 3630550 (6209) Separation of Enlisted Personnel by Reason of Alcohol Abuse Rehabilitation Failure

This Article is, in essence, a verbatim replication of MILPERSMAN 3630500 (again citing OP-NAVINST 5350.4) except that the member's problem here is with alcohol instead of other drugs. There is no stated requirement here for the commanding officer to address specifically the issue of dependence, but MILPERSMAN 3610200.1 calls for a Substance Abuse Dependency Evaluation in both types of cases.

MILPERSMAN 3630600 (6210) Separation of Enlisted Members by Reason of Misconduct

1. Minor disciplinary infractions: a series of at least three but not more than eight minor violations of the UCMJ (not drug-related, none warranting a punitive discharge, and not more than two periods of unauthorized absence) documented in the Service Record and disciplined by not more than two punishments under the UCMJ during the current enlistment. If the case exceeds these limits, it must be processed for pattern of misconduct or commission of a serious offense (below); drug abuse cases should be processed under MILPERSMAN 3630620.

U.S. Naval Flight Surgeon's Manual

2. A pattern of misconduct -- discreditable involvement with civil or naval authorities during the current enlistment evidenced by one or more of: two or more minor civilian convictions; three or more punishments under the UCMJ; a combination of the preceding; three or more periods of unauthorized absence; nine or more minor violations disciplined by punishment under the UCMJ; or an established pattern of dishonorable failure to pay just debts, to contribute adequate support to dependents, or to comply with orders, decrees, or judgments of a civil court concerning the support of dependents.

3. Commission of a serious military or civilian offense if the specific circumstances of the offense warrant separation and if the *Manual for Courts Martial* would authorize a punitive discharge for the same or a closely related offense.

4. Conviction, or action which is equivalent to a finding of guilt, by civilian authorities when the specific circumstances of the offense warrant separation and either the UCMJ would authorize a punitive discharge for the same or a closely related offense or the sentence includes confinement for six months or more (regardless of suspension or probation).

At least one counseling attempt (including written notification, specific recommendations, and a comprehensive explanation of the consequences of failure) must be documented on Page 13 of the member's Service Record and there must be a reasonable opportunity for the member to undertake the recommended corrective action before separation processing may proceed -- unless the reason for processing is commission of a serious offense or a civilian felony conviction. Misconduct involving homosexuality should be processed under MILPERSMAN 3630400; fraudulent entry, 3630100; and drug abuse, 3630620. A reservist on active duty within two years of retirement eligibility may not be separated involuntarily unless this action is approved by the Secretary of the Navy. The Notification Procedure (MILPERSMAN 3640200) may be used when citing members for minor disciplinary infractions or when characterization of service under Other Than Honorable Conditions is not warranted; otherwise, the Administrative Board Procedure (MILPERSMAN 3640300) should be used when processing members for separation by reason of Misconduct. Characterization of service for separations effected under this Article will normally be under Other Than Honorable Conditions. Characterization as General may be assigned when appropriate, but Honorable will not be authorized unless the Commander, Naval Military Personnel Command or higher authority concurs that the record is otherwise so meritorious that any lesser characterization would be inappropriate.

MILPERSMAN 3630620 (6210) Separation of Enlisted Members by Reason of Misconduct due to Drug Abuse

Separation under this Article may be based upon one or more military offenses or civilian con-

Disposition of Problem Cases

victions (including actions tantamount to a finding of guilt) for drug abuse (illegal) or wrongful use or possession of a controlled substance, drug trafficking (sale or transfer of a controlled substance or possession with intent to sell or transfer), or drug paraphernalia (illegal or wrongful use, possession, sale, or transfer of drug paraphernalia). There is an injunction to consult OP-NAVINST 5350.4 to determine when processing for separation is mandatory. In addition to whatever other ways they might help the command or affected members with such problems, flight surgeons should expect to become involved in the administrative processing of members under this Article because a medical officer's opinion or a CAAC assessment of the member's drug dependence (based on an evaluation conducted subsequent to the most recent drug incident) must be included with each case submission. A reservist on active duty within two years of retirement eligibility may not be released involuntarily unless this is approved by the Secretary of the Navy. The Administrative Board Procedure (MILPERSMAN 3640300) shall be used in all cases except when the sole basis for separation is drug abuse evidenced by urinalysis testing (fitness for duty); inasmuch as the results of these tests can not be used to characterize service, the commanding officer may choose to utilize the Notification Procedure (MILPERSMAN 3640200). Normally, characterization of separation will be under Other Than Honorable Conditions except when the type warranted by the Service Record (Honorable or General) or Entry Level Separation is required by processing based solely on urinalysis testing (fitness for duty) results.

MILPERSMAN 3630650 (6419) Procedures for Processing Enlisted Personnel for Separation in Lieu of Trial by Court-Martial

This Article provides that a member who has been charged with an offense for which a punitive (Bad Conduct or Dishonorable) discharge is authorized, and whose commanding officer has determined to be unqualified for further naval service, may request reduction in rate to E-3 (if currently an E-4 or above) and administrative separation under Other Than Honorable Conditions in lieu of trial by Court-Martial. Members should understand that a formally submitted request may not be withdrawn unless the officer exercising General Court Martial jurisdiction in the case concurs, and that any approved separation by this reason will be a bar to reentering any military service. Flight surgeons will be involved in such cases at least to the extent of providing, for inclusion in the package submitted to higher authority, a report of medical examinations and either a written statement that a psychiatric evaluation is not warranted or a copy of a psychiatric evaluation. Referral to a psychiatrist may be made only after evaluation by a nonpsychiatrist medical officer and is, in general, only appropriate when there is a question of competence: could the accused member adhere to the law at the time of the alleged offense. and is he or she able to understand the nature of the judicial or administrative proceedings? Characterization as General may be approved by the Commander, Naval Military Personnel Command and, in some circumstances, an Entry Level Separation may be authorized.

MILPERSMAN 3630700 (6212) Separation of Enlisted Personnel by Reason of Security

When retention of a member is clearly inconsistent with the interest of national security under terms of the "Personnel Security Program" (DOD 5200.2-r) and separation cannot be initiated under any other MILPERSMAN Article, commanding officers may seek approval of the Commander, Naval Military Personnel Command to initiate separation processing by reason of this Article.

*** MILPERSMAN 3630800 Unsatisfactory Participation in Ready Reserve**

*** MILPERSMAN 3630810 Separation from the Delayed Entry Program**

MILPERSMAN 3630900 (6214) Separation in the Best Interest of the Service

The Secretary of the Navy may direct the separation of any member prior to the expiration of his or her term of service after determining this to be in the best interest of the naval service. This shall not be used as the reason for separation if processing under any other Article would be appropriate. Characterization of service will be Honorable or General (MILPERSMAN 3610300) unless an Entry Level Separation is appropriate.

MILPERSMAN 3640200 (6303) Notification Procedure

This Article specifies the procedure whereby a member being processed for separation is formally notified of the reasons, the possible outcome, the least favorable discharge which could ensue, and the several rights to which he or she is entitled (e.g., to obtain copies of all documents forwarded, to submit a statement in his or her own behalf, to consult with counsel (except under unusual circumstances), and to request an Administrative Board if more than six years of active and/or Reserve service have been accrued).

MILPERSMAN 3640308 (6304) Administrative Board Procedure

This Article establishes the requirement and the procedures for the convening of an Administrative Board of at least three well-qualified members to conduct a hearing and develop carefully considered findings and recommendations when a member with six or more years of service who is being processed under the Notification Procedure requests this, when the proposed reason for separation requires such a board, and when the proposed characterization of service is under Other Than Honorable Conditions.

Disposition of Problem Cases

We shall conclude by listing a few of the Articles which might be of interest from those comprising the remainder of MILPERSMAN Chapter 36:

- * MILPERSMAN 3640350 Information on Administrative Board Procedures.
- * MILPERSMAN 3640370 CNMPC Action on Administrative Board Recommendations.
- * MILPERSMAN 3640410 Appointment/Disenrollment Service Academies (not USNA).
- * MILPERSMAN 3640415 Midshipmen Disenrolled from the Naval Academy.
- * MILPERSMAN 3640420 Discharge by Sentence of Court-Martial.
- * MILPERSMAN 3640440 Release from Active Duty of Reserve and Retired Personnel.
- * MILPERSMAN 3640450 Lost Time from Active Duty which Must be Made up.
- * MILPERSMAN 3640455 Recoupment of Reenlistment Bonus.
- * MILPERSMAN 3640472 Information Provided at Separation about Claims for Compensation, Pension, or Hospitalization.
- * MILPERSMAN 3640474 Physical Examination for Separation.

SECTION III: AVIATION DISPOSITION

Introduction

What is done with the problem patient - the aviator, N.F.O., air traffic controller, or enlisted crew member whose medical problems (1) do not render him unfit for further service, (2) suggest a possible impact on aeromedical safety, but (3) do not fit neatly into a category which all concerned agree should change his or her flying status? The purpose of this section is to assist in determining whether or not there is a problem, and if so, what to do.

Identification of Problem Cases

Whether the evaluation is as casual as a conversation with a pilot in the passageway, or as formal as a Special Board of Flight Surgeons, every evaluation performed by a flight surgeon seeks to answer two questions: (1) is the individual safe to perform his aviation duties, and (2) is the individual likely to remain so in the future? General agreement could be expected on the not-physically-qualified (NPQ) status of the young ensign who suffers a severe unilateral hearing loss very early in the pilot training syllabus. Disagreement might be expected, however, about the fate of a lieutenant commander with 14 years of service and several fleet tours who suffers the same problem. He differs from the ensign in several ways:

1. The Navy's investment in dollars is considerably greater.
2. His experience is obviously greater.
3. The aviation experience of the lieutenant commander might allow him to compensate for the defect.
4. The future demands the Navy will make on the individual's services are different. An ensign in the training command is usually required to be qualified for all assignments without restriction; a lieutenant commander in the patrol community may be competitive for promotion and command assignment even if he is in a permanent Medical Service Group III category.

Fortunately, there are avenues of assistance available in identifying problem cases and in resolving the problems. The most obvious is close at hand - other flight surgeons at the local activity. In effect, the flight surgeon should do what any clinical physician is likely to do with a difficult patient - seek an independent consultative opinion.

Disposition of Problem Cases

The clinical departments at the Naval Aerospace Medical Institute (NAMI), Pensacola, Florida, can be of considerable help. Not only do the members of the staff have specialized clinical knowledge, they also possess the historical experience of previous cases in their clinical field and referrals to the Special Board of Flight Surgeons.

Finally, there is the Bureau of Medicine and Surgery. Inasmuch as the staff of Code 23 will make the final recommendation to the Bureau of Naval Personnel or the Commandant of the Marine Corps, it may be worthwhile to discuss the case with them (preferably with Code 236 at the Naval Aerospace Medical Institute, Pensacola, Florida) before much effort has been expended.

There are many situations in which no solution exists on which all can agree. However, personnel officers will not maintain an aviator in a "limbo" status for an indefinite period awaiting a definitive decision. The result may be that the ultimate resolution will be reached by Code 23 at BUMED, acting for the Surgeon General.

Fitness for Duty

The first question to be asked in the evaluation of a problem patient is, "Is the individual medically suited for continued active service (i.e., is he or she fit for duty)?" Normally, the medical board action required to resolve this question is the province of the nearest naval hospital, and its advice, both clinical and administrative, should be sought. A full discussion of medical boards and physical evaluation boards is to be found earlier in this chapter. However, two points should be understood about the finding of "fit or unfit" for aviation duties:

1. A finding of "unfit for duty," whether temporary (Limited duty) or permanent, automatically implies a finding of not physically qualified for all aviation duties. Although the possibility exists for a waiver, to allow an individual on limited duty to continue in flying status under most circumstances should not be considered.
2. A finding of not physically qualified for any or all aviation duties in no way implies a finding of "unfit for duty."

Although the two determinations may appear to overlap since a given diagnosis may lead to finding of both NPQ and "unfit," the two determinations must be considered as independent. The standards applied to the determination of "fit" are those of general service. It is relatively easy to conceive of a situation in which a patient might be unsafe to pilot an aircraft but safe medically to serve as a surface warfare officer. That individual would be NPQ for all aviation, but still "fit for duty."

Field Evaluation Boards

Once a flight surgeon has determined that a substantive question exists concerning an individual's suitability for continued flight status, it must be determined whether or not the individual is also physically qualified for flight status. If the initial event prompting consideration of a Field Evaluation Board is of a physical or psychological nature and is of such a degree as to make the individual not physically qualified for flight, then it is generally inappropriate to convene an FNAEB, FNFOEB, or FFPB. These problems are more appropriately addressed by a Local Board or a Special Board of Flight Surgeons (discussed separately).

Field Evaluation Boards are administrative proceedings designed to determine whether or not a naval aviator (FNAEB), flight office (FNFOEB), or flight surgeon (FNFSEB) are capable of adequately and safely performing all duties required of their designator. Possible events precipitating Field Board proceedings may include: (1) multiple "downs" during primary, advanced, or squadron NATOPS training flights, (2) pilot error resulting in a mishap, (3) demonstrated lack of proficiency in the fundamental principles or skills of one's designator, (4) unsafe flying practices not otherwise explained by a psychiatric or medical condition, or (5) a stated refusal or unwillingness to continue flying.

An FNAEB requires a minimum of three designated aviators and one flight surgeon. FNFOEB's require one designated NFO, at least two other designated members (NFO or NA), and one flight surgeon. In both cases, the flight surgeon member should not be the specified board member. The senior line member on the board must be senior to the member being evaluated. Results are forwarded through the chain of command to the Commander, Naval Military Personnel Command; and, are subject to appeal in accordance with (NAVMILPERSMAN 1410100, COMNAVVAIRLANTINST 5420.3, and COMNAVVAIRPACINST 1610.0).

Local Board of Flight Surgeons

Once a flight surgeon has determined that a substantive question exists about an individual's suitability for continued flight status, but that he or she remains fit for duty, consideration should be given to convening a Local Board of Flight Surgeons.

A Local Board conducts an informal administrative proceeding. Neither formal rules for procedure nor for the format of a report are specified, nor are they necessary. Several considerations should be remembered:

Disposition of Problem Cases

1. The report should be written in a narrative form, preferably chronologically. Where a particular body of information is contained in a clinical consultation or other report, there is no need to quote lengthy portions of the report. A summary will be sufficient, provided the basic report or consultation is included as an enclosure to the report of the Local Board.

2. Normally the case will be presented by the flight surgeon who had primary responsibility for management of the patient. While it is not necessary for other board members to examine the patient personally, it is important for the board to meet as a group with the patient. The patient should understand as much as possible about the medical problem and how the board feels this impacts flight safety. The patient should be given the opportunity to make any statement he or she wishes and to ask questions. The patient's written statement, if made, should be included as part of the board report.

3. Once a decision has been reached by the board, the patient should be informed what the recommendation of the board will be. Although not required by regulation, it is often advisable to give the patient a signed copy of the final report of the board.

4. Local Boards must submit their reports to NAMI, Code 42 via the patient's commanding officer. It must be remembered that the patient has certain appeal rights guaranteed to him by BUMED and BUPERS or the Commandant of the Marine Corps. Often these appeal rights will be exercised, even when the disposition is relatively straightforward to the aeromedical community, if the patient feels he has not been dealt with fairly and openly. Open discussions with the patient and involvement of the patient's commanding officer can prevent the wasted effort associated with the appeal of an obvious recommendation.

5. The report must be complete. Essentially, it must "sell" the recommendation of the board members. The final recommendation made by BUMED will be formed on the basis of the report without benefit of examining the actual patient and without any knowledge of his condition not contained in the report. If possible, the report should be reviewed by another flight surgeon who is unfamiliar with the case. If the report does not support the board's recommendation to that reviewer, it is unlikely to do so to the personnel in Code 23 at BUMED.

Unfortunately, many of the conditions that result in the convening of Local Boards lead to termination of flight status. Board members should always keep in mind that their action will have a significant impact on the future of the patient. Revocation of flight status means a decrease in pay, a significant change in life plans and career pattern, and frequently, a damaging blow to self-esteem. Board members should also be mindful of the fact that all aviators in the local area may feel threatened by the board's action. Therefore, the action of the board must not only be medically correct, it must be managed in a way that is understandable to the line community.

If the decision of the board is that a waiver is recommended, the member may be issued an up chit pending final disposition of the case by NAMI Code 42 and NMPC/CMC. In cases where the member has already been disqualified by NMPC/CMC for flight duties and the board recommends a waiver, the up chit should normally be withheld pending final disposition.

Special Board of Flight Surgeons

Occasionally, a case will arise that, due to its complexity or its uniqueness, warrants referral to the Special Board of Flight Surgeons (SBFS) at NAMI. The initial recommendation to refer to the SBFS can be made by anyone (including the patient or his command), but the final recommendation for referral can be made only by the Bureau of Medicine and Surgery, Code 02 or CO NAMI. Personnel attached to the Naval Aviation Training Command may be referred directly to the SBFS upon consultation with the commanding officer of NAMI. Normally, BUMED will recommend SBFS referral to the Chief of Naval Personnel or the Commandant of the Marine Corps, who will then direct the patient's commanding officer to order the patient to NAMI for evaluation by the SBFS. Unless the patient's commanding officer has made special arrangements with the Commanding Officer of NAMI, no patient should be sent to Pensacola prior to receiving official notification. This prevents unnecessary referrals, or referrals when NAMI is not prepared to evaluate the patient.

The SBFS was established to provide comprehensive evaluations of difficult aeromedical problems, unrestricted by the time and scheduling constraints found at clinical centers. Regardless of the presenting complaint, the patient is evaluated by all major departments at NAMI. Following the evaluation, the patient is presented to the SBFS, his problem is discussed, and a recommendation is formulated (with minority report(s) if indicated) for forwarding to the Bureau of Medicine and Surgery, Code 02.

The Special Board of Flight Surgeons consists of all designated naval flight surgeons in the Pensacola area, with the Commanding Officer, NAMI, as the senior member. The intent is to bring the maximum aeromedical experience to bear on specific cases. Normally, the evaluation begins on Monday, with presentation to the board on Friday of the same week. Although rarely necessary, the Commanding Officer of NAMI has the authority to extend the evaluation as he feels appropriate or to refer the patient elsewhere for evaluation prior to presentation to the board.

The recommendations of the SBFS are forwarded to BUMED for endorsement. Although normally forwarded to BUPERS or to the Commandant of the Marine Corps for implementation without change, BUMED has the prerogative to modify or reverse the recommendation as is felt appropriate.

Disposition of Problem Cases

No prior limits are placed on recommendations that can be made by the SBFS. Although the Board will normally attempt to fit its recommendation into feasible personnel alternatives, the Board is specifically not constrained by any published standard or restriction.

The Board of Flight Surgeons at the Bureau of Medicine and Surgery

The *Manual of the Bureau of Naval Personnel* guarantees an appearance before a Board of Flight Surgeons to every designated naval aviator or naval flight officer who is in danger of having his flight status revoked for medical reasons. The intent of this guarantee is considered to have been met when a patient appears before a Local Board or Special Board of Flight Surgeons, or when action is taken on the basis of a single-physician flight physical without the patient requesting appearance before a board. On occasion, a patient whose flight status has been revoked or limited will formally appeal the medical recommendation. The Chief of Naval Personnel or Commandant of the Marine Corps will then direct that the case be considered by the Board of Flight Surgeons at the Bureau of Medicine and Surgery. Where appropriate, a personal appearance by the patient before this board may be authorized.

The board is formally appointed by the Chief of Naval Personnel, and it is, in effect, the "court of last resort." Normally, the patient will be ordered to the National Naval Medical Center, Bethesda, Maryland, for any additional specialty evaluation felt to be indicated by the senior member of the board, the Director of Aerospace Medicine at BUMED. The specialty consultant is normally invited to sit with the board as an advisor, but does not vote on the final recommendation. The board, consisting of at least five members, of which at least three must be flight surgeons, and one must be a line officer, hears the case, interviews the patient, and votes on a recommendation. This recommendation to the Chief of Naval Personnel is considered to be final and is not subject to further appeal.

CONCLUSION

As with any clinical specialty, difficult cases represent the ultimate challenge to the discipline of aviation medicine. The challenge to find the right "answer" to a difficult aeromedical problem is much greater than is normally found in clinical medicine due to the complex interactions of nonmedical factors. A flight surgeon confronted with a difficult aeromedical problem should seek assistance, and seek it early in the process, from fellow flight surgeons, from clinical departments at NAMI, and from personnel in the Aerospace Medicine Division at BUMED.

CHAPTER 16

AEROMEDICAL EVACUATION

- Introduction
- Historical Background
- Physiological Factors Affecting Air Transportation
- Medical Conditions Requiring Special Management
- Evacuation Precedence and Classes
- Evacuation Decision Considerations
- Aircraft Capability Considerations
- Military Airlift Command Aeromedical Evacuation System
- Humanitarian Aeromedical Evacuation
- Patient Preparation
- Bibliography
- Appendix 16-A. Checklist for Aeromedical Evacuation Procedures

Introduction

Air transportation of sick and injured patients is commonly employed in military and civilian medical care systems. A thorough knowledge of aeromedical evacuation is essential for flight surgeons. Integrating aeromedical expertise with critical care medicine makes this area challenging for the practicing flight surgeon. Considerations beyond normal medical factors are required to ensure optimal patient outcome. The naval flight surgeon may find that these factors are especially difficult to evaluate or predict. Factors such as the tactical situation, aircraft availability, shore facility capability, weather conditions, and diplomatic considerations must be included in aeromedical evacuation planning.

Historical Background

The use of aeromedical evacuation dates from World War I. In 1915 twelve casualties were flown in unmodified service type aircraft from the battle area during the retreat from Serbia. The French instituted the first airplane ambulance service organization with six airplanes that could carry three litter patients each. More than 1200 patients were transported from the Atlas mountain area of Morocco during the Riffian War. In 1919, the British Royal Air Force first

transported casualties during the war against the Mad Mullah in Somaliland. Stretchers were placed inside the fuselage of a DH-9 aircraft. In 1923, some 359 patients were transported in Kurdistan.

In the United States, Captain George Gosman, MC, U.S. Army, had constructed an ambulance airplane near Pensacola, Florida in 1910. Requests for additional development funds were denied by the War Department. In 1918, at Gerstner Field, Louisiana, Major Nelson E. Driver, MC, U.S. Army and Captain William Ocker of the American Air Service modified the rear cockpit of a JN-4 aircraft to allow litter transport. During the next several years, ambulance aircraft were used by the U.S. Army on an emergency basis only, despite repeated urging by Army Medical Department officers for the routine use of transport airplanes for evacuating casualties in the event of war.

Large scale aeromedical evacuation first occurred during the Spanish Civil War (1936-1938) by the Germans. The sick and wounded of the Condor Legion were transported from Spain to Germany in JU-52 airplanes. Each aircraft was configured to carry ten litter cases and from two to eight ambulatory cases. The route involved flying over the Mediterranean to Northern Italy, then crossing the Alps at altitudes of up to 18,000 msl. The distance traveled varied between 1350 to 1600 miles with an elapsed air time of about ten hours. Oxygen was available and used while crossing the Alps. The extreme cold at altitude was a major difficulty because the airplanes did not have heating systems.

With the onset of World War II, most warring nations developed organized systems for aeromedical evacuation. The U.S. Army Air Corps formed medical air evacuation squadrons and established a school in 1942. Patients were transported by troop carrier aircraft within the various overseas theaters. Patients were returned to CONUS by the Air Transport Command. By the end of hostilities, the Army Air Corps had transported over 1.25 million patients.

The Korean Conflict of 1950-1953 saw the introduction of helicopters. They became the primary medical evacuation aircraft for the movement of casualties from the battlefield to the initial medical treatment facility. Helicopters also were used to transport patients between ships. By 23 February 1954, the U.S. Air Force Military Air Transport Service had transported over two million patients.

The Vietnam Conflict from 1965 to 1973 saw a much fuller exploitation of the helicopter for aeromedical evacuation. Combat search and rescue helicopters rescued aviators who were shot down. Helicopters in support of U.S. Marines and Army forces picked up the wounded soon after injury, and quickly transported them to definitive treatment facilities. Helicopter

Aeromedical Evacuation

aeromedical evacuation was considered a significant factor in the decreased mortality from wounds noted in that conflict. During World War II, about four percent of the casualties reaching medical treatment facilities died. During the Korean Conflict, this was reduced to two percent. The Vietnam conflict demonstrated fatality rates of one percent for casualties arriving at medical treatment facilities.

Physiological Factors Affecting Air Transportation

Any decision to evacuate a patient by air constitutes a major value judgment and should be made only after a thorough assessment of the medical benefits for the patient as compared to the hazards which might be associated with an evacuation flight. Prerequisites to this decision-making process are an in-depth understanding of the significant and unique risks imposed on patients during transport by aircraft. The flight surgeon must maximize patient outcome while minimizing patient risk.

There are no absolute medical contraindications to aeromedical evacuation. Much can be done by the flight surgeon to achieve a medically successful flight by preparation of the patient to better withstand the stresses and risk associated with flight or by manipulation of the patient's environment during the evacuation. These may include recommendation of flight level in an unpressurized aircraft or a specific pressurization profile in a pressurized aircraft in the case of dysbarism. Resuscitation and stabilization of the patient prior to evacuation cannot be overemphasized. These principles more than any other influence the final therapeutic outcome. On occasion, it may be prudent to delay evacuation in order to stabilize the patient. The space limitations, light, noise or other en route environmental conditions make routine monitoring and therapeutic procedures extremely difficult. Conversely, there may be tactical situations where delay is not feasible.

There are specific risks inherent in aeromedical flight which interact with medical status. These are related to physical properties of flight and associated factors which include: reduced atmospheric pressure, decreased oxygen tension, dehydration, motion sickness, fatigue and inactivity.

Reduced Atmospheric Pressure

Chapter 1, *Physiology of Flight*, describes the physiological effects of reduced atmospheric pressure. Although scheduled aeromedical evacuation flights are in pressurized aircraft, transport aboard nonpressurized aircraft and helicopters may be required. Rapid decompression may be experienced in pressurized aircraft. With the reduction of atmospheric pressure, the gases present

within the body tend to expand in accordance with Boyle's Law. If unable to escape, this pressure may rupture the containing walls of the cavity or impair circulation. The use of pressurized splints and MAST trousers pose similar problems. There is a well-documented incident in which MAST trousers were used to stabilize a wounded patient. After the flight, the patient's feet were pulseless which ultimately lead to bilateral lower extremity amputations. Ideally, the patient's cardiovascular status should be stabilized *before* air transport - unless precluded by battlefield conditions.

Decreased Oxygen Tension

The decreased oxygen tension associated with reduced atmospheric pressure may have significant adverse effects. Oxygen saturation is decreased only slightly at cabin altitudes in pressurized aircraft and in flight below 10,000 msl in unpressurized aircraft. However, this reduction can be critical in patients with marginal sea level tissue oxygenation. Patients, at risk, include those with anemia, recent acute blood loss, impaired pulmonary function, cardiac failure, organic heart disease or sickle cell trait. Essentially, low flow O₂ is practically never contraindicated.

Dehydration

The relative humidity at altitude is reduced in both pressurized and unpressurized aircraft. Dehydration may represent a risk to the unconscious, marginally hydrated patient. Patients with tracheotomies or those who must breath through their mouths may require humidified air or oxygen to prevent drying of respiratory secretions. Corneal drying in comatose patients may be averted by holding their eyelids closed with moistened cotton pads under eye shields.

Motion Sickness

There is a low incidence of motion sickness in large jet aircraft flying at altitude. However, motion sickness is more frequently encountered in helicopters and small aircraft operating at lower altitudes. Prior administration of antihistamines (25 to 50 mg of meclizine, 50 mg of cyclizine or 50 mg of dimenhydrinate) or "scopodex" (0.6 mg of scopolamine, 0.5 mg of d-amphetamine) may reduce symptoms if not medically contraindicated.

Fatigue and Inactivity

The ambulatory patient is sometimes transported aboard operational aircraft. In troop transport aircraft, the crowded seat configuration may discourage the patient from moving around during the flight. The enforced inactivity together with the anxiety and apprehension

Aeromedical Evacuation

associated with illness may produce more fatigue than would be expected. Some geographical considerations dictate aeromedical evacuation in ejection seat equipped aircraft (such as the US-3A in the Indian Ocean). Such missions require careful estimation of risk and benefits.

Medical Conditions Requiring Special Management

Cardiovascular Diseases

Supplemental oxygen should be available in flight and vasodilating drugs should be provided for those patients with symptomatic angina pectoris. Cabin altitude should not exceed 6,000 msl. Patients in congestive failure or with a history of any myocardial infarction within eight weeks of the acute episode must be evaluated on a case-by-case basis prior to transportation. The American College of Chest Physicians recommends that a cabin altitude not exceed 2,000 ft msl without supplemental oxygen for such patients.

Pulmonary Diseases

In patients with artificial, traumatic or spontaneous pneumothorax, movement by air should be deferred until radiographic studies demonstrate gas absorption. However, if the volume of gas remaining is small, restriction of altitude may enhance safe movement. Chest tubes may be left in place, but the Heimlich Valve must be applied. All flight attendants must be instructed in the proper use and function of the Heimlich valve. Patients should not be airlifted for 72 to 96 hours after chest tube removal and a roentgenogram should be obtained within 24 hours of flight to document full lung expansion. Advise the receiving facility of the importance of a repeat chest X-ray when the flight is completed.

Anemia

Patients with severe anemia or recent acute blood loss should have a hematocrit of above 30 percent prior to entering the aeromedical evacuation system. Hematocrit should be checked within 36 hours prior to flight. Patients with sickle cell trait pose additional risks. The use of a portable -SAO_2 Monitor in flight is recommended. The presence of an acute infectious process in those patients experiencing reduced oxygen partial pressure may precipitate a sickling crisis manifested by sickle cell anemia, vomiting, and left upper quadrant pain.

Gastrointestinal Diseases

Large unreduced hernias, volvulus, intussusception, and ileus are particularly susceptible to trapped gas phenomena. The circulation of the involved bowel loop may be severely compromis-

ed from trapped gas expansion. Air transport of these patients should usually be deferred until after definitive therapy and recovery. If transport is mandatory, it can usually be accomplished safely if altitude is restricted. It is conceivable that weakened viscus walls in peptic, amoebic, typhoid, or tuberculous ulcers could rupture from the pressures of gas expansion. Disruption of a surgical incision postoperatively due to intra-abdominal gas expansion is a threat. A 10 to 14-day convalescence period prior to aeromedical evacuation is recommended after abdominal surgery if possible. Colostomy patients evacuated by air require an extra supply of colostomy bags and dressings.

Orthopedic Patients

Casts should be clearly marked with the date of application and the nature of the fracture or surgical procedure performed. All casts, including the underlying web rolling and padding, should be bivalved to allow for soft tissue swelling at altitude. The air splints commonly used for initial stabilization pose a similar potential problem and must be constantly monitored during flight and adjusted to prevent any tourniquet effect. It is preferable to use wire-ladder splints, wood splints or plaster splints to stabilize fractures and severe sprains. Traction devices using swinging weights are unsuitable for use in flight from the standpoint of efficiency and safety. The Hare traction device is an extremely effective tension device for providing traction to the extremities. Paraplegic patients are generally moved on a Stryker frame to facilitate care and comfort during the flight. It is important that the entire frame accompany the patient since parts from various frames may not be interchangeable.

Eye Injuries and Diseases

Perforating damage to the globe is a common cause of aeromedical evacuation. Because the eye is normally liquid filled, it is not affected by barometric pressure changes. After surgery or trauma, air may be introduced. In such instances, a lower cabin altitude must be maintained in order to prevent barotrauma reopening the wound or separating the surgical incision. In patients having choroidal or retinal disease or injury, oxygen should be administered at cabin altitudes above 4,000 msl.

Ear, Nose, Throat Disease

The presence of an incidental upper respiratory infection may complicate aeromedical evacuations for other injuries or illnesses. Administration of decongestants may be considered to prevent barotrauma. Aeromedical evacuation of patients with facial fractures may be required. The facial sinuses may have been damaged and contain mixtures of air and fluid. The ostia may be

Aeromedical Evacuation

plugged. The patients may be unable to Valsalva due to medication, or impairment of dexterity or cognition. Such cases should be carefully evaluated.

Skull Fracture

Any patient with a skull fracture which extends into a paranasal sinus, external ear canal or middle ear must be carefully evaluated. The possibility of air having entered the cranial cavity must be excluded. If air has entered the cranial cavity, aeromedical evacuation must be accomplished at cabin altitudes maintained at as near sea level as possible.

Mandibular Fracture

Commonly, mandibular fractures are wired to stabilize the jaw. Should the patient become air-sick, he may be at risk for massive aspiration of vomitus. If aeromedical evacuation is anticipated, the patient's upper and lower jaws should be immobilized using elastic bands. An emergency release mechanism must be provided which can be activated by either the patient or the attendant. Unless the patient is Class IA or IB (psychiatric litter patients requiring restraints or tranquilizers) or under guard, he should have a pair of scissors attached to his person.

Evacuation Precedence and Classes

Patient precedence for aeromedical evacuation is classified into three groupings by OP-NAVINST 4430.9C: urgent, priority, and routine.

Urgent

Describes an emergency case which must be moved immediately in order to save his life, limb, eyesight, or prevent complication of serious illness. A special mission will be required to pick up the patient and deliver him to his destination medical facility. An aircraft already in the air may be diverted or an alert aircraft may be launched. By definition, psychiatric cases or terminal cases with very short life expectancy are not considered urgent.

Priority

For patients requiring prompt medical care not available locally. Such patients should be picked up within 24 hours and delivered with the least possible delay.

Routine

For patients who should be picked up within 72 hours and moved on routine scheduled flights.

Several classes of patients are detailed in OPNAVINST 4630.9C. These are summarized as follows:

1. Class 1 - Neuropsychiatric Patients

a. Class 1A. Severe psychiatric litter patients who require restraints, sedation, and close supervision at all times.

b. Class 1B. Intermediate severity psychiatric litter patients who are sedated but not restrained. Restraint equipment should be available if needed because patients may react badly to air travel or commit acts likely to endanger themselves or the aircraft safety.

c. Class 1C. Psychiatric walking patients of moderate severity, who are cooperative and proved reliable under observation.

2. Class 2. Litter patients other than psychiatric.

a. Class 2A. Immobile litter patients who are unable to move about on their own under any circumstances.

b. Class 2B. Mobile litter patients who are able to move on their volition in an emergency.

3. Class 3. Walking patients (other than psychiatric) who require medical treatment, care, assistance, or observation en route.

4. Class 4. Troop class walking patients (other than psychiatric) who require no medical treatment or observation during flight.

Evacuation Decision Consideration

The flight surgeon must account for many factors when making decisions regarding the evacuation of patients. The flight surgeon may be called upon to supervise the patient's care during initial aeromedical transportation to the carrier. It is important for the flight surgeon to be actively involved in patient care as early as possible. Requests for aeromedical consultation may be received by message, telephone, or radio from shore facilities, troops in the field, or from other ships. Flight surgeons are uniquely qualified to consider the many factors involved which include:

1. Diagnosis and prognosis of the patient.

Aeromedical Evacuation

2. Facilities available ashore.
3. Transportation modalities ashore.
4. Holding and transfer facilities available ashore.
5. Diplomatic and legal aspects.
6. Patient and crew safety in aeromedical evacuation.
7. Stretcher capabilities.

Diagnosis and Prognosis of the Patient

A patient who is going to die without neurosurgical intervention or one who will lose a limb without a vascular graft represent one extreme. The other is the patient with an undiagnosed illness which might reflect a normal variation (or might be fatal if not treated early.) Of paramount concern is the urgency of treatment, the uncertainty of diagnosis, and an estimate of the effects of treatment delay or deferral on the patient's prognosis.

Facilities Available Ashore

Flight surgeons and senior medical officers should be aware of hospital capabilities in their cruising area. The Air Operations Officer can supply lists with nearby airfields and their facilities. The Port Directory usually has a description of nearby hospitals. A list of U.S. military hospitals and facilities is generally available in foreign areas. Consular and embassy staffs can provide great assistance in determining local medical facilities and the diplomatic and administrative procedures required for admission of patients. Previous cruise reports also may be useful. Discussions with force medical officers may be informative. Planning for such eventualities should be included in preparations for deployments. Certain geographic locations and tactical scenarios may dictate prolonged stabilization and treatment aboard the carrier rather than transfer to inadequate facilities ashore. See Figure 16-1 for evacuation possibilities and modalities.

Transportation Modalities Ashore

Helicopter transfer to the selected hospital is the preferred method. Use of suitable ground or small ship alternatives may be required. Geographical considerations may require transportation via Carrier Onboard Delivery (COD) aircraft or air wing assets to a suitable airfield, with transfer to a hospital or awaiting Military Aircraft Command (MAC) aeromedical aircraft.

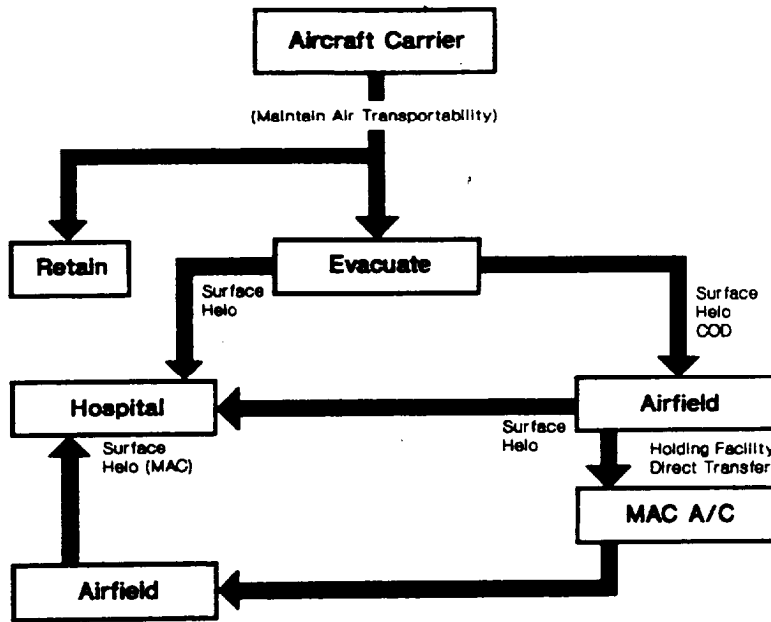

Figure 16-1. Evacuation possibilities and modalities.

Holding and Transfer Facilities

Patients may have to be held pending transfer to other means of transportation. Facilities for such transfer must be appropriate. This should be included in the aeromedical evacuation plan.

Diplomatic and Legal Factors

Diplomatic considerations must be entertained for the nation in which the hospital and any en route airfield are located. Diplomatic clearance or other administrative procedures may require delays that exceed time available.

Patient and Crew Safety in Aeromedical Evacuation

Safety of the crew of a helicopter or COD aircraft is a further consideration. *It is far better to keep a questionable case on board than to subject the patient, crew, and aircraft to a flight made unsafe by reason of inclement weather, crew fatigue, enemy action, or mechanical unreliability.* Aircrews often accept excess risk for medical evacuation missions. The flight surgeon must be aware of this when making evacuation decisions. He must consider the many facets of the pro-

Aeromedical Evacuation

blems mentioned here plus factors which will become apparent only on the scene and at the time. Each facet exerts its own influence as a determinant in the decision making process. Many aircraft and crews have been lost because they were launched on missions that proper prelaunch medical evaluation would have cancelled. The flight surgeon and senior medical officer must be integrated into the ship's command structure to ensure early notification and planning for medical evacuation eventualities.

Stretcher Capabilities

Three types of stretchers may be available on ships for medical use: Stokes (rigid), Neil-Robertson (semirigid), and the field (pole litter).

The Stokes Stretcher. The Stokes stretcher is a wire basket with a frame. It is contoured to give support to the occupant and to keep the frame between the patient and possible impacting objects. It has a wooden slat frame in the torso section, lines attached to the head and foot for lifting, and straps at the torso and midleg to restrain the patient. It is light, strong and usually readily available. Once a patient is properly placed on a Stokes litter, he can be transported directly to sickbay for care, carried to the flight deck, loaded aboard a helicopter and flown to more definitive medical treatment facilities, all without transferring him from the original stretcher.

The Neil-Robertson Stretcher. The Neil-Robertson semirigid stretcher is specifically designed to allow the patient to be packaged in the smallest possible volume. Thus he may be moved through restricted openings in the shipboard environment. Greater care must be utilized in transporting patients in the semirigid stretcher aboard ships because the stretcher offers minimal protection from aggravating existing or causing additional injuries during transport. The advantage of this stretcher is that it can be used in spaces where the Stokes rigid stretcher cannot be employed. It can also be lifted vertically in the escape trunk. It is the stretcher of choice in patient evacuation from or through confined spaces and restricted passages.

The Field Stretcher. The field stretcher or pole litter is carried aboard the ship primarily for use by the Marines and by landing parties. It occupies less floor space than the Stokes rigid litter and gives greater protection than a Neil-Robertson semirigid litter, However, it is inadequate for patient transportation from confined spaces. It is the required stretcher for MAC flights. It is the usual stretcher for helicopter medical evacuation flights. A Stokes litter is preferred if a patient will be catapulted from the carrier because of the additional protection from acceleration stresses. With the field stretcher, an air mattress must be used to give comfort comparable to that of a Stokes litter.

Aircraft Capability Considerations

The U.S. Navy and Marine Corps have no aircraft dedicated to aeromedical evacuation due to limited aircraft and flight deck capability. Instead, tactical aircraft must be diverted from operational assignments to perform aeromedical missions. This can pose significant problems and requires thoughtful interaction between the medical department, the receiving medical treatment facility, the air operations department, and other line organizations. Aboard the aircraft carrier, the senior flight surgeon should be intimately involved with all aeromedical evacuation operations from beginning to end. Aboard other aviation capable ships, the senior medical department representative or general medical officer should remain cognizant of medical evacuations. These represent high risk operations for the patient and other assets and demand thorough preparation.

Various military aircraft may be available for aeromedical evacuation. Fixed wing assets may include the C-130, C-9, C-141, C-5A, C-12, and P-3C. Helicopter assets may include the UH-1N, SH-2F, SH-3G, CH-46E, CH-53D, and SH-60B. However, capabilities and availabilities may vary considerably. Similar aircraft may have different capabilities due to installed equipment such as OMEGA navigation equipment, VHF communication radios, extended range fuel tanks, extended life rotor head bearings, etc. Such factors can mean the difference between success and failure for aeromedical evacuation missions. Flight surgeons must be aware of available aviation assets, their capabilities and procedures for obtaining those assets.

Aeromedical evacuation is undertaken to transport a patient to a more capable medical treatment facility, either afloat or ashore. Thus, patients may be transferred from destroyers and frigates to the aircraft carrier to utilize expanded diagnostic and treatment capabilities. Similarly, patients may be transported from the carrier to shore facilities for diagnostic and therapeutic reasons. Normally, the flight surgeon is concerned with forward, tactical, and certain intratheater aeromedical evacuations.

Military Airlift Command Aeromedical Evacuation System

A cost effectiveness study was completed following World War II which showed aeromedical evacuation was more beneficial to the patient than surface evacuation. It also saved attendant time and resulted in better utilization of crew members and trained medical personnel. The Secretary of Defense in 1949 directed that evacuation of sick and wounded military personnel would be accomplished by air in both peace and war. Hospital ships and surface transportation might be utilized if deemed necessary in unusual situations. That policy was formalized in OP-NAVINST 4630.9 series which limits aeromedical evacuation functions to units assigned to that mission. Local aviation assets may be used for aeromedical missions for medical urgent situa-

Aeromedical Evacuation

tions. The base commanding officer and medical officer must determine that utilizing routine aeromedical evacuation services is likely to endanger life, limb or cause a serious complications resulting in permanent loss of patient function.

Types of Aeromedical Evaluation Flights

OPNAVINST 4630.9 distinguishes various types of aeromedical evacuation flights based in part on origin and destination. Domestic aeromedical evacuation provides airlift for patients between points within CONUS and near offshore installations. Intertheater evacuation provides airlifts for patients between medical treatment facilities inside the combat zone and outside the combat zone. Forward aeromedical flights are limited to flights for patients between points within the battlefield and from the battlefield to the initial point of treatment and subsequent points of treatment within the combat zone. The Navy overseas commander is responsible for routes solely of interest to the Navy and Marine Corps when the Air Force cannot provide the services.

Aeromedical Evacuation Network

The Air Force Military Airlift Command (MAC) operates a world wide network of aeromedical flights and support facilities. The global system can be divided into three areas, each with its own command: the domestic system, the Pacific system, and the Atlantic system.

Domestic System. The domestic system supports CONUS, Caribbean and Northeast Atlantic, centered at Scott Air Force Base, Illinois. There are “trunk” and “feeder” lines to support the seven MAC aeromedical units: Scott AFB, Illinois; Lowry AFB, Colorado; Travis AFB, California; Kelly AFB, Texas; Maxwell AFB, Alabama; Andrews AFB, Maryland, and McGuire AFB, New Jersey.

Pacific System. The Pacific system operates from Hickam AFB, Hawaii and supports the Pacific fleet area.

Atlantic System. The Atlantic system operates from Rhein-Main AFB, Germany for flights in Europe and the Atlantic area.

Staging Facilities. At selected sites along the air evacuation routes are Aeromedical Staging Facilities. The medical facilities provide reception, processing, ground transportation, feeding, and limited medical care for patients entering, en route, or leaving the aeromedical evacuation system. Similar in function, but more highly mobile are the Mobile Aeromedical Staging Facilities for use in combat zones.

Criteria for Aeromedical Evacuation

As much as possible, MAC will meet the following criteria in providing aeromedical evacuation services:

1. Movement of patients within CONUS shall be no later than 36 hours after arrival.
2. Patients shall be delivered to their destination within 72 hours after entry into the domestic system.
3. There shall be an average of not more than one overnight (RON) stop between entry into the domestic system and delivery at the destination.
4. An RON stop shall not exceed 36 hours.
5. Time in transit shall not exceed 18 hours prior to an RON stop for rest and recuperation.

Humanitarian Aeromedical Evacuation

For purposes of air transportation eligibility, DOD regulation 4515.13R divides patients into U.S. armed forces and non-U.S. armed forces categories. U.S. armed forces patients are by definition active duty or eligible retired members of the armed forces, dependents of eligible active duty service members or retired members under provision of SECNAVINST 6320.8, or U.S. citizen civilian employees of the Department of Defense and their lawful dependents when stationed outside CONUS.

Emergency lifesaving aeromedical transportation is authorized for non- U.S. armed forces patients satisfying the following criteria.

1. The patient's illness or injury is an immediate threat to life.
2. The medical capabilities in the patient's immediate geographical area are not adequate for diagnosis and treatment under generally accepted medical standards. In these cases, transportation will be furnished only to a medical treatment facility which can provide the necessary treatment.
3. Suitable commercial transportation is not available. Non-U.S. armed forces patients will not be accepted for movement if their condition is terminal or if the only reason to request military

Aeromedical Evacuation

transportation is lack of personal funds, personal or family convenience, or medical experimentation (unless competent medical authority determines that such experimentation will save a life).

Patient Preparation

Proper patient preparation is critical. Well thought out medical evacuation preparations will reduce morbidity and mortality. A five minute helicopter flight to a nearby medical facility may require limited planning and preparations. Major planning is required for an aeromedical evacuation that includes a long helicopter flight to meet with a MAC aeromedical evacuation airplane at a foreign airport with further transport to a distant tertiary care hospital. It is probably better to over plan such activities than to have problems during the transport. Patient preparations include the following:

1. Brief the Patient

The patient should be briefed regarding his medical condition, medications, emergency procedures and prognosis. He should be familiar with the aeromedical system, routing, baggage limitations, need for personal funds, appropriate uniform, destination hospital, and any other, information.

2. Patient Medical Treatment Records

The patient's medical records, narrative summary and other medical information should be included. Prudence requires making copies of this information prior to transfer. Sending patients with inadequate medical documentation does a disservice to the patient and the receiving treatment facility. Do not neglect to send X-rays.

3. Patient Personal Records

The patient must carry his military identification card and official orders. Personnel records, baggage, and other personal items may have to be gathered and sent along with the patient.

4. Medical Support Equipment, Supplies, and Medication

Sufficient medical support equipment, supplies, and medication for five days should accompany the patient. All drugs should have the name, strength, dosage, or prescription affixed. Extra batteries, bandages, IV fluid and tubing, or other needed items should be included, particularly for a complicated transfer. Reliance on other sources of medical equipment is fraught with pro-

blems. A fly-away medical kit should be maintained by the medical department since rapid response may be required.

5. Medical Readiness for Transfer

Ensure Maximal Medical Readiness for Transfer.

- a. Give preflight medications as needed.
- b. Transfuse patients with hematocrit less than 30 per cent. Give IV fluids when required as close to departure time as possible, with access maintained as appropriate.
- c. Apply indwelling catheters in cases requiring frequent catheterization. Supply irrigation solution if required.
- d. Apply clean dressings as near the time of departure as possible, particularly for colostomies, draining wounds, burns, and pressure sores. Ensure that adequate dressing supplies accompany the patient.
- e. For patients with mandibular fractures, immobilize upper and lower jaws with elastic bands rather than wire, and provide an emergency release mechanism. For a patient with immobilized jaws, ensure that a pair of scissors is attached to his person unless he is a Class 1A or 1B patient or under guard.
- f. Bivalve all casts which are applied within 24 hours of departure.
- g. Sedate neuropsychiatric Class 1A or 1B patients and deliver them to the aircraft in a litter dressed in pajamas.
- h. Apply restraints to all Class 1A patients and to any Class 1B patients who are combative, suicidal, violent, or considered doubtful.

6. Medical Attendant

The patient should be accompanied by appropriate medical personnel. This may include a medical officer or corpsman. The needs of the patient must be balanced against the operational needs of the ship or unit. The attendant must have appropriate orders (with TANGO numbers), funding, uniforms, civilian clothes, passports, medical equipment, medications, or other necessary items.

7. Follow-up

The ship's medical department should follow up the medical evacuation. The status of the patient should be monitored throughout the transport and thereafter. The medical department, the patient's command, and his shipmates have an interest in him and his welfare. Requests for updates via message may be considered at ten day intervals after transfer.

Bibliography

American College of Surgeons. *Advanced trauma life support*. Chicago, IL: American Medical Association, 1989.

American Heart Association. *Advanced cardiac life support*. Dallas, TX: American Medical Association, 1988.

AMA Commission on Emergency Medical Services. Medical aspects of transportation aboard commercial aircraft. *Journal of the American Medical Association*, 1982, 247, 1007-1011.

Baird, R.E., McAnch, G.W., & Ungersma, J.A. High altitude penetrating chest trauma. *Military Medicine*, 1981, 191, p.337.

Johnson, A. A treatise on aeromedical evacuation. *Aviation, Space, and Environmental Medicine*, 1977, 48, 550-554.

McLennan, J. & Ungersma, J.A. Pneumothorax complicating fracture of the scapula. *Journal of Bone and Joint Surgery*. 1982, 64, 598-599.

McNeil, E.L. *Airborne care of the ill and injured*. New York: Springer-Verlag, 1983.

Tension pneumopericardium following penetrating chest injury. *Journal of Trauma*, 1987, 27, 800-808.

APPENDIX 16-A

CHECKLIST FOR AEROMEDICAL EVACUATION PROCEDURES

1. Evaluate the patient and the situation.
 - a. Is the patient stable enough to be transported?
 - b. How soon should the patient be transported?
 - c. Are medical evacuation assets available to pick up the patient and deliver him to adequate facilities?
2. Notify the ship's captain of the need for medical evacuation.
 - a. This is a recommendation, the captain may decide against evacuation for reasons known only to himself. Ship's company and air assets will be as supportive as possible.
 - b. Coordinate with accepting facility and transporting agency.
3. Provide for medical needs for evacuation.
 - a. Assure sufficient equipment, supplies, and medications are available for medical evacuation (e.g., oxygen, IV fluids and tubing, splints, blankets, helmets, cranials, flotation devices). A fly-away bag should be maintained with common requirements, medications and equipment for delays enroute.
 - b. Label each medical container with name, rank or rate, SSN, generic name, dosage rate, and date.
 - c. Provide clear instructions for medications, equipments, and supplies.
4. Ensure that manifest and personal identification requirements are met.
 - a. Provide manifest as per BUMEDINST 4650.2A DD form 601.
 - b. Ensure patient identification per BUMEDINST 4650.1A DD form 602.

Aeromedical Evacuation

c. Courtesy suggests a list of all patients in the flight should be sent to the accepting facility's senior medical officer. The list should include name, rank or rate, SSN, diagnosis, medications and special requirements.

5. Ensure that record requirements are met. Records should be enclosed in a large, sealed manila envelope clearly labeled with name, rank or rate, SSN, destination, and diagnosis.

a. Health record, including outpatient, inpatient with completed narrative summary describing problems (history, physical examination, laboratory, medications, and plan). A copy of appropriate records should be maintained if possible.

b. Dental records.

c. Pay records, service record book, etc.

d. Passport, official orders with TANGO number, etc.

6. Prepare medevac crew.

a. Advise the pilot or HAC of the patient's condition. Make recommendations about flight altitude, pressurization requirements, equipment requirements, duration of expendables, handling of emergencies, etc. Request that the pilot or HAC notify the receiving authority 5 to 10 minutes prior to arrival. Inform the pilot or HAC to expect updates on the medical condition periodically during the flight.

b. Brief aircrewmen on the status of the patient and the need to make regular reports to the pilot or HAC on the patient's status. He also should be made aware of the patient's special needs.

c. Prepare the medical attendant. He must know the diagnosis, medications and their administration, and how to use equipment and supplies. The medical attendant must also have appropriate clothes, ditty bag, official orders (including TANGO number), passport, money, credit cards, etc.

7. Brief the patient.

a. Medical conditions, requirements for transfer, anticipated flight conditions, duration of flight, destination.

U.S. Naval Flight Surgeon's Manual

- b. Emergency escape procedures.
 - c. Special equipment utilization and function.
8. Notify the receiving medical authority before the flight departs.
- a. Name, rank or rate, and SSN of patient.
 - b. Diagnosis, symptoms, and reason for transfer.
 - c. Equipment, medication, and supplies.
 - d. Destination and ETA.

CHAPTER 17

MEDICATION AND FLIGHT

Introduction
Objectives
Effects of Drugs
Present Drug Usage
Specific Drugs
Alcohol
Drugs in Nonpilot Populations
Summary
References and Bibliography

Introduction

Medication can kill. For this reason, it is of paramount importance for the flight surgeon to be aware of any drugs an aviator under his care may be taking. This may be difficult to do because of the ready availability of sinus medications, cold preparations, sleeping pills, and a variety of other “over-the-counter” medicines at most drugstores, some grocery markets, and also at the Navy Exchange. With the increasing medical sophistication of the general public through radio and television advertising and through articles in popular magazines, there is a definite possibility of self-diagnosis and self-prescription.

Authority for recommending the grounding of aviators taking medications comes from several sources. The *Manual of the Medical Department* (NAVMED 117) recommends that persons requiring therapeutics be found not fit for flying. Further, Chapter 15, Article 78 orders that “All aviation personnel admitted to the sick list or hospitalized shall be suspended from all duty involving flying.” Chapter 7 of the *NATOPS General Flight and Operating Instructions Manual* (OPNAVINST 3710.7 series) states that the naval flight surgeon should indicate the necessary flight limitations on all prescriptions for flight personnel.

If only flight surgeons treated flying personnel, there would be fewer problems. However, it is important to remember that flying personnel may be treated by *any* physician, whether civilian or military, and whether in the flight surgeon’s office, the emergency room, or in an outpatient

clinic. This situation poses two problems. Frequently non-flight surgeon physicians are unaware of the hazards associated with taking medications while flying. Thus, they will fail to warn the aviator of the dangers, fail to ground him, and fail to label the prescriptions with appropriate warnings. A second and related hazard is that all the medication may not be used up with the initial illness, but may be saved and used for another illness. By then the aviator may have forgotten the need to restrict his flying. To help prevent this, it may be helpful to flag an aviator's medical record with a brightly colored instruction sheet warning non-flight surgeons to ground the aviator until he can be seen by a flight surgeon.

The proper course is to ground flying personnel until their illness and their need for medication have passed. Any physician may recommend grounding of flying personnel. Only a flight surgeon can recommend clearance to fly. This authority is in recognition of the flight surgeon's special concern for flying safety and his special training toward that end. It imposes upon him a corresponding special responsibility which should not be undertaken lightly.

Objectives

The basic objective of a flight surgeon is safety of flight. By his decisions, a flight surgeon is directly responsible for saving both lives and costly aircraft. This is not only preventive medicine, but also cost-effective industrial safety being practiced at a very personal, physician-patient relationship level.

Ideally, preventive medicine should be practiced so that flying personnel are kept healthy and have no need for medication. However, when drugs do become necessary, they should be selected so as to produce, if possible, a fast, permanent cure, do no harm, and have the fewest possible side effects. The benefits of this approach for the patient are to keep him comfortable during the healing process, to restore him to health, and to preserve and prolong his career. The benefits for the Navy derive from the cost savings effected by preventing the loss of expensive aircraft, by prolonging the careers of valuable, expensively trained, flying personnel, and by keeping effective and on-the-job key personnel directly responsible for accomplishing the Navy mission.

Effects of Drugs

Perhaps the most important factor to be considered when deciding whether to ground an aviator for taking medication is not the medication itself, but rather the disease for which the medication was prescribed. Normally, any illness significant enough to bring flying personnel to the flight surgeon or to prompt the flight surgeon to prescribe drugs is sufficient in and of itself to warrant consideration of grounding the aviator. If either the disease or the drug has effects or side

Medication and Flight

effects which would impair the physical, mental, or emotional functioning of the individual, then grounding should be considered.

In deciding whether to ground an aviator taking medication, it is important to analyze the effects of the drug, and then relate these effects to the mission and to the individual's role in the mission. For instance, gastroenteritis in a radar operator aboard a large patrol aircraft could be handled in a much different way from the same disease in the pilot of a single-seat fighter aircraft. In the latter instance the disease alone might ground the pilot. When the effects of the drug compromise an individual's ability to perform *effectively and safely*, and when they decrease his ability to withstand the stresses of flight or of a survival situation, grounding of the aviator should be considered. On the other hand, when prior testing has shown the drug to accomplish its purpose and to produce no adverse side effects, the flight surgeon may decide to prescribe the drug for use in flight when it is necessary for accomplishment of a mission. Such an example might be the prescribing of antimotion sickness drugs for student pilots, accompanied by an instructor, for their first few flights or for their first acrobatic flights.

In analyzing whether to allow an aviator to use drugs in flight, all effects of the drugs should be considered. Many drugs have more than one effect - some are desirable and intended, and others are unwanted side effects. The latter are further subdivided into *predictable* physiological responses, *unpredictable* physiological responses, and *idiosyncratic* reactions. Examples of drugs which might demonstrate these side effects are atropine and other anticholinergics. The intended physiological response might be suppression of acid production or gastrointestinal motility. A predictable, unwanted side effect might be pupillary dilation and decreased accommodation. An unpredictable, unwanted physiological side effect might be the degree to which an individual's heart rate response to the G-forces of flight is compromised. An idiosyncratic reaction might be a rash or precipitation of glaucoma. Other drugs should be analyzed similarly.

Basic to the analysis of a drug's applicability in flying personnel is the requirement that the physician know *all* the effects and side effects of the drug (even if this requires going back to the books to find them). Information on the side effects of drugs is available from many sources. One which is useful is *Guide to Drug Hazards in Aviation Medicine* written by W.C. Cutting, M.D., for the Federal Aviation Administration. It is available through the Superintendent of Documents, U.S. Government Printing Office, Washington, D.C. 20402. The flight surgeon must then analyze those actions as they relate to aviation safety. The following listing gives some of the factors to be considered.

Interference With Normal Bodily Functions

1. Vision - Does the medicine cause pupillary dilation or photophobia? Does it decrease accommodation and cause blurring of vision or decreased visual acuity, etc.?

2. Cerebration - Does the medicine produce drowsiness, confusion, illusions, hallucinations, disorientation, psychosis, etc.?

3. Blood pressure, pulse rate, vascular tone, and myocardial contractility - Does the medicine affect any of these factors in such a way as to cause hypotension, significant hypertension, arrhythmias, or alter the body's normal reaction to stress?

4. Temperature control - Does the drug affect the central thermal regulatory centers or the peripheral mechanisms (sweating, vasodilation, etc.) involved in temperature control? How will this affect an aviator if he is sitting in a cockpit which has a "greenhouse effect," or if he is down at sea in cold water?

5. Oxygenation - Does the drug affect the rate or depth of respiration? Does it alter the chemical ability of the blood to become oxygenated or to release oxygen to the tissues? Will the drug cause anemia, etc.?

6. Comfort - Will the drug cause distracting, uncomfortable side effects such as dry mouth, itching, flushing, etc.?

7. Gastrointestinal function - Does the drug cause nausea, stomach cramps, diarrhea, constipation, etc.? Will it interfere with motility and cause trapped-gas problems?

8. Vestibular System - Does the drug cause vertigo, or decrease the individual's threshold for motion sickness? Will it in any way increase his susceptibility to disorientation?

9. Homeostasis - Does the drug cause chemical derangement of the body? Does it alter the body's capacity to respond to changes in fluid intake, etc.?

10. Musculoskeletal - Does the drug limit the motion of any extremity or of the spine? Does it cause unwanted, involuntary movements?

Medication and Flight

Ability to Withstand Stress

1. Hemorrhage - Does the drug cause bleeding? Will it adversely affect the body's ability to cope with bleeding if injuries are sustained?
2. G-forces - Will the drug decrease the aviator's ability to cope with G-forces during the aircraft maneuvering or ejection?
3. Heat - Will the drug predispose to heat stroke? What will its effect be on the aviator waiting at the end of the runway for takeoff in a cockpit with a "greenhouse" effect?
4. Dehydration - Does the drug cause diuresis, decrease fluid intake, increase insensible fluid loss or sweating?
5. Survival situation - Will the drug decrease an aviator's chances of survival in case of a crash or ejection? Does it sensitize the myocardium to arrhythmias with exposure to cold water? Will he be able to survive without injury in a survival situation if he does not take the medicine?
6. Change in barometric pressure - Does the drug cause mucosal swelling which might block the sinus ostia or the eustachian tubes? Does it delay gas transport in the intestines and lead to trapped-gas problems, etc.?
7. Hypoxia - Does the drug tend to cause hypoxia? Does it change the body's response to hypoxia? Does it obscure the pilot's ability to recognize hypoxia? Does the action of the drug change in the presence of hypoxia, etc.?

Risk of Incapacitation

1. Sudden - What are the chances that the disease will cause sudden incapacitation? If the disease doesn't, could the drug suddenly render an aviator incapable of performing his duties? Could it cause unconsciousness, severe pain, tetany, vertigo, decreased visual acuity, etc.? Any drug or disease which could cause interference with an aviator's ability to function effectively should be considered a cause for grounding.
2. Insidious - Insidious incapacitation is sometimes much harder to identify or to predict than is sudden incapacitation and is thus much more dangerous. The pilot who gets vertigo and faints due to orthostatic hypotension as a side effect of a drug will probably ground himself. However, the same pilot taking a sleeping pill because of domestic problems may not even recognize the

decrement in his performance which persists for hours the next day, even after the obvious soporific drug action has worn off.

Insidious incapacitation is an even greater problem when a drug will be used over a period of several days, weeks, or even longer. Problems such as potassium depletion from some diuretics may not manifest themselves until the patient has been on the drug for a long period of time. Even then, an additional stress, such as dehydration, may be necessary to make the condition manifest. The time interval from an aviator's starting a drug until he could be considered safe to fly, must be long enough for any cumulative effects to manifest themselves. It must also be long enough for an aviator to experience all the side effects of the drug and to learn to recognize those side effects.

Modification of Drug Action Due to Flying

The flight surgeon must consider all the stresses imposed on an aviator by flying and how these stresses will interact with the effects and side effects of the drug. As an example, hypoxia is dangerous enough by itself. A borderline case of hypoxia, that might not have resulted in fatality, might be converted into a sudden catastrophe if an aviator is taking systemic decongestants or using nasal spray for a cold. Adrenergic drugs and sympathomimetics sensitize the myocardium to the effects of hypoxia and can cause dangerous, suddenly incapacitating cardiac arrhythmias. Another example is the lack of alertness which can result from the additive effects of fatigue and drowsiness from antihistamines. Many similar examples will be apparent to the concerned Flight Surgeon.

Present Drug Usage

The number of medications authorized for use without a waiver has increased in the past years as clinical experience has increased. Birth control pills may be used without waiver if the aviator is stable after three cycles and is without side effects but use should be mentioned on each flight physical. Topical nasal steroids are allowed in many instances without waivers. Antimalarials are approved if there are no adverse side effects. Low dose erythromycin and tetracycline for acne are approved although it should be documented on physical examinations. Hydrochlorothiazid is the only antihypertensive so far approved for use without waivers as long as it is used in low doses. However, the aviator is grounded when treatment starts and is kept in a grounded status for 2 weeks after the dose is stable. A new physical should be forwarded to Naval Aerospace Medical Institute (NAMI) Code 42 upon initiation of this therapy. Captopril and Enalapril are permissible but their doses are restricted and a waiver is required. INH for TB prophylaxis is acceptable without waiver provided close evaluation is maintained by the Flight Surgeon. Other long-term

Medication and Flight

medications may be considered for waivers on an individual basis by submitting a request for waiver through NAMI Code 42.

Specific Drugs

Antibiotics

Antibiotics which can be prescribed for use by an outpatient are multiple, and the chance that aviators will need them is always present. In addition to individual specific side effects, some general side effects or reactions deserve comment.

1. Allergic reactions to antibiotics, especially penicillin, are not infrequent. Immediate, sudden incapacitation may occur with anaphylaxis, angioneurotic edema, or asthma. Less dramatic but still potentially dangerous skin rashes, photosensitivity reactions and urticaria occur with regularity.

2. Bone marrow toxicity develops with some antibiotics, notably chloramphenicol. The resulting anemia or decreased resistance to infection poses a risk for aviation duties since it may be present for some time before being diagnosed.

3. Ototoxicity occurs primarily with the polypeptide group of antibiotics which are ordinarily reserved for more severe infections. Nevertheless, aviators will receive them occasionally. Either hearing loss or disequilibrium may result and disable an aviator.

4. Other possible side effects are multiple and require consideration.

Nonnarcotic Analgesics

Two general types of analgesics are in common usage, the salicylates and the aniline derivatives. They are commonly available under names such as aspirin, APC's, Bromo-Seltzer, Alka-Seltzer, Tylenol, etc. Due to their extremely common use, there is a tendency to forget that they do have adverse effects. Among these are gastritis, tinnitus, loss of hearing, and methemoglobinemia.

Sulfonamides

Sulfonamides are frequently used for treatment of urinary tract infections. Among their adverse effects are methemoglobinemia, decreased depth perception, accentuation of phorias, nausea, vomiting, dizziness, dermatitis, agranulocytosis, and hepatitis.

Topical Medications

In general, most topical preparations are safe to use with flying. However, some ointments that are petroleum based may oxidize rapidly in the 100 percent oxygen environment of an aviator's mask and probably should not be used around the face.

Alcohol

Alcohol is a drug, but, due to its wide social use, there is a tendency to forget that and regard it only as a beverage. Aviators are specifically prohibited from flying within twelve hours of last consuming alcohol (OPNAVINST 3710.7 series). The acute toxic effects of central nervous system depression, uncoordination, and altered judgment are well known, but other effects of alcohol are sometimes forgotten. These include diuresis, gastritis, myopathies (and especially the direct effect on heart enzymes producing cardiomyopathy), hepatic damage, peripheral neuropathies, and long-term central nervous system complications (delerium tremens, cerebral atrophy, psychoses). Alcohol affects multiple body systems adversely.

For more extensive coverage, see Chapter 18, Alcohol Abuse

Drugs in Nonpilot Populations

Crew Members

Most of the preceding comments apply equally well to nonpilot crew members and to pilots. In some cases, different standards may be used to judge fitness to fly, and it is up to the individual flight surgeon to exercise his best judgment in making exceptions.

Medevacs and Passengers

Since passengers on routine flights and patients on Medevac flights are not primarily responsible for the safety of the flight or the completion of the mission, different standards apply in deciding whether to allow them to fly when using drugs. Basically, the consideration is whether or not it is safe to fly when taking a particular medication. Again, the basic disease for which the drug is taken should be considered first. Then the effects of the drug should be assessed in relation to the particulars of that flight (type aircraft, altitude, oxygen equipment aboard, etc.).

A word is in order about certain drugs. Sedation and pain relief are frequently necessary on Medevac flights. Although most Medevac flights are in pressurized aircraft with oxygen equip-

Medication and Flight

ment aboard, the potential for respiratory depression and resultant hypoxia should be considered in patients for whom narcotics, barbituates, or chloral hydrate are prescribed. The possibility of loss of pressurization or other emergency cannot be dismissed. Chloral hydrate, in addition, has the potential for cardiac depression. Paraldehyde is probably the safest sedative for in-flight use, but has the disadvantage of a very prominent odor which might aggravate the tendency to motion sickness of other persons in the airplane. Flurazepam and diazepam appear to cause less respiratory depression at effective doses than do other hypnotics and tranquilizers. Belladonna alkaloids and other parasympathetic depressants are in frequent use for peptic ulcer disease. However, they may contribute to trapped-gas problems.

Summary

When considering whether an aviator should or should not fly when taking drugs, the general medical condition of the patient should always be the first and overriding concern of the flight surgeon. Then the effects and side effects of the drug should be considered as they interrelate with the requirements and stresses of flying.

If a pilot must fly, then the flight surgeon should discuss, with both the aviator and his commanding officer, the interference with the accomplishment of the mission which may be attributable to the disease and the drug. He must provide them with the factual basis to decide whether the mission is more important than the safety of the pilot or the plane, and whether the pilot can accomplish the mission. It is in the flight surgeon's duty to make flight more effective and safe. He must determine an aviator's fitness to fly. The commanding officer must determine the need to fly.

References and Bibliography

- Cutting, W.C. *Guide to drug hazards in aviation medicine*. Federal Aviation Administration, Aviation Medical Service. Washington, D.C.: U.S. Government Printing Office, 1962.
- Department of the Navy. *Manual of the Medical Department, U.S. Navy* (NAVMED117). Washington, D.C.: U.S. Government Printing Office.
- Department of the Navy. *NATOPS General flight and operating instructions* (OPNAV Instruction 3710.7 Series). Washington, D.C.: U.S. Government Printing Office.
- Goodman, L.S., & Gilman, A. (Eds.) *The pharmacological basis of therapeutics* (7th ed.). New York: MacMillan, 1985.
- Physician's desk reference*. Oradell, N. J.: Medical Economics Co., 1989.

CHAPTER 18

ALCOHOL ABUSE AND ALCOHOLISM

Introduction to Alcohol Abuse and Dependence
Definition of Alcoholism
Alcohol Related Syndromes as Defined by DSM-III-R
Diagnosis of Alcoholism
Confrontation and Intervention Techniques
Rehabilitation Programs
Follow-up Disposition and Management of the Recovered Alcoholic
Comments on Detoxification
Summary
References and Bibliography
Acknowledgment

Introduction to Alcohol Abuse and Dependence

Alcohol abuse and dependence remain one of the most common, controversial, and emotionally laden topics that the flight surgeon must deal with. The cost to the Navy and society in lives, dollars, and time, is staggering. Each flight surgeon is encouraged to become an expert in recognition and management.

The association of alcoholic beverages and the maritime services are as old as history itself. Consequently, it is of no surprise that the abuse of alcohol and alcoholism among members of the naval aviation community is as old as aviation itself. Only within the last decade has alcohol abuse in naval aviation been openly discussed or scientifically studied. This omission was primarily due to two factors:

1. The stigma of alcoholism has long been considered a moral weakness (incompatible with the heavy drinking, "macho" image of the "scarf in the wind" aviator).
2. The traditional handling of alcohol problems through administrative and punitive channels leading to ruined careers and often to loss of retirement pay hampered identification or self-reporting of alcohol difficulties.

U.S. Naval Flight Surgeon's Manual

In spite of significant educational campaigns by the Department of the Navy and advances in alcohol treatment, heavy drinking and frequent drinking continue to be a significant part of our lifestyle, both in the civilian sector of our country as well as in naval aviation as a subculture. From a psychological standpoint, we use alcohol to control almost any shift in our emotions or to set the tone for any emotional change we are seeking to achieve. The intended chemical effect can be myriad: stimulant, antidepressant, sedative, analgesic, tranquilizer, aphrodisiac, or soporific.

Traditionally, in naval aviation, we drink at happy hour, after a good flight, after a bad flight, and after a near midair collision (to calm our nerves). We use it to celebrate our first solo flight, and we traditionally present our instructor with a bottle of his favorite liquor. We drink when we get our wings, we drink when we get promoted (wetting-down party), when we get passed over (to alleviate our depression), at formal dining-ins, changes-of-command, chiefs' initiations, and at "beef and burgandy night." At birthday balls, we drink the door prize if we have the lucky ticket.

In light of this continued social acceptance and availability, it is no surprise that alcohol continues to be a primary source of morbidity and social dysfunction in the Navy in general, and specifically, in naval aviation.

Alcohol has a direct impact on the aviation community in several specific ways:

1. Acute intoxication (or even minimal "social" use) shortly before or during flight operations or before performing equipment maintenance work, absolutely hampers performance because of the effect on judgment and neuromuscular coordination. A recent study of pilot's performance suggest that impairment after intoxication may last longer than fourteen hours (Yesavage & Leirer, 1986).
2. Hangover symptoms of headache, fatigue, nausea, irritability, impaired judgment, and impaired neuromuscular coordination interfere with normal workday efficiency.
3. Chronic use of alcohol over a period of months or years will lead to true physically dependent alcoholism which can be considered a fatal illness.
4. The effects of repeated alcohol abuse on the family, friends, and acquaintances of the afflicted individual are routinely catastrophic.
5. Administrative difficulties, including disciplinary problems, medical problems, absenteeism, and material damage, are often a direct result of alcohol use.

Alcohol Abuse and Alcoholism

The potential dangers (listed below) frequently become a reality because certain aspects of the problem are either not generally known or, if suspected, are ignored by medical as well as line officers in the aviation community:

1. Alcohol is a drug belonging to the sedative, hypnotic group. It acts as a depressant and an anesthetic with a subsequent "hangover" and a rebound period of irritability or agitation in anyone who drinks (social drinker or chronic alcoholic alike). Forty percent of "heavy drinkers" eventually become alcoholics.
2. Alcoholism is a disease which affects not only those who have it, but it also has a pronounced and deteriorating psychological, social, economic, and physiological effect on the family and friends of the alcoholic. The adult child of the alcoholic syndrome is becoming more and more a definable entity and itself may warrant treatment (Woititz, 1983).

Definition of Alcoholism

Of the many definitions given, the common denominator is that alcoholism exists in a person when alcohol use and damage to the person's life by alcohol coexist. The World Health Organization definition is as follows: "Alcoholics are those excessive drinkers whose dependence upon alcohol has reached such a degree that it results in noticeable mental disturbance or in an interference with their bodily and mental health, their interpersonal relations, their smooth social and economic functioning, or those who show the signs of such developments." The American Medical Association defines alcoholism as an illness characterized by significant impairment of physiological, psychological or social functioning that is directly associated with persistent and excessive alcohol use.

In the Navy alcohol prevention program, the following workable definition is used as an indicator that the person in question has developed alcoholism, or is close to developing it and needs a careful examination to determine the extent of his alcohol problem and to prevent further deterioration. The Navy definition states "an alcoholic" is anybody whose drinking has seriously begin to interfere with one or more of the following aspects of his life:

1. Family life
2. Social life
3. Legal life
4. Financial life
5. Physical life

6. Mental life
7. Spiritual life
8. Occupational life.

The *Diagnostic and Statistical Manual of the American Psychiatric Association* uses objective criteria for diagnosis of alcohol abuse and alcohol dependence (alcoholism). In *DSM-III-R*, these two conditions are considered separately. Most cases classified as alcohol abuse in *DSM-III* are now in the *DSM-III-R* category of alcohol dependence. In *DSM-III-R*, released in July of 1987, physical dependence or withdrawal is not necessary for the diagnosis of alcoholism. *DSM-III-R* code number 303.90 criteria for alcohol dependence should include at least three of the following:

1. Substance taken in larger amounts or over a longer period than intended.
2. Persistent desire or efforts to control or cut down use.
3. Increased time in substance seeking or recovery from use behavior.
4. Frequent intoxication or withdrawal that interferes with major role obligations.
5. Important life activities given up or reduced because of substance use.
6. Continued use despite knowledge of recurrent problems.
7. Marked tolerance.
8. Characteristic withdrawal symptoms.
9. Substance taken to relieve or avoid withdrawal.

It will be continually reiterated that the fine line between alcohol abuse and alcohol dependence (alcoholism) is blurred and often judgmental or circumstantial. Often it is much more prudent to classify a diagnosis as alcohol dependence and afford the individual the best chance at rehabilitation, as well as recovery and preservation of life, family, and career.

Alcohol Related Syndromes as Defined by DSM-III-R

Simple Drunkenness (Alcohol Intoxication, Code 303.00)

Blood Alcohol Levels (BAL) commonly used as guides to impairment:

- 1 - 0.05% - exhilaration - loss of inhibitions.
- 2 - 0.11% - slurred speech and staggering gait.
- 3 - 0.20% - euphoria - marked gait impairment.
- 4 - 0.30% - confusion.
- 5 - 0.40% - stupor.
- 6 - 0.50% - coma.
- 7 - 0.60% - respiratory paralysis and death.

Pathological Intoxication (Alcohol Idiosyncratic Intoxication, Code 291.40)

1. Intoxication with small amounts of alcohol (usually less than four ounces).
2. Manifest aggressive or assaultive behavior.
3. This behavior is followed by sleep or amnesia for the event.

Alcohol Withdrawal Syndrome (Delirium Tremens, Code 291.00)

1. Three to five years heavy drinking followed by a sudden drop in blood alcohol concentration.
2. Prodrome (nightmares, irritability, anxiety).
3. Symptom triad:
 - a. Mental confusion.
 - b. Tremors (hyperactivity, increase of vital signs).
 - c. Hallucinations (usually visual).
4. Symptoms last three to ten days; 10 percent fatality rate if untreated.
5. Comparison of early and late withdrawal:

Early Withdrawal Symptoms

8-9 hours after last drink
Sweating, flushed face, insomnia
Hallucinations (25 percent)

Grand mal seizures (Rum fits)
Mild or no disorientation

Late Withdrawal Symptoms

Delirium Tremens
Starts 48-96 hours after last drink
Tremor, increased psychomotor activity
Vivid hallucinations
No seizures
Profound disorientation
Increased autonomic activity with fever.

Alcohol Hallucinosi s, Acute (Code 291.30)

1. No disorientation or tremor.
2. Hallucinations, usually auditory and of a paranoid nature.
3. Occurs without a drop in blood alcohol concentration and while the patient is drinking.
4. May be due to a latent schizophrenic process for which the patient was self-medicating with alcohol.

Alcohol Amnestic Disorder (Alcoholic Blackouts; Code 327.04)

Dementia Associated With Alcoholism (291.2x Coded as (a) Mild, (b) Moderate, or (c) Severe).

Diagnosis of Alcoholism

Medical History

Unlike the history taken in most other disease entities, the historical information on alcoholism often has to be obtained from more than one source. The examiner has to fit together various pieces of information from differing sources in order to clearly visualize the extent of the disease process in the patient. Sometimes the history, as given by the patient himself, is inadequate and often misleading. More often, the information is absolutely incorrect because the patient is using the psychological defense of denial, which is a primary symptom of alcoholism. In obtaining the history, the flight surgeon should keep in mind the previous list of the eight areas of a person's functioning. Specific elucidation of current functioning in those areas should be ascertained, and the interview should be directed at establishing a relationship between alcohol use and the deterioration in one or more areas of the patient's lifestyle.

Historical information should be obtained from the patient's spouse, friends, superiors, or significant others who are familiar with the patient's daily living habits and work performance. When the patient is seen in the emergency room, supplemental information can often be obtained from those who brought him to the emergency room, including cab drivers, policemen, or friends. In addition to determining the extent of destruction which is taking place in the patient's life, the flight surgeon should try to establish whether or not the patient has experienced alcohol tolerance or withdrawal now or in the past. Questions about tolerance are often better addressed to the family and to friends or those who are familiar with his drinking habits. If the patient is far

Alcohol Abuse and Alcoholism

advanced into alcoholism or if he is trying to deny his illness, he will often minimize the amount of alcohol he actually consumes on a daily basis.

The flight surgeon is in an ideal position to make the diagnosis of alcoholism because he not only knows the patient's family, friends, and superiors from his squadron interaction but also has access to the patient's health record and service record. Both of these documents can be very useful supplements in the history taking process.

The health record may indicate the frequency and nature of sick calls, including hospitalization and injuries. In reviewing the health record, one should pay particular attention to time and frequency patterns of injuries and illness particularly during and after holidays, weekends, or Monday mornings. Unexplained injuries, bruises, contusions, and episodes of gastritis or GI upsets are particularly valuable indicators. Attention should be paid to psychiatric consultation, notes of injury to family members, depressive reactions, or any history of family discord.

The patient's service record can also supply further information about the alcoholic's deterioration by shedding light on such things as letters of indebtedness, letters of reprimand, humanitarian transfer, or having to be Medically Evacuated from an overseas billet.

Physical Findings

The physical findings in the early stages of alcoholism or alcohol abuse may be nonexistent or minimal. Advanced alcoholism has significant physical findings depending on the degree of deterioration. The patient will show involvement in one or all organ systems. Like syphilis and tuberculosis in the past, alcoholism has become a great imitator of other disease processes.

The vital signs may reveal a rapid pulse, sometimes with extra beats and hypertension. The patient may show additional signs of withdrawal such as cool skin or diaphoresis.

In advanced cases, a general examination may show varying degrees of jaundice with spider angioma, multiple recent bruises, or healed injuries for which there are no good explanations. A palpable liver, and a protuberant abdomen may suggest ascites.

The extremities may also reveal multiple bruises, recent injuries, or superficial infections. The neurological examination may reveal tremor, peripheral neuropathy, hypo- or hyper- reflexia with a decrease in muscle strength.

The mental status examination will usually be characterized by gross denial accompanied by clearly inappropriate or manipulative behavior. The patient may react in a very hostile, antisocial,

and aggressive manner, confronting the therapist on minute details in order to avoid being examined for alcoholism. He may be suicidal, which should be specifically addressed.

The sensorium may vary on a continuum from clear and alert to obtunded. The affect may range from normal to euphoric or depressed with hallucinations and paranoid delusional systems. The patient may present in advanced stages of withdrawal.

Biochemical Diagnosis

Lab Studies that may help to verify alcohol abuse:

1. Gamma-glutamyl transferase increased.
2. Alanine amino transferase (SGPT) increased.
3. Aspartate amino transferase (SGPT) increased.
4. Alkaline phosphatase increased.
5. Lactate dehydrogenase increased.
6. Transient uric acid elevation.
7. Bilirubin (total) increased.
8. Blood clotting factors, including prothrombin time - increased.
9. Triglyceride and cholesterol - increased.
10. Indications of anemia, including low hematocrit.
11. Low hemoglobin with pathologic findings of anemia.
12. EKG abnormalities - may include cardiac arrhythmias, tachycardia, atrial fibrillation, ventricular premature contractions and abnormal p- waves.

The combination of elevated serum amino transferases, elevated MCV, and elevated triglycerides should raise the suspicion of alcoholism.

Diagnostic Criteria

The following is a list of criteria for diagnosis of alcoholism used by the National Council on Alcoholism. Any one finding is sufficient to make the diagnosis. It should be noted that multiple criteria may not be apparent until an advanced state of alcoholism is present. This is further indication that many cases deemed "alcohol abuse" would most effectively be treated as "alcoholism."

1. Physiological dependence (withdrawal signs and symptoms):
 - a. Gross tremor (alcohol-related).
 - b. Hallucinoses (hallucinations with a clear sensorium).

Alcohol Abuse and Alcoholism

- c. Withdrawal seizures.
 - d. Delirium tremens.
2. Alcohol tolerance:
- a. Blood alcohol concentration 0.1 mg percent during any office visit.
 - b. Blood alcohol concentration 0.15 mg percent without obvious signs of intoxication.
 - c. Blood alcohol concentration of 0.30 mg percent at any time.
 - d. Consumption of a fifth of whiskey or an equivalent amount of wine or beer daily on more than one day by a 180-lb individual.
3. Major alcohol-related illness:
- a. Alcoholic hepatitis.
 - b. Alcoholic cerebellar degeneration.
4. Continued drinking despite strong contraindication(s) known to the patient:
- a. Medical contraindication (pregnancy, alcohol-related medical problems).
 - b. Social contraindication (divorce, separation, loss of job, arrest or citation for driving under the influence of alcohol).
 - c. Blatant and indiscriminate use of alcohol (skid-row behavior).

Psychiatric Interview

Alcohol use and alcoholism is an emotionally laden subject in our society; therefore, the examiner must be aware of his own attitudes and feelings towards alcoholism in his reaction to patients presenting with the problem. He must have worked closely through his own feelings and examined his own social cultural tendency to consider alcoholism as a social problem. He must be diligent in using objective criteria of the illness rather than comparing the patient's drinking history with his own or with his friends'. It has to be continually remembered that denial is the primary defense mechanism used by an alcoholic and most patients will react with avoidance or hostility when their denial is confronted. The examiner must train himself to listen to the style and quality of responses which the patient makes. A person who has no difficulty with alcohol use will usually answer questions on the subject in a very matter of fact way. The person who has had some early or private concerns about his alcohol intake or who is suffering from the effects of alcoholism will usually direct his whole response style with one goal in mind: persuading the examiner that there is "no problem." As the examiner assesses the various areas of the patient's lifestyle and personality functioning, the patient responses will sound superficially negative but subtly qualifying. Such questions as "Do you drink very much?" or "Does your drinking in-

terfere with your family life?" will be answered by superficial but obviously vague-and meaningless responses. Responses such as "not as a rule" or "no more than anyone else" or "not recently" or "not really" or "nothing worth mentioning" or "probably not" should be examined further.

The examiner must learn to titrate the patient's hostility very carefully by first paying attention to the manner in which the patient was relating to him at the beginning of the interview. A baseline is established by noted such items as tone of voice, the degree of friendliness, and presenting emotional distance when the patient was addressing the examiner. The perceived amount of trust towards the examiner and medical people in general and any propensity for paranoid hostility, will markedly change when the examiner shifts his questioning from benign medical topics to subjects that reflect alcoholism. It is important to establish rapport and remain supportive to the extent that the patient will return for subsequent follow-up.

The Cage test by Ewing and Rouse is a very quick but nonthreatening indicator of alcoholism. It is considered 96 percent positive for alcoholism if two questions are answered in the affirmative and almost 100 percent if three questions are answered in the affirmative. The Cage test can be incorporated in questions during the standard routine examination. It is as follows:

- C - Have you ever thought you should cut down your alcohol intake?
- A - Have you ever been annoyed by others complaints about your alcohol intake or behavior?
- G - Have you ever felt guilty over your drinking habits?
- E - Do you need a morning eye opener to feel functional?

Several written screening tests which have become popular in recent years can be used as part of the standard physical examination. One of the more popular is called the Michigan Alcoholism Screening Test or MAST for short (Selzer, 1971). These screening tests are commercially available with instructions.

Confrontation and Intervention Techniques

Alcoholics rarely ask for help because of their own belief that they do not have a problem and do not desire help. Careful review of a patient's lifestyle, crises, and the reason for a presenting medical visit usually reveals that alcohol intervention occurs in a crisis situation in the patient's life. The basic intent of early intervention and rehabilitation is to bring about a crisis earlier in the life of the alcoholic in order that intervention can be followed by rehabilitation before the patient loses the psychosocial resources necessary to participate in the rehabilitation process.

Alcohol Abuse and Alcoholism

Confrontation should be a joint effort involving significant people such as the flight surgeon, the patient's commanding officer, the patient's spouse, teenage children, friends, and chaplain. Confrontation is best done in a formal setting. This can be done in the flight surgeon's office after he has gathered all the information and has individually persuaded several of the significant people to become involved. The flight surgeon must not select people to participate who have a current or longstanding vendetta against the potential patient such as an estranged wife, angry stepson, or intolerant commanding officer. He also must not select people who have an unshakable bond of loyalty with the potential patient such as a crew member or friend whose life the patient once saved or someone who is his "favorite drinking companion." Be aware of "peer denial." Each person in the confrontation setting should have written down a number of items on which he is willing to confront the patient. The items should clearly reflect the situation in which the patient's drinking caused him or others harm, expense, embarrassment, etc. This should involve everyday life situations. The patient must hear these presentations from beginning to end. The theme of the confrontation should be that all parties concerned are there because they love the patient, care for him, and are worried about his health and future. They want him to receive help because they are convinced he has an alcohol problem. It must also be stated that they are: (1) in the case of the family, prepared to leave the patient if he does not get help or, (2) in the case of the command, they are prepared to take proper administrative or disciplinary action if he does not seek help. The entire confrontation has to be orchestrated by the flight surgeon who has before him the patient's health record, service record, available laboratory data, and any other pertinent documentation. If the patient is in acute withdrawal, then it may be best for the confrontation to take place after detoxification. If there are no signs of withdrawal, then the confrontation can occur even though the patient is still emotionally upset and depressed because of guilt in connection with his alcoholic behavior. Referral to the nearest military treatment facility needs to be arranged by the flight surgeon, much as he would make arrangements for any other medical illness. At this time, the patient must be told that alcoholism is a treatable disease and, if applicable, that he will return to full flying status subsequent to treatment and follow-up if he responds properly. Levels of treatment will be discussed under the subsequent heading.

Summary of Confrontation

1. Confront the patient with the consequences of his or her drinking (medical, social, economic) and involve the family.
2. Don't argue over the quantity of alcohol consumed, or the label or diagnosis of alcoholism. Focus on the need to do something about a problem for which there is a treatment.

Rehabilitation Programs

Pertinent Instructions

1. OPNAVINST 5350.4 Series (OPNAVINST 5350.4A of August 1987) is a comprehensive and informative instruction that every flight surgeon should be familiar with.
2. NAVMEDCOM 5300.2 of Feb 87 covers rehabilitation of aviators and aviation personnel.

Alcohol Rehabilitation Facilities

Alcohol Rehabilitation Facilities are organized at three levels:

1. Level I - Conducted by the Naval Alcohol and Drug Safety Awareness Program (NAD-SAP) is an outpatient information awareness program managed by the base counseling and assistance center.
2. Level II - A more intense four-week local nonresidential program, also administered by the base counseling and assistance center. Level I and II are for those judged alcohol abusers and referral may be made by the cognizant command or CAAC. Level III is for those judged "alcohol dependent" and referral must be by a medical officer.
3. Level III - Residential treatment at Regional Alcohol Rehabilitative Services located at selected naval hospitals and two major alcohol rehabilitation centers. It usually takes 6 weeks to move from local treatment to the highest echelon of residential treatment. There is an important tradeoff: increasing staffing resources and technical sophistication are substituted for proximity to both a supportive milieu which might assist in recovery, and distresses and problems which were used to rationalize drinking in the first place. The specific needs of each alcoholic must be considered so that he can be referred to the type of program which is best for him. The flight surgeon should become familiar with the facilities available to him as soon as possible. There will be an opportunity for him to involve himself in the local program, perhaps making presentations to the patients or consulting with the staff.

Unlike other services, the treatment approaches in all naval alcohol Level III treatment facilities are uniform, the patient usually being on a restricted status for the first two weeks of residential treatment. Patients receive a complete physical examination and a psychological

Alcohol Abuse and Alcoholism

evaluation upon admission. After detoxification, if this is necessary, the patient will not be treated with any medications other than disulfaram and multivitamins. The residential facility populations are made up of recovering alcoholics of all ranks and both sexes.

The main features of the six-week residential programs are: (1) group therapy, (2) the leadership of recovered alcoholic Navy active duty counselors, and (3) thorough indoctrination into the principles of the fellowship of Alcoholics Anonymous (AA). The day is filled with group therapy sessions, educational movies on alcohol and alcoholism, didactic lectures, psychodrama, family treatment, couples' therapy, physical fitness, and nightly attendance at Alcoholics Anonymous meetings both on board and in the local community. Often viewed as a "threat" or as punitive, the Level III experience is a true global experience in self-exploration and an opportunity to redefine one's life philosophy and goals.

The treatment philosophy is that the patient is entering treatment because his life is becoming unmanageable because he has lost his ability to use alcohol without causing harm to himself and others. Every effort during the six-week rehabilitation is aimed at bringing him in touch with feelings which he has not been aware of, usually for years, and making him somewhat more aware of the mental defenses which he characteristically uses. The intent is to restore him to a sober, happy person who functions without alcohol and other mind-altering chemicals so that he can again effectively perform his role in the naval community. As a general rule, Navy members are returned to their parent command for follow-up management and disposition.

Follow-up Disposition and Management of the Recovered Alcoholic

NAVMEDCOMINST 5300.2 of 17 Feb 1987 (Series) covers the guidelines for the management of personnel recovering from alcoholism. The instruction refers to "alcoholism", but often it is necessary to think "alcoholic behavior" in order to provide the aviator the best possible chance at recovery. Often the alcohol abuser is most in need of and would benefit most from the mandatory follow-up outlined in the instruction.

Nonaviation personnel returning to their parent commands are indoctrinated into an aftercare program of one year coordinated by their squadron substance abuse counselor and the local CAAC program.

Aviation personnel present more unique problems in disposition. Sometimes in the discharge summaries from residential treatment centers, there may be statements concerning the patient's suitability for returning to flight status that may be used as an advisory. The actual disposition in terms of when and how the patient returns to flying status will ultimately be the responsibility of

the cognizant flight surgeon. He will see the patient back in the squadron environment and will have a daily opportunity to observe the patient and discuss his progress with superiors, family, and friends. It must be kept in mind that persons returning from intensive inpatient rehabilitation programs have a significant amount of emotional work to do to reform their general attitude towards self and life, and this process takes time. As a general rule, it is wise not to immediately immerse the member in stressful situations without first having had some adequate time of observation in order for the patient to readjust himself to his new lifestyle. Antabuse may be a legitimate part of the follow-up program and certainly documented attendance at AA should be required. OPNAVINST 5350.4A mandates a one year follow-up at monthly intervals for all naval personnel successively completing Level II or III. This is coordinated at the squadron or unit level by the DAPA or substance abuse counselor.

Unless the flight surgeon has had some prior indoctrination in an alcohol rehabilitation facility as a participant observer, he may never have had the experience of dealing with a recovered alcoholic. Most successfully recovering alcoholics consider themselves in no way different from other people except that they no longer drink alcohol. Some of the qualities which are indicative of the patient with a good working program of recovery are the following:

1. He no longer drinks alcohol or takes mind-altering drugs of any kind unless they are prescribed for an emergency or an elective surgical process.
2. He comfortably accepts the fact that he has alcoholism. He no longer wonders whether the cause is biochemical, genetic, or unknown, and he no longer hopes that someone will invent a magic pill so that he can drink again socially.
3. He is no longer concerned with his personal anonymity, as a matter of fact, he makes sure that his commanding officer is fully aware that he is an alcoholic.
4. He is actively involved in helping other alcoholics find sobriety, and he regularly attends Alcoholic Anonymous meetings. If he is in family therapy or group psychotherapy, this is an adjunct to Alcoholics Anonymous.
5. His sense of humor has returned, and he can now accept criticism when he is wrong.

It is important that the flight surgeon convey to the patient that he understands the way of life of the recovering alcoholic. This can be done by showing the patient that he is comfortable around nondrinking friends, that he respects the right not to drink, and that he expects the same degree of commitment and the same level of performance from the nonalcoholic as he does from

Alcohol Abuse and Alcoholism

the recovering alcoholic. The best way for the flight surgeon to monitor the progress of the recovering alcoholic flight crew member is to occasionally attend an AA meeting with the patient and his family. For the first year, the flight surgeon should have at least monthly, regularly scheduled, personal interview sessions with the patient. This is above and beyond OPNAVINST 5350.4A requirements. These interviews should take place in the flight surgeon's office like any other interview or examination. If there is any suspicion, or if the flight surgeon obtains any information which suggests that the patient may have relapsed, the patient should be grounded until the flight surgeon is certain of the actual circumstances. If there has indeed been a relapse, the patient will need to be evaluated and a determination made as to whether or not he should be returned for another course of rehabilitation. Refer to OPNAVINST 5350.4 series for guidance or criteria for retreatment. Refer to MILPERSCOMINST 1910.4 series for proceedings for administrative separation as a treatment failure.

Well over half of the participants of Navy rehabilitation programs experience a "recovery" and are maintaining sobriety through the end of their first year after discharge. This is an average figure: the outlook is less favorable for the immature young person for whom alcohol may be one of the many drugs he abuses, and alcohol abuse is just one more means of expressing his dissatisfaction with his life structure. The prognosis is much more favorable for the older, more mature, professionally motivated aviator, NFO, or medical officer. Relapse among the latter groups is unusual: most such people return to successful careers. Likelihood of promotion, selection for command, and assignment to positions of responsibility are, by established policy, unaffected by one's identity as a recovered alcoholic.

Comments on Detoxification

As a general rule, active duty personnel seen in a medical setting with a blood alcohol level over .15 should be admitted for detoxification. This should be considered mandatory if there is any impairment of judgment, any evidence of agitation, hallucinations, threat of suicide, or medical complications (i.e., unable to hold down fluids). If outpatient management is deemed appropriate, or under some circumstances mandatory, the patient should receive Thiamin 100 mg intramuscularly and at least a week's treatment of 50 mg orally daily. His treatment plan should be discussed with a friend or relative who not only can monitor compliance but notify medical personnel if complications should arise. For mild agitation and withdrawal symptoms, chlor-diazepoxide (librium) 50 mg orally every two hours as needed for three days followed by 25 mg orally every two hours for an additional three days should be sufficient to control withdrawal symptoms. Symptomatology above this treatment level strongly suggests the need for hospitalization.

Be extremely cautious in sending a person away from a treatment facility if his blood alcohol is above .15 or if he is in any way impaired. Never send an intoxicated person out unescorted or without medical follow-up.

Inpatient treatment is suggested for detoxification of all active duty personnel and for those for whom close support is not available. A basic plan for appropriate inpatient care would be as follows:

1. Thiamine, 100 mg I.V. or I.M. given immediately followed by 50 to 100 mg orally or intramuscularly daily. Folate orally 1 mg day and a multivitamin tablet daily should be prescribed unless the patient is obviously B12 deficient, in which case the latter must be replenished first.
2. Sedation often provides symptomatic relief from withdrawal symptoms and makes management possible. There is no good evidence that sedation will prevent the emergence of delirium tremens. Neuroleptic drugs should be avoided because they can cause hypotension, autonomic symptoms and extrapyramidal symptoms that will complicate the withdrawal picture. Chlordiazepoxide, 50 mg orally every two hours as needed for three days followed by 25 mg orally every two hours is usually sufficient. Vital signs should be monitored frequently and the drug given only for objective signs of withdrawal such as hypertension, tachycardia, or tremor. Total daily doses should rarely exceed 400 mg.

In more severely agitated patients, or patients who cannot take oral medication, diazepam 5 to 10 mg given slowly and intravenously every fifteen minutes until sedation is achieved followed by 5 mg I.V. or 10 mg orally as needed can be used. Careful monitoring of vital signs is necessary.

Fluid and electrolyte imbalances must be corrected vigorously. Magnesium deficiency is common and should be corrected.

Seizures are of great concern and almost always begin within 24 hours. These manifest as generalized tonic-clonic seizures. About one third of the patients who develop seizures will have only one. Two thirds of the patients will have multiple seizures, often closely spaced. Only about two percent of the patients will develop status epilepticus and most of them are epileptic patients who have discontinued their anticonvulsant medication. Many seizures can be prevented by replacing serum magnesium. If seizures occur, anticonvulsants can be given. Prophylactic use of anticonvulsants requires a full loading dose within the first 24 hours which may produce more risks than benefit. The drug of choice is phenytoin (Dilantin). Follow standard *Physicians' Desk*

Reference dosing. If seizures begin later than 24 hours after beginning of abstinence, if they continue for an extended period of time or status epilepticus occurs, or if there are focal seizures, a source other than withdrawal must be sought (i.e., head injury). For pure alcohol withdrawal seizures, long-term use of an anticonvulsant is not indicated.

Delirium Tremens

1. Delirium Tremens, often called the DTs, is a term best reserved for the severe late onset symptoms that occur in a small minority of patients. Despite optimal therapy, delirium tremens often result in death in about 15 percent of the cases.
2. Clinical manifestations often include an orderly progression of symptoms from the earlier milder, symptoms to delirium tremens. The syndrome may begin 24-72 hours after abstinence, and 90 percent of patients will develop DTs within seven days. The syndrome is characterized by marked sympathetic overactivity, hallucinosis, severe anxiety, agitation, confusion, fluctuating mental status, motor restlessness, and combativeness.
3. Death results from volume depletion, electrolyte imbalance, infection, and cardiac arrhythmias. Unless proper precautions are taken to restrain a patient, death may result from suicide (while fleeing frightening hallucinations).
4. Treatment is best carried out in an intensive care unit if available.
 - a. Intravenous dextrose and saline should be given at a rate adequate to replace fluid losses and maintain blood pressure. In cases of circulatory collapse, pressors may be needed.
 - b. Hyperthermia should be treated aggressively with an acetaminophen for temperatures above 101 degrees F. and with cooling blankets for temperatures above 103 degrees F.
 - c. Parenteral thiamine 100 mg per day should be continued at least until normal diet is resumed.
 - d. Sedation helps diminish autonomic symptoms and agitation. Parenteral administration is best because most patients would not be able to take anything by mouth. Diazepam 5 to 10 mg intravenously can be given every 15 to 20 minutes until sedation is achieved. Repeat doses should be given as needed.

- e. All severely agitated or combative patients should be restrained. Restraint should be carefully managed in order to avoid decubitus ulcers and nerve compression or traction injuries.
- f. Reassurance and explanations to the patients are helpful.
- g. Infections such as pneumonia should be suspected and treated with appropriate antibiotics if present.

Summary

Excessive drinking as a sign of manliness is probably as old in aviation as aviation itself. Alcoholism and alcohol-treated problems historically have been ignored and treated administratively and punitively in the Navy. Since 1971, the Naval Alcoholism Prevention Program has helped bring about significant changes. Through education, alcoholism is now recognized as a chronic, progressive, and relapsing disease which affects members of the aviation community just as it affects other people. It is essential that the flight surgeon learn to think of alcohol as a sedative, hypnotic drug and that he be familiar with the potential hazards which excessive use of this drug presents to the aviation community.

The history and physical examinations done in connection with alcoholism present a unique problem in medicine in that the patient's primary defense mechanism, denial, usually makes him an unreliable historian and, therefore, other sources such as spouse, friends, superiors, and health records need to be utilized. The diagnosis should be based on objective criteria met in the Diagnostic and Statistical Manual of the American Psychiatric Association. It is important to begin to see detoxification not as a treatment, but as a means for referring the patient for proper rehabilitation. The examiner should be alerted to the possibility of alcoholism whenever the patient goes overboard in his efforts to convince the flight surgeon that there could not possibly be such a problem in his life. Alcoholics only get into treatment as a result of a life crisis which can be brought about earlier in the disease process by confrontation and intervention. Confrontation needs to be orchestrated by the flight surgeon and should involve significant others, such as family members, friends, senior officers, and the chaplain. The aim of confrontation is to assure the patient that significant people are concerned about him, and that they insist on his going for treatment. At risk is the possibility of family members leaving him and superiors instituting administrative or disciplinary actions.

Rehabilitation means restoring the patient to a way of life in which he can function without the use of alcohol or other mind-altering drugs in his capacity as a flight crew member and as a

Alcohol Abuse and Alcoholism

member of his family and society. Follow-up care means not only checking on the patient's abstinence but, more importantly, being aware of, and ideally, being a part of his ongoing emotional growth. This can be accomplished by being briefly involved in his Alcoholics Anonymous way of recovery. Also of importance, is holding monthly interviews in the flight surgeon's office with the patient, and occasionally with family members and senior officers.

The flight surgeon has a very important role to play in shaping the drinking styles of his flight crew. A letter from former Surgeon General of the United States Navy, Vice Admiral W.P. Arentzen, has this to say about the drinking practices of the Navy:

“The time has come to focus on prevention, as well as rehabilitation. Our seafaring tradition includes rituals with heavy drinking, based on tenacious myths that heavy drinking signifies vigor and promotes good fellowship. Such folklore stemming from the days of the galleons has no place in modern medicine in a modern navy. It is incumbent on us in the Medical Department to dispel these myths, not only by our utterances, but more importantly by our leadership actions and by our example. Take a close look at irrational drinking customs at your command, take remedial action, and insist that your staff members act exemplarily and responsibly in their consumption of alcohol, or avail themselves of rehabilitation. It is my desire that the Medical Department take a leading role in the curtailment of irresponsible drinking in the Navy.”

References and Bibliography

- American Psychiatric Association. *Diagnostic and statistical manual of the American Psychiatric Association* (DSM-III-R). Washington, DC: American Psychiatric Association, 1982.
- Hyman, S.E. (Ed.). *Manual of psychiatric emergencies*. Boston: Little Brown, 1985.
- Selzer, M.L. The Michigan Alcoholism Screening Test. *American Journal of Psychiatry* 1971, *127*: 1653.
- Schukit, M.A. *Drug and alcohol abuse, a clinical guide to diagnosis and treatment*. New York: Plenum Press, 1985.
- Woititz, J.G. *Adult children of alcoholics*. Pompano Beach, FL: Health Communication. Inc.
- Yesavage, J.A. & Leirer, V.O. Hangover effects on aircraft pilots fourteen hours after alcohol ingestion. A preliminary report. *American Journal of Psychiatry* 1986; *14*: 1546-1550.

Acknowledgment - 14 April 1989

The energy and direction for reasonable and timely treatment of alcoholism in Navy personnel has to be credited to Captain Joseph Pursch, MC, USN, (Ret.). He was the principle contributor to this chapter in the 1978 edition of the *U.S. Naval Flight Surgeon's Manual*. In this revision, all efforts have been made to retain Captain Pursch's unique insights and methods of dealing with alcoholism. I have tried to incorporate DSM-III-R criteria into the diagnostic approach. Changes in philosophy and policy have been noted where appropriate. For administrative management, the latest changes in pertinent instructions and the addition of new instructions have been included. It is the hope and desire of the Naval Aerospace Medical Institute (NAMI) Department of Psychiatry that the operational flight surgeon continues to find this chapter an invaluable resource in the management of alcoholism in naval personnel.

J. C. BAGGETT
CAPT. MC, USN
Head, Aviation Psychiatry
Department, NAMI
14 April 1989

CHAPTER 19

FATIGUE

Introduction

Sustained Operations and Fatigue

Sleep Deprivation

Circadian Desynchronization

Identifying Signs of Performance Decrement

Preventing Performance Degradation

Role of the Flight Surgeon

References and Bibliography

Introduction

Long-range flight operations and multiple-day missions are currently operational realities in naval aviation. Within a variety of naval aviation communities flight operations are characterized by sustained mental and physical effort and prolonged vigilance which leads to fatigue. Fatigue is unquestionably a major consideration during many military flight operations. There are, however, many questions and unresolved issues concerning the manner in which fatigue develops, its importance in various missions, and the best way to manage it. The flight surgeon is in a key position to assist operating personnel in dealing with the multifaceted and ill-defined problem of fatigue.

Fatigue has been the subject of investigations for many years. These investigations revealed difficulties in classifying fatigue, or performance decrement resulting from fatigue. These difficulties are related to the fact that the word has no specific scientific meaning and does not represent a distinct clinical entity. Instead, "fatigue" refers to a group of phenomena associated with impairment or loss of efficiency and skill. As a complaint it probably indicates sleep deficit, disruption, or deprivation associated with prolonged periods of work, amidst the multiple operational stresses of flight. It involves a subjective appreciation of tiredness, momentary lapses of attention, and possibly impaired psychomotor performance. In view of the many operational stresses of flight, it is probable that all of them induce fatigue to some degree. For the flight surgeon, practicing operational medicine, "fatigue" may be considered as a state of decreased performance resulting from an accumulation of the inherent stresses of military aviation.

U.S. Naval Plight Surgeon's Manual

The flight surgeon involved with military operations must be intimately familiar with each of the stresses that aircrew may encounter in flight. A typical list of the stresses which aircrew may encounter includes the following:

1. Sleep deprivation, deficit or disruption.
2. Work and rest schedules that result in circadian desynchronization.
3. Enforced sitting posture and restriction of exercise during the long hours of flight.
4. Alterations in nutrition and fluid requirements as well as available sources of food and liquids.
5. Cockpit ergonomics and equipment discomfort.
6. Thermal stress made worse by such things as chemical defense protective clothing.
7. Noise.
8. Vibration.
9. Motion Sickness.
10. Hypoxic environments, atmospheric pressure changes, humidity and temperature differences.
11. The effects of drugs such as caffeine, alcohol, antihistamines, and antiemetics, etc.
12. Problems with the excretion of waste, bladder distention, constipation, diarrhea, and gastrointestinal distention due to barometric pressure changes.
13. Middle ear problems related to barometric pressure changes such as pain of aerotitis or vertigo.
14. Accelerative forces and G-related stress.
15. Psychological stresses related to military aviation, sustained combat missions and the interrelationships among all of these factors.

Fatigue

The cumulative effects of all of these factors can eventually take their toll and may reduce individual effectiveness and increase accident potential. Therefore, in aviation, fatigue is always a potential threat to the success of the mission and to flying safety.

Sustained Operations and Fatigue

The operational consequences of sustained operations (continuous performance of tasks over a prolonged period) have long been recognized. George F. Marshall's observation during the Normandy Operation in World War II vividly portrays the problems: disorientation, overwhelming sleepiness, and inability to give and receive orders due to uncontrollable lapses in attention and poor memory.

Each sustained operation will contain one or more episodes of continuous work during which time there will be no pause for rest or sleep. Three primary factors have limited the duration of continuous work during sustained operations in the past: (1) limited vision at night, (2) equipment limitations and unreliability, and (3) limited endurance of personnel. With advances in aircraft technology, sustained operations are no longer limited by aircraft reliability, weather, or darkness. The duration of continuous work episodes is now determined primarily by human endurance, which is limited by fatigue and the need for rest and sleep.

The operational consequences of fatigue will play an increasingly important role in naval aviation because of the premise that sustained operations can be a "war winner." The advances in military technology and resultant changes in doctrine dictate that future conflicts will likely be high intensity sustained operations lasting several days to weeks. Since it may not be possible to bring additional forces to bear immediately, aircrews may have to perform at intense levels for extended periods with minimal or no rest or sleep. Rest will be dictated by the nature of the situation and may be fragmentary at best. Even when able to sleep, aircrews will be expected to awaken quickly to fly their missions. It is imperative that high levels of performance be maintained under severe conditions and that we learn the best way to manage the concomitant problems of fatigue.

An extended time period which includes both continuous work episodes and relatively quiet periods is typical for a sustained operation. A battlefield environment has varying levels of intensity. There are distinct phases such as predeployment, movement to contact enemy forces, combat, consolidation, regrouping, and resupply. The periods of intense and continuous fighting with no chance for rest or sleep may occur many times during a sustained operation. However, there are also relatively quiet periods with opportunities for short periods of rest and sleep.

The flight surgeon must be concerned with how to identify, prevent and cope with deteriorating performances, poor moods, and lowered willingness to work caused by fatigue and lack of sleep.

He must be able to advise the operational forces when and how they will best be able to recuperate from the stress and fatigue of continuous work episodes and maintain, as an individual and as a fighting unit, combat effectiveness during a sustained operation.

Sleep Deprivation

Although performance depends on complex interactions between tasks, work schedule, environmental stresses, and the individual, it will certainly be impaired when the aviator becomes sleepy. The disruption of the sleep-wakefulness cycle with some sleep loss is likely to be a problem in all air operations which extend beyond a single day, and sleep loss is likely to intensify as the duration of the mission increases. The need for sleep (sleep deprivation) is probably the major component contributing to operational fatigue in continuous work episodes during sustained operations.

Although fatigue and sleep deprivation can be defined as acute, chronic, or cumulative and correlated to some extent with biochemical aberrations, we are unable to determine objectively at what point an individual will experience a performance decrement. Difficulties in determining when fatigue and sleep loss result in impaired performance stem from the fact that laboratory performance tests may not be sensitive to the type of deficits which occur. In addition, the effects of fatigue and sleep loss may vary.

Variables such as extensive training, high motivation, and interest can counteract some of the effects of sleep loss and fatigue. Performance decrement is not always present in all individuals and may be intermittent. However, as fatigue and sleep deprivation accumulate, symptoms will be more prevalent and last longer. There is a point beyond which the need for sleep will overwhelm anyone. When these symptoms appear in each individual depends not only on hours of wakefulness but also on tolerance to sleep loss, type of tasks to be performed, severity of physical workload, and time of work in relation to the individual's circadian rhythm.

During operational conditions there is always doubt concerning the extent of sleep loss, as it is difficult to avoid very short periods of sleep. In field studies it is difficult to suppress sleep, and total loss of sleep has probably only been achieved in laboratory experiments when the electroencephalogram has been continuously monitored. During laboratory experiments involving long periods of wakefulness, drowsiness and microsleeps readily occur. They become more frequent as the period of wakefulness continues, and if not immediately aroused the individual will rapidly fall asleep. Therefore, sleep loss is a continuum which extends from a normal sleep-wakefulness pattern to microsleeps and drowsiness and finally to total sleep loss. There is little evidence, however, that drowsiness (the transition between wakefulness and sleep) or microsleeps preserve performance in sustained wakefulness.

Fatigue

Early studies of sleep loss did not consistently detect impaired performance, though changes in mood were obvious. In these early studies, most subjects functioned fairly well during restricted sleep schedules, but many of the tests used did not reflect the complex tasks that are required in tactical aviation during sustained operations. Their failure to detect impairment is not surprising. Because many of the studies estimating performance decrement in sustained operations included a mixture of more or less sensitive cognitive tasks, intermittent testing, and nondemanding interest intervals, their estimates of expected performance degradation were felt to be conservative.

Studies providing the best estimates are those where the environmental demands are more continuous and there is more time devoted to tasks of higher cognitive demand. As the approach to measurements of performance became more sophisticated, it was found that absence or delay in response rather than accuracy was the important effect, and it was in this way that the importance of adequate sleep to sustain performance was first established. Although there are still difficulties and obvious limitations in accepting the operational relevance of much of the scientific information available on the effects of fatigue and sleep loss during sustained air operations, it would be unwise to ignore the implications of experimental findings to date.

Recent laboratory investigations of total sleep deprivation in sustained operation environments have demonstrated that substantial reductions (greater than 30 percent) occurred in mood and performance after 18 hours of continuous testing, and generally unacceptable performance (greater than 60 percent reductions) occurred following 42 hours of sustained wakefulness. Complex tasks, prolonged, repetitive, and boring tasks were particularly sensitive to sleep deprivation. Similarly, tasks which involved short term memory, newly learned skills, and those skills not well practiced, were vulnerable to sleep deprivation, though self-paced tasks and feedback on performance levels were able to reduce the effect. It appears that, for some less specific skills, even shorter periods of sleep loss may impair performance. Scanning ability may be reduced, susceptibility to disorientation may be increased, and the ability to read charts may be affected. Probably most importantly, impairment of interpersonal skills and mood may result in failure of command, control, and crew coordination.

Although the adverse effects of total absence of sleep extending beyond 24 hours are well recognized, impairment related to less severe degrees of sleep loss or irregularity of sleep are equally important. The most likely sleep problems encountered by aircrews in sustained operations are fragmented sleep associated with partial sleep loss, disruption of sleep-wakefulness cycles and circadian rhythm disruption. For some individuals, the loss of only two and a half hours of sleep each night for two nights has been shown to impair vigilance the next morning, and so it must be suspected that repeated partial sleep loss will lead to impaired performance after several days of irregular work and rest. In addition, irregularity of sleep and the disruption of the normal sleep-wakefulness cycles, rather than a reduction of total hours of sleep, is also likely to

disturb performance. The factors which influence performance with total sleep loss are probably equally relevant to those which occur with partial sleep loss or disturbed sleep due to irregularity of work and rest.

In conclusion, the effects of disturbed sleep (total absence, partial loss or irregularity) will continue to be a dominant issue in sustained air operations. Sleep is essential to sustain high levels of vigilance and maintain effectiveness. Careful attention to sleep is all important because impaired performance follows sleep disturbance even though impairment may not be easy to demonstrate.

Circadian Desynchronosis

Some studies suggest that the fragmentation of sleep and circadian desynchronosis (changes in circadian rhythm patterns and their interrelationships in man) have more importance than lost sleep on subjective mood or objective performance changes. Others feel that it is sleep deprivation and not necessarily circadian desynchronosis which is the more important factor. For the flight surgeon concerned with operational fatigue, sleep deprivation and desynchronosis may be considered as being so entwined that each is essentially inextricable from the other.

In recent years, a large body of information has accumulated showing time of day effects in performance, ranging from simple observations of performance at different times in the normal working day, to complex studies of work-rest schedules over prolonged periods. As a result of these studies, circadian rhythms in task performance, as well as subjective ratings of mood, fatigue, and motivation have been well established.

Circadian desynchronosis will adversely influence performance in operations which require vigilance at times when the aircrew is usually asleep. Body temperature as well as the scores on most performance tests decline to a minimum between 0300 and 0600 hours and rise to a maximum during the day between 1200 and 2100 hours. It has been shown however, that there is no direct cause and effect relationship between body temperature and performance level. The range of oscillation in performance degradation during sustained operations depends on the phase of the circadian cycle it coincides with. When the operation commences during the beginning of a peak in the circadian cycle, the effect of fatigue is compensated in part by the increasing level of arousal during the day; when the operation commences during a period of decline in the circadian cycle, then the fatigue adds to the depression of alertness naturally occurring at night.

Circadian desynchronization can occur in other ways than when a mission has to be flown during the hours normally reserved for sleep. When an abrupt phase shift in the environmental timing system occurs, such as during rapid transmeridian flights, there is a transitory desynchronization of the individual's circadian rhythmicity. This scenario is frequently seen in aircrew involved

Fatigue

in world-wide operations. Another scenario involves fighter and attack aircraft which normally fly multiple short-duration missions separated by periods of nonflying activity. If this sequence continues around the clock, as in the case in some sustained carrier-based flight operations, then rhythm disturbances similar to those caused by rapid transmeridian dislocations may occur. Finally, when changes occur in environmental cues or these cues become weakened or disappear completely, as occurs in space operations, arctic living, or confinement to a shelter, circadian desynchronization may occur.

In summary, fatigue, sleep loss, and circadian desynchronosis are so operationally entwined that a flight surgeon may consider them essentially inextricable from each other. The cumulative effects of sleep deprivation combined with circadian rhythm disturbances will result in impaired performance during sustained operations.

Identifying Signs of Performance Decrement

Identifying signs of an individual's performance degradation is a crucial first step in the management of fatigue and sleep loss involved in sustained flight operations. Factors that are known to affect performance degradation include:

1. Mood and Motivational Changes

Early symptoms of fatigue and insufficient sleep include less positive and more negative moods. Individuals may report feeling less willing to work due to lack of energy or feeling less alert, more irritable, and increasingly negative and sleepy. Individuals who regard sleepiness and mood changes as signs of weakness often deny negative moods and tiredness but may admit to decreased positive mood. Interest and motivation often decide whether performance will be altered. Interesting tasks with relatively simple motor skills are resistant for periods as long as 60 hours, but routine monotonous tasks show a rapid decrement after 18 hours without sleep. Decreased initiative and increased negativism and irritability may lead to a decreased willingness to report events and to interact with other aircrew.

2. Impaired Attention

Fatigued and sleep deprived individuals have a shortened attention span and cannot concentrate on specific tasks with the same vigilance and sustained alertness as when they are rested. Intermittent dream-like intrusions or irrelevant thoughts cause lapses of attention and decreased ability to concentrate. As fatigue and sleep deficit progress, the duration and number of lapses of attention increase.

3. Memory Loss for Recent Events

A well-recognized sign of sleep loss is the inability to recall what you just heard, saw, or read. Memory loss is limited to short term memory of recent events. An individual who is fatigued and sleep deprived may remain confident about retaining messages, data, and events only to realize later that these have been forgotten. Loss of sleep for 24 hours impairs the acquisition of information and newly retained material. After 48 hours of continuous work there is a drop below 40 percent of baseline levels of performance on tests that require recent memory.

4. Variable and Slowed Responses

During continuous work episodes speed and accuracy suffer. Speed is most often decreased in order to maintain accuracy, not necessarily as a slowing down of all responses, but more as an unevenness in response time. Some responses remain fast; others become delayed. The danger of fatigue and sleep loss is the unpredictable slowing down of appropriate responses. Depending upon the task, some situations are more sensitive to sleep loss and fatigue than others, and the longer the tasks, the more obvious are the changes. The loss of one night's sleep may have little effect during the first five minutes of a vigilance task, but when the task is extended to 15 minutes, performance deteriorates. Total sleep loss after 50 hours impairs responses after three minutes and after 70 hours responses are impaired within only two minutes. Increasing the difficulty of the task causes variable and slowed responses to be even more sensitive to performance decrement. When an addition task is required every two seconds no change can be detected even after two night's sleep loss, but when the speed of addition is increased to one problem every 1.25 seconds, effects are usually observed.

5. Lack of Insight on Impaired Performance

Deficits associated with continuous work episodes may be underestimated and disregarded. Individuals may be more easily satisfied with lower levels of performance and errors may be recognized but not corrected. Decrements in performance on a primary task can be avoided, but secondary tasks, incorrectly thought to be less critical, are impaired. In addition, the individual may lose flexibility of approach and the ability to perceive or adjust to new aspects of a problem.

6. Impaired Task Performance

As sleep deprivation continues, the individual's performance may continue on a reasonable level of efficiency but will be broken by lapses of attention. Sleep deprived subjects may carry out tasks accurately, but their periods of accuracy become briefer and more infrequent as the depriva-

tion continues. Performance decrement is seen as brief intermittent lapses in performance which increase in frequency and duration. Impaired performance, therefore, is seen as missed signals and failure to respond to task demands (errors of omission) and less frequently results in responding to task demands indiscriminately or inaccurately (errors of commission).

These increasingly frequent errors of omission are particularly relevant to antisubmarine warfare (ASW) patrol, long-range attack missions, or air combat scenarios where target detection is critical and an error of omission may lead to failure of the mission and catastrophic results.

7. Failure of Interpersonal Skills and Crew Coordination

A major factor in the success or failure of a flight operation is the ability of the aircrew to maintain command, control, and crew coordination. Aircrew coordination problems typically fall into one of three broad categories: (1) improper task prioritization, (2) ineffective communication, or (3) lack of coordinated action. Unfortunately, these type of skills are most susceptible to fatigue and sleep loss induced performance degradation which is inherent to sustained flight operations. It is well known that fatigue and sleep disturbance modify circadian functions, impair response to stress, and upset the normal sense of well-being, but the measurement of performance is insufficiently sensitive to easily detect many important behavioral changes.

Performance during continuous work is maintained by greater effort and by concentrating attention on a limited aspect of the problem, thus interpersonal skills are likely to deteriorate even though the loss of these skills is difficult to demonstrate. While certainly not an all-inclusive list, interpersonal skills likely to deteriorate include discipline, leadership, "followership," situational awareness, judgment, prioritization, decision making, workload sharing, and communications. Changes in mood such as increased hostility, irritability, inability to concentrate, impaired perception, and disorientation are similarly experienced with only one night of sleep loss and are likely to be a problem in all continuous air operations which extend beyond a single day. This loss of command, control, and crew coordination capability has importance far beyond the performance degradation of skills that are more easily measured.

Preventing Performance Degradation

Placement and Length of Sleep Periods

Because only fragmentary rest episodes will be available during sustained operations, it is important to be able to specify both the minimal amounts, and the optimal temporal placement, of sleep periods required for maintaining or recovering effective performance.

Breaks (rest periods without sleep) have been found to be beneficial for individuals-involved in sustained operations. Performance and mood scores are consistently better immediately after breaks than an hour into the work sessions and seem-to have a short-lasting positive influence. Thus, breaks may provide a means by which temporary increases in performance may be achieved during sustained operations, but they do not appear to have any long-term beneficial effect.

The most obvious intervention for counteracting the effects of fatigue and sleep loss is sleep itself. If extended uninterrupted sleep periods are not possible, any amount of sleep is better than no sleep, and the longer the sleep period the greater the recovery of alertness. There are several stages of sleep: Stages 1, 2, 3, 4 and Rapid Eye Movement (REM). Early studies suggested that one type might be more beneficial than another; however more recent research reveals that it is the total amount of sleep and not the amount in a specific stage that is important.

Sleep cannot be stored in our bodies for later use. A sleep of much greater duration than the normal seven to eight hours, taken before deployment, does not store-up excess sleep and subsequent sleep loss is no better tolerated. Although it is important not to start on sustained operations already sleep-deprived, long sleep will not result in a greater tolerance to sleep loss.

Research to date has indicated a general lack of effect of physical fitness levels, scheduled physical exercise, short bursts of strenuous physical exercise, or periods of low workload on sustained performance. However, it is important to note that these studies have been conducted only in environmentally neutral laboratory settings. It is quite possible that physical condition could have a significant impact on the sustainability of performance in environmentally hostile settings such as an aircraft cockpit where one is exposed to multiple physiological stressors (e.g., heat, cold, altitude, acceleration, and G-induced stress). Physical condition may yet be found to influence endurance limits during sustained operations in naval aviation.

Recovery from continuous sleep deprivation is rapid, and usually reached within 15 hours. After 36 to 48 hours of continuous work without sleep, baseline performance is regained after 12 hours of rest, although mood changes persist. Furthermore, regardless of how long the period of wakefulness is, there is a dramatic improvement in performance and behavior after only one night of sleep.

Some suggestions regarding minimal amounts of required sleep come from the partial sleep deprivation literature. These studies are primarily concerned with determining how little sleep is required to maintain normal performance levels. It is generally maintained that a minimum of three to four hours of sleep are needed during the first night of reduced sleep to maintain performance. During the second and subsequent nights, at least five hours are required every 24 hours to maintain effective performance.

Fatigue

Other studies have been concerned with investigating the minimal amounts of sleep required to improve performance over no-sleep conditions. It has been shown that naps of only two hours duration are beneficial compared to no sleep. Studies have also investigated the impact of distributed short sleeps and have found that the minimal times required for beneficial performance effects are similar to those suggested by the results of the partial sleep loss studies describe above. For example, experimental subjects that were given five one hour naps each day for two days showed fewer decrements in performance than control subjects who underwent total sleep loss.

Some studies have directly investigated whether these minimal suggested amounts of sleep are more beneficial when taken as multiple short sleeps (distributed naps) or as longer continuous naps. In one study a group of subjects was allowed three one-hour naps each day for two days. The nap subjects performed better than subjects who were completely sleep deprived, but not as well as those subjects who received the same amount of sleep (six hours) in a continuous block. Thus, it appears that both single and multiple naps within 24-hour periods reverse disruptions on performance and mood related to sleep loss. Longer naps usually have greater benefits in terms of mood, performance, and alertness.

Nap placement in the circadian cycle may be as important as nap duration in determining the effectiveness of short recovery sleep. Depending on their placement in the circadian cycle, and how much prior sleep loss has accumulated, naps have been found to have both a maintenance and a restorative effect. For example, a premidnight two-hour nap prevented decrements that usually occurred during and after a second night without sleep, therefore, performance was *maintained* at the premidnight level. A nap taken at the low point in the circadian cycle, which followed the expected onset of postmidnight performance degradation, was shown to *restore* performance levels to the premidnight level. Thus, a two- hour nap taken from 0400-0600 appeared to provide some recuperation of cognitive performance.

How quickly one regains his ability to work efficiently after awakening from sleep (sleep inertia) poses a further problem. Decrements are present immediately after being awakened from periods of sleep. The later in the night this awakening occurs the greater the impairment becomes. Recovery time is longer for simple, discrete tasks but return to normal working levels may take as long as 20 minutes. Very low performance is encountered on awakening from sleep after a stressful period of work which involves sleep loss. More complex tasks require a longer recovery time. The use of alarms does not accelerate recovery, though a few minutes of rest immediately after awakening offsets the decrement of the subsequent performance. Thus, working in a concentrated manner after a sudden awakening may adversely affect the capacity to perform effectively for a short period of time.

In summary, the scheduling of naps in the circadian cycle, the amount of prior sleep loss, and the type of tasks to be executed during the mission, and duration of sleep inertia, are important factors that must be considered during development of nap strategies as a countermeasure to performance decrement.

Drugs

Hypnotics. The management of U.S. Naval aircrew with sleep difficulties which arise from the pattern of irregular work and rest encountered during sustained operations may involve the possible use of hypnotics at some future date. Periods during which the aircrew can rest are likely to be scheduled at unusual times of the day and under circumstances which may not be conducive to sleep. Much progress has been made in the development of hypnotics with a limited duration of action for personnel involved in skilled activity in whom the predominant problem is disturbed sleep resulting from sustained flight operations. A hypnotic which can decrease sleep latency, preserve normal sleep architecture and is free of residual sequelae is required. Because of the critical nature of the requirements of naval aviation, more information is needed on the use of these drugs in the management of the irregular patterns of rest associated with such operations.

Stimulants. Another potential use of drugs in intensive operations is that of stimulants to maintain vigilance during long periods of duty without rest or sleep (e.g., long-range missions where the pilot is too mentally and physically exhausted to safely perform at the target or to recover on board, or when a pilot has already flown one very long mission or multiple missions and a re-strike capability is desired.) The use of stimulants is a complex issue which is currently under investigation. Presently, our knowledge of these drugs is not adequate to encourage their use in military operations.

Caffeine, however, is used widely by aircrew to maintain alertness, and its use over many years provides support for the safety of the drug. Caffeine can lead to problems such as tachycardia, diuresis, and can impair subsequent sleep; however, it maintains wakefulness overnight and preserves vigilance. Caffeine is used to preserve vigilance even under circumstances when sleep between missions has been maintained. It is possible that, in the not too distant future, advances in our knowledge of stimulants other than caffeine will allow for a more sophisticated approach to maintaining vigilance.

Management of Fatigue

The management of operational fatigue in military aircrews that work and train for intensive and sustained air operations is problematic. Sustained operations incompatible with sufficient

Fatigue

sleep and mission requirements which preclude scheduling of duty to avoid marked drops in performance due to a combination of prolonged duty and the nadir of circadian performance, will remain operational realities. Coping with irregularity of rest and sleep loss that is superimposed upon poor sleep and fatigue is likely to be a major problem that the flight surgeon is in a unique position to deal with.

Role of the Flight Surgeon

The flight surgeon is in a unique position to deal with the multifaceted problems of operational fatigue, principally because his orientation is directed more toward the safety aspects than the operational aspects of the mission. Senior operational personnel are appropriately concerned with mission accomplishment. Although safety is never ignored, the main objective is mission accomplishment. If more hours need to be flown in order to accomplish a mission, those hours will be flown.

Aviators themselves are not always in a good position to evaluate operational fatigue. Pressures from superiors, peers, and self-image all combine to make it most desirable to "press on" with the last ounce of reserve energy rather than to ground ones self because of excessive fatigue.

A flight surgeon, because he is in a unique position to judge the general fitness of an aviation unit with some objectivity, bears certain responsibilities to that unit. Proper rest can do much to stave off the cumulative effects of operational fatigue. Although sleep schedules are of lower priority than mission assignments, a flight surgeon still can do much to help the situation by bringing the need for appropriate rest schedules to the attention of command personnel. Similarly, a flight surgeon might advise the command that, whenever possible, critical mission segments (e.g., aircraft recovery) should not be scheduled at the same time as the maximum behavioral depression in the circadian trough.

In addition, there are many stressors in the aviation environment which can add to operational fatigue in the sense of allowing an aviator to be less able to handle operational fatigue than should be the case. Some of these issues are inadequate diet and irregular meal schedules, uncomfortable or improperly sized equipment, personal difficulties, and poor physical condition. To the extent that these or similar problems are observed, a flight surgeon has a responsibility to begin a corrective program and to be even more alert than usual to be able to detect the onset of operational fatigue.

Operational units that participate in sustained operations must be closely monitored. It is a relatively simple matter to trace the antecedents of an accident and to record the amount of sleep

within the last 48 hours, the time since a last nourishing meal was eaten, and the number of times a scheduled mission was cancelled or shifted. With appropriate data, a flight surgeon can clearly make the case of operational fatigue as an accident cause. It is much more difficult to evaluate ongoing events and decide when operational fatigue has built to the point where individual safety and mission proficiency are jeopardized. However, a flight surgeon must attempt to do this. This means that he must be in touch with aviation units during periods of training for, or execution of, sustained operations. The flight surgeon must observe the day-to-day condition of individual aviators and aircrew and must be prepared to recommend grounding when he thinks that fatigue has become excessive and dangerous. It is always more important to prevent the accident rather than to describe it.

References and Bibliography

- Aller, F. Medical functioning and circadian dysrhythmia. *Military Medicine*, 1987, 152 (6). 308-319.
- Angus, R.G., Heselgrave, R.J., Pigeau, R.A., & Jamieson, D.W. Psychological performance during sleep loss and continuous mental work: The effects of interjected naps. Lyon, France: NATO Seminar, 16-17 March 1987.
- Angus, R.G., Heselgrave, R.J., & Miles, W.S. Effects of prolonged sleep deprivation, with and without chronic physical exercise, on mood and performance. *Psychophysiology*. 1985, 22, 276-282.
- Dewulf, G.A. Continuous operations study (CONOPS). USACAC Technical Report No. Z01707, 1987.
- Dodge, R. Circadian rhythms and fatigue: A discrimination of their effects of performance. *Aviation, Space and Environmental Medicine*, 1982, 53, 1131-1136.
- Haslam, D.R. The military performance of soldiers in continuous operations: Exercise Early Call I and II. In Johnson, L.C., Tepas, W.P., Colquhoun, W.P., & Colligan, M. J., (Eds.), *Biological rhythms, sleep and shift work*. New York: Spectrum, 1981, pp. 435-458.
- Haslam, D.R. Sleep loss, recovery sleep and military performance. *Ergonomics*. 1982, 25, 163-178.
- Heselgrave, R.J., & Angus, R.G. Sleep loss and sustained performance (NATO DRG Report DS/A/DS(83) 170). In *The Human as a limiting element in military systems*. Brussels: NATO Defense Research Group, 1983, pp. 61- 110.
- Holley, D.C. Effects of circadian rhythm phase alterations on physiological and psychological variables: Implications to pilot performance, an annotated bibliography (NASA-Ames Interchange #NCA2-0R675-005). July 15, 1980.
- Johnson, L.C. Sleep disturbance and performance (NHRC Report No. 79-19). San Diego: Naval Health Research Center, 1979.
- Klein, K-E., & Wegman, H.M. *Significance of circadian rhythms in aerospace operations*. AGARD Conference Proceeding No. 247. Neuilly-sur- Seine, France: NATO/AGARD, 1980.
- Krueger, G.P., Cardenaliz-Ortiz, L., & Loveless, C.A. Human performance in continuous/sustained operations and the demands of extended work/rest schedules: An annotated bibliography (USAMRDC Report No. WRAIR-BB-81-1). May 1985.
- Lubin, A., Hord, D.J., Tracy, M.L., & Johnson, L.C. Effects of exercise, bedrest and napping on performance decrement during 40 hours. *Psychophysiology*, 1976, 13, 334-339.
- Lumley, M., Roehrs, T., Zorich, F., Lamphere, J., & Roth, T. The alerting effect of naps in sleep-deprived subjects. *Psychophysiology*. 1986, 23, 403-408.

Fatigue

- Marshall, S.L.A. *Night drop: The American airborne invasion of Normandy*. Boston: Little, Brown, 1962.
- Mullaney, D.J., Kripke, D.F., Fleck, P.A., & Johnson, L.C. Sleep loss and nap effects on sustained continuous performance. *Psychophysiology*. 1983, 20, 643-651.
- Naitoh, P. Chronobiologic approach for optimizing human performance. In *Rhythmic Aspects of Behavior*, Hilday, N.J. Erlbaum, 1982, pp. 41- 103.
- Naitoh, P., Englund, C.E., & Ryman, D.H., Sleep management in sustained operations user's guide (NHRC Report No. 86-22). San Diego: Naval Health Research Center, 1986.
- Nicholson, A.N., & Stone, B.M., *Sleep and wakefulness handbook for medical officers*. AGARD Conference Processing No. 270(E). Neuilly-sur- Seine, France: NATO/AGARD, 1982.
- Nicholson, A.N., Stone, B.M., Borland, R.G. & Spencer, M.B., Adaptation to irregularity of rest and activity in sustained intensive air operations; Physiological and performance aspects. AGARD Conference Report No. 338. Neuilly-sur-Seine, France: NATO/AGARD, April 1983.
- Rayman, R.B. Aircrew health care maintenance. In DeHart, R.L. (Ed.), *Fundamentals of aerospace medicine*. Philadelphia: Lea & Febiger, 1985, pp. 412-414.
- Ryman, D.H., Naitoh, P., & Englund, C.E. Decrements in logical reasoning performance under conditions of sleep loss and physical exercise: The factor of sentence complexity (NHRC Report No. 85-20). San Diego: Naval Health Research Center, 1985.
- Tilley, A.J., & Wilkinson, R.T. The effects of restricted sleep regime on the composition of sleep and on performance. *Psychophysiology*, 1984, 21, 406-412.

CHAPTER 20

THERMAL STRESSES AND INJURIES

- Introduction
- Thermal Equilibrium
- Hypothermia
- Hyperthermia
- Indices of Thermal Stress
- References and Bibliography

Introduction

In his continuing attempt to master his environment, man has circumvented his phylogenetic heritage as a tropical mammal by developing a sophisticated technology which permits him to control the temperature, humidity, and pressure of his immediate surroundings in an almost routine manner. However, for the aircrewman, in-flight emergencies or enemy action remain ever present hazards, and a situation may develop almost instantaneously which may force him to survive the rigors of exposures to extremes of temperature or cold water immersion. Ground support personnel must frequently live and work under similar adverse environmental conditions, and maintenance of their functional effectiveness both ashore and afloat is an area of concern to the flight surgeon. Therefore, it is incumbent upon the flight surgeon to understand the various operational, clinical, and preventive medicine interrelationships involved in environmental thermal stress.

Man's response to environmental extremes of temperatures had been of interest prior to his early attempts to fly. His response to climate influenced his geographical migrations and cultural development. It was realized even before commencement of modern tropical and polar explorations and subsequent naval operations that an individual's ability to lead a healthy and productive life in such environments was problematic. Although it is nearly impossible to divorce completely the physiological effect of temperature extremes from their psychological effect, this chapter will consider primarily the former.

Because all mammals are homeothermic organisms, maintenance of the internal body or "core" temperature within a minimal range of variation, independent of ambient temperature, is

the major factor responsible for the normal pattern of biochemical reactions in man. The biochemical reactions responsible for metabolism impose several requirements upon the mechanisms regulating body temperature. Since most biochemical reactions are effected through the action of enzymes, which are particularly sensitive to temperature change, a fall or rise of only a few degrees in core temperature may so retard metabolism that normal behavior is impossible and death may ensue. In the course of biochemical oxidation, heat is liberated, and unless provision is made for its dissipation, overheating of the body may occur. This could cause death as a result of irreversible damage to the various enzymatic systems and cells of the central nervous system. It is mandatory, therefore, that thermal equilibrium of the body be maintained.

Thermal Equilibrium

Thermal equilibrium is preserved by the body's ability as a whole to alter its rate of heat production and heat loss. Since body temperature is really a measure of heat content or storage, a fall in temperature indicates a decrease, while a rise denotes an increase, in the total heat content of the body. Although the core temperature varies normally over a range of only a single degree, the variation in temperature of the exposed portions of the body reflects its continual effort to achieve equilibrium. First, the rate of heat production and then, the rate of loss are altered by environmental or physiological changes. A normal sized, unclothed man at rest in a postabsorptive state can, with minimum body effort, reach thermal equilibrium at a room temperature of 86°F (30°C). Under such conditions, the individual retains only that amount of heat formed by his basic metabolic processes which comprise normal storage. He loses the remainder to the environment without utilization of any of his reserve mechanisms of heat loss. The preceding example is only one instance of countless states of thermal equilibrium. Its significance lies in the fact that no reserve mechanisms of heat production or heat loss are required to achieve equilibrium. Under different conditions of clothing, activity, or environment, additional physiological adjustments would be needed to maintain an equivalent state.

Another expression of thermal equilibrium has been designated as the "comfort zone." The comfort zone may be grossly defined as the set of environmental conditions which causes neither sweating nor shivering. A more precise specification is possible through reference to the Effective Temperature (ET) Scale, which has become an accepted index of environmental comfort.

A scale of effective temperature may be presented as a family of curves formed by a plot of all combinations of relative humidity and temperature that yield the same subjective sensation of temperature (Figure 20-1). It is generally agreed that the optimum comfort range for persons wearing normal indoor clothing is +65° ET to +73° ET. As can be seen, this corresponds roughly to a temperature range between +70°F and +80°F with relative humidity between 40

Thermal Stresses and Injuries

and 60 percent. Although in practice the Effective Temperature Scale has been found workable, it should be noted that the stated comfort range will be altered as a function of any variation in amount of clothing worn, level of physical activity, and with the introduction of the factor of air movement.

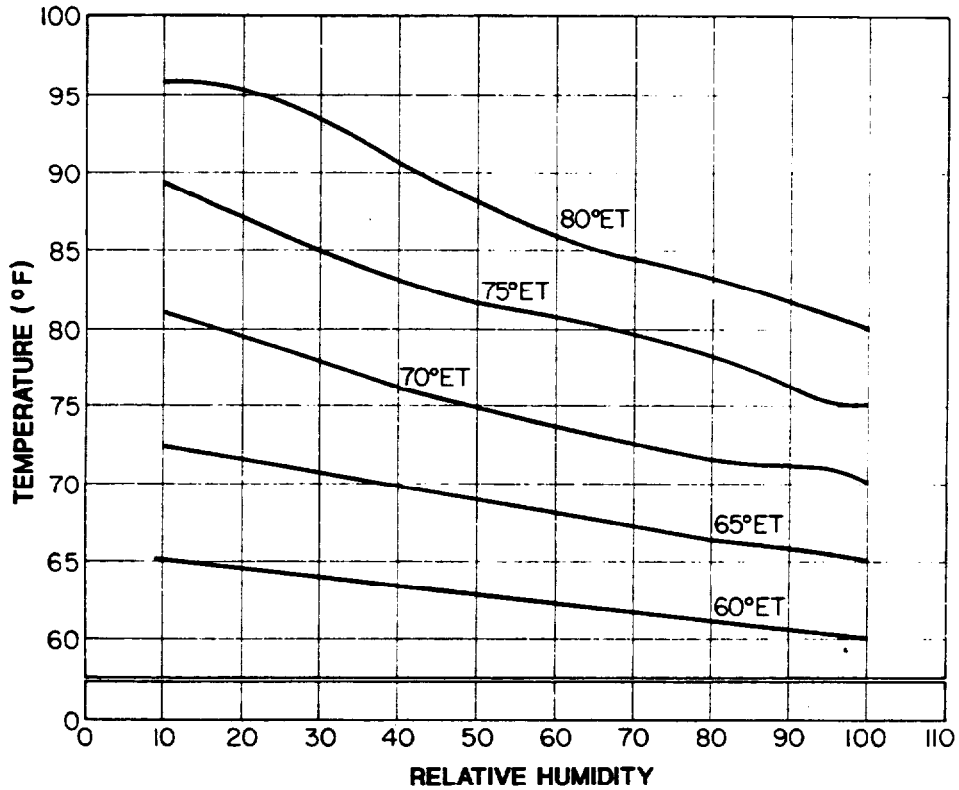

Figure 20-1. Scale of effective temperature.

Heat Transfer

Heat is transferred to and from the body by several different physical processes - radiation, conduction and convection, and the vaporization of water.

Within the body, heat is transferred from the core to the shell or skin surface primarily by conduction. The agent of transport is the circulating blood. Therefore, thermal regulation is closely

related to the regulation of peripheral circulation through the cutaneous vascular bed, particularly of the extremities, since they represent about 65 percent of the total body surface. At certain times, as much as ten percent of the total blood volume of the body may be located in the skin, within a surface layer only two millimeters thick (Krog, 1974). The mechanisms by which circulatory control is accomplished either to preserve or dissipate heat are many and complex. These mechanisms are mediated both centrally and locally and include vascular dilation and constriction, arteriovenous shunts, cold-induced vasodilation, counter-current exchange, and cold adaptation. The existence, as well as the relative importance, of some of these mechanisms, however, has been challenged.

Radiation. Radiation is the transfer of heat from the surface of one object to another without physical contact between the two. The magnitude of heat loss in man is directly dependent on skin surface area and the average temperature gradient between the skin and surrounding objects. The heat loss from radiation varies widely with environmental conditions. In a temperate climate, a resting individual, wearing ordinary clothes, loses about 60 percent of his heat production by radiation. At a temperature of 90°F, this loss may drop to zero. Conversely, at subzero temperatures, heat loss by radiation may reach levels higher than 60 percent.

Conduction and Convection. Conduction and convection are less important methods of heat loss in temperate climates but assume major roles in polar climates. By conduction, the cold air in immediate contact with the skin is warmed; the heated molecules move away, and cooler ones approach to take their places. These in turn are warmed, and the process perpetuates itself. The air movements constitute convection currents. Any process, such as wind, which tends to increase the rate of movement of the ambient air relative to the skin surface intensifies heat loss. The phenomenon has been incorporated into the concept of windchill by Siple and Passel (1945). A unit of windchill is defined as the amount of heat that would be lost in an hour from a square meter of exposed skin surface which has a normal temperature of 91.4°F. Given a hypothetical situation wherein the wind velocity is 20 miles per hour and the temperature is 34°F, reference to the windchill chart (Figure 20-2) discloses that at the given wind and temperature conditions of the hypothetical situation, the rate of cooling of all exposed flesh is the same as at minus 38°F with no wind. It is easily concluded that under the climatic conditions observed in polar operations, conduction and convection are significant causes of heat loss and potential contributory factors in the causation of cold injuries.

Heat loss by conduction also occurs from transfer of heat to tidal air as it is warmed in the respiratory passages and lungs, to water and foodstuffs taken into the gastrointestinal tract, and to waste materials (urine and feces) as they are eliminated.

Thermal Stresses and Injuries

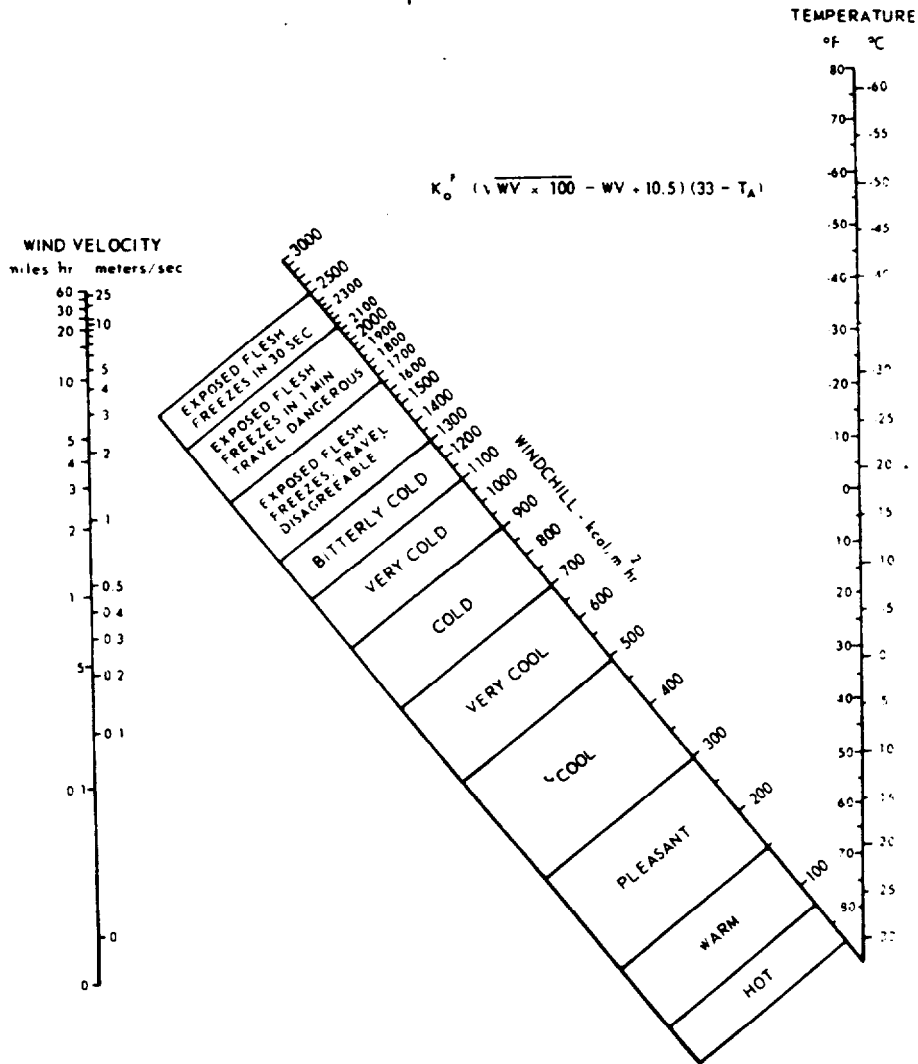

Figure 20-2. Windchill nomogram (after Blockley, 1964; adapted from Sipple & Passel, 1945).

Vaporization of Water. Vaporization of water removes heat from the skin surface and the moist mucous membranes of the respiratory epithelium. When one gram of water is converted into water vapor, 0.58 kilocalories of heat must be supplied from the surroundings for the conversion to occur. Although the actual amount of heat loss depends on the ambient relative humidity, in Antarctica, where humidity is very low, respiration alone may account for ten percent (375 kcal) of an individual's total daily heat loss. Insensible perspiration, as is shown in a later section, accounts for an additional loss of about 400 kcal.

Loss of heat by vaporization of perspiration from eccrine sweat glands may account for a large part of the total heat loss at temperatures of 93°F to 95°F, or above, but in polar climates, it assumes importance only under certain clothing conditions which will be discussed later.

It can be seen, then, that loss of heat from the body occurs primarily at two surfaces, the skin and the epithelium of the respiratory system. Under constant environmental conditions, the amount of heat loss depends upon surface area, temperature gradient, humidity, vapor pressure gradient, and the rate of airflow over the surface.

Heat Regulation in Cold Environments

Physiological Mechanisms to Diminish Heat Loss. Some of the physiological methods used to diminish heat loss in lower mammals are unsuitable or impractical for man. Such procedures as rolling up into a ball and thereby markedly decreasing the area of exposed skin, or diminishing heat loss from vaporization of water at respiratory surfaces by cessation of panting, have little application to human beings.

Since approximately 80 to 85 percent of heat loss occurs from the body surface, any reduction in skin temperature should conserve body heat. Changes in the temperature of body surfaces are mediated through the activity of three physiological mechanisms. Unfortunately, one of the three mechanisms, although of some value in retaining body heat, is of greater importance when heat dissipation is desired.

The first mechanism depends upon the means by which heat is transported from the depths to the surface of the body. Blood is 80 percent water by volume; because of the water's high heat capacity, circulating blood is the primary source of heat transfer to the body surface. The total amount of heat brought to a given area is a function of the rate of blood flow through the area. If the rate of flow is retarded by local constriction of the superficial arterioles, the total heat transfer from blood to skin tends to be small and the skin remains cool, thereby decreasing the temperature gradient between it and the surrounding cold air. Although this physiological mechanism is an important means of heat conservation, a certain minimum blood flow through the skin must be maintained to prevent localized anoxia and cellular death.

The second mechanism is dependent on the phenomenon of horripilation, or erection of body hair, which increases the thickness of the layer of nonconducting air entrapped between the hairs. Since surface temperature depends upon the ease with which heat is transferred from the body to the environment, horripilation affords a satisfactory method for retarding conduction by reducing the temperature gradient between the skin and environment even though the skin temperature

Thermal Stresses and Injuries

may remain at a high level. Due to evolutionary processes, man is poorly equipped to take advantage of horripilation. Nevertheless, he utilizes the principle by substituting a different insulating material, clothing, for the hair he lacks. A single layer of clothing limits heat exchange by replacing the single temperature gradient between a nude subject and his environment with three such gradients. One of these three exists between the skin and the inner surface of the insulation, another exists between the outer surface of the insulation and the environment, and the third gradient is found between the inner and outer surfaces of the insulation. The effectiveness of clothing in decreasing heat loss is proportional to the magnitude of this third gradient, which in turn depends upon the nature and thickness of the nonconducting substance.

A third mechanism modifies the temperature of body surfaces by varying the amount of moisture available for vaporization. Since insensible heat loss due to perspiration is not subject to wide variation in cold climates, the primary value of this mechanism is in the dissipation of body heat rather than its retention.

Heat Production. When heat loss exceeds heat production in spite of utilization of the previously discussed physiological mechanisms, the body, in an effort to regain thermal equilibrium, increases heat production. Heat production is essentially chemical in nature and is developed from at least two different sources. When body temperature decreases in a resting human exposed to cold, involuntary muscular contractions (shivering) ensue. Since only 25 percent of the energy liberated by chemical changes in contracting muscle is converted to work, heat production is equivalent to three or four times that of the muscle at rest. Even more efficient in heat production than isotonic involuntary exercise is voluntary isometric exercise (contraction of both extensors and flexors simultaneously) which converts all of the energy produced to heat.

Another source of heat production which does not involve skeletal muscle contractions has been demonstrated by various investigators in animals. Small experimental animals like the rat are able to vary their rate of heat production within several hours by some mechanism in which the hormones of the thyroid gland, the adrenal cortex, and possibly the adrenal medulla participate without any detectable change in either voluntary or involuntary muscular activity (Davis, 1963). This nonshivering thermogenesis is produced by increased tissue sensitivity to norepinephrine, and the small amount of subcapsular brown tissue plays an important role in this mechanism. Recent research suggests that other tissues' increased heat production in the cold acclimatized animal is mediated through an intermediate mechanism in the brown fat tissue. Although Davis (1963) suggested that nonshivering thermogenesis also exists in man, man has no brown fat tissue, and nonshivering thermogenesis does not seem to occur to any significant extent in mammals larger than the rabbit (Jansky, 1969).

Those regulatory responses discussed above can succeed in maintaining thermal balance for hours within the compensable zone. Figure 20-3 shows the approximate limits of the compensable zones on both sides of the comfort zone. When temperatures fall below the compensable zone for cold tolerance, thermoregulation fails and extraneous methods must be utilized to maintain thermal balance.

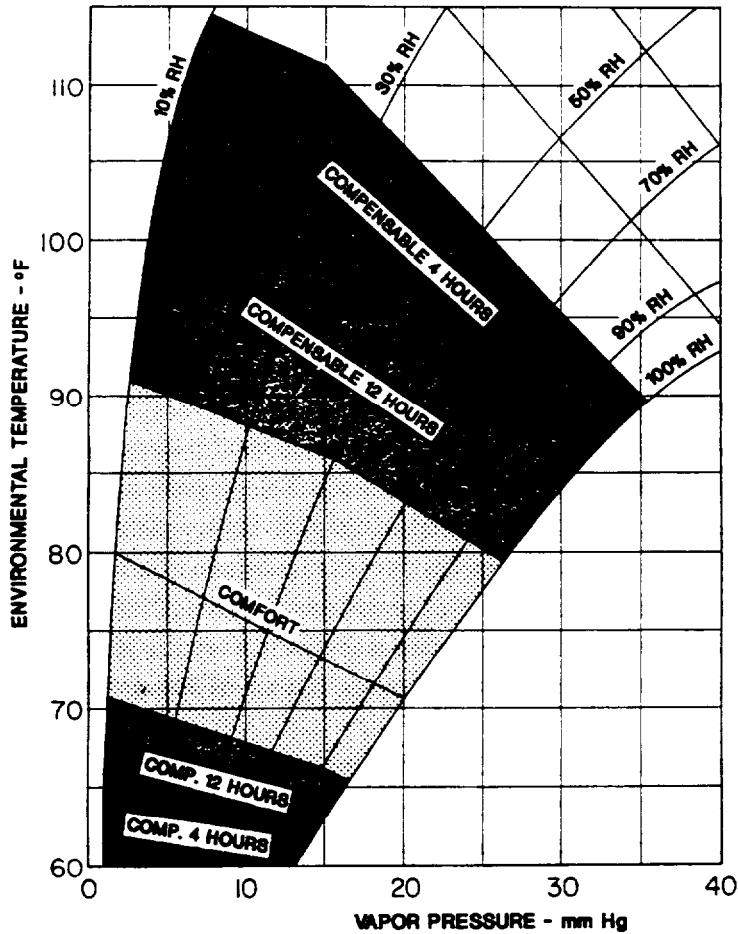

Figure 20-3. Representation of comfort zone and compensable zones (Webb, 1961).

Heat Regulation in Warm Environments

Physiological Mechanisms. As the body becomes heated, whether it is from exposure to a high temperature environment, physiological exercise, or a combination of both, superficial vasodila-

Thermal Stresses and Injuries

tion occurs, thereby increasing blood flow to the skin. This allows additional heat to be lost primarily by convection and radiation. Furthermore, heat is lost through insensible perspiration and respiration. When the body becomes heated beyond the limits of the comfort range, these processes are insufficient to maintain thermal equilibrium.

A second response to heat exposure is an increased rate of excretion by the eccrine glands. Through the evaporation of water produced by sweating, a large increase in the rate of heat loss can be realized. Although the body can produce sweat at a high rate, evaporation heat loss is limited by the physical process of evaporation, which, in turn, depends upon skin temperature, water vapor pressure gradient, and movement of the air surrounding the individual. The vapor pressure gradient is defined as the difference between the water vapor pressure at the skin and in the surrounding air.

Effects of Clothing. Thermal comfort and stability are modified considerably by the clothing an individual wears. With suitable clothing, a person can achieve a level of comfort and survival over a much greater range of environmental temperatures than those shown in Figure 20-3.

Heat transfer through clothing is a function of the thermal resistance of the clothing and the temperature and humidity differential between the inner and outer surfaces. Thermal resistance of clothing is expressed in terms of "clo" units. One clo is defined as the equivalent to normal indoor clothing and is that clothing insulation required to keep a resting or sitting man with a metabolism of 50 Kcal per square meter per hour indefinitely comfortable in an environment of 69.8 °F (21 °C) with an air movement of 20 feet per minute, and with a relative humidity of less than 50 percent (Kerslake, 1965). The insulation value of clothing is a function of the air trapped between its fibers and is roughly equal to four clo per inch thickness of fabric.

The biophysics of clothing has become singularly significant in recent years because it uses an interdisciplinary approach (physiology, psychology, physics, clothing design, and textile science) which relates human work efficiency and comfort to a specific task in a particular environment. Prior to this realization, the physiologist was consulted for information about the man, and the climatologist was sought out for knowledge of the environment. Little was known about the physics of how clothing materials interacted with each other or with the complex man-clothing-environment system. Most experimental measurements utilized "steady state" conditions for simplicity and the reduction of variables. Utilization of the biophysical approach should result in an end product clothing system in which man, environment, and clothing are united into a functional and comfortable whole.

In a cold environment, an individual frequently finds himself wearing more insulation than he needs during work and less than he needs at rest. This is readily explained by considering the

biophysics of the situation. For maintenance of thermal equilibrium in any given environment, the optimum insulation is five to six times as much at rest as at work. The problem, then, is to design clothing which optimizes the balance between static and dynamic insulating efficiencies. Specifically, the rate of heat loss must be minimized when activity level is low and increased when activity level rises.

Primary functions of protective clothing are to ensure adequate ventilation for the escape of both insensible and sensible perspiration, and to provide, around the body, an insulating zone of dead airspace which is compartmentalized in sufficiently small pockets so that currents of air will not be set up by movements of the body and thus disperse heat.

Polar explorers have cautioned repeatedly against the danger of sweating profusely because during later periods of diminished activity, excessive heat loss occurs when the vaporized perspiration condenses on the cold outer cloth, thereby permitting direct heat transfer by conduction. Because retention of vaporized perspiration in clothing diminishes the effectiveness of the sweat mechanism in cooling the skin surface, increased production of perspiration ensues and a potentially dangerous situation develops.

Conversely, in hot environments, clothes become a barrier to the evaporation of perspiration from the skin because sweat evaporated from wet clothing is much less effective in removing heat from the body than moisture evaporated directly from the skin.

Figure 20-4 illustrates the interaction of clothing insulation, activity, and ambient temperature in the maintenance of thermal balance.

Hypothermia

When heat loss exceeds heat production, hypothermic injury may develop. Hypothermia is classified as general or local, depending on whether the injury affects the individual as a whole or affects only a particular part of the body.

General Hypothermia

Accidental general hypothermia may result from total or partial immersion in cold water or from exposure to cold ambient air temperatures alone. It is the most frequent cold injury seen in aviation medical practice afloat. Almost four-fifths of the world's surface is covered with water, and apart from the equatorial regions, the temperatures of the world's seas are substantially below body temperature. Deck personnel and particularly aircrewmen who fly above these waters

Thermal Stresses and Injuries

are at risk of being placed precipitously into the cold sea and sustaining the physiological insults imposed by accidental immersion. Local cold injury is less of a threat to deck and shore station crews who must work outside in very cold weather or under conditions of a high windchill index. They are usually prepared and adequately clothed to resist the deleterious effects of exposure to cold air.

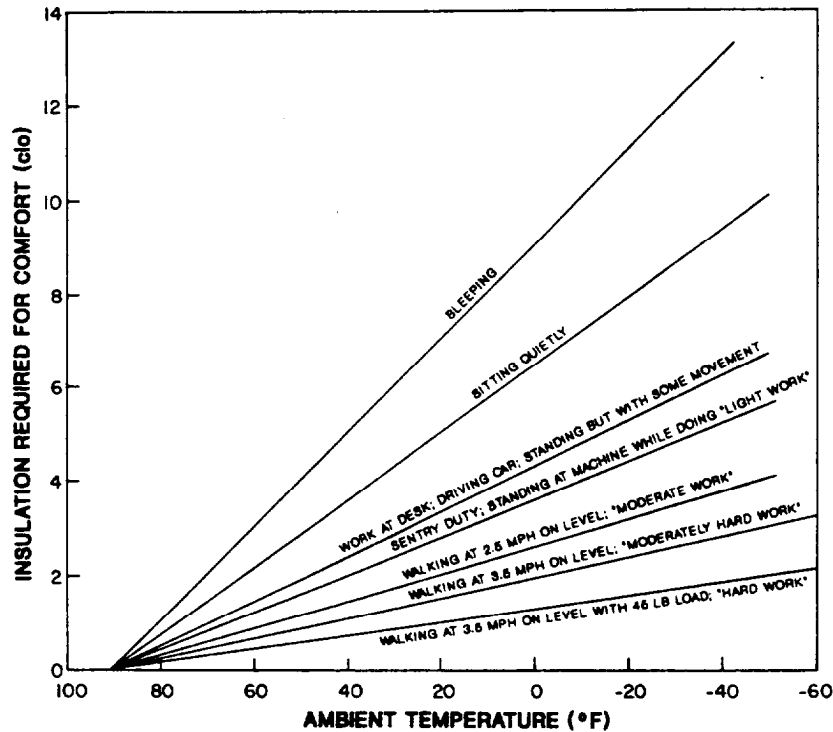

Figure 20-4. Prediction of the total insulation required for prolonged comfort at various activities in the shade as a function of ambient temperature (Morgan, Cook, Chapanis, & Lund, 1963).

Immersion in cold water is different from exposure to cold air because of two physical properties of water:

1. The thermal conductivity of water is approximately 26 times greater than that of air. Therefore, during immersion, heat is conducted away from the body at 26 times the rate it would be in air.

2. Water has a specific heat approximately 1,000 times that of air. Therefore, each cubic centimeter of water in contact with the skin can extract and hold 1,000 times more heat from the body than a comparable volume of air for any given increase in temperature.

The rate of heat loss from the immersed body is, therefore, a function of the temperature differential between the skin and the water immediately adjacent to it and the rate of heat transfer from the body core to the skin.

Etiology. The most important factors in determining the rate of onset and the depth of hypothermia are the water temperature and duration of immersion. In 1946, Molnar, in his classical paper, emphasized the relationship between survival times and water temperatures below 59°F (15°C). Immersion in water at 28°F to 35°F (-2.2°C to + 1.7°C) may result in unconsciousness in five to seven minutes and in death in ten to twenty minutes. The ungloved hand becomes useless in one to five minutes due to loss of tactile sensation. Figure 20-5 illustrates the effect of variations in water temperature on the rate of fall of body temperature.

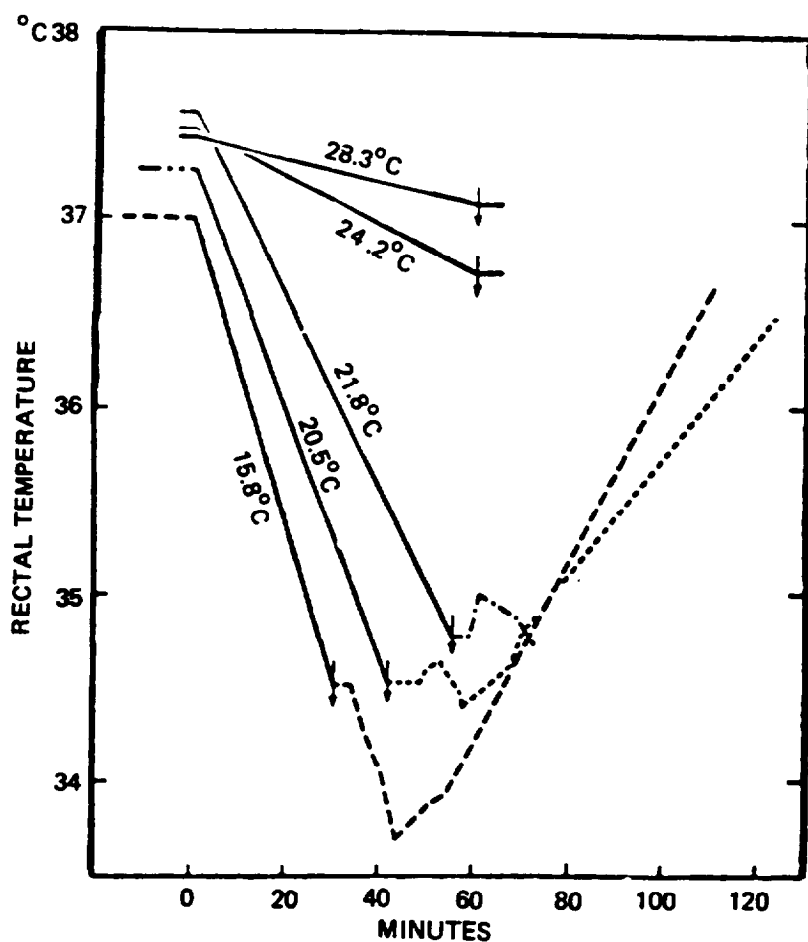

Figure 20-5. Rectal temperature in an experimental subject after swimming in water at various temperatures. Time 0 indicates water entry; down arrow indicates water exit (Golden, 1974).

Thermal Stresses and Injuries

Another factor influencing the rate of onset of hypothermia is the amount of water movement relative to the surface of the immersed body. Currents, turbulence, and body movement each cause the water molecules next to the body surface to be exchanged more frequently, thereby promoting increased heat loss due to conduction and convection. In water at 41°F (5°C) for twelve minutes, it has been found that moderate work doubled the rate at which rectal temperature fell because of increased blood circulation. Working as hard as possible only slightly decreased the rate of temperature loss at this temperature. Collis (1976) determined that survival time could be increased by about one-third by holding still in the water instead of swimming. Infrared thermograms taken of individuals who had remained nearly motionless while immersed demonstrated the areas of greatest heat loss to be the inguinal and thoracoaxillary areas. Collis developed a position called HELP (heat escape lessening posture) for survivors in the water by themselves in which the knees are drawn up to the chest and the arms are clasped together at the chest. Survival time in 50°F (10°C) water proved to be four hours, or double the survival time of a swimmer in the same temperature water. Another significant finding from the series of 5000 immersions in water with temperatures ranging from 39°F (4°C) to 59°F (15°C) was that the drownproofing technique of flotation resulted in a cooling rate 50 percent faster than that observed in subjects treading water with the head above the surface.

A factor which may influence the rate of onset of hypothermia is the presence of body fat. Keatinge (1960) described a linear relationship between fall in rectal temperature and the reciprocal of the mean skinfold thickness in men. It might be expected then that, all other factors being equal, females, who tend to have a higher total percentage of body fat than males of similar height and weight, should have a slower cooling rate on immersion than males of similar height and weight. Golden and Hervey (1972) demonstrated that this is not the case (Table 20-1) and that the overall rate of cooling of unclothed individuals depends on a complex interplay of many factors, notably heat production, body size, and fat insulation.

The importance of protective clothing as a factor in the etiology of hypothermia has been demonstrated experimentally by many investigators and is confirmed by accounts of survivors. The mechanism of protection at its most basic level, and with only a single layer of clothing, is to reduce the rate of exchange of the water molecules immediately adjacent to the skin.

Physiology of Immersion Hypothermia. In an excellent review article, Golden (1974) summarized the physiological changes seen as a result of immersion hypothermia. A precise understanding of the physiological changes in man is hampered by lack of hard data. The majority of the literature describes either the results of experimentally induced, relatively mild states of hypothermia or anesthetic hypothermia in which shivering was abolished and respiration controlled. With the exception of the Dachau experiments, most case studies relate instances of

hypothermia which had a relatively long duration of onset. Nevertheless, the understanding of physiological mechanisms in man has been extended by cautious extrapolation from experimental findings in animals.

Table 20-1

Percentage Skin Fold Thickness and Mean Rates of Cooling of Mixed Male and Female Subjects Immersed in Water at 9°C

<i>Subject</i>	<i>Sex</i>	<i>% Fat (skin fold thickness)</i>	<i>Subject</i>	<i>Mean cooling rate °C/hour</i>
Wendy	F	30	Andrew	10.7
Christine	F	20	Christine	9.1
Brenda	F	18	Brenda	5.6
Stewart	M	17	Tim	5.1
Ian	M	16	Will	4.4
Tim	M	14	Stewart	4.0
Will	M	14	Ian	3.1
Andrew	M	9	Wendy	2.3

(Golden & Hervey, 1972, published by permission of Cambridge University Press)

Metabolism. Immediately following cold water immersion, the body attempts to maintain its thermal integrity, but the rate of heat loss exceeds even the most violent efforts of the body to increase metabolic heat production through exercise. Involuntary shivering reaches a maximum at a core temperature of 95°F (35°C), but it declines thereafter to be replaced by a rigidity of muscles during the range of 91.4°F to 86°F (33°C to 30°C), which, in turn, is abolished around 80.6°F (27°C). An extrapolation from animal data would indicate that the relationship of oxygen consumption and body temperature is almost linear, and in dogs, oxygen consumption at 20°C was only 15 percent of normal. Since oxygen consumption in man is largely dependent on the shivering response, all evidence suggests that the increase in metabolic rate with cooling does not increase below a core temperature of 95°F (35°C).

Thermal Stresses and Injuries

The hyperglycemia resulting from hypothermia was first described by Claude Bernard. It was also observed in the Dachau experiments in which it was found that the blood sugar level was a mirror image of the rectal temperature. In the presence of shivering, blood glucose levels rise if there is an ample supply of carbohydrates. But as metabolism declines with decreasing body temperature, glucose utilization diminishes, and the early hyperglycemia continues. Where there is no shivering during cooling, such as in anesthesia, the blood glucose level is maintained or decreased. Therefore, in an individual whose hypothermic state was rapidly induced (acute), hyperglycemia should be observed, while in those individuals who developed hypothermia slowly (chronic) or while expending energy at high rates (subacute), the blood sugar level should be normal or subnormal. At temperatures below 86°F (30°C), glucose is metabolized slowly if at all, and insulin's effect on glucose transport across the cell membrane is significantly impaired. There is an immediate significant increase of free fatty acids in response to cold exposure which is still demonstrable eight hours after exposure. This suggests that lipids rather than glucose are the preferred source of energy in hypothermia.

Respiratory System. Hyperventilation with respiratory rates of 60 to 70 per minute is seen as a result of the initial shock of entry into cold water. There is a marked reduction in end tidal PCO₂, but it gradually returns to a little above the original level. This initial hyperventilation results in a reduction of arterial CO₂ which causes a dramatic rise in pH, but as blood temperature falls, CO₂ solubility increases and the arterial pH, falls. During rewarming, this acidosis, which is due in part to a metabolic component, may intensify, and the pH may fall as low as 7.1. The shift to the left of the oxygen dissociation curve resulting from the decrease in temperature is counteracted in part by a shift to the right due to lowering of pH. Respiration becomes progressively depressed as hypothermia deepens, and at near lethal core temperatures, it is extremely difficult to detect.

Cardiovascular System. The cause of death in hypothermia is almost always cardiac in origin. There is an initial stimulatory phase during which cardiac rate increases dramatically and central venous pressure rises. During this period, a marked peripheral vasoconstriction occurs. As the hypothermic condition deepens, cardiac rate decreases due to a direct effect of cold on the pacemaker, and cardiac output decreases as a direct consequence. Duration of systole increases, and the refractory period of the atrioventricular bundle is increased.

Arrhythmias are common in hypothermia. Extrasystoles are commonly seen on cold water entry. Atrial fibrillation appears to be more a feature of acute hypothermia and has been described in Dachau victims, World War II immersion survivors, in surgical patients with induced hypothermia, and even in an English Channel swimmer. Atrial fibrillation usually occurs at a body temperature of 91°F (33°C). As temperature falls to 82.4°F to 77°F (28°C to 25°C), there is a sharp increase in the incidence of ventricular arrhythmias, ectopic beats, and A-V dissociation,

and if the heart is mechanically stimulated at these temperatures, development of ventricular fibrillation is likely to occur.

In humans, death due to cardiac arrest appears to occur between 78.8°F and 75.2°F (26°C to 24°C); however, there are documented cases of accidental hypothermia victims surviving core temperatures of 64.4° (18°C). The nature of terminal cardiac arrest has not been precisely described. Extrapolations from animal experiments would suggest that when the heart is not mechanically stimulated, arrest is due to simple asystole, but when irritation occurs, ventricular fibrillation is the cause of death.

Other cardiovascular physiological changes include an increase in stroke volume but a reduction in cardiac output due to the slowing in rate. Central venous pressure increases; blood pressure falls, and there is a progressive reduction in total peripheral resistance at temperatures below 86°F (30°C). Although coronary blood flow is reduced, it is sufficient for the needs of the hypothermic myocardium. Peripherally, the initial cold-induced vasoconstriction may be replaced by cold-induced vasodilation on immersion in water below 50°F (10°C). This is thought to be due to a direct effect of the cold on the smooth muscles of the vessels.

Electrocardiographic findings consist characteristically of bradycardia and increased conduction time with concomitant prolongation of the P-R., QRS, and Q-T intervals, and S-T deviations both upwards and downwards with a flattening or inversion of the T-wave. In profound cases of hypothermia, there is also development of a "J-wave" (Osborne wave), which is a positive deflection at the junction of the QRS and S-T segments. Figure 20-6 shows a typical J-wave in an electrocardiogram of a six year-old girl who was treated by Golden (1974) for hypothermia with a rectal temperature of 76.3°F (24.6°C). A marked increase in blood viscosity with sludging of red cells is also seen. Platelets markedly decrease and clotting time is prolonged.

Kidneys. A marked cold diuresis occurs in the early stages of hypothermia as a result of the increased central venous pressure and its depressant effect on the secretion of antidiuretic hormone. As the hypothermia progresses and blood pressure falls, the glomerular filtration rate is reduced. But, due to impairment of the tubular transport mechanism, a higher percentage of the filtrate is excreted, carrying with it a proportionate amount of the electrolytes which are normally interchanged in this region. There is some evidence of lipid accumulation in the distal tubules due to exposure to the cold, and renal failure is a frequent complication of chronic hypothermia.

Central Nervous System. As brain temperature falls, cerebral activity becomes impaired. Amnesia is reported to occur at temperatures below 93.2°F (34°C). When core temperature falls below 91.4°F (33°C), the individual becomes semiconscious, and introversion and apathy are

Thermal Stresses and Injuries

seen. Consciousness generally seems to be lost or severely impaired at rectal temperatures of 87.8°F to 84.2°F (31°C to 29°C). Electroencephalogram changes appear as the body temperature falls between 96.8°F and 89.6°F (36°C to 32°C). These changes consist of decrease in amplitude of the potentials in the occipital areas first, followed later by changes in the parietal and frontal areas. At about 86°F (30°C), large delta waves appear in the frontal area; the electrical activity then declines until between 68°F and 64.4°F (20°C to 18°C) when no potentials can be recorded. As temperature continues to fall, muscle reflex activity becomes increasingly more difficult to elicit. The pupils begin to dilate at about a core temperature of 91.4°F (33°C) and are usually fully dilated and unresponsive to light when the core temperature has fallen to 86°F (30°C).

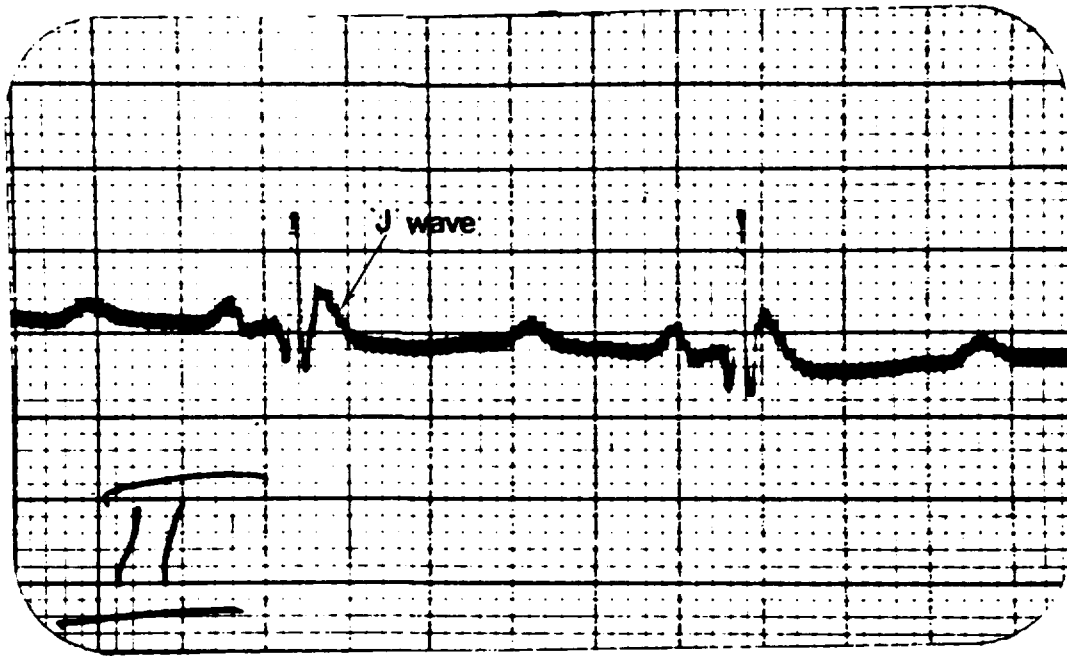

Figure 20-6. ECG (Lead II) trace taken from 6-year-old female with a rectal temperature of 24.6°C (Golden, 1974).

"Afterdrop." Nearly all immersion hypothermia victims experience a deterioration in their condition manifested by an "afterdrop" or paradoxical fall in their core temperature once they have been removed from the cold water. This phenomenon has been described by many investigators and is attributed to a continuation or progression of the rate of change of body temperature for an additional 10 to 20 minutes after removal from the water. It is thought to be caused by returning cooled blood to the core from the reviving peripheral circulation. In the Dachau experiments, the afterdrop averaged 1.9°C but did reach 4°C. Coincidental with the afterdrop in temperature, there is likely to be a fall in pH and some degree of hypotension. But in

hypothermia due to immersion, there is usually insufficient time for renal compensation of the abnormal fluid and electrolyte changes which take place. Even though a grossly abnormal physiological condition may exist, it is primarily a thermal disturbance, and it is that thermal disturbance which must be promptly treated.

Diagnosis. Untreated accidental hypothermia carries an extremely high mortality rate. Hypothermia should be considered in the differential diagnosis of all drowning victims as well as in the less circumstantially obvious cases of unconsciousness due to alcohol or drug intoxication and trauma. The diagnosis may easily be confirmed by use of a special low-reading thermometer or thermocouple. In the absence of a special thermometer, a reasonably accurate assessment of the core temperature may be estimated from the clinical signs and symptoms whose physiological basis has been described in the preceding section'. These signs and symptoms and their relationship to body temperature are depicted in Figure 20-7 (Golden, 1973).

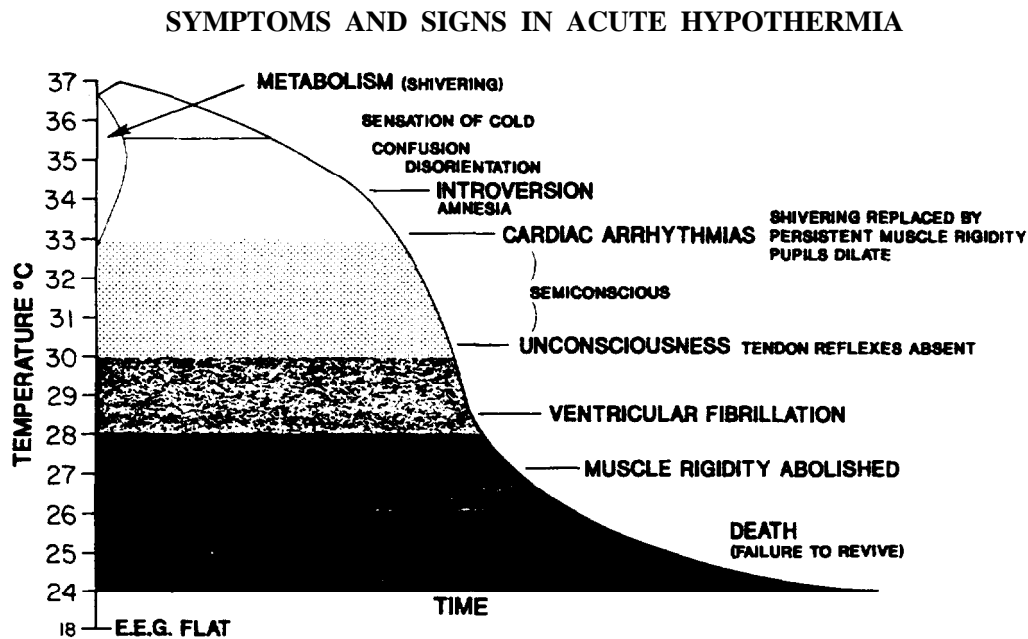

Figure 20-7. This curve represents the behavior of body temperature during cold water immersion with associated signs and symptoms encountered at various body temperatures (Golden, 1973, reproduced by permission of the Editor of the *Proceedings of the Royal Society of Medicine*).

Thermal Stresses and Injuries

The usual signs of “clinical death” are extremely unreliable in victims of hypothermia. Below 80.6°F (27°C), all evidence of life is extremely difficult to detect. At these temperatures, there is an intense bradycardia and respiratory depression coupled with hypotension and extensive peripheral vasoconstriction, all tending to make it difficult to palpate a peripheral pulse or hear a heartbeat. Muscles are extremely flaccid and the pupils are widely dilated. Even cardiac standstill demonstrated electrocardiographically is insufficient evidence of death since the literature contains documented cases of cardiac arrest of durations up to one hour in hypothermic victims who were subsequently revived. Therefore, it is imperative that resuscitation efforts begin at once.

Treatment. The goal of therapy is to restore to normal the core temperature of accidental hypothermic victims as expeditiously and safely as possible. The treatment of immersion hypothermia may be divided into preventive, first-aid, and definitive segments. The most effective treatment is undoubtedly prevention, and the issuance of protective clothing and personal survival gear to aircrew members together with instructions in their proper use may well reduce the incidence of immersion hypothermia cases. In spite of these precautions, personnel aboard ship may be swept over the side; or adequately clothed and outfitted downed crew members may exceed designed time limitations for clothing protection in cold weather, and once rescued, treatment may be required.

Treatment will depend on the conditions under which the rescue was executed and the immediate facilities available. Survivors who are rational and possess motor function, although shivering dramatically, usually do not require treatment beyond safeguarding against further heat loss. If facilities are available for rewarming, they should be utilized. But, if the survivor is well insulated and protected from further heat loss, metabolic heat produced by his own shivering will rewarm him in time. Hot, sweet drinks, rest, and avoidance of an overheated environment are recommended.

The following paragraphs discuss the treatment of the semiconscious, unconscious, or apparently dead victim.

First-Aid Treatment. The primary goals of the first-aid treatment are to prevent further loss of heat and to maintain life until the survivor can be transported to a definitive treatment center. If the distance to be traveled requires more than 20 to 30 minutes, attempts should be made to provide definitive treatment on the spot.

1. Immediately remove the victim from the hypothermia-inducing environment.
2. Handle the patient gently in order to minimize the likelihood of the development of ventricular fibrillation in the sensitized myocardium. Do not attempt closed-chest cardiac resuscita-

tion. Do not attempt to undress the patient because the manipulative efforts required to remove the wet clothing may be detrimental. In mild cases, wet clothing may be removed and replaced with dry clothes or blankets.

3. Maintain a clear airway. The patient should be placed in a slightly head-down position to combat hypotension. Semiconscious patients should be transported in the same manner in anticipation of unconsciousness which may develop as a result of the "afterdrop."

4. Further heat loss should be prevented by wrapping the patient in blankets, enclosing the body in a large polyethylene bag, and insulating him from the ground. No attempt should be made at this time to rewarm the patient actively by using hot water bottles, catalytic warmers, or any other means.

5. Administer oxygen by oronasal mask.

The risk of developing ventricular fibrillation in the cold-sensitized myocardium must be emphasized. Profound hypothermia mimics cardiac arrest, and attempts to restore cardiac activity by closed-chest cardiac resuscitation are likely to produce ventricular fibrillation. Furthermore, should the heart be in arrest, any effort to restore normal rhythm is unlikely to succeed until the myocardium begins to rewarm, when a spontaneous reversion to normal rhythm may occur.

Definitive Treatment. Restoration of core temperature to normal levels may be accomplished by using either of two approaches, broadly categorized as external and internal. In the external method, the surface is rewarmed in advance of the core, and heat is transferred from the shell to the inner body by direct conduction and by convection of the circulating blood. External rewarming may be an active process in which heat is applied to the body by immersion in 104°F (44°C) water, heating pads, hot water bottles, or heat cradles. Or, external rewarming may be passive in which case no heat is applied to the patient. Blankets may or may not be used to cover the patient who is allowed to achieve, without active assistance, an equilibrium state with ambient room temperature. In contrast to external rewarming, internal rewarming refers to raising the core temperature in advance of the shell. Although case reports are few in number, success has been reported by using such internal techniques as peritoneal lavage with solutions warmed to 104°F (40°C), placing the patient on a heart-lung machine, femoral artery bypass, and inhalation of warmed, water-saturated gases. Advantages cited for the internal rewarming method of treatment are the rapidity with which normothermia can be achieved, the more rapid return of cardiac output and the electrocardiogram toward normal, and the avoidance of "rewarming shock" or further drop in core temperature during early rewarming.

Thermal Stresses and Injuries

The method of rewarming selected as therapy by the attending flight surgeon will depend in part on facilities available, circumstances surrounding the immersion, condition of the patient, and the flight surgeon's familiarity with the various treatment modalities. In spite of the promise inherent in the new internal rewarming therapeutic approaches, rapid, active external rewarming probably remains the most successful and most easily performed treatment for the victim of immersion hypothermia. The following regime; is suggested for the shipboard flight surgeon with the understanding that it may differ from that available, or even desirable, in a Navy Regional Medical Center:

1. Handle the patient gently. If clothing must be removed, cut it off.
2. Rapidly rewarm the patient in a 106°F (41°C) water bath in which the water is agitated. A whirlpool bath is suitable for use aboard an attack carrier. For multiple cases or where a whirlpool is not available, a small life raft inflated near a source of hot water is a satisfactory substitute. An unconscious, unclothed patient may be exposed to water temperatures up to 112°F (44.5°C). Initially, the arms and legs should be kept out of the bath to delay the revival of the circulation in the tissue mass of this portion of the cold shell. This may reduce the work load on the cold myocardium and possibly reduce the magnitude of the "afterdrop."
3. Maintain a clear airway and administer 95 percent oxygen and five percent carbon dioxide via an oronasal mask to overcome the oxygen debt that occurs on rewarming. If at all possible, intubation should be avoided as it can produce ventricular fibrillation.
4. Closely monitor core temperature, vital signs, and electrocardiogram.
5. Start a central venous pressure monitor and draw blood for an immediate reading of pH, PCO₂, PO₂, and electrolytes, and then follow these parameters as an indication of treatment progress.
6. Be prepared to administer intravenous sodium bicarbonate warmed to 98.4°F (37°C) before transfusion.
7. Do not give antiarrhythmic drugs since they have little value at lowered body temperatures and may even precipitate ventricular fibrillation. Should ventricular fibrillation develop, it should be remembered that defibrillation is of little value when the cardiac temperature is below 82.4°F (28°C). If on rewarming sinus rhythm has not returned when deep body temperature reaches 86°F (30°C), then defibrillation should be attempted.

8. Leave the patient in the hot bath until he is subjectively warm. Then remove him and place him in a warmed bed. The patient should not be left in the hot bath until his temperature returns to normal levels because there is a tendency for the temperature to "overshoot" upon removal from the bath, and a subsequent difficulty in readjusting may be encountered.

Recovery from acute hypothermia is usually dramatically swift following rapid rewarming. Nevertheless, even after the patient revives, he should be treated as a total emergency and constantly monitored until his temperature returns to normal and he is ambulatory. Catastrophic arrhythmias have occasionally developed after it appears that the acid base balance and cardiovascular performance have returned to normal. The hypokalemia which is commonly seen in hypothermia, despite the usually associated acidosis, is probably secondary to the intracellular migration of potassium and should not be interpreted as requiring vigorous replacement.

The most commonly seen late complications of acute accidental immersion hypothermia are pneumonia, renal failure, and pancreatitis.

Local Hypothermia

Local hypothermic injury may be represented as a collection of traumatic conditions whose severity is characterized by a continuum of tissue damage ranging from the most mild, chilblains, to the most extensive, deep tissue freezing. The type of injury produced is a function of the temperature to which the body or its parts are exposed, the duration of exposure, and other concurrent environmental factors.

It is an accepted convention to divide injuries into "freezing" and "nonfreezing" types. Non-freezing cold injuries include chilblains and trench or immersion foot. Chilblains result from intermittent exposure to temperatures above freezing accompanied by high humidity. Chilblain is the only cold injury which is not militarily significant.

Trench Foot. Trench foot and immersion foot are indistinguishable with respect to cause, pathology, and treatment. Trench foot (immersion foot) results from prolonged exposure to wet, cold foot gear or outright immersion of the feet at temperatures usually below 50°F (10°C). At the upper range of temperatures, exposures of 12 hours or more will cause injury. Shorter durations of exposure at or near 32°F (0°C) will cause the same injury. Dependency or immobility of the feet aggravates and predisposes the development of the condition. Sailors in sea water or soldiers and marines with wet feet in trenches, rice paddies, or foxholes develop trench foot.

Warm water immersion injuries were described during military operations in Vietnam (Anderson, 1967). In these cases, the injury consisted of whitening or wrinkling of the skin and pain in

Thermal Stresses and Injuries

the feet after two days or more of water exposure. Additional exposure resulted in erythema on the weight-bearing surfaces and edema. Complete recovery occurred following proper foot care. In a seven to ten-day military operation in which continuous wet foot exposure occurred, Anderson found that about 30 percent of the troops required evacuation for immersion foot injury. This could have been prevented had the troops been able to dry their feet for six to eight hours per day with boots and socks off, but such is rarely possible in combat situations.

Recently, Hawryluk (1977) described military operations in a temperate climate over a 13-day period when the minimum temperatures ranged between 28 and 43°F with a chill factor between 8°F and 41°F. Cold injuries represented over one-third of the cases seen for treatment, and approximately one-third of these received diagnoses of trench or immersion foot.

Frostbite. Frostbite results from the formation of miniscule crystals of ice within the extracellular fluid of the skin and adjacent tissues and is caused by exposure to temperatures below the freezing point. The severity and extent of injury are functions of the temperature and the duration of exposure. Figure 20-2 indicates that human flesh freezes at cooling values of 1,300 to 1,500 calories per square meter per hour. With a wind velocity of 22 miles per hour, exposure at temperatures of 17.6°F (-8°C) for one hour, or -22°F (-30°C) for one minute, will cause human flesh to freeze. This graphic demonstration emphasizes the importance of windchill as a causative agent in frostbite.

Pathogenesis. The multiple and complex mechanisms eventually resulting in tissue damage are not fully understood. Some of the mechanisms which have been implied are:

1. Direct cold effect on certain cellular enzyme systems.
2. Intracellular hyperosmolarity secondary to cellular dehydration as the water from within the cell is drawn into the extracellular fluid to replace the water in the extracellular space which has crystallized into ice.
3. Mechanical disruption of the cellular membrane and intracellular structures by ice crystals, particularly during slow thawing during which some refreezing of the melt occurs. The new ice crystals are actually larger than those formed during the original freezing.
4. Tissue hypoxia as a result of decreased perfusion due to irreversible damage to capillaries and small vessels.

Diagnosis. The development of frostbite is particularly insidious, and the victim is unaware of its happening. Frostbite most commonly occurs on the face, hands, and feet. Its onset is signaled

by a sudden blanching of the skin of the nose, ear, or cheek. This may be subjectively noted by the experienced victim as a momentary tingling or "ping." Subjectively, the patient feels that his face muscles will not work. Telltale, yellow-white spots appear early, and their early observation by another person may minimize tissue damage. A frozen extremity appears white, yellow-white, or mottled blue-white and is hard, cold, and insensitive to touch. Even a very shallow or superficial frostbite injury may have the appearance of being frozen completely solid because of the dermal freezing alone. An elegant classification of cold injury by degree of severity is presented in NAVMED P-5052-29, but such designations are somewhat academic in the clinical situation since the definitive classification into degree of injury is often a retrospective diagnosis and the treatment is the same.

Once thawing has transpired, the injured extremity usually becomes edematous. Large, serum-filled blisters develop within an hour to several days after thawing is complete. Unless accidentally ruptured, the blebs remain intact until the fourth to tenth day postinjury when resorption of the fluid begins. At this time, spontaneous rupture of the blebs may occur. As the blebs dry, a hard eschar begins to separate spontaneously, and the delicate healthy tissue beneath becomes visible.

Should the extent of the tissue damage be so severe as to preclude tissue healing, blebs do not develop, and the skin remains cyanotic and cold. This is most commonly seen in distal phalanges, and evidence of beginning mummification may be observed, often within a few days. Mummification becomes more pronounced over a period of days, weeks, or months, and the demarcation between healthy and dead tissue becomes more obvious. The viable tissues separate and retract from the mummified until spontaneous amputation of the soft tissue is essentially complete.

The foregoing description is based on a clinical pattern uncomplicated by infection or premature surgical intervention. Infection or unwarranted early debridement may result in excessive tissue loss, osteomyelitis with need for successively higher amputations, extensive skin grafting, and prolonged hospitalization.

Treatment. Treatment of frostbite is directed towards the preservation of the maximum amount of viable tissue and the restoration of maximum function. These goals are achieved by rigid adherence to the following principles: gentleness in handling the frozen parts to prevent additional mechanical trauma, rapid thawing of the frostbitten tissue, prevention of infection, early institution of active motion of the injured part, and avoidance of premature surgical intervention. Mills (1973, 1976) has reported good anatomical and functional results by using such a regimen of treatment.

Thermal Stresses and Injuries

When the patient is at a distance from a medical facility capable of providing definitive care, the management of a frostbitten extremity is dependent on the amount of time necessary to reach that facility. If the time is only several hours, it is best that the frozen part be kept in the frozen state until arrival. The patient should be transported with the extremity carefully padded or splinted to avoid mechanical trauma, and the affected part should be either isolated from the heater of the transport vehicle or even placed on ice. Because there appears to be a direct relationship between the amount of time that tissue is frozen and the amount of residual tissue damage, the frozen extremity of a patient who is more than several hours away from definitive care should be thawed by rapid rewarming in an environment where refreezing cannot possibly occur. Then, the thawed extremity must be protected from pressure or mechanical injury. Thawing of a frostbitten part should not be undertaken when there is any danger of refreezing; the danger of thawing and subsequent refreezing is greater than the danger of remaining frozen.

Upon arrival of the patient, the flight surgeon should perform a thorough physical examination to rule out general hypothermia, concomitant injuries, and cardiorespiratory problems. Should general hypothermia be present, or should there be generalized or local tissue anoxia secondary to blood loss or trauma, he must be prepared to perform intubation, cardiac defibrillation, or other resuscitative procedures which may be indicated. Once the examination and any emergency procedures have been completed, the affected part should be rapidly thawed. A whirlpool bath at 100°F to 108°F (38°C to 42°C) is the method of choice. This temperature range is warm enough to dissolve the ice in the tissue rapidly, but not so warm that tissue damage might result from excessive heat. The part should be gently handled to prevent mechanical trauma. Although the thawing process is relatively quick, it is usually quite painful, and morphine or meperidine may be required for relief of pain.

As tissue thawing proceeds, a superficial pink flushing will be seen to progress distally along the extremity. Immersion in the whirlpool bath should be continued until the distal tip of the thawed part flushes, is warm to the touch, and remains flushed when removed from the bath. Occasionally, the flush may not be pink, but rather burgundy or purple, colors which are usually indicative of ischemia and retention of venous blood. In frostbite, however, the color change seems to be directly related to the bath water temperature. The color change is usually transient, but persistent cyanosis or ischemia, despite rapid thawing, may indicate increasing pressure within the fascial compartment due to an associated fracture, sprain, soft tissue injury, or disease, and a fasciotomy may be necessary.

With rapid thawing, the change is dramatic and the patient quickly becomes responsive and even alert. So rapid, however, is this method of thawing, that the rapid entry into the circulation of liberated acid end products of metabolism may precipitate metabolic acidosis and subsequent

death as a result of ventricular fibrillation within one to three hours. Consequently, initial care must also be directed toward the avoidance of acidosis, Electrolytes, pH, PCO₂, and PO₂ should be serially monitored as fluids and sodium bicarbonate are administered. Electrocardiographic monitoring should be simultaneously performed.

Sensation often returns to the affected part with rapid thawing, but this is a transitory phenomenon. The sensation disappears once the blebs develop and separate the epidermis from the dermis or the dermis from the underlying tissue. Sensation does not return again until healing is complete.

Once thawing is complete, the injury is treated in an "open" fashion, and a modified isolation technique is employed. If the lower limbs were frozen, the patient is placed on absolute bed rest, and the legs are elevated and kept on sterile sheets. A protective cradle covered with sterile drapes is placed over the legs to prevent injury or pressure, and sterile cotton pledgets are put between the toes. When the injury is to the hands and forearms, they may be comfortably positioned on sterile sheets placed on the patient's chest and abdomen. Attendants should wear clean gowns and masks, and when changing linens or manipulating the injured part, they should wear sterile gloves. Extreme care should be exercised to prevent further injury during nursing procedures requiring manipulation of the affected part.

The primary goals during this phase of therapy are to maintain joint motion and prevent infection. At the core of the treatment regimen is use of the whirlpool bath at least twice daily. The water temperature is maintained at 95°F to 98.6°F (35°C to 37°C), and hexachlorophene is added to the water for its bacteriostatic effect. The agitated water of the whirlpool bath cleanses gently and promotes physiological debridement while aiding circulation. This treatment is extremely effective in minimizing infection, and as a result, antibiotics are seldom necessary unless there is a very deep infection. A tetanus toxoid booster is routinely administered.

Active exercises are the other indispensable part of this phase of treatment, and they are begun as soon as possible. Hourly digital movements are demanded of the patient. Most patients find the movement easier to perform while in the whirlpool bath due to the softening of the hard eschar by the warm water. When there is lower extremity involvement, Buerger's exercises are performed for 20 to 30 minutes at least four times daily as follows:

1. Patient supine, legs elevated at 30° angle for two minutes.
2. Patient sits on edge of bed, feet dangling:

Thermal Stresses and Injuries

- a. Flexes and extends ankle
 - b. Rotates lower leg
 - c. Spreads and closes toes
- } Slowly and deliberately
for three minutes.
3. Patient lies flat in bed with legs under blanket for five minutes.
 4. Repeat above cycle three to six times per session.

The importance of active physiotherapy during the first six weeks for the prevention of flexion contractures and joint ankylosis cannot be overemphasized.

Because of the prolonged nature of treatment and the danger of addiction, narcotics are used for control of pain only during the initial thawing process. After rapid rewarming, the patient should be switched to aspirin, propoxyphene, or diazepam for the long recovery period. Use of tobacco is prohibited because of the vasoconstrictive effect. Alcohol is generally not permitted because of its variable effect on peripheral blood flow.

The blebs which appear shortly after the initial rewarming process should be left intact. The fluid contained in the blebs is usually sterile, as is the underlying tissue. The blebs generally rupture on about the third to seventh day, and as they dry, hard, dark, and often circumferential eschars develop which may inhibit motion of the digits, particularly the interphalangeal and metacarpal phalangeal joints. Should this occur, the eschars should be carefully split along the dorsum or lateral borders to avoid injury of the underlying neurovascular bundles. The eschar should not be removed. The whirlpool bath will perform that function at a physiological rate and minimize scarring which could occur from cutting into granulating membranes during surgical debridement.

Generally by the 10th to 14th day, and almost always by the 21st day, the eschar has begun to sluff into the whirlpool bath and healing is readily apparent. At that point, isolation techniques and sterile precautions may be terminated. However, the physiotherapy and whirlpool should be continued.

Despite adherence to the foregoing treatment regimen, some digits or distal portions of an extremity may remain black and cold and appear nonviable. Surgical intervention should be withheld until spontaneous amputation of the soft tissue is nearly complete. This may require from three weeks to four months. At that time, the mummified portion may be surgically removed without danger of retraction of distal tissue or a higher amputation than necessary. The rationale underlying this phase of therapy is to permit the injured part every opportunity to

demonstrate its viability. The physician must resist the urge to do something surgical as well as the exhortations of the depressed patient to amputate the injured part prematurely and rid him of the black foot or finger.

The single exception to this policy of nonintervention is when a thawed extremity which was frozen for a relatively long period exhibits a clinical picture similar to anterior tibial compartment syndrome. This includes pain, severe edema, restricted joint motion, evidence of ischemia, and a marked increase in compartment pressures which is obviously compromising the blood supply. In these patients, a fasciotomy or a sympathectomy should be considered. The vascular response is almost immediate following a fasciotomy; and a sympathectomy, according to Mills (1976), appears to promote a much more rapid resolution of any infection which may be present, as well as rapid diminution of edema and a significant lessening of pain. It has also been observed that the combination of the two procedures seems to hasten the demarcation between healthy and non-viable tissue in the affected part.

The whole therapeutic approach for deep freezing injuries is by necessity lengthy, and it requires a great deal of care and patience. During the first several months, a pleasant environment, frequent visits, encouragement, and occupational therapy are mandatory. The patient should be involved in his own treatment by explanations of tissue changes that are taking place and discussions regarding his progress. The patient's observations of joint motility in the whirlpool should be reinforced by the physician in order to substantiate that, despite the grim appearance of the injury, function is being preserved. As in any tissue-destroying illness, a high caloric, high protein diet with vitamin supplements is beneficial.

Other modalities of therapy have been proposed from time to time, and still others are under investigation. The beneficial effects ascribed to steroids and antihistamines in the treatment of cold injury have not been clinically demonstrated. The use of vasodilators has been disappointing. In studies of microcirculation of experimental animals following freezing and thawing, Mundth (1964) reported that immediately following thawing the circulation was apparently unimpaired, but within a few minutes, evidence of obstruction could be seen in the venules. The obstruction apparently began with aggregations of platelets, followed by piling up of erythrocytes behind them with stasis extending back through the capillary bed to the arterioles. Within two hours or less, the stasis had become irreversible, and the vessels were totally filled with a structureless, hyaline-like material. There was tissue edema and evidence of extravasation of hemoglobin into the perivascular spaces. Mundth investigated the use of low molecular weight Dextran in rabbits following freezing and thawing. Examination of the microcirculation demonstrated that the low molecular weight Dextran had alleviated the post-thawing obstruction and was effective in reducing tissue loss in frozen rabbit feet if it was infused as late as two hours following thawing. Clinical experience with this method of treatment is still limited.

Hyperthermia

When heat production or exchange of heat from the environment to the body exceeds heat loss, a state of hyperthermia may develop. Circumstances in which the potential exists for the development of hyperthermia conditions are ubiquitous. Some examples are personnel inspections during hot and humid weather, recruit training, Marine field maneuvers in tropical or subtropical climates, strenuous physical activity by individuals with sunburn, duties in ships' engineering spaces, the "greenhouse" effect in poorly ventilated and unairconditioned aircraft, and extravehicular activity (EVA) by astronauts. In his roles as industrial medical officer and general medical officer, the flight surgeon is frequently involved not only in the treatment of such cases, but also in the assessment of environmental risks, evaluation of equipment, and training of personnel.

Physiology of Hyperthermia

In a discussion of the interaction of environmental physical parameters and physiological processes, it is customary to adopt the engineering usage of the terms "stress" and "strain," particularly since the body's final physiological state reflects both the independent and integrated results of all those factors which exert an influence on heat exchange and the body's regulatory mechanisms. The term "stress" denotes the force or load acting upon the biological system, and the term "strain" is used to designate any resulting distortion of the biological system. Conventionally, stress factors are heat, cold, humidity, radiation, air movement, and surface temperature. Thermal strain, as a response to the imposed thermal stress, may manifest itself in specific cardiovascular, thermoregulatory, respiratory, renal, endocrine, and other reactions which differ in type or degree from accepted norms. A thermal stress is categorized as acceptable when man is able to compensate without undue strain, but it is considered unacceptable when man is able to compensate but incurs severe strain, or when he is unable to compensate and incurs excessive strain. Thermal strains are categorized as those interfering with work performance and safety, and those with overt manifestations of physiological decompensation, such as heat rash, heat cramps, heat exhaustion, heat stroke, or cold injuries.

Table 20-2 contains frequently encountered symbols used to designate environmental and physiological variables in heat exchange and their definitions. The interaction between man and a heat stress environment can be represented by the empirical Heat Balance Equation:

$$M \pm R \pm C - E = S$$

where

- M = metabolic rate of heat production of man
- R = radiative heat gain to or loss from man
- C = convective and conductive heat gain to or loss from man
- E = evaporative cooling
- S = heat storage in man.

Radiation, conduction, convection, and vaporization of water as methods of heat exchange have been discussed in an earlier section of this chapter. In a state of thermal equilibrium, the equation may be rewritten as:

$$M \pm R \pm C - E = 0 .$$

Table 20-2

Symbols and Definitions for Physical Factors in the Thermal Environment and Physiological Factors in Heat Exchange

Physical Factors		Physiological Factors	
Symbol	Meaning	Symbol	Meaning
T_a	Air temperature using dry bulb thermometer.	\bar{T}_s	Mean skin temperature.
\bar{T}_r	Mean temperature of surrounding surfaces (wall temperature). In presence of radiant heat, $T_r > T_a$.	T_c	"Core" or central temperature (measured in the rectum, esophagus, or near the tympanic membrane).
V	Air velocity (fpm or m/s).	$P_{s,w}$	Water vapor pressure of wetted skin at skin temperature.
T_g	Temperature of the 6" black globe. T_g exceeds T_a when $T_r > T_a$. Elevation of T_g in equilibrium with radiant heat varies inversely with convective cooling by V. With appropriate coefficients T_g represents $R + C$.	A	Total surface area of the body (m^2).
$P_{a,w}$	Water vapor pressure of ambient air.	s	Area of wetted surface.
T_{wb}	Temperature of the wet bulb thermometer. Evaporative cooling under forced convection depresses reading of T_{wb} below T_a , the degree varying inversely with $P_{a,w}$. In air fully saturated with water vapor (100% RH) $T_{wb} = T_a$.	$\frac{s \times 100}{A} = \%$	% of wetted body surface.
T_{ie}	Effective Temperature Scale. An empirical index combining T_a (or T_g), T_{wb} , and V into a single value based on sensory effect.*	M	Metabolic rate of body heat production (kcal/hr).
$^{\circ}C_{11}$	Effective Temperature in degrees Centigrade.	met	Unit of M per m^2/hr . Resting M = 1 met or 50 kcal/ m^2/hr
		VO ₂ max	Maximum oxygen uptake. Also called maximum aerobic work capacity.
		SR	Sweat rate (kg/hr).
		E	Body heat loss by evaporation (kcal/hr).
		BF	Blood flow to the skin ($l/m^2/min$).
		C	Conductance = $\frac{M/A}{T_s - T_a}$ [kcal/ m^2/hr per degree of gradient]

* ET Scales in the form of nomograms (Basic Scale for men stripped to the waist and Normal Scale for men lightly clothed) were derived from tests on men moving between two climate chambers, a test chamber with T_a , T_{wb} , and V fixed in various combinations, and a reference chamber with still air fully saturated held at temperatures ranging in different tests from 0 to 43°C. All combinations of T_a , T_{wb} , and V producing immediate thermal sensations which are equivalent to those experienced in the reference chamber were assigned the same Effective Temperature, namely that of saturated still air at that temperature.

(Minard, 1973).

Thermal Stresses and Injuries

Heat transfer by radiation (R) and by convection and conduction (C) between man and his environment may result in a positive or negative heat balance. For example, if the environment is cooler than the man, a negative (toward the environment) heat balance will result. Conversely, when the environment is warmer than the subject, a positive heat balance (toward the subject) results. If uncompensated, this latter state' results in excessive heat storage and leads to the various clinical hyperthermic conditions. Table 20-3 illustrates how the Heat Balance Equation applies to three different circumstances of temperature and vapor pressure gradients between skin and environment. It should be noted that when $\bar{T}_g < T_g$ and P_{wa} approaches or equals P_{ws} equilibrium is not possible either at rest or during work.

Table 20-3

Heat Balance Under Different External Temperature Gradients and Factors
Limiting Endurance Time for Work

External Gradient	Example	Heat Balance	Endurance Time Limited by:	Representative Environments
$\bar{T}_g > T_g$ $P_{wa} > P_{ws}$	$T_g = 25^\circ\text{C}$	$M = R + C + E$	Work Rate	Temperate climate. Also thermally neutral work places.
$\bar{T}_g = T_g$ $P_{wa} > P_{ws}$	$T_g = 35^\circ\text{C}$	$M = E$	Work rate and elevated P_{wa} and/or low V (Restricted evaporation)	Tropical climate. Also canning, textiles, laundries, deep metal mines.
$\bar{T}_g < T_g$ $P_{wa} > P_{ws}$	$T_g = 45^\circ\text{C}$	$M + R + C = E$	Work rate and maximum capacity to sweat (Free evaporation)	Hot desert climate. Also manufacturing of primary metals, glass, chemicals, etc.

(Minard, 1973)

Thermoregulation. Although the thermoregulatory mechanisms in man have not been fully explicated, animal experiments have provided convincing evidence that the temperature regulating center in man lies in the hypothalamus. The anterior portion appears to contain the "heat loss" center which responds to increases in its own temperature as well as to afferent nerve impulses from receptors in the skin. The center mediates heat loss through increased blood flow to the skin and sweating (man) or panting (other mammals). Minard (1973), in his excellent discussion of the physiology of heat stress, proposes a model for the thermoregulatory system controlling body temperature under conditions of heat stress. He structures the model as an analog of an engineering system known as a negative feedback proportional controller. Feedback is negative because the error signal is the difference between the input, the set point of the thermostat (37.0°C for the hypothalamus and 34.0°C for the skin), and the output, T_c and/or T_s . It is a proportional con-

troller because the central drive and effector responses (BF_s and SR) are proportional to the error signal. In the absence of a heat load, central drive is zero, output and input being equal. The model predicts that when equilibrium is reached under a given heat load, core temperature and mean skin temperature (output of the system) will stabilize at a level above the set point by an amount also proportional to the load. The deviation from the set point is called the "load error," and the effectiveness of the controller in temperature regulation depends on its sensitivity to the error signal, or gain. The gain factor is high in individuals with high heat tolerance, and it increases in acclimatization.

Sweat Rate. In response to the stimulus of a heat load resulting in an error signal, skin sweat glands are activated. The number of glands recruited and the rate of secretion of each gland determine the total sweat rate. The estimated 2.5 million eccrine glands can secrete sweat at peak rates of more than 3 kg/hr. for up to an hour in highly acclimatized men, and they can maintain rates of 1 to 1.5 kg/hr. for several hours. When there are no restrictions to evaporation of sweat from the skin (i.e., $SR = E$), and under steady state conditions of work and heat exposure, evaporative cooling is regulated to balance the heat load ($M + R + C$) up to the maximum rate of sweating of 1 kg/hr. Under steady state conditions of work, T_c is constant despite ambient temperatures widely varying from cool to moderately hot, and any elevation of T_c above 37°C depends solely on M , the metabolic work rate. Under constant ambient conditions, however, SR varies with M , to which the elevation of T_c is proportional. Thus, the central drive for sweating is determined by work rate, M , but the actual sweat output is modulated by skin temperature to meet evaporative requirements under conditions from cool to hot, up to the limits of the sweating mechanism.

Sweat Evaporation. As stated previously, the heat of vaporization of sweat is 0.58 kilocalories. The efficiency of body cooling by sweat is a function of the rate of evaporation. The rate is determined by the gradient between vapor pressure of wetted skin, P_{ws} and ambient air, P_{wa} multiplied by a root function of air velocity at the skin surface, $V^{0.6}$, and s , the fraction of body surface, A that is wetted. When evaporation of sweat is restricted by a reduced vapor pressure gradient due to high ambient humidity, more sweat glands are recruited in order to increase the area of wetted body surface. If the evaporative cooling is sufficient to balance the heat load under these conditions, core temperature remains essentially unchanged. As P_{wa} increases or V decreases, s approaches A , and when s equals A , the body surface is 100 percent wetted. Any further increase in sweat production does not contribute to cooling, and the sweat drips off the body and is wasted. Any further restriction on E results in body heat being stored with increased values for both \bar{T}_s and \bar{T}_c . The thermal center responds with an increased central drive for sweating. But, as \bar{T}_s rises, P_{wa} and the evaporation rate increase also, so that a new steady state may be established but at a cost of increased thermoregulatory strain, as reflected in further evaluation of SR, BF_s , and HR (circulatory strain).

Thermal Stresses and Injuries

Therefore, sweat rate under conditions of free evaporation varies linearly with heat load and is proportional to $M + R + C$. Under conditions of restricted evaporation, however, when s/A approaches one, SR is greater than E and is proportional to the increase in T_c and \bar{T}_s . The sweat rate tends to decline with time of heat exposure, particularly under restricted evaporation and when the skin is extensively wetted, but the decline does not interfere with heat loss as long as $SR > E$. The decline might be regarded as an adaptive mechanism to conserve body water and electrolytes under conditions in which more sweat is produced than is useful.

Cardiovascular System. Under comfortable ambient conditions, \bar{T}_s is normally 33°C to 34°C , but under heat stress, it may approach to within a degree or two of T_c , or it may decline to as much as 10°C to 15°C below T_c in the cold. Changes in core to surface gradient are accompanied by alterations in the rate of blood flowing from the core to the surface to meet changing needs in heat conductance. Heat conductance is defined as units of heat transferred to the environment through the skin per unit time per degree of temperature gradient. Under conditions of heat stress, \bar{T}_s rises and the core to skin gradient narrows. Consequently, a greater volume of blood must flow through the skin each minute to achieve the same rate of heat exchange as in a neutral environment. This is the basic cause for heat strain on the cardiovascular system. Conductance, which is a useful index of the strain, is expressed by the following equation:

$$C = \frac{M/A}{T_c - \bar{T}_s} \text{ (kcal/m}^2\text{/hr per degree of gradient).}$$

The narrower the gradient for a given M , or the higher the M for a given gradient, the greater is the BF_s required to transfer metabolic heat from the core to the environment.

In a thermally neutral environment, \bar{T}_s is lower during work than at rest because of redistribution of blood from the skin blood vessels to those of active muscles. The return of adequate venous blood to the heart is maintained by the reduced capacity and increased resistance of skin and visceral vessels together with the pumping action of the muscles. This facilitates increased cardiac output which is proportional to the percentage of maximum oxygen uptake (percent $\dot{V}O_2$) required by skeletal muscle work. When there are external heat loads concurrent with the performed work, however, both the central drive for increased conductance and the rise in local skin temperature cause dilation of skin vessels, thereby increasing their blood capacity and reducing their resistance. BF_s increases but at the cost of reducing venous return to the heart, resulting in a smaller stroke volume. In order to meet the oxygen demand of the working muscles, cardiac output can be maintained only by further constriction of splanchnic vessels and an increase in heart rate. Thus, the thermoregulatory need for increased BF_s , as estimated by C , increases from a

quarter of a liter per minute at rest in a neutral environment to over two liters per minute in men working at three to four *met* (unit of M per M²/hr) under heat stress.

Core Temperature. Figure 20-8 schematically presents selected thermoregulatory responses to heat stress. In Zone A (Full Compensation), SR and BF_s increase proportionally with the total heat load (M + R + C). T_c is maintained at a uniform level which is determined only by M and which is independent of ambient temperatures at lower levels of external heat stress. This is termed the "prescriptive zone" to indicate the range of thermal environments in which men can work without strain on homeostatic core temperature. The upper limit of the prescriptive zone in highly acclimatized men working at 300 kcal/hr. is 31 to 32°CET. The upper limits of this zone are lower at high work rates because T_c is higher.

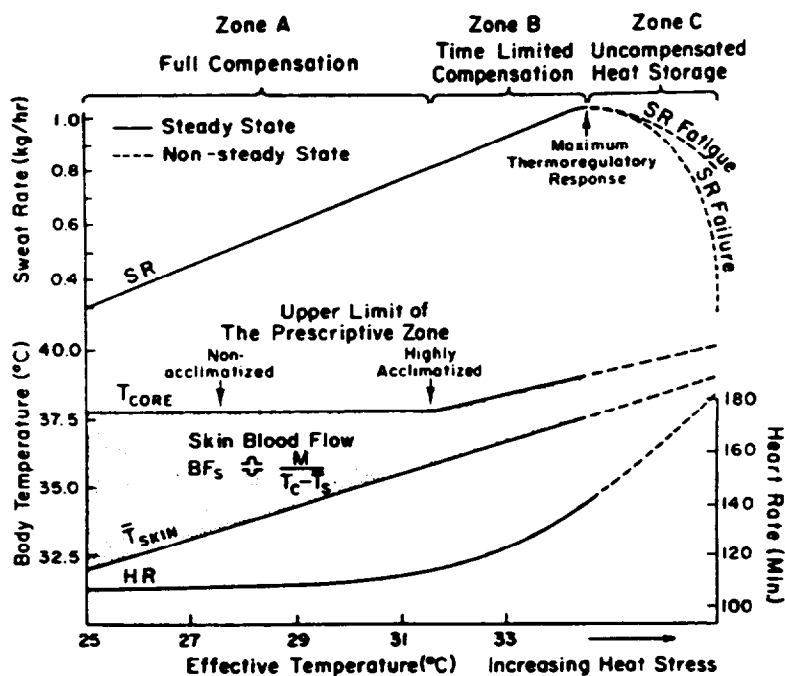

Figure 20-8. Thermoregulatory responses to heat stress in Zone A (Full/Compensation), B (Time Limited Compensation), and C (Uncompensated Heat Storage). Graph illustrates the effector responses (SR, BF_s), circulatory strain (HR), and the controlled variables (T_c, T_s) in a highly acclimatized man working at one-third VO₂ max (M = 300 kcal/hr.) at levels of heat stress up to his limits of tolerance. Responses under steady state conditions are linear with Effective Temperature in Zones A and B. In Zone C, the steady state is impossible. Dashed lines indicate continuous heat storage and show trends only of T_c, T_s, SR, and HR with increasing heat stress (Minard, 1973).

Thermal Stresses and Injuries

T_c in a man performing steady work at 300 kcal/hr is higher in Zone B (Time Limited Compensation) than in the prescriptive zone, up to a T_c limiting value of 39°C (102.2°F). This represents the highest core temperature at which a highly acclimatized man can maintain a steady state of thermal balance, and then for only two hours or less. The upward slope of T_c in Zone B indicates an attempt to maintain the core to surface gradient as \bar{T}_s reaches higher levels, although there is a thermoregulatory strain imposed on T_c .

The maximum tolerable level of heat stress corresponding to the T_c limit of 39 °C (102.2 °F) has been determined to be 34°C_{ET} to 35°C_{ET}. Men who are less fit or less well-acclimatized for work at 300 kcal/hr would reach limiting levels for thermal balance at lower core temperatures and at corresponding lower levels of external heat stress. As a practical guide, the average core temperature of men should not exceed 38°C (100.4°F) for a work shift.

The border between Zones B and C marks the upper limit of man's capacity to sweat. Thus, in Zone C, rate of heat loss fails to match rate of heat gain, and heat storage ensues with T_c and T_s rising continuously in proportion to the heat load. Rate of storage may be accelerated by fatigue or failure of the sweating mechanism. It is not possible to achieve a steady state during continued work, and this is indicated by broken lines in Zone C (Uncompensated Heat Storage). Under extreme heat (e.g., 40°C_{ET} to 45°C_{ET}, the core to surface gradient will be reversed, and the blood returning from the skin will heat the core rather than cool it. Metabolic processes are accelerated by the rising core temperature, further increasing the rate of body temperature rise. Without cessation of work and removal from the environment, continued exposure in Zone C inevitably leads to collapse from circulatory failure or heat stroke.

Under intense radiant heat loads, skin temperature rises rapidly to the pain threshold (45°C, 113°F), and it is the pain which becomes the limiting factor in tolerance time rather than heat storage in deeper tissues.

Heat Tolerance

Acclimatization. Any well-motivated young man in good physical condition who works for the first time under conditions of heat stress will exhibit signs of heat strain evidenced by increased heart rate, high body temperature, and other signs of heat intolerance. But on each succeeding day of heat exposure, his ability to work improves and signs of strain and discomfort diminish. In other words, he adapts to the thermal stress, and as a result of his working in a hot environment, he has acquired the enhanced tolerance to environmental heat stress called heat acclimatization.

The acclimatization process begins with the first exposure to heat and is achieved most safely and expeditiously over a period of one to two weeks by progressive degrees of heat exposure and

physical exertion. In order to achieve maximum acclimatization, the work level should be in the 200 to 300 kcal/hr range. Sedentary work levels will not result in adaptation. A factor apparently essential in inducing acclimatization is the sustained elevation of T_c and T_s above levels for the same work in a cool environment. Acclimatization ordinarily cannot occur when heat stress levels exceed a certain level, and personnel working in areas of unusual stress, such as firerooms and enginerooms, should not be expected to adapt physiologically to their environment if the parameters outlines in Table 20-4 are exceeded.

Table 20-4

Bureau of Medicine and Surgery Recommended Heat Stress Design Conditions for Firerooms of Surface Vessels*

Parameters	Lower Work Level Inside Space	Upper Work Level Inside Space
Dry-Bulb Temperature (°F)	97	105
Wet-Bulb Temperature (°F)	83	84
Globe Temperature (°F)	117	125
Effective Air Velocity At Man (fpm)	250	250
Relative Humidity (%)	56	42
Ambient Vapor Pressure (mm Hg)	25.3	24.6
Wet-Bulb Globe Temperature Index (°F)	91.2	94.3
Mean Radiant Temperature (°F)	155.4	162.0

*All of the above figures apply to normal work sites with a time-weighted-mean metabolic rate of 76 kcal/(m²·hr) for the upper work level and 96 kcal/m²·hr) for the lower work level; data were based upon no cumulative fatigue in personnel (NAVMED P-5010-3, 1974).

Once acclimatization has occurred, there is a significant increase in sweat output which is produced at a lower T_s in comparison to both sweat rates and skin temperatures earlier in the adaptive process. Within the environmental restrictions discussed above, the increase in evaporative cooling with a steeper core to skin gradient is sufficient to compensate fully for the heat load. This is demonstrated by restoration of the core temperature to levels observed while performing the same work in a cool environment. Although BF_s remains elevated following acclimatization, the circulatory load is diminished as evidenced by a reduction in heart rate.

Thermal Stresses and Injuries

Acclimatization to wet heat increases tolerance to dry heat and vice versa. The reason why tolerance to wet heat is increased is not clear, nor are the underlying changes in the thermoregulatory axis which control the adaptive process itself. It is well known that men who work at hot industrial tasks acquire levels of acclimatization commensurate with their average heat exposure, but increased work demands or increased environmental stress may overload their thermoregulatory capacity and lead to signs of overstrain. Heat acclimatization requires periodic reinforcement, such as occurs daily during the work week. A partial loss of acclimatization may be demonstrated after return to work following the weekend, and should the absence be longer, such as a vacation of several weeks, the loss of acclimatization may be substantial.

A summary of physiological indices of advanced heat acclimatization is provided in Table 20-5.

Table 20-5

Physiological Indices of Advanced Heat Acclimatization

Physiologic Parameter	Progressive Adaptive Response
1. <i>Cardiac Output</i> (estimate by noninvasive indirect technique)	1. Increased on day one; decreasing toward normal with progressive exposure.
2. <i>Cardiovascular Reserve</i> (measured in terms of peripheral resistance with peripheral vascular collapse theoretic endpoint)	2. Gradually increasing from first day of exposure.
3. <i>Body Temperatures</i> (rectal, deep esophageal, tympanic, skin)	3. Markedly increased on day one; gradual normalizing thereafter. After adaptation to tropical environmental temperatures a thermal equilibrium was achieved within 30 minutes in acclimatized subjects doing constant moderate work.
4. <i>Sweat Rate</i>	4. Low on day one, increasing daily thereafter until day 8-10, after which time it again decreased toward normal.
5. <i>Urine Osmolality</i>	5. Slight increase on day one with more rapid increments thereafter until day 8-10. Osmolality then decreases each day toward normal (response is similar to that of sweat rate).
6. <i>Serum Osmolality</i>	6. Studies are thus far incomplete, but suggest that changes are minimal during acclimatization. Investigation suggests that other adaptations tend to maintain the osmolar integrity of the serum.

(NAVMED P-5010-3, 1974).

Physical Fitness. A state of good physical fitness alone does not confer heat acclimatization, but physical training even without heat exposure does improve heat tolerance, as indicated by somewhat lower heart rates and core temperatures in men exposed to heat after conditioning as compared with before conditioning. However, sweat rates do not increase and skin temperature remains high. Therefore, it may be said that physical conditioning enhances heat tolerance by increasing the functional capacity of the cardiovascular system. This results from an increase in the number of capillary blood vessels in muscle, thus providing a larger interface between circulating blood and muscle for exchange of oxygen and metabolic waste products. Small veins in tissues other than muscle also develop increased tone and are able to reduce their capacity during exercise, thus promoting an increase in pressure in the large central veins returning blood to the heart. Together, these factors allow an increased maximum oxygen uptake in the physically conditioned individual, permitting him to withstand a greater circulatory strain of work under heat stress.

Surface Area to Weight Ratio. Heat loss is a function of body surface area, A, and heat production is a function of body weight, Wt. Therefore, a low A/Wt ratio is a handicap for individuals performing sustained work under conditions of thermal stress. In obese individuals, as well as those with compact or stocky builds, the A/Wt ratio is relatively low. If lacking in acclimatization, physically unfit and obese men are at greater risk of succumbing to heat stroke.

Age and Disease. A healthy worker over 45 years of age may perform well on hot jobs when he is allowed to work at his own pace. However, under demands for sustained work output in the heat, he is at a physiological disadvantage compared to the younger worker. Between ages 30 and 65, the maximum oxygen uptake declines 20 to 30 percent, and the older worker has less cardiovascular reserve capacity. In addition, at levels of heat stress above the prescription zone, the older worker compensates less effectively for the heat loads, as demonstrated by his higher core temperature and peripheral blood flow for the same work output. This has been attributed to a delay in the onset of sweating as well as to a lower rate of sweating; contributing to greater heat storage and a longer recovery time. The presence of any degenerative diseases of the heart and blood vessels intensifies the age effect by limiting the circulatory capacity to transport heat from the core to the surface.

Illness other than degenerative disease may predispose to the development of heat injury under mild environmental conditions which would ordinarily not be considered to represent a significant risk. Bartley (1977) lists the following heat factors which have been reported in the literature as significant risks for development of heat stroke: acute febrile illness, fatigue, recent immunizations with subsequent reactions, acute and convalescent infections, medications, past history of heat injury, chronic disease such as diabetes or cardiovascular disease, following certain surgical procedures, and lesions of the hypothalamus, brainstem, and cervical part of the spinal cord.

Thermal Stresses and Injuries

Water and Salt Balance. Successful adaptation to heat and the maintenance of effective work performance are dependent on the replenishment of the body water and salt lost in sweat. Sweat volume may amount to 12 liters in a 24-hour period (Dasler, 1971), leading to a contracted extracellular fluid space. A fully acclimatized worker weighing 70 kg can secrete six to eight kilograms of sweat per eight-hour shift. Failure to replace water lost in sweat, despite continued sweating, may result in severe dehydration due to loss of intracellular as well as extracellular fluid. Although water deficits of one kilogram (1.4 percent of body weight of a standard man) can be tolerated without serious effect, deficits of 1.5 kg or more during work in the heat deplete circulating blood volume. Even an acclimatized man will exhibit signs and symptoms of increasing heat strain (elevated T_c and HR, thirst, and severe heat discomfort) resembling those seen in an unacclimatized individual. With water deficits of two to four kilograms (three to six percent of body weight), work performance is impaired, and continued work will lead to signs of incipient heat exhaustion.

A factor in the development of acclimatization is the successful attempt by the body to conserve salt. Already hypotonic sweat is produced in increased quantities with an even lower salt content, and the rate of renal sodium (Na^+) reabsorption is increased. Among the mechanisms proposed to explain the ability to retain Na^+ is an increased plasma renin activity concomitant with the incremented aldosterone secretion which occurs during acclimatization. Studies (Francesconi, Maher, Bynum, & Mason, 1977) using small numbers of experimental subjects suggest that heat acclimatization may reduce the increase in plasma potassium (K^+) induced by mild exercise at high ambient temperatures. No significant differences were observed in urinary potassium excreted by exercising and sedentary subjects. No significant differences in plasma Na^+ levels were demonstrated between exercising and sedentary men, but there was a significant reduction in urinary Na^+ excretion in the exercising men.

The estimated average diet of the general population of the United States contains about 15 gms/day of sodium chloride, including salt shaker supplementation at the table. This would meet the needs of an acclimatized worker producing six to eight kilograms of sweat containing one to two grams of salt during a single shift. During the period of acclimatization, a worker with no previous heat exposure might require supplemental salt because, although maximal sweat rates in unacclimatized workers are lower (four to six kilograms per sweat), salt concentrations are higher (three to five grams per kilogram of sweat) than after acclimatization.. Despite the difficulty of trying to equate time spent in physical conditioning, drills, or field exercises with shifts, a similar magnitude of loss may be experienced by military personnel. A salt deficit of 15 to 25 grams may occur during the first several days of increased thermal stress. If field rations are consumed as meals, supplemental salt is not required because each ration, including the accompanying salt packet, contains 31 grams of salt, and daily dietary intake of salt may reach 93 grams.

An individual's greatest need for salt would occur during the simultaneous stresses of initial physical conditioning and heat acclimatization in a hot, humid environment without water restriction. Although salt tablets, which are 10 grains (0.648 grams) each (0.255 gms of sodium and 0.393 gms of chloride), are available, both experimental and clinical data suggest that unrestricted use of supplementary sodium chloride or salt tablets is contraindicated under most conditions of heat stress. Costill, Cote, Miller, Miller, and Wynder (1975) found minimal physiological benefit in supplementing drinking water with electrolytes when sufficient quantities of those ions were available in the daily diet, and subjects were permitted to ingest food and drink ad libitum. A physiological plasma sodium chloride level can be achieved by providing adequate water, a normal diet, and a salt shaker on the table for conservative use, with no more than the equivalent of two grams of supplementary salt (preferably not as salt tablets) per day.

Progressive dehydration may occur if water is replaced without concurrent replacement of salt because homeostatic controls are designed to maintain a balance between the electrolyte concentrations of the extracellular and intracellular fluid compartments. Deficient salt intake with continued intake of water tends to cause hypo-osmolality of the plasma which suppresses pituitary antidiuretic hormone (ADH). The renal tubules then fail to absorb water, and dilute urine containing little salt is excreted. Thus, electrolyte concentration of the body fluids is homeostatically maintained but at the cost of depleting body water and ensuing dehydration. Under continued heat stress, symptoms of heat exhaustion develop similar to those resulting from water restriction but with more severe signs of circulatory insufficiency and notably little thirst.

BUMEDINST 6260.2 series provides current statements on salt and water requirements.

Alcohol. Many authors have reported an excessive intake of alcohol by patients within hours or a day or two prior to the onset of heat stroke. Striking reductions in workers' heat tolerance on the day following alcoholic excesses have been described. Suppression of ADH by alcohol has been described, and the loss of body water in the urine and resultant dehydration have been postulated to be a primary mechanism.

Hyperthermic Illness

The classification of hyperthermic illness used in this chapter is the one agreed upon jointly by committees representing the United Kingdom and United States in 1964. A summary of the etiology, signs and symptoms, treatment, and prevention of heat illness is presented in Table 20-6.

Table 20-6

Classification, Medical Aspects, and Prevention of Heat Illness

Category	Clinical Features	Predisposing Factors	Underlying Physiological Disturbance	Treatment	Prevention
1. Temperature Regulation					
<i>Heat Stroke and Heat Hyperpyrexia</i>	Heat Stroke: 1) <i>Hot dry skin</i> : red, mottled or cyanotic. 2) <i>High and rising T_e</i> , 40.5°C and over. 3) <i>Brain disorders</i> : mental confusion, loss of consciousness, convulsions, coma as T _e continues to rise. Fatal if treatment delayed. Heat Hyperpyrexia: milder form. T _e lower, less severe brain disorders, some sweating.	1) Sustained exertion in heat by unacclimatized workers. 2) Lack of physical fitness and obesity. 3) Recent alcohol intake. 4) Dehydration. 5) Individual susceptibility. 6) Chronic cardiovascular disease in the elderly.	<i>Heat Stroke</i> : Failure of the central drive for sweating (cause unknown) leading to loss of evaporative cooling and an uncontrolled accelerating rise in T _e . <i>Heat Hyperpyrexia</i> : Partial rather than complete failure of sweating.	<i>Heat Stroke</i> : Immediate and rapid cooling by immersion in chilled water with massage or by wrapping in wet sheet with vigorous fanning with cool dry air. Avoid overcooling. Treat shock if present. <i>Heat Hyperpyrexia</i> : Less drastic cooling required if sweating still present and T _e < 40.5.	Medical screening of workers. Selection based on health and physical fitness. Acclimatization for 8-14 days by graded work and heat exposure. Monitoring workers during sustained work in severe heat.
2. Circulatory Hypostasis					
<i>Heat Syncope</i>	Fainting while standing erect and immobile in heat.	Lack of acclimatization.	Pooling of blood in dilated vessels of skin and lower parts of body.	Remove to cooler area. Recovery prompt and complete.	Acclimatization. Intermittent activity to assist venous return to heart.
3. Salt and/or Water Depletion					
a) <i>Heat Exhaustion</i>	1) Fatigue, nausea, headache, giddiness. 2) Skin clammy and moist. Complexion pale, muddy or hectic flush. 3) May faint on standing with rapid thready pulse and low blood pressure. 4) Oral temperature normal or low but rectal temperature usually elevated (37.5-38.5°C). <i>Water restriction type</i> : Urine volume small, highly concentrated. <i>Salt restriction type</i> : Urine less concentrated, chlorides less than 3 g/l.	1) Sustained exertion in heat. 2) Lack of acclimatization. 3) Failure to replace water and/or salt lost in sweat.	1) Dehydration from deficiency of water and/or salt intake. 2) Depletion of circulating blood volume. 3) Circulatory strain from competing demands for blood flow to skin and to active muscles.	Remove to cooler environment. Administer salted fluids by mouth or give I-V infusions of normal saline (.9%) if unconscious or vomiting. Keep at rest until urine volume and salt content indicate that salt and water balances have been restored.	Acclimatize workers using a breaking-in schedule for 1 or 2 weeks. Supplement dietary salt only during acclimatization. Ample drinking water to be available at all times and to be taken frequently during work day.
b) <i>Heat Cramps</i>	Painful spasms of muscles used during work (arms, legs, or abdominal). Onset during or after work hours.	1) Heavy sweating during hot work. 2) Drinking large volumes of water without replacing salt loss.	Loss of body salt in sweat. Water intake dilutes electrolytes. Water enters muscles, causing spasm.	Salted liquids by mouth, or more prompt relief by I-V infusion.	Adequate salt intake with meals. In unacclimatized men, provide salted (0.1%) drinking water.
4. Skin Eruptions					
a) <i>Heat Rash (miliaria rubra; "prickly heat")</i>	Profuse tiny raised red vesicles (blister-like) on affected areas. Pricking sensations during heat exposure.	Unrelieved exposure to humid heat with skin continuously wet with unevaporated sweat.	Plugging of sweat gland ducts with retention of sweat and inflammatory reaction.	Mild drying lotions. Skin cleanliness to prevent infection.	Cooled sleeping quarters for 1 or 2 weeks. Supplement dietary salt only during acclimatization. Ample drinking water to be available at all times and to be taken frequently during work day.
b) <i>Anhidrotic Heat Exhaustion (miliaria profunda)</i>	Extensive areas of skin which do not sweat on heat exposure, but present goose flesh appearance, which subsides with cool environments. Associated with incapacitation in heat.	Weeks or months of constant exposure to climatic heat with previous history of extensive heat rash and sunburn. Rarely seen except in troops in wartime.	Skin trauma (heat rash; sunburn) causes sweat retention deep in skin. Reduced evaporative cooling causes heat intolerance.	No effective treatment available for anhidrotic areas of skin. Recovery of sweating occurs gradually on return to cooler climate.	Treat heat rash and avoid further skin trauma by sunburn. Periodic relief from sustained heat.
5. Behavioral Disorders					
a) <i>Heat Fatigue — Transient</i>	Impaired performance of skilled sensorimotor, mental, or vigilance tasks, in heat.	Performance decrement greater in unacclimatized, and unskilled men.	Discomfort and physiological strain.	Not indicated unless accompanied by other heat illness.	Acclimatization and training for work in the heat.
b) <i>Heat Fatigue — Chronic</i>	Reduced performance capacity. Lowering of self-imposed standards of social behavior (e.g., alcoholic overindulgence). Inability to concentrate, etc.	Workers at risk come from homes in temperate climates, for long residence in tropical latitudes.	Psychosocial stresses probably as important as heat stress. May involve hormonal imbalance but no positive evidence.	Medical treatment for serious cases. Speedy relief of symptoms on returning home.	Orientation on life abroad (customs, climate, living conditions, etc.)

(Leithead & Lind, 1964, published by permission of F.A. Davis Co.)

Heat Stroke. Heat stroke is a bona fide medical emergency, and if treatment is not instituted immediately, the mortality rate is high. It occurs when the thermoregulatory mechanisms fail for reasons as yet undetermined. The central drive for sweating becomes inoperative, and cooling by evaporation is lost. There is an uncontrolled accelerating rise in T_c due to uncompensated heat storage. Predisposing factors include any of those which adversely affect tolerance to heat. Prodromal symptoms are headache, malaise, discomfort perceived as excessive warmth, or even those symptoms associated with heat exhaustion. The onset is usually abrupt with sudden loss of consciousness, convulsions, or delirium. Typically, sweating is absent, and the patient himself may have noted this prior to the onset of his other symptoms. Since the patient may continue to ingest water in the absence of sweating, overhydration rather than dehydration may occur. Should diuresis occur as a result of this, it should be interpreted as an additional sign of the critical condition of the patient. During the early stages of heat stroke, the patient may experience a febrile euphoria once sweating has ceased and T_c has risen. Physical signs are a flushed, hot, dry skin; in severe cases, there may be petechiae present secondary to direct thermal injury or vascular endothelium which initiates platelet aggregation. T_c is high, frequently in excess of 105°F (40.5°C). A rectal temperature of 108°F (42°C) is not uncommon. As T_c continues to rise, loss of consciousness, convulsions, and coma may ensue. The patient's pulse is full and rapid, while the systolic blood pressure may be normal or elevated, and the diastolic pressure may readily become depressed. Respirations are rapid and deep and simulate Kussmaul breathing. As the patient's condition worsens, peripheral vascular collapse may occur manifested by a rapid pulse, hypotension, and cyanosis. Breathing becomes shallow and irregular. Pulmonary edema and renal failure may develop. If the patient survives until the second day, recovery often occurs, but relapses may occur in the first few days after the temperature has been reduced from the critical level.

Treatment is directed toward rapid restoration of normal temperature. Immediate attempts should be made to lower body temperature to safe levels, T_c of 100°F to 101°F (37.5°C to 38°C). The longer hyperpyrexia continues, the greater is the threat to life. In the field, the patient's clothes should be removed, and if there is a source of cool water nearby, he should be immersed in it. Otherwise, water should be sprinkled over the patient and its evaporation hastened by fanning. In addition to these cooling measures, attendants should rub the victim's extremities and trunk briskly to increase circulation to the skin. The patient should be transported as soon as possible to a facility properly equipped to perform definitive treatment. During transportation, cooling efforts should be continued by permitting passage of air currents through the open door of the field ambulance or helicopter. Once the patient reaches the hospital, he should be placed immediately into a tub of water and ice. His extremities should be continuously massaged as noted above. During immersion, his rectal temperature should be closely monitored, and when it drops to between 100°F and 101°F, the patient may be removed to a hospital bed. Rectal

Thermal Stresses and Injuries

temperature should continue to be monitored every ten minutes until stable. During the first several days, the patient is susceptible to hypothermia as well as relapses of hyperpyrexia. It is therefore desirable to maintain rectal temperature between 100°F and 101°F. Rapidly increasing temperatures can usually be managed with ice water sponge baths and fanning; precipitous drops in temperature may require judicious use of warm blankets. Shivering is associated with increased involuntary muscular activity which is undesirable because it accentuates tissue hypoxia and lactic acid acidosis. If simple warming measures fail to control shivering, the physician may administer small intravenous doses of diazepam (10 mg.)

Hypotensive shock usually responds to the cautious administration of balanced intravenous fluids, but plasma volume expanders may be useful if the patient is normothermic. Vasopressors are to be avoided. Central venous pressure, serum electrolytes, and hourly urinary output must be carefully monitored to avoid hyperhydration. Replacement fluids should be sufficient to repair imbalance of serum electrolytes and to restore acid-base balance, but care must be exercised to detect early signs of pulmonary congestion, rising venous pressure, or renal failure. Administration of oxygen by face mask or nasal catheter may be useful to combat tissue anoxia. Convulsions may be controlled by intravenous use of diazepam or short-acting barbiturates (sodium pentothal). Long-acting barbiturates and narcotics are contraindicated.

Serious physiological damage and altered response to heat stress may persist long after recovery from heat stroke. There is evidence to suggest that heat stroke victims may be more susceptible to recurrent episodes of heat illness under less intense environmental conditions. Therefore, they should never be returned to heat stress similar to that which precipitated their illness without an evaluation and appearance before an appropriate Medical Board. A "Heat Casualty Report" (NAVMED 6500/1) should be submitted to Chief, Bureau of Medicine and Surgery, Department of the Navy, Washington, DC 20372.

Heat Hyperpyrexia. Heat hyperpyrexia is a milder form of the same illness in which there is partial, rather than complete, failure of the central drive for sweating. In heat hyperpyrexia, the core temperature is lower, less than 105°F (40.5°C), and some degree of sweating is present. Central nervous symptoms and signs are less severe. Treatment is directed towards lowering core temperature as in heat stroke, but due to the less severe nature of the illness, less drastic measures may be adequate.

Circulatory Hypostasis. Heat syncope is the clinical manifestation of circulatory hypostasis and is an entity familiar to military medical personnel. It is most commonly seen in personnel standing in parade formation in hot outdoor climates. It is unrelated to salt or water deficiency or to excessive physical activity. Lack of acclimatization may be a predisposing factor together with the

enforced immobility of standing in parade formation. The syncope results from a pooling of blood in dilated vessels of skin and lower parts of the body. Vagotonia may be a contributing factor. The momentary cerebral ischemia is relieved promptly once the patient's posture becomes horizontal as a result of the faint, and recovery is complete once the patient is moved to a cooler area.

Salt and Water Depletion. Disorders of salt and water depletion include the clinical entities of heat exhaustion and heat cramps. These conditions are most commonly seen in unacclimatized personnel who have sweated profusely while performing heavy exertion under conditions of thermal stress. The sweating mechanism remains functional under adequate central drive, but the patients have mismanaged the replacement of water and salt lost in sweating.

1. *Heat Exhaustion.* Patients with heat exhaustion suffer peripheral vascular collapse as a result of dehydration and depletion of circulating blood volume. The depletion of the circulatory blood volume may be absolute and secondary to failure to replace water and salt lost in sweat, or relative due to circulatory strain from competing demands for blood flow to skin and large skeletal muscles. The condition is characterized by profuse sweating, headache, tingling sensation in the extremities, dyspnea, giddiness, palpitations, and gastrointestinal symptoms of anorexia, nausea, or even vomiting. The patient may complain of neuromuscular disturbances with trembling, weakness, and incoordination. He may also experience cerebral signs ranging from slight clouding of the sensorium to actual loss of consciousness. Physical examination reveals a patient in mild to severe circulatory collapse with a pale, moist, even clammy skin and a rapid (120 to 200 beats per minute at rest), thready pulse. Systolic blood pressure may be normal at the time of examination, but prior to the onset of the illness and while at work, it may have been quite elevated (180 mm, Hg or higher) and then may have fallen precipitously while work continued. The pulse pressure, however, generally remains decreased at the time of examination. Oral temperature may be normal or only slightly elevated, but rectal temperature usually is found to be elevated in the range of 100°F to 102°F (37.5°C to 38.9°C). It may be even higher depending on the type and duration of physical activity prior to the onset of illness. In the water restriction type of illness, urine volume is small and the urine is highly concentrated. In the salt restriction type, urine is much less concentrated with the chloride level being less than three grams per liter.

Patients with heat exhaustion generally respond rapidly once they have been removed to a cool place and have rested. Their water deficit should be restored. If strenuous exertion preceded the onset of illness, and if examination of their urine indicates a salt deficiency, cautious administration of 0.1 percent salt solution, orally, or physiological saline, intravenously, may accelerate recovery. Patients should remain at rest until urine volume and salt content indicate that salt and water balances have been restored. Immediate return to duty is inadvisable except in the mildest

Thermal Stresses and Injuries

cases. A 24- to 48-hour period of limited duty for personnel recovering from an episode of severe heat exhaustion is recommended.

2. *Heat Cramps.* Heat cramps are painful spasms of muscles used during work (arms, legs, or abdominal) with their onset being observed during exertion or after work hours. They may occur in conjunction with heat exhaustion, or they may occur as an isolated illness and with normal body temperature. The patient has usually sweated heavily during hot work, experienced thirst, and drunk copious quantities of water without replacing salt loss. The patient presents with cool, moist skin, and his temperature is normal or only slightly elevated. His muscular soreness must be differentiated from that occurring in association rhabdomyolysis, which is accompanied by muscle necrosis often resulting in tea-colored urine. Once the diagnosis of heat cramps is confirmed by serum/urine chemistries, treatment consists of medication for pain and restoration of the salt deficit by 0.1 percent salt solution, orally, or physiological saline, intravenously.

Skin Eruptions and Behavioral Disorders. Skin eruptions and behavioral disorders are summarized in Table 20-6.

The flight surgeon is encouraged to refer to NAVMED P-5052-5, "The Etiology, Prevention, Diagnosis, and Treatment of Adverse Effects of Heat" and NAVMED P-5010-3, *Manual of Naval Preventive Medicine*, Chapter 3: "Ventilation and Thermal Stress Ashore and Afloat" for a more detailed discussion of these topics.

Indices of Thermal Stress

In an effort to maintain maximum productivity of personnel while minimizing their likelihood of developing adverse reactions from exposure to thermal stress, attempts have been made throughout the last several decades to integrate the several environmental, physiological, and behavioral variables affecting heat transfer from man to the environment into a simple index. Such attempts have not met with unqualified success. Such an index must take into consideration dry bulb, globe, and wet bulb temperature readings as well as air velocities at both ventilation duct opening and work location. In addition, workers' body temperatures, work loads, heart rates, and pre- and postexposure body weights must be considered. Ideally, the resultant index should assess the individual worker's cardiovascular reserve under different degrees of heat stress.

Chapter 3, "Ventilation and Thermal Stress Ashore and Afloat," in the *Manual of Naval Preventive Medicine* (NAVMED P-5010-3), concisely describes various indices of thermal stress and summarizes their advantages and disadvantages. The Wet Bulb Globe Temperature index

(WBGT) and the Physiological Heat Exposure Limits (PHEL) are the most widely used thermal indices in the Navy.

Wet Bulb Globe Temperature Index

This index was developed in the late 1950's to provide a convenient method to assess, quickly and with minimum operator skills, conditions which imposed intolerable levels of thermal stress on military personnel. Fundamentally, the WBGT Index is an algebraic approximation of the Effective Temperature concept.

The WBGT Index is computed from readings of (1) a stationary wet bulb thermometer exposed to the sun and to the prevailing wind, (2) a black 'globe thermometer similarly exposed, and (3) a dry bulb thermometer shielded from the direct rays of the sun. It is important that the readings be taken in an area representative of the conditions to which the personnel will be exposed. Construction and assembly details for a WBGT Index field apparatus can be found in NAVMED P-5052-5. The temperature of the wet bulb is depressed compared to the dry bulb reading for the air temperature because of evaporation resulting from the natural motion of the ambient air. Therefore, a principal advantage in using the WBGT Index is that wind velocity does not have to be measured. Of the six formulae which have been developed to obtain the WBGT Index, only two are in common use:

$$\text{WBGT Index} = (0.7 \times \text{WB}) + (0.2 \times \text{G}) + (0.1 \times \text{DB})$$

$$\text{WBGT Index} = (0.7 \times \text{WB}) + (0.3 \times \text{G})$$

where

W B = wet-bulb temperature

G = globe temperature

DB = dry-bulb temperature.

The first formula was originally applied to outdoor environments and the second to indoor spaces. It has since been demonstrated that the first formula is reliable in both situations. Incidence of heat casualties has been reduced during Marine Corps recruit training by applying the WBGT Index. Table 20-7 outlines the recommendations for different levels of physical activities at several WBGT ranges. It applies especially to personnel during training and recreational exercises in hot weather. It is not a substitute for the Physiological Heat Exposure Limits (PHEL) curves (discussed below) whose application is more suitable for an industrial type exposure, nor is it necessarily useful in operational settings.

Thermal Stresses and Injuries

Table 20-7

WBGT as a Guide in Regulating Intensity of Physical Exertion During First 12 Training Weeks in Hot Weather*

WBGT Index (°F)	Intensity of Physical Exertion
78–81.9	Extremely intense physical exertion may precipitate heat exhaustion or heat stroke, therefore, caution should be taken.
82–84.9	Discretion required in planning heavy exercise for unseasoned personnel. This is a marginal limit of environmental heat stress.
85–87.9	Strenuous exercise and activity (i.e., close order drill) should be curtailed for new and unseasoned personnel during the first three weeks of heat exposure.
88–89.9	Strenuous exercise curtailed for all personnel with less than 12 weeks training in hot weather.
90 and Above	Physical training and strenuous exercise suspended for all personnel (excludes operational commitment not for training purposes).

*This table must not be used in lieu of the Physiological Heat Exposure Limits (PHEL) (NAVMED P-5010-3, 1974)

The development of a WBGT Meter, which is a compact electronic instrument that independently measures the dry-bulb, wet-bulb, and globe temperatures and air velocity, and translates these variables directly into the WBGT Index, has provided the flight surgeon with a portable means to assess thermal stress in any space aboard ship.

Physiological Heat Exposure Limits (PHEL)

Integration of human metabolic heat production with the WBGT Index has allowed for the refinement and redefinition of heat tolerance limits. These newer indices have been designated PHEL. The PHEL recognize that under conditions of maximum work and heat stress the heat

strain, although readily apparent, will be reversible. These curves represent the results of Navy research on personnel whose ages ranged from 18 to 40 years. The end point designated as an acceptable tolerance limit was a rectal temperature of 102°F (38.9°C) or a rapid rate of temperature change. Time-weighted means were calculated for both metabolic heat production and WBGT exposure in order to allow for the subsequent development of a set of time maximum heat exposure limits. The experimental data from which the PHEL were derived allowed for the development of a related series of rest/work ratios for different degrees of physical activity.

The Physiological Heat Exposure Limits are *maximum* allowable standards, and they should be applied only in cases of short-term work exposures of up to eight-hours duration. The limits presume that no prior heat injury is present and that no cumulative heat fatigue exists prior to reexposure. Whether or not these assumptions are valid has not as yet been demonstrated.

In the application of heat stress standards, sound health, physical conditioning for the specific task, and adequate rest and nutrition are essential in order to minimize the effects of heat stress. Drinking water should be unrestricted and readily available. Threshold WBGT values for the hottest two-hour period of the work shift should be determined based on the workload of personnel. Table 20-8 presents the WBGT threshold values useful in identifying heat stress levels at which sound preventive measures should be instituted. They should not be confused with PHEL which deal with maximum time-weighted-mean limitations on an individual's work capacity in hot environments.

Table 20-8

Recommended Threshold WBGT Values for Instituting Sound Hot Weather Preventive Measures

Work Load	Threshold 2-Hour Exposure WBGT Values (°F)
Light Work (time-weighted-mean metabolic rate of 152 kcal/hr)	86
Moderate Work (time-weighted-mean metabolic rate of 192 kcal/hr)	82
Heavy Work (time-weighted-mean metabolic rate of 232 kcal/hr)	77

(NAVMED P-5010-3, 1974).

Thermal Stresses and Injuries

Figure 20-9 illustrates a PHEL chart for practical use. Work levels corresponding to curves A, B, and C are given in Table 20-9. Table 20-10 combines the data presented in Figure 20-9 and Table 20-9 and describes Physiological Heat Exposure Limits as functions of WBGT Index and metabolic work rate. When conditions of thermal stress preclude the worker's completing an eight-hour shift, the PHEL for that particular WBGT Index is often referred to as "stay time." Adherence to exposure time limits permits adjustment of the work/rest cycle in order to allow the body to dissipate the heat stored during periods of activity. Cool rest areas should be provided to maximize the benefits of the rest period and to avoid cumulative heat fatigue. Environmental engineering can do much to modify the determinants of heat stress, but aboard ship, operational exigencies and economic constraints may mandate the use of the number and duration of exposures as the most practical and expedient measure for the prevention of heat illness.

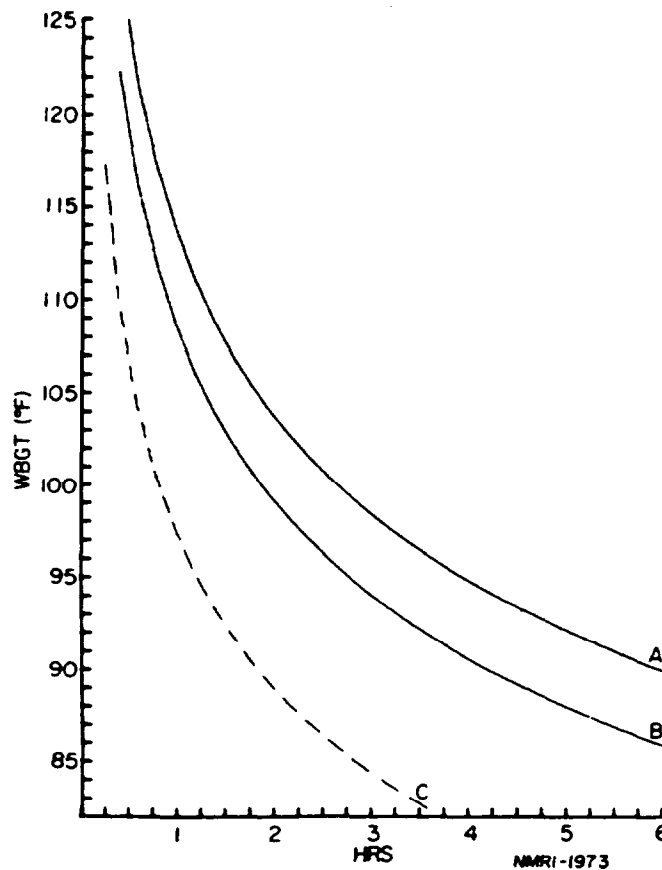

Figure 20-9. Physiological heat exposure limit (PHEL) chart for practical usage (NAVMED P-5010-3, 1974).

Table 20-9

Duties Corresponding to Metabolic Rates of Respective PHEL Curves in Figure 20-9

PHEL Curves (t_{wm} Metabolic Rates)	Duties*
"A" (152 kcal/hr)	<i>Water Level Checkman</i> during other than heavy repair or casualty control activity.
"B" (192 kcal/hr)	<i>Burnerman</i> during other than heavy repair or casualty control functions; <i>Messenger</i> during other than full power conditions or when continuous mobility is not required.
"C" (252 kcal/hr)	<i>Messenger</i> during full power operation or other activities requiring continuous mobility; any personnel involved in heavy repair work requiring manual labor (e.g., pump disassembly); casualty control functions; laundry/scullery work assignments.

*These duties are comparable with those assignments found aboard steam propulsion plant ships rated at 600 and 1200 pounds per square inch.
(NAVMED P-5010-3, 1974).

Table 20-10

Physiological Heat Exposure Limits versus WBGT*

WBGT (°F)	Curve "A" (t_{wm} Metabolic Rate = 152 kcal/hr)		Curve "B" (t_{wm} Metabolic Rate = 192 kcal/hr)		Curve "C" (t_{wm} Metabolic Rate = 252 kcal/hr)	
	Hrs.	Mins.	Hrs.	Mins.	Hrs.	Mins.
84	(Over 8 hrs.)		7	10	3	10
86	(Over 8 hrs.)		6	00	2	40
88	7	10	5	00	2	10
90	6	00	4	10	1	50
92	5	00	3	30	1	30
94	4	20	3	00	1	20
96	3	40	2	30	1	10
98	3	10	2	10	1	00
100	2	40	1	50	0	50
102	2	20	1	40	0	40
104	2	00	1	20	0	40
106	1	40	1	10	0	30
108	1	30	1	00	0	30
110	1	20	0	50	0	20
112	1	10	0	50	0	20
114	1	00	0	40	0	20
116	0	50	0	40	0	20
118	0	50	0	30	0	10
120	0	40	0	30	0	10
122	0	40	0	20	0	10
124	0	30	0	20	0	10

* Assumes no cumulative fatigue or predisposing illness prior to heat stress exposure.
(NAVMED P-5010-3, 1974).

References and Bibliography

- Anderson, G.T. Minutes of the 66th Joint Medical Research Conference. Washington, D.C.: Office of the Director of Defense Research and Engineering, 4 April 1967.
- Anderson, K.L. Thermogenetic mechanisms involved in man's fitness to resist cold exposure. In A. Borg & J.H. Veghte (Eds.), *The physiology of cold weather survival* (AGARD-R-620). London: Technical Editing and Reproduction Ltd., June, 1974, 1-5.
- Bartley, J.D. Heat stroke: Is total prevention possible? *Military Medicine*, 1977, *142*, 528-535.
- Belding, H.S. Control of exposure to heat and cold. In Department of Health, Education, and Welfare, *The industrial environment - its evaluation and control*. Washington, DC: U.S. Government Printing Office, 1973, 563-572.
- Blockley, W.V. Temperature. In Webb, P. (Ed.). *Bioastronautics data book* (NASA SP-3006). Washington, DC: U.S. Government Printing Office, 1964.
- Brown, J.R., & Dunn, G.W. Thermal stress: The need for an international standard. *American Industrial Hygiene Association Journal*, 1977, *38*, 180-183.
- Collis, M.L. Man in cold water. *Navy Lifeline*, January/February 1976.
- Collis, M.L., Steinman, A.M., & Chaney, R.D. Accidental hypothermia; An experimental study of practical rewarming methods. *Aviation, Space, and Environmental Medicine*, 1977, *48*, 625-632.
- Costill, D.L., Cote, R., Miller, E., Miller, T., & Wynder, S. Water and electrolyte replacement during repeated days of work in the heat. *Aviation, Space, and Environmental Medicine*, 1975, *46*, 795-800.
- Dasler, A.R. & Hardenburgh, E. Decreased sweat rate in heat acclimatization. *Federal Proceedings*, 1971, *30*, 209.
- Davis, T.R.A. Non-shivering thermogenesis. *Federation Proceedings*, 1963, *22*, 777-782.
- Department of the Navy, Bureau of Medicine and Surgery. Cold injury (NAVMED P-5025-29). 1976.
- Department of the Navy, Bureau of Medicine and Surgery. Essential information regarding prevention of heat casualties (BUMMEDINST 6200.7A). 1977.
- Department of the Navy, Bureau of Medicine and Surgery. The etiology, prevention, diagnosis, and treatment of adverse effects of heat. (NAVMED P-5052-5). 1957.
- Department of the Navy, Bureau of Medicine and Surgery. *Manual of naval preventive medicine*. Chapter 3: Ventilation and thermal stress ashore and afloat (NAVMED P-5010-3). 1974.
- Department of the Navy, Bureau of Medicine and Surgery. Water and salt requirements in hot environments and climates (BUMMEDINST 6260.2 Series).
- Francesconi, R., Maher, J., Bynum, G., & Mason, J. Recurrent heat exposure: effects on levels of plasma and urinary sodium and potassium in resting and exercising men. *Aviation, Space, and Environmental Medicine*, 1977, *48*, 399-404.
- Golden, F.S.C. Immersion hypothermia. In Borg, A. & Veghte, J.H. (Eds.), *The physiology of cold weather survival* (AGARD-R-620). London: Technical Editing and Reproduction, Ltd., 1974, 77-90.
- Golden, F.S.C. Recognition and treatment of immersion hypothermia. *Proceedings of the Royal Society of Medicine*, 1973, *66*, 1058-1061.
- Golden, F.S.C., & Hervey, G.R. A class experiment on immersion hypothermia. *Journal of Physiology*, 1972, *227*, 35-36.

- Gregory, R.T., & Doolittle, W.H. Accidental hypothermia. Part II. Clinical implications of experimental studies. *Alaska Medicine*, 1973, 15, 48-52.
- Grossheim, R.L. Hypothermia and frostbite treated with peritoneal dialysis. *Alaska Medicine*, 1973, 15, 53-55.
- Hawryluk, O. Why Johnny can't march: Cold injuries and other ills on peacetime maneuvers. *Military Medicine*, 1977, 142, 377-379.
- Hayward, J.S., & Steinman, A.M. Accidental hypothermia: An experimental study of inhalation rewarming. *Aviation, Space, and Environmental Medicine*, 1975, 46, 1236.
- Hertig, B.A. Thermal standards and measurement techniques. In Department of Health, Education, and Welfare, *The industrial environment - its evaluation and control*. Washington, DC: U.S. Government Printing Office, 1973, 413-430.
- Jansky, L. Comparative aspects of cold acclimatization and nonshivering thermogenesis in homeotherms. *International Journal of Biochemistry and Biometrology*, 1969, 13, 199-209.
- Keatinge, W.R. The effects of subcutaneous fat and of previous exposure to cold on the body temperature, peripheral blood flow and metabolic rate of men in cold water. *Journal of Physiology*, 1960, 153, 166-178.
- Kerslake, D.M. The effects of thermal stress on the human body. In Gillies, J.A., (Ed.), *A textbook of aviation physiology*. New York: Pergamon Press, 1965, 409-440.
- Krog, J. Peripheral circulatory adjustment to cold. In Borg, A., & Veghte, J.H. (Eds.), *The physiology of cold water survival* (AGARD-R-620). London: Technical Editing and Reproduction, Ltd., 1974, 7-15.
- Leithead, C-S., & Lind, A.R. *Heat stress and heat disorders*. Philadelphia: F.A. Davis Co., 1964.
- Mills, W.J., Jr. Frostbite, a discussion of the problem and a review of an Alaskan experience. *Alaska Medicine*, 1973, 15, 27-47.
- Mills, W.J., Jr. Out in the cold. *Emergency Medicine. Common Emergencies in Daily Practice*, 1976, 8, 134-147.
- Minard, D. Physiology of heat stress. In Department of Health, Education, and Welfare, *The industrial environment - its evaluation and control*. Washington, DC: U.S. Government Printing Office, 1973, 399-412.
- Molnar, G.W. Survival of hypothermia by men immersed in the ocean. *Journal of the American Medical Association*, 1946, 131, 1046-1050.
- Morgan, C.T., Cook, J.S., III, Chapanis, A., & Lund, M.W. (Eds.). *Human engineering guide to equipment design*. New York: McGraw-Hill, 1963.
- Mundth, E.D. In Viereck, E. (Ed.). *Proceedings, Frostbite Symposium*. Fort Wainwright, Alaska: Arctic Aeromedical Laboratory, 1964.
- O'Donnel, T., Jr. Acute heat stroke. Epidemiologic, biochemical, renal, and coagulation studies. *Journal of the American Medical Association*, 1975, 234, 824-828.
- Sipple, P.A., & Passel C.F. Measurements of dry atmospheric cooling in subfreezing temperatures. *Proceedings of the American Philosophical Society*, 1945, 89, 177-199.
- U.S. Naval Flight Surgeon's Manual*. Prepared by BioTechnology, Inc., under Contract Nonr-4613(00). Chief of Naval Operations and Bureau of Medicine and Surgery. Washington, DC, 1968.
- Webb, P. Temperature stresses. In Armstrong, H.G. (Ed.). *Aerospace Medicine*. Baltimore: The Williams & Wilkins Co., 1961, 342-344.

CHAPTER 21

TOXICOLOGY

Introduction
General Principles
Toxic Substances
Glossary
References

“No substance is a poison by itself. It is
the dose that makes a substance a poison...”
Paracelsus (1493-1541)

Introduction

The aircraft carrier and flight lines are industrial environments and, as such, harbor a variety of chemical agents which may have toxicological properties. Therefore, it is mandatory that the capable naval flight surgeon have a general understanding of toxicology principles and their application, as well as knowledge as to where he or she may find up-to-date information about these chemical agents and the potential harm and effects they may produce. This chapter will outline some broad toxicologic principles, as well as review some of the more common agents with which one may come into contact while practicing aerospace medicine.

Toxicology is defined as the study of the nature and mechanism of toxic effects of substances on living organisms and other biological systems. It also deals with the quantitative assessment of the severity and frequency of these effects in relation to the exposure of the organisms.

The term “xenobiotic” may be defined as a foreign compound that is biologically active and nutritionally valueless. Although there are many naturally occurring xenobiotics, during the latter portion of the twentieth century by far the largest source of these compounds has been synthetic. By definition, these compounds are neither harmful nor helpful, only bio-active, with no nutritional value.

Paracelsus deduced that all substances were not equally toxic and that toxicity depended on the amount of exposure. This led to the idea of the “dose-response” relationship (i.e., a given

amount of exposure resulted in certain effects which could be known, predicted and understood). An arbitrary ranking of toxicity, the inherent capacity of a substance to produce injury, can be made according to dose. This is usually based on an acute dose. Using ranking data, it is possible to estimate the potential hazard (the practical certainty that injury will occur when a substance is used in a prescribed manner) or safety (the practical certainty that no injury will occur when a compound is used in a certain way) of most xenobiotics. Remembering that exposure to xenobiotics may be either accidental or deliberate, we can state that a toxic substance is any stimulus that under certain conditions will evoke an adverse effect on living systems.

General Principles

A brief review of the dose-response relationship and its graphic representation is necessary as background for the ensuing discussion. Within the discipline of toxicology, the dose is plotted along the abscissa and the response (i.e., effect, mortality, etc.) is plotted along the ordinate. Considering the response to follow a Gaussian distribution within the normal population, one achieves the plot as in Figure 21-1a. When one plots the cumulative mortality, the typical sigmoid curve results as in Figure 21-1b. One will notice that between the 16th and 84th percentiles, the sigmoid curve is nearly straight. This portion of the curve represents one standard deviation from the mean and includes 68 percent of the responses. Two standard deviations would include 95 percent of the responses, and three standard deviations would include 99 percent of the responses.

The dose-response relationship is graphically displayed by plotting the frequency of an event vs. the dose on a log scale, which results in a sigmoid-shaped curve. This sigmoid curve can be converted to a straight-line relationship by plotting on a probit basis (Figure 21-1c). The probit format uses the standard deviation where the mean equals zero. In order to produce all positive numbers, five is added to the standard deviation.

Percent response	Standard deviation	Probit value
0.1	-3	2
2.3	-2	3
15.9	-1	4
50.0	0	5
84.1	+1	6
97.7	+2	7
99.9	+3	8

This representation makes the comparison of different toxic agents easier. Although the mean effect is identical, the substance represented by line B is more toxic than substance A, because it causes more effect at lower doses (Figure 21-2).

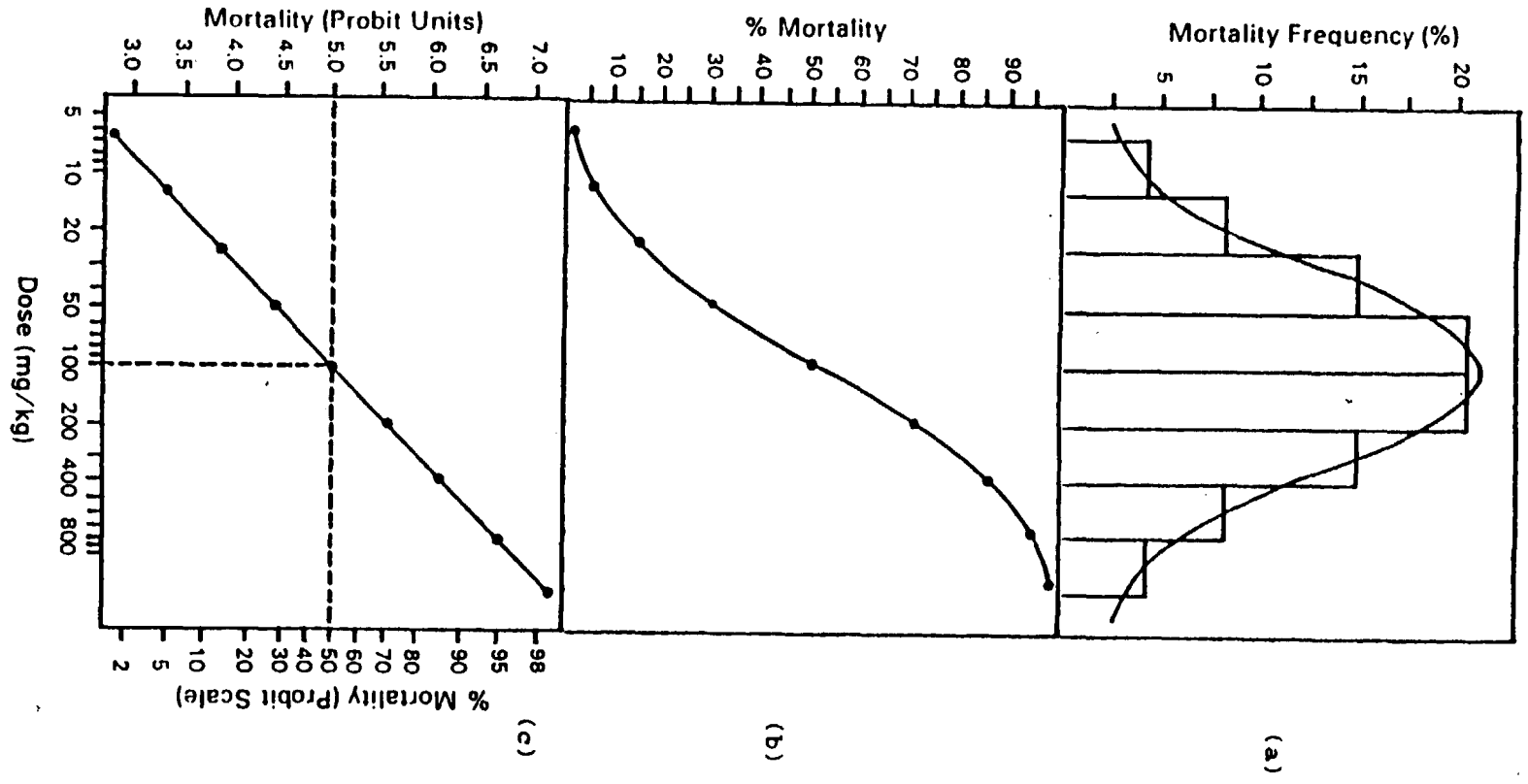

Figure 21-1. Dose-response curves plotted as mortality frequency (a), cumulative mortality (b), and on a probit basis (c). (See text)

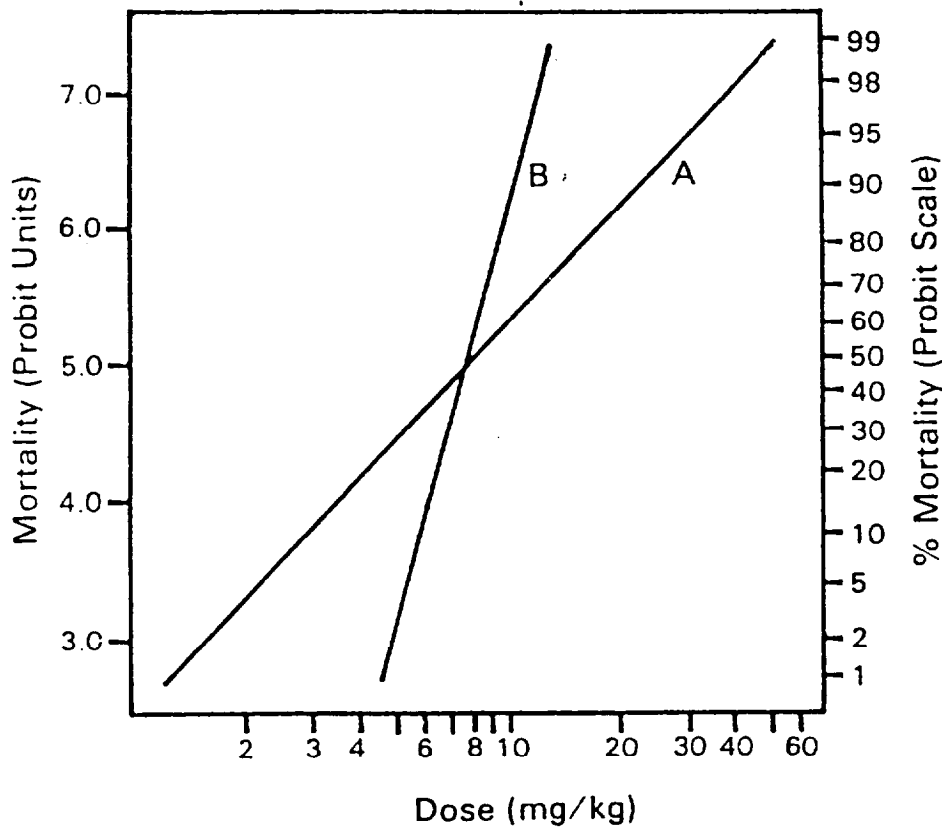

Figure 21-2. Diagram of dose-response relationship for two chemicals, A and B. Because of the steeper slope for chemical B, the 'safe' dose range is narrower.

This is obviously oversimplified. One must also consider the risk of exposure before assessing the hazard. If the risk of exposure to substance A is greater than the risk of exposure to substance B, then the toxicological hazard of substance A is greater than that of substance B. With this background, it is now possible to discuss further general principles of toxicology.

For the ensuing discussion, reference to Figure 21-3 will be beneficial. Absorption of toxic substances may occur through the skin, the GI tract, lungs, or several minor routes. The nature and intensity of the effects on an organism depend on its concentration in the target organs. Concentration depends on the administered dose, absorption, distribution, binding, and excretion.

Transport of a toxic substance across membranes may occur by either passive diffusion or facilitated diffusion, terms with which you should be familiar. Passive diffusion is related to a concentration gradient across a membrane and to the lipid solubility of the substance. Many tox-

icants are ionizable and, therefore, less able to penetrate cell membranes because of their low lipid solubility. Xenobiotic metabolism, to be discussed later, generally results in a substance becoming more readily excretable.

Facilitated diffusion, on the other hand, relies upon a complex being formed between the chemical and a macromolecular carrier. This mechanism has a limited capacity; when the carrier becomes saturated, the reaction assumes zero-order kinetics. Competitive inhibition can occur among chemicals utilizing the same carrier. Whereas active transport requires energy because it occurs against a gradient, facilitated diffusion is not energy dependent.

DISTRIBUTION, EXCRETION, AND ABSORPTION

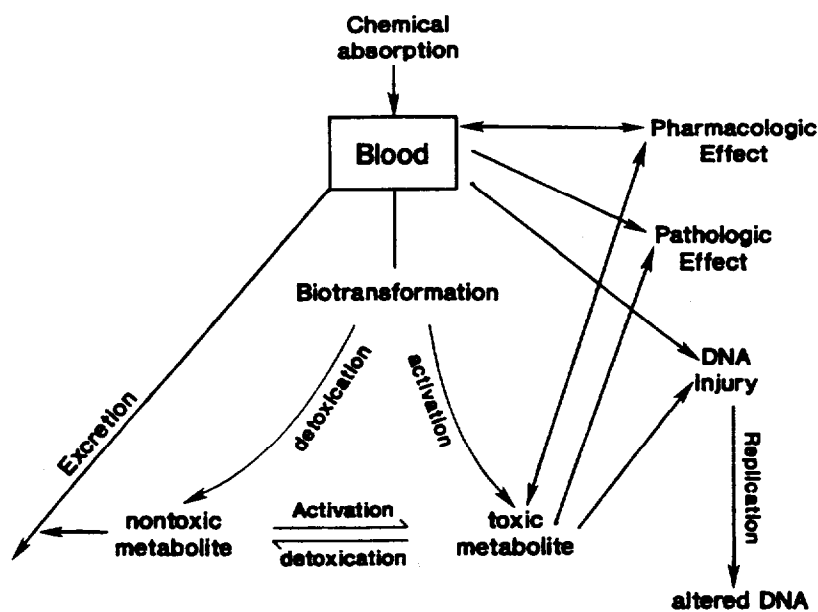

Figure 21-3. Schematic representation of the potential pathways a chemical may follow to produce possible toxicity. See text for a more complete discussion.

Distribution of a substance is dependent upon blood flow, barriers (e.g., blood-brain), binding, and storage. Covalent binding is generally irreversible and leads to significant toxic effects, whereas, monovalent binding is usually reversible. The liver and kidney have high capacities for binding, therefore many toxic effects are manifest in these organs. Adipose tissue acts as a storage depot for lipid-soluble substances.

Toxic substances may be excreted as the parent' chemicals, as metabolites, or as conjugates. Generally, when xenobiotic metabolism results in more polar chemicals, they are more readily excreted by the kidneys.

Biotransformation of Toxicants

Biotransformation of toxicants (Figure 21-4) occurs predominantly in the liver, although some biotransformation occurs in the lungs, stomach, intestine, skin, and kidneys. Phase I biotransformations are oxidation, reduction, and hydrolysis. Phase II biotransformations result in conjugate formation. Metabolites and conjugates are usually more water- soluble and more polar, which makes them more readily excretable. However, in some cases, the metabolite is more toxic (termed bioactivation).

Oxidation reactions involve cytochrome P-450 and NADH cytochrome 450 reductase. These are termed mixed function oxidases (MFO's). Reduction reactions require reductases. Hydrolysis of toxicants involves the formation of ester-type bonds.

Conjugation reactions are of several types, including glucuronide formation, sulfate conjugation, methylation, acetylation, amino acid conjugation, and glutathione conjugation. Glucuronide formation is the most common and important. Sulfate conjugation is catalyzed by sulfatransferases. Methylation is a minor route. Acetylation occasionally results in bioactivation by decreasing the solubility of the substance in water by formation of an amine.

Bioactivation may result in epoxide formation or N- hydroxylation. In the GI tract, nitrites, along with certain amines and the acidic environment, may produce nitrosamines which are potent carcinogens. Bioactivation may also result in free radical formation.

There are a number of factors which may modify the toxic effects of different substances. Toxicity usually depends upon the dose and the duration of exposure. Sex, age, nutritional, and hormonal factors, as well as physical, environmental, and social factors may play a role. Simultaneous and consecutive exposure to more than one chemical may result in additive, synergistic, or potentiated effects. Likewise, chemical antagonism, functional antagonism, competitive antagonism, and noncompetitive antagonism may be factors to consider. Without further detail, suffice it to say that potential toxic substances may undergo a variety of pathways toward producing toxicity, or having their toxic potential decreased.

Toxicology

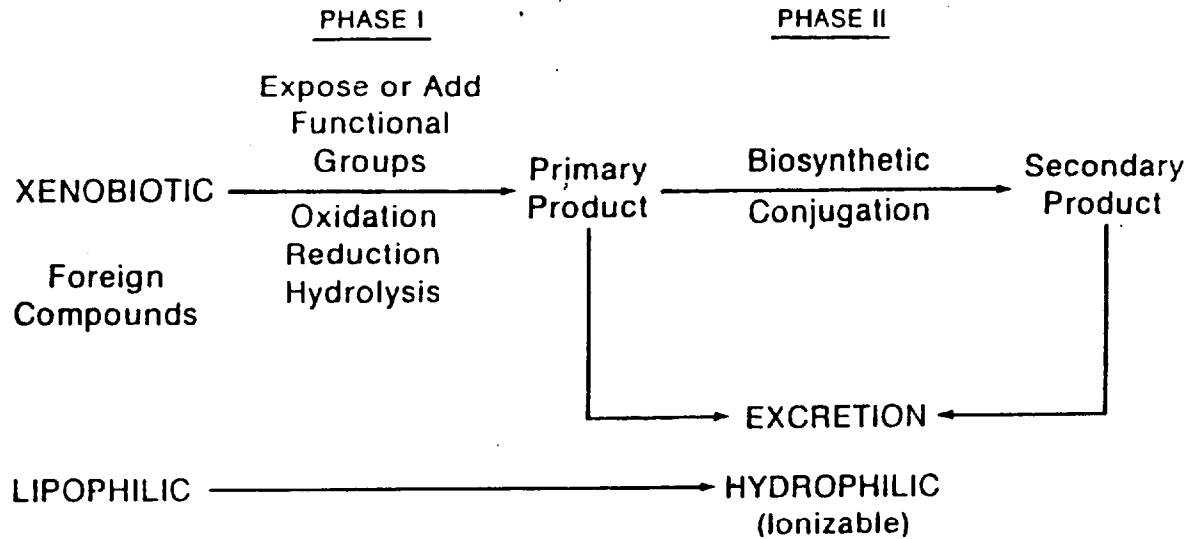

Figure 21-4. Integration of Phase I and Phase II biotransformations. See text for complete discussion.

Toxicological Evaluation

Toxicological evaluation involves several concepts which must be defined. Risk denotes the probability (expected frequency) that a chemical will produce undesirable effects under specified conditions. The NEL (no effect level) is the maximum dose that has not induced any sign of toxicity in the most susceptible species of animals tested and using the most sensitive indicator of toxicity (not applied to carcinogens). There is no threshold defined for carcinogens because cancer cells can be induced by a single change in the cellular genetic material and they are self-replicating.

The LD_{50} is also utilized to classify the toxicity of substances (Table 21-1).

Duration and frequency of exposure are also important parameters. An exposure of less than 24 hours is defined as an acute exposure. Subacute exposure is repeated exposure over one month or less. Subchronic exposure is exposure occurring over one to three months. Chronic exposure is that which occurs over a period greater than three months.

Table 21-1

Toxicity Rating Chart

Toxicity Rating or Class	Dosage	Probable Lethal Oral Dose for Humans
		For Average Adult
1. Practically nontoxic	> 15 g/kg	More than one quart
2. Slightly toxic	5-15 g/kg	Between pint and quart
3. Moderately toxic	0.5-5 g/kg	Between ounce and pint
4. Very toxic	50-500 mg/kg	Between teaspoonful and ounce
5. Extremely toxic	5-50 mg/kg	Between seven drops and teaspoonful
6. Supertoxic	< 5 mg/kg	A taste (less than seven drops)

Potential Effects of Exposure to Toxicants

Exposure to certain toxicants may result in carcinogenesis, mutagenesis, or teratogenesis. Carcinogenesis is declared an outcome when there is observed an increased frequency of tumors, when a tumor is noted in an exposed subject and not in controls, when tumors known to occur are noted to occur at an earlier onset, or there is an increase in the number of tumors identified in individual animals. Genotoxic carcinogens are those which covalently bind with genetic macromolecules. Epigenetic carcinogens produce an increased tumor yield by promoting the replication of cells initiated by genotoxic carcinogens. Direct acting carcinogens are differentiated from precarcinogens. Precarcinogens require bioactivation before exerting their effect. Epigenetic carcinogens are divided into co-carcinogens and promoters. Co-carcinogens enhance activity only when given simultaneously. Promoters exert their effect when given subsequent to the genotoxic carcinogen (Table 21-2).

Mutagenesis entails the concepts of gene mutation chromosomal effects, DNA repair, and recombination. Gene mutation results from addition, deletion, or substitution of base pairs. Direct chromosomal effects include deletion, duplication, or translocation. DNA repair and recombination are self explanatory. Teratogenesis results in the formation of congenital defects.

Table 21-2

Comparison of Biological Properties of
Initiating Agents and Promoting Agents

Initiating Agents	Promoting Agents
1. Carcinogenic by themselves “solitary carcinogens”	1. Not carcinogenic alone
2. Must be given before promoting agent	2. Must be given after initiating agent
3. Single exposure is sufficient	3. Require prolonged exposure
4. Action is “irreversible” and additive	4. Action is reversible (at early stage) and not additive
5. No apparent threshold	5. Probable threshold
6. Yield electrophiles -- bind covalently to cell macromolecule	6. No evidence of covalent binding
7. Mutagenic	7. Not mutagenic

Target organs of toxicants include lungs, liver, kidney, skin, eye, nervous system, reproductive system, heart, and immune systems. Toxicants may exert their effect locally in the lung, or the lung may only serve as the site of absorption. Because of the high metabolic rate of the liver, this is often the site of a toxic chemical's effect. Other reasons for the liver's frequent involvement in toxicological effects include: a large number of toxicants gain their entry via the gastrointestinal tract; there exist a large number of binding sites in the liver; and there is a high concentration of xenobiotic-metabolizing enzymes in the liver. Centrilobular lesions occur due to the increased amount of cytochrome P450 in this region, as well as a lower concentration of glutathione in this region. The nervous system, which on one hand, is protected by the blood-brain and blood- nerve barriers, however, also has an increased susceptibility due to the increased metabolic rate of neurons.

Types of Hazardous Substance Exposure Controls

Hazardous substance exposure controls include: substitution, engineering controls, personal

protective devices, and administrative controls.

Substitution implies using a less hazardous material, however, the substituted material seldom works either as well or as cheaply. Substitution is the best type of control.

Engineering controls involve placing permanent barriers between man and the hazard. It can be simple or it can be very expensive. Exhaust systems designed to deliver sufficient air exchange to the entire working area are an uneconomical utilization of energy because of the high power requirements. The flight surgeon should be aware that these exhaust systems, though highly visible and sometimes equally audible, are a shotgun approach and often fail to accomplish their purpose. Evaluation of the effectiveness of such systems falls into the purview of the industrial hygienist, available as a consultant from the Regional Preventive Medicine Unit. Engineering controls are the next best type of control.

Personal protective devices are self-donned temporary barriers. These offer an efficient form of protection. When inhalation of vapors is the danger, specific guidelines relative to the physical state of the aerosol must be considered. When used correctly, they offer excellent protection for the worker. Three general categories of respiratory protective devices are: (1) mechanical filters, (2) chemical absorptive filters, and (3) atmosphere-supplying respirators. The Navy's Oxygen Breathing Apparatus, which generates a 30-minute supply of oxygen and effectively seals the wearer from the noxious environment, should be familiar to every operational medical officer.

An area of particular concern to the medical officer relates to shipboard "void" entry. A void is a sealed compartment which is available for emergency counter-flooding in a battle situation. Entry to a shipboard void is a most hazardous undertaking. In spite of safeguards, precautions, and regulations to the contrary, unauthorized shipboard void entry has acquired a well-deserved reputation as a killer of sailors and their well-meaning rescuers. The problem is simple asphyxia, because the normal oxidative processes in the sealed compartment deplete the void atmosphere of oxygen.

Personal protective devices often work well, however, a sizable number of workers simply cannot be relied upon to use the devices.

Administrative controls entail setting limits, or educating those who may be exposed. Although important, it is the most difficult of the controls to enforce and should not be relied upon routinely.

Toxic Substances

The major difficulty in the study of toxicology is that there are too many toxicants. The sheer volume of detail is daunting. What is more important is to realize that there are a large variety of potential toxicants. One must consider the possibility of exposure when evaluating a patient's complaints. Here, the history of possible exposure is paramount, then one must have knowledge of where to find appropriate information to acquire the details about a possible toxicant. The *NIOSH/OSHA Pocket Guide to Chemical Hazards* is a good source for exposure limits which are not addressed in the following discussion. Substances that you may encounter while you are practicing aviation medicine are listed below.

Hydrocarbons -- General Notes

Hydrocarbons are divided into two general classes, aliphatic and aromatic. Aromatic compounds contain a benzene ring. Aliphatics are everything else. Saturated compounds are "saturated" with hydrogen and contain no carbon to carbon double or triple bonds. Alkenes have double bonds, alkynes have triple bonds. Solvents are composed predominantly of hydrocarbons, thus their importance in aviation. Solvents are substances capable of dissolving another substance (solute) to form a uniformly dispersed mixture (solution). Solvents are either polar or nonpolar. Hydrocarbon solvents are generally nonpolar. Exposure to solvents occurs primarily through inhalation of vapors or through skin contact.

The very short chain gases; methane (C1), ethane (C2), propane (C3), and butane (C4), are biologically inert and nontoxic. They may serve as simple asphyxiants as they will not support life. They have no significant narcotic effects as straight chain compounds. The rules change with other than the straight chain isomers. Cyclopropane is an excellent anesthetic, but it is explosive. The C5 through C8 straight chain compounds are powerful narcotics. Above C8 are weak narcotics. Above C18 are solids. These are broad generalizations. Gasoline is C5-C15 with a few aromatics. Cyclic and unsaturated compounds tend to be more narcotic.

The most common acute effect of hydrocarbons in the workplace is not a loss of consciousness, but instead, a pre-narcotic syndrome of mild uncoordination and general malaise shading gradually into more severe symptoms. Many organic solvents have the potential upon acute high level vapor exposure to cause narcosis and death. Disorientation, euphoria, giddiness, confusion, progressing to unconsciousness, paralysis, convulsion, and death from respiratory or cardiovascular arrest are typically observed. In the majority of subjects, recovery from CNS effects is rapid and complete following removal from exposure. One must also remember fire and explosion are common hazards associated with use of solvents. Aspiration of any of these organic fuels can cause chemical pneumonitis.

No common organic fuels can be considered pure. All are mixtures defined by certain physical parameters such as specific gravity, boiling point, or viscosity. As a general rule, the more volatile, the more toxic as well as the more hazardous. Usually the compounds are excreted rapidly, but some have long term effects. Chronic exposure to Benzene may cause leukemia. Benzene more commonly causes bone marrow depression. Carbon disulfide may cause psychosis and peripheral neuropathy of sensory nerves. Vinyl chloride may cause hemangiosarcoma of the liver although polyvinyl chloride is harmless. Aromatic nitro and amino compounds cause production of methemoglobin, which interferes with normal oxygen transport.

Solvents are used in dry-cleaning agents, drying compounds, degreasers, and liquid extractions.

Aviation Gasoline (AVGAS)

AVGAS has been better known for its flammability than for its significant toxicity. Exposure may occur during handling, storage, or engine maintenance. In these circumstances, it may be inhaled or absorbed.

AVGAS fumes are an upper respiratory irritant and produce tearing, choking, rhinorrhea, coughing, and excess salivation. If these symptoms are insufficient to prevent further exposure, more dangerous CNS effects may occur. AVGAS may cause CNS hyperactivity, presenting as simple excitement, disorganized hyperactivity, confusion, seizure, or death. The clinical picture may be complicated by CNS depression due to anoxia. Rapid vaporization of AVGAS can cause chemical skin burns, particularly when soaked clothing or even soaked rags in a pocket are left in prolonged proximity to the skin.

JP4 and JP5

JP4 and JP5 are jet engine fuels. JP4 is 65 percent kerosene and 35 percent gasoline, while JP5 is kerosene. Their method of absorption is primarily by inhalation, although superficial cutaneous absorption is also common. Ingestion is rare. In high concentrations, they may cause headache, nausea, confusion, drowsiness, convulsions, coma, and finally death. Skin exposure leads to defatting and dermatitis. Prolonged skin exposure can lead to second degree burns. Ingestion leads to chemical pneumonia.

In summary, hydrocarbon mixtures are frequently found in the Navy with the typical hydrocarbon toxicity.

Ethylene Glycol

Ethylene glycol is a low molecular weight alcohol. It is not an inhalation hazard unless heated. Accidental or purposeful ingestion may occur. In cases of fatal poisonings, symptoms include those of typical alcohol intoxication followed by coma, pulmonary edema, and death within 72 hours. In nonfatal cases, acute tubular necrosis with anuria occurs within 24 hours; 100 cc may be fatal. Liver alcohol dehydrogenase metabolizes ethylene glycol to oxalic acid, which is the likely cause of the metabolic acidosis and subsequent nephrotoxicity.

Ethyl alcohol is a better substrate for alcohol dehydrogenase, which accounts for its use as therapy in massive ingestion. The oral loading dose is 0.6 gm of 50 percent ethanol per kg body weight. Hourly oral maintenance doses of 109 mg of 20 percent ethanol per kg body weight should be administered, along with rapid initiation of hemodialysis.

Ethylene glycol is found in antifreeze, hydraulic fluids, condensers, and heat exchangers.

Triorthocresyl Phosphate - TOCP

TOCP is an aromatic ester with three benzene rings. It is absorbed by ingestion. This was found in small amounts in green hydraulic fluid. This compound occurs as a contaminant in some other products. It is never produced deliberately. The new hydraulic fluids have no TOCP. Approximately one gallon of this hydraulic fluid would have to be ingested before a toxic dose of TOCP would be absorbed. There has never been a documented case of TOCP toxicity in the Navy.

This agent basically causes an ascending paralysis.

Benzene

Benzene is the basic unsaturated resonating ring compound. It is the basis of all aromatic compounds. Benzene is rapidly absorbed via inhalation of vapor and distributed throughout the body, tending to concentrate in tissues with high fat content. Measurement of total urinary phenols gives the most specific indication of exposure.

Acute exposure to high concentrations results in CNS depression with headache, nausea, dizziness, convulsions, coma, and death. Contact with broken skin may result in erythema, blistering, or dry, scaly dermatitis. Benzene is best known for its chronic effects; aplastic anemia, preleukemia, and acute myelocytic and monocytic leukemia.

Benzene is used extensively as a solvent. It may contaminate gasoline, paint remover, degreasers, and kerosene. It was also recently found in illegal cocaine.

Toluene

A benzene ring with an attached methyl creates toluene. Its method of absorption is by inhalation - formally common with glue sniffers. Toluene is an irritant to the eyes, respiratory tract, and skin. It is a CNS toxicant which may produce exhilaration, inebriation, headache, extreme lassitude; and in high concentration, collapse, coma, and death. Abuse (sniffing) produces hyperchloremic acidosis, renal tubular acidosis, weakness, hypokalemia, and hypophosphatemia.

Toluene is a solvent for parts and coatings. It is also a component of motor and aviation fuels.

Carbon Tetrachloride

Carbon tetrachloride is an absolutely superb solvent and degreaser of metal. Carbon tetrachloride is absorbed by inhalation and percutaneously. It proved to be a good fire extinguisher because heat and carbon tetrachloride form compounds which use up available oxygen; however, they form, among other things, phosgene. It has a history of use as a delouser and vermifuge. Previously used as a fire extinguishing agent, it is now outlawed for use. Chronic exposure causes liver damage with destruction of hepatocytes. It is also a potent liver carcinogen. It is not now used due *to* severe immediate plus delayed toxicity.

Trichloroethylene - TCE

Trichloroethylene is quite volatile and is absorbed by inhalation. Trichloroethylene is a CNS depressant with symptoms of headache, dizziness, vertigo, tremors, sleepiness, fatigue, and blurred vision. Intoxication is similar to alcohol. There have been many sudden deaths from ventricular fibrillation from users of this compound. TCE is hepatotoxic and probably a hepatocarcinogen.

Trichloroethylene is the principal solvent in vapor degreasing. This was the "safe" substitute for carbon tetrachloride. It is used as a dry-cleaning solvent and metal degreaser in certain shipboard shops with specific venting. Workers who have been exposed to TCE and consume alcoholic beverages within a few hours usually develop a "degreaser's flush"; red blotches on the skin caused by intense vasodilation of the superficial skin vessels.

In summary, trichloroethylene is a liquid which is almost as good a cleaner as carbon

Toxicology

tetrachloride, has similar qualitative, but much less quantitative effects. It is safer than carbon tetrachloride, but more dangerous than perchloroethylene and methyl chloroform.

Tetrachloroethylene

Tetrachloroethylene is another chlorinated hydrocarbon, also known as perchloroethylene. Its method of absorption is by inhalation and percutaneously. It is a narcotic, a hepatotoxin, and inducer of liver cancer.

Tetrachloroethylene is used only in dry-cleaning plants. Of the three, this is safer than trichloroethylene and much safer than carbon tetrachloride. It is more dangerous than methyl chloroform or freon.

Freon

Freon is a trichloro-trifluoro-ethane with many possible isomers. It is absorbed by inhalation. This is one of the safest and most commonly used solvent propellants, and refrigerant products in the aviation community. When inhaled, it is a mild CNS depressant. It is also a skin defatter. The major toxic effect occurs with deliberate abuse causing simple hypoxia due to displacement of oxygen in the breathing gas.

Methyl Ethyl Ketone - MEK

Methyl ethyl ketone is much like acetone, but less volatile. It is rapidly absorbed through the skin, then rapidly excreted through expired air. Inhalation may cause narcosis. Skin contact causes marked defatting and a dermatitis.

Methyl ethyl ketone is found in solvents or resins, lacquers, paints, oils, pigments, dyes, and polymers. It is very common in shore facilities, but not used on ships.

Methyl Chloroform

Methyl chloroform is a carbon with three chlorines and a methyl group. It is absorbed by inhalation. Methyl chloroform can cause narcosis, but practically this is seldom seen. It causes dizziness, uncoordination, drowsiness, increased reaction time, unconsciousness, and death. Methyl chloroform is used on ships and ashore as a solvent and degreaser. It is often found in electronics repair areas. It is one of the least toxic of the chlorinated solvent chemicals.

Carbon Monoxide

Carbon monoxide (CO) is a product of the incomplete combustion of carbon compounds and is absorbed by inhalation. It is a well-known competitive hemoglobin binder (the affinity of CO for hemoglobin being 210 times greater than O₂), also less well known as a direct cellular toxin at the electron-transport level. Carbon monoxide causes both anemic and histotoxic hypoxia.

It is difficult to correlate laboratory-derived percentages of COHb to clinically-observed effects. For practical purposes, 30 percent COHb is accepted as the level at which functional compromise is recognizable, levels greater than 50 percent correlate well with fatal incapacitation.

COHb level	Symptoms
> 10 percent	headache
20-30 percent	nausea, weakness, occasional vomiting
35-45 percent	clouding of mental alertness, collapse, coma
> 50 percent	death

The relative toxicity of CO increases with altitude. This is partially due to the lower partial pressures existing at high altitude. The biological half-life of CO for an aviator breathing pure air at sea level is one hour. Breathing 100 percent O₂, the aviator can completely clear the COHb in the same amount of time. The treatment of carbon monoxide poisoning is hyperbaric oxygen.

Carbon monoxide is common in internal combustion engine exhaust and in cigarette smoke. Very small amounts exist in jet exhaust. Engine exhausts contain variable amounts of CO depending on the type of engine and the power setting. For a reciprocating engine, the exhaust contains 8.5 percent CO at takeoff power setting and three percent CO at cruise power. Jet exhaust contains less than one percent CO and, therefore, is not of clinical significance.

CO is the classic killer: ubiquitous, silent, deadly; a colorless, odorless, tasteless gas. It associates 210 times more readily with hemoglobin than oxygen. It has a four hour half- life in air, and a forty minute half-life in oxygen at one standard atmosphere and about half that at 60 feet in the hyperbaric chamber. The treatment of choice is hyperbaric oxygen.

Chlorobromo Methane (CBM)

Halogenated hydrocarbons make good fire extinguishers because, in the process of pyrolyzation, the oxygen needed to support combustion is removed from the air as the parent compound

Toxicology

is transformed into a myriad of other chemicals. Pyrolysis resultant compounds are phosgene, HCl, HBr, and CO, with their related syndromes. Phosgene becomes HCl in the lungs and causes severe pulmonary edema. The method of absorption of chlorobromo methane is by inhalation and skin absorption.

Chlorobromo methane is an aircraft engine fire extinguisher for internal combustion engines. When a pilot pulls the T-handle in the cockpit in response to a fire warning light, CBM is sprayed on the fire. In spite of the pyrolysis products produced, CBM is considered safe for the aircrew because of its rapid dissipation and the distance between the crew and the extinguisher system.

OTTO Fuel

OTTO fuel is a nitrated ester: 1,2 propylene glycol dinitrate. This is a torpedo fuel. The method of absorption is by inhalation or percutaneous absorption. This product is extremely volatile and TLV's can readily be exceeded. OTTO fuel has vascular effects, starting with headache, which occur after inhalation. Methemoglobinemia is seen with chronic inhalation exposure. Ingestion can cause circulatory collapse and death. Torpedos are not only submarine items, we also can drop them from aircraft.

Halon

Halon is a generic term meaning halogenated hydrocarbon. Halon 1301 is in use in the Navy. It is a gas. Generally, those compounds containing fluorine tend to be less toxic, whereas those with bromine or iodine are more toxic than those hydrocarbons containing chlorine. The method of absorption is by inhalation. These are CNS depressants. Cardiac arrhythmias may result, and myocardium is sensitized to epinephrine. In new ships, halon is utilized to flood spaces to stop fire. It is harmless, if breathed for only a few minutes.

Hydrazine

Hydrazine, N_2H_4 , is absorbed by inhalation and skin contact. Inhalation leads to pulmonary edema. Skin contact causes severe burns. Hydrazine is a missile fuel, It is also found in the space shuttle and the F-16. Hydrazine is a very toxic and hazardous compound used as a fuel.

Isocyanate

Isocyanate is toluene-2, 4-diisocyanate, also known as TDI. Isocyanate is absorbed by inhalation of paint vapor and mist. Exposure results in an asthma-like syndrome, due to prior sensitiza-

tion. Repeat exposure of even small amounts to a sensitized person can cause symptoms. However, five percent of the population is readily sensitized to this chemical and will present with acute bronchospasm, even in the absence of any prior allergic history. The patient who has demonstrated sensitivity to TDI must be permanently protected from further TDI exposure. Polyurethane paints, the standard aircraft paint, are common in the Navy because they are particularly corrosion-resistant. In summary, isocyanates are the monomers of polyurethane paint. The cured (polimerized) paint is harmless.

Hydraulic Fluid Red (Aircraft)

The red hydraulic fluid which is found in aircraft is petroleum based and inflammable. It does contain traces of TOCP. When burned, it liberates phosgene, which in the lungs becomes HCl. Phosgene is a war gas causing pneumonitis and severe pulmonary edema. Red hydraulic fluid is absorbed by inhalation and via skin contact. Skin contact for prolonged periods can cause dermatitis. Being found in aircraft hydraulic lines, inhalation of the mist is possible when a line breaks under pressure. In summary, red hydraulic fluid is an aircraft hydraulic fluid of mild toxicity except when burned and, therefore, a very minor hazard.

Hydraulic fluid green (Shipboard)

Green hydraulic fluid is found shipboard. This is a green synthetic based fluid that does not burn easily. It is called cellulube, although that is an obsolete brand name. It is absorbed by inhalation, skin contact, or ingestion. Green hydraulic fluid causes a mild dermatitis on contact. Ingestion is sometimes deadly, more because of the hydrocarbon effects than the TOCP. Approximately one gallon of this fluid would have to be consumed in order to receive a toxic dose of TOCP. This fluid is found primarily in deck edge elevators. A large amount of this substance is in the piping of the elevators. TOCP is a contaminant and the new "cellulube" has much less of it. Sometimes the new cellulube is blue in color, which confuses the issue somewhat. In summary, green hydraulic fluid is a fairly non-toxic material found shipboard that has received attention far out of proportion to its importance.

Plastics

The predominate importance of plastics lies in their pyrolysis products. It burns to CO, HCl, HF, HCN, H₂S, and SO₂. The method of absorption is through inhalation. The pyrolysis products create a black, choking, toxic smoke that quickly incapacitates. Much of the interior of passenger aircraft contain plastics. In summary, these are largely cosmetic interior appointments which become deadly in a fire.

Methyl Alcohol

Methyl alcohol, CH_3OH , is absorbed by ingestion. Absorption produces disturbances of vision and metabolic acidosis. High exposure- results in headache, vertigo, unsteady gait, weakness, nausea, vomiting, and inebriation. Indistinct vision, changes in color perception, and blindness are common symptoms. Within the Navy, methyl alcohol is found in deicing fluid. It is also a solvent in paint, stains, varnishes, cements, dyes, and inks.

The treatment for methyl alcohol exposure is ethyl alcohol, because of its greater affinity for ADH (alcohol dehydrogenase).

In summary, drinking methyl alcohol can result in permanent blindness. It is a minor hazard as most people know about the dangers of wood alcohol.

Deicing Fluids

Deicing fluids are composed of methyl, ethyl, and isopropyl alcohols. In the Navy, these are used on aircraft windshields and propellers. When they are absorbed after ingestion, intoxication with methyl effects is produced.

Organophosphates

Organophosphates are discussed here as a group. They are absorbed through intact skin and the eyes. Organophosphates inhibit the enzyme cholinesterase and the toxic effects are related to the resulting increase in endogenous acetylcholine at the synaptic sites. Monitoring enzyme activity not only can serve as a measure of acute toxicity, but also can be used to monitor occupational exposure (remove from exposure if enzyme activity decreases more than 25 percent from pre-exposure levels). The time of onset of symptoms after toxic exposure can be very rapid, but rarely longer than a few hours. If the patient is still alive after 24 hours, survival is likely. Recovery, when it occurs, is usually rapid and complete. Early symptoms are pupillary constriction, chest tightness, and headache. More severe exposure produces coughing, wheezing, and increased bronchial secretions. Weakness and fatigability lead to twitching, fasciculations, and eventual respiratory paralysis. CNS symptoms include anxiety, restlessness and irritability.

The treatment of organophosphate poisoning consists of atropine 1 to 2. mg every 15 to 30 minutes until tachycardia, flushing and dry mouth occur. Atropine does not reverse phosphorylation of cholinesterase, but blocks the effect of acetylcholine. The inhibition of the enzyme will be reversed by 2-PAM (Protopam Chloride) if given early enough before the aging process occurs (given as 1 gm slowly and repeated in one hour pm).

For monitoring workers, both RBC and plasma cholinesterase should be measured. Plasma cholinesterase decreases earlier, and returns more promptly. RBC cholinesterase decreases less readily and has a slower return (however, is more representative of functional cholinesterase). Baseline levels are very important because of variability.

Parathion

Parathion is a complex organophosphate. Absorption is via ingestion or inhalation. Parathion is the insecticidal equivalent of a war nerve gas. It is a cholinesterase inhibitor leading to respiratory arrest. Parathion is deadly and has caused many times the number of deaths caused by DDT. However, it does not persist in the environment and does not bioconcentrate.

DDT

DDT is a halogenated hydrocarbon. By humans, it is generally absorbed by ingestion. Of note, this chemical bioconcentrates. DDT may cause hyperesthesia of the mouth and face early; followed by parasthesias, tremor, confusion, malaise, headaches, fatigue, and delayed vomiting. Convulsions occur only in severe poisoning. DDT is no longer used in the Navy. The EPA cancelled its use for all crops in 1972, and all except emergency cases in 1973. This chemical is primarily of historical interest.

Beryllium

Beryllium is a hard, light, easily machined, useful metal. Absorption occurs via inhalation of the dust. Beryllium produces pulmonary and systemic granulomatous disease requiring exposure over months to years. There is a possible long latent period (suspected cancer inducer). Exertional dyspnea is the most common symptom of chronic disease. Cough, fatigue, weight loss, chest pain, and arthralgia may occur. Beryllium pneumonitis acts like the classic pneumonitis where the X-ray looks worse than the patient. The pneumonia may appear up to six weeks after a beryllium exposure of 1 to 20 days duration and can require up to six months to resolve. Beryllium pulmonary granulomatosis is the most feared form of reaction, appearing weeks to years after the initial exposure and closely resembles sarcoid in that it is not merely pulmonary in focus. There is no correlation between exposure intensity and this reaction. The diagnosis of beryllium pulmonary granulomatosis is made mostly by history and by exclusion, since there is no reliable method for beryllium assay, and the X-ray is nonspecific. Overall mortality from this syndrome has been estimated to be as high as 30 percent and as low as 2 percent. It is difficult to differentiate from other pulmonary disease.

Toxicology

Treatment of berylliosis is cessation of further exposure, and possibly steroids.

Beryllium is found in aircraft brake drums of the S-3 and F- 14. Modern technology has produced new uses of beryllium in nuclear reactors, electronic equipment, guidance and navigation systems, rocket parts, and heat shields.

In summary, used brakes are the dangerous ones. The aircraft brake shop is the focus of the hazard. Good housekeeping is the answer.

Cadmium

Cadmium is an elemental metal. Absorption occurs via inhalation of fumes. Typically, the fumes result from acetylene cutting of metal plated with cadmium. A symptom-free period is followed in 4 to 10 hours with dyspnea, cough, chest tightness, chest pain and burning. Metal fume fever is shaking, chills, and myalgia. This may progress to pulmonary edema 24 to 48 hours after exposure. Chronically, cadmium can cause pulmonary fibrosis, liver and kidney damage, and cancer of the lung and the prostate. This is probably the most harmful fume.

Cadmium in the Navy is found in electroplating, as a stabilizer in plastics, and as a component in nickel-cadmium batteries.

Treatment of cadmium exposure is dimercaprol (BAL), although this may produce renal damage due to the large urinary excretion of cadmium. The same may be true with calcium disodium (EDTA).

In summary, cadmium is a common, useful metal with extremely dangerous fumes. Most toxicity is caused by not knowing the cadmium is present.

Chromium

Chromium is a metal with trivalent and hexavalent ions. Routes of absorption include the inhalation of fumes and percutaneously. Chromium exposure generally results in cough, wheezing, pain on inspiration, fever, weight loss, and possible chemical pneumonitis. This is a trace element required for health. Only the hexavalent form is dangerous and causes both skin ulcers and respiratory ulcers. It may be a carcinogen with a long latent period. In the Navy, chromium is found in chrome plating and as a paint primer (corrosion resistance). It is a common ion found in rework facilities which causes severe ulcers which are slow to heal.

Treatment utilizes calcium EDTA for skin ulcers.

Lead

Lead is a very malleable, heavy, useful metal. It is absorbed via inhalation of dust or lead oxide fumes, or by ingestion. Dust comes from sanding of lead-based paint. Fumes come from the gas cutting of metal. Ingestion may occur from any number of ways.

Lead poisoning is essentially a chronic disease caused by the gradual accumulation of a significant body burden. One of the most important sites of the toxic action of lead is the inhibition of the heme biosynthetic pathway. Blood lead levels are measured for assessing acute exposure. Efforts must be made to keep the blood lead level less than 40 micrograms per 100 ml. Accumulation of zinc protoporphyrin (ZPP) is used effectively as a diagnostic test for lead exposure (a measure of the biological effect of lead averaged over a three month interval).

CNS symptoms include convulsions, delirium, coma, headache, dizziness, sleep disturbances, memory deficit and changes in personality. Progressive renal disease is possible. Some of the most frequent symptoms are GI; including nausea, anorexia, weight loss, epigastric discomfort, dyspepsia, and abdominal cramps (lead colic). The "lead caper": Colic, Arthralgia, Polyneuritis, Encephalopathy, Red blood cell stippling and anemia.

Within the Navy, lead-based paint is very common and sanding can cause airborne exposure. Finished lead products are safe in normal use. Heating, grinding, spraying, or burning may result in emission of biologically active forms of lead. Consideration of lead exposure is important in the demolition of ships because of lead-based paint.

Treatment consists of discontinuing exposure and CaEDTA (calcium ethylenediaminetetraacetic acid).

Nickel

Nickel is an elemental metal of little toxicity as the metal, but with many toxic compounds. Ni is a trace element needed for life. Nickel carbonyl, Ni(CO)₄, is especially noted for cancer induction. Absorption occurs via inhalation of the compounds (primarily in nickel refinery workers). Gas welding nickel-plated materials may result in metal fume fever. Ni(CO)₄ produces immediate nonspecific symptoms which soon disappear. Severe respiratory distress develops hours or days after exposure as a result of chemical pneumonitis. Death is usually the result of interstitial pneumonitis. Cancer of the respiratory tract, including nasal cavity, sinus cavities, and lungs may occur.

Toxicology

Cigarette smoke has nickel carbonyl. A lot of nickel-plating is done in industry. All chrome plating has nickel under it. It is also found in nickel cadmium batteries.

Mercury

Mercury, Hg, is an elemental metal liquid at room temperature and fairly nontoxic as the metal. The vapor is toxic and some compounds are real problems. Mercury is absorbed by inhalation. Methyl mercury is another bioconcentrator. The renal parenchyma is the principal tissue that is promptly occupied by Hg. Urinary Hg levels remain an important indicator of body burden, particularly when followed over time. Chronic exposure produces the classical triad: erethism, tremor, and gingivitis. Tremor is one of the earliest and most characteristic expressions of Hg toxicity. In the CNS, erethism is described as nervousness, irritability, tendency to resent being observed, timidity, and bursts of quick temper of unusual degree for the individual affected. The CNS is generally the target of acute exposure, whereas, the kidney is the target of chronic exposure. Hg in the urine is a good index of exposure, but not toxicity. The predominant use of mercury in the Navy is by dentists.

Treatment has included dimercaprol (BAL), although penicillamine is preferred. Polythiol resin has been used for the reduction of intestinal absorption of methyl Hg.

Metal Fume Fever

To understand metal fume fever, one must remember what constitutes fumes. The method of absorption is obviously inhalation. Metal fume fever is typical of a flu syndrome with fever, chills, and malaise. It usually lasts 6 to 12 hours, but in severe cases can result in severe respiratory embarrassment. Metal fume fever results from the welding of nonferrous metals, including brass, copper, zinc, and magnesium.

Asbestos

Asbestos is a generic term for naturally occurring fibrous minerals. The fibers are made up of fibrils which are not visible to the optical microscope, but are to the electron microscope. Serious toxicity is from inhalation. Visible fibers break into fibrils in the lung.

There are three major distinct syndromes: (1) asbestosis, (2) lung cancer, and (3) mesothelioma. Asbestosis is diffuse interstitial fibrosis with a small tight lung. This is due to massive exposure to the airborne fibers. This is the most common disease state associated with exposure. However, lung cancer is the most common cause of death. This is induced by embedded fibrils in the lung.

Asbestos workers have ten times the lung cancer death rate of non-asbestos workers from lung cancer, all other things being equal. Smokers add a multiplier of eight to this increased risk. Mesothelioma was previously extremely rare and has increased to fairly common in asbestos workers. This is what is called a signal neoplasm in preventive medicine.

Previously ships were full of asbestos, however, new ships have very little. Ripout and breakup of old ships is quite hazardous.

In summary, asbestos is a very common mineral fiber. Detailed safety procedures are necessary when working with asbestos. Latency of disease make cause and effect difficult to measure.

Silica

Silica is common sand, SiO_2 . Absorption occurs via the inhalation of the fume dust. This is common with sand blasters and miners. The most common clinical syndrome is diffuse interstitial fibrosis due to chronic exposure. Progression of the fibrosis may occur even after removal from exposure. Look for a decrease in vital capacity.

The fear of silicosis makes sand blasting in the shipyard a difficult and extremely expensive proposition. Therefore, old paint is removed by sailors with sanders using thousands of man-hours in relatively difficult and dangerous work.

Plutonium

Plutonium is an artificially produced radioactive solid made by bombarding U_{238} with neutrons. Plutonium is an alpha emitter. Inhalation is the only significant method of absorption. Plutonium concentrates in the bone and liver. The major damage is osteosarcoma. Within the Navy, plutonium is found in nuclear reactors and weapons. Chelating agents speed up elimination.

Plutonium creates very high public interest. It is very toxic, very hazardous, and very well controlled. The radiological half-life is 25,000 years. The biological half-life is 200 years.

Dioxin and Agent Orange

Agent Orange is a 50/50 mixture of 2,4D, and 2,4,5T. These are both phenoxyaliphatic acids. In their pure forms, they are relatively nontoxic. However, 2,4,5 is often contaminated with another compound, dioxin (TCDD -- tetra-chloro-dibenzo-dioxin). Dioxin is absorbed by inhalation, ingestion, and direct contact.

Toxicology

The clinical syndrome is caused by dioxin toxicity. It may be associated with a wide variety of clinical syndromes in those with significant exposure, usually industrial workers. Recent studies have suggested that it is not as toxic as had been thought. There is little or no scientific evidence that limited exposure is related to any disease. Major diseases of occupational workers are: chloracne, peripheral neuropathy (especially lower extremities), psychological disturbances, neurasthenia, hepatitis, decreased "helper-suppressor" ratio, and cutaneous anergy.

Agent Orange is the common name for a compound that was used extensively during the Southeast Asia conflict. Primarily employed to deny cover and concealment to the enemy, it was used, on occasion, to destroy food crops. Over 200,000 veterans have claimed disability from exposure, although an extensive Air Force study failed to document cause and effect relationships.

Glossary

PEL - Permissible Exposure Limit. The maximum permissible concentration of a toxic substance (averaged over eight hours) to which an employee may be exposed, by directive. A legal limit that takes into account both chronic and acute effects.

TLV - Threshold Limit Value. A time-weighted average exposure over an eight hour day, five day week, from which no acute ill effects occur. Excursions above the TLV are permitted if properly compensated with appropriate times below the TLV. This is a practical limit developed by industry prior to OSHA, which takes into account only acute effects and contains a generous safety factor.

TLV-C - Threshold Limit Value - Ceiling. A value not to be exceeded even briefly.

STEL - Short Term Exposure Limit. A legal fifteen minute time limited exposure which may not be exceeded.

OSHA - Occupational Safety and Health Administration. A Federal Bureau and a political organization empowered to enforce Federal Safety Standards. It was organized in 1970.

NIOSH - National Institute of Occupational Safety and Health. Responsible for research, development and publishing of standards. This is a scientific organization.

ACGZH. American Conference of Governmental Industrial Hygienists.

Carcinogenesis. The ability to induce malignant neoplasm. Harms a single individual. Effects this generation.

Mutagenesis. The ability to change genetic material. Harms the succeeding generations.

Teratogenesis The ability to cause birth defects by direct effects on the fetus. Harms the next generation.

Vapor. The gaseous phase of a material which is mostly solid or liquid at room temperature (e.g., gasoline).

Aerosol. A dispersion of particles, either solid or liquid, of microscopic size, in a gaseous medium.

Mist. An aerosol of suspended liquid droplets (e.g., fog).

Fume. An aerosol of solid particles (0.1 microns or less) generated from condensation from a gaseous state, usually after volatilization from metals (as a cutting torch on lead).

Smoke. An aerosol of carbon particles (0.1 microns or less) of very small size mixed with droplets of various things.

Dust. An aerosol of solid particles of 0.1 to 5.0 microns (e.g., talc).

Toxic. An inherent capacity to produce illness or injury when in physical contact with a living cell. Toxicity does not necessarily imply hazard.

Hazardous. For purposes of discussion, a substance which is toxic, exposure is reasonably likely, and harmful effects are likely.

Threshold Value. The level below which there is no effect. This involves determining exactly when "approaching zero" is replaced by "zero". Very difficult to define, much less to determine.

Voids. Voids are "unused" spaces aboard a ship that are closed and not ventilated for months at a time. Rust formation consumes available oxygen. They may be entered safely with a source of supplied air or generated oxygen. An organic vapor mask or a bandanna over the nose and mouth is not adequate.

Toxicology

References

- Lu, F.C. *Basic toxicology*. Washington, DC: Hemisphere Publishing. 1985.
- Klaassen, C.D, Andur, M.O., & Doull, J. *Casarett and Doull's toxicology (3rd ed)*. New York: MacMillan, 1986.
- Rom, W.N.,. *Environmental and occupation medicine*. Boston: Little, Brown, 1983.
- Mackison, F.W., Stricoff, R.S., & Partridge, L.J. *NIOSH/OSHA pocket guide to chemical hazars*. Washington. DC: U.S. Government Printing Office, 1978.

CHAPTER 22

EMERGENCY ESCAPE FROM AIRCRAFT

- Introduction
- Escape Systems
- Pre-Ejection
- Dynamics of Ejection
- Airstream Entry
- Parachute Descent and Landing
- Ejection Mishap Summaries
- Pattern of Ejection Injuries
- Special Escape Problems
- Crashworthiness
- Training
- Future Escape and Survival Systems
- References

Introduction

It has always been Navy policy to do the utmost to ensure the safety and survival of Navy aircrew members. An example of this policy is found in the sophisticated escape systems now used in high performance aircraft. To rescue an aviator from a disabled aircraft - one which might be traveling at high speed, totally out of control, and rapidly disintegrating - is a marvelous accomplishment. That it can be done successfully is a tribute to many disciplines and individuals. The engineering sciences contributed basic system designs. Test personnel, at great personal risk, demonstrated that these systems would work. Medical scientists provided the necessary information concerning human tolerance limits and participated directly in early test programs.

There is a continuing requirement for medical personnel in naval aviation to be knowledgeable about aircraft escape systems. Flight surgeons have multiple responsibilities in this regard. First, a flight surgeon must understand the operation of escape systems if he or she is to deliver effective lectures to aviators concerning the stresses placed on the human body during an emergency escape and the proper procedures required to minimize these stresses. A flight surgeon must be prepared to answer questions concerning all of the biomedical aspects of escape.

The second responsibility of a flight surgeon is to have a clear understanding of ejection, crash landing, ditching, and bailout dynamics in order to properly diagnose and treat the unique injuries likely to be received by an aircrew member. An aviator who is suddenly propelled into a windblast of several hundred knots or is involved in a crash can be subjected to unusual and very damaging compression and torsion forces. When a rescued aviator is returned to a carrier or medical facility, the flight surgeon must be able to recognize the injury or possible injury immediately and to deal with it effectively.

A third responsibility for a flight surgeon is *to* seek help in understanding the entire escape process so that system designers can be provided with feedback information concerning Fleet use of escape equipment. Few people can become experts in this extremely complicated arena. There are experts available in the squadron, at the Naval Safety Center, and the Naval Air Systems Command. The Flight Surgeon's Report (FSR) of an aircraft mishap remains a primary source of information concerning the operation and effectiveness of operational escape systems. It is obvious, however, that the real value of these reports is bounded by the knowledge, effort, and care of the contributing flight surgeon.

Escape Systems

There were a number of successful human extractions in Europe in the early part of this century. The first successful American extraction from an aircraft was accomplished by Army Lieutenant Solomon L. Van Meter in a JN4D "Jenny" at Kelly Field in March 1919. Van Meter initiated this extraction by activating a heavy spring-loaded canister which contained the parachute canopy. This action propelled the parachute some 20 feet upward in space and unbuckled his seat belt, clearing him for escape. The force of the wind filled, the parachute and jerked him free of the aircraft (Jones, 1974).

It was not until the advent of high performance aircraft, however, that the development of aircraft ejection and extraction systems began in earnest. Before World War II, it had become obvious that the speeds attained by fighter aircraft made bailout extremely hazardous, if not impossible. Severe windblast prevented individuals from clearing the aircraft and caused premature deployment of parachutes. Excessive G-forces in spinning aircraft often immobilized the occupants, and high sink rates in a power-off configuration often negated any chance of low altitude escape. The Swedes and Germans began developing ejection seats in the late 1930's. The Germans finished their effort in late 1943, and went operational in the later part of 1944. They had approximately 60 combat ejections by the end of WW II. The Swedes went operational in 1945/1946. In 1945, both Great Britain and the United States were developing ejection seats to be used in jet-propelled aircraft. On 30 October 1946, Navy Lieutenant (jg) A. J. Furtek made the

first live test of a U.S. ejection seat when he was safely ejected from a JD-1 flying at about 250 knots at 6,000 feet over Lakehurst, New Jersey.

Ejection Seat Operation

Present Navy ejection seats are highly automated systems requiring that the occupant only pull a firing mechanism control handle to effect escape. Typically, the seat consists of a seat bucket, back, and headrest assembly with an attached ballistic catapult to propel the seat and occupant from the aircraft. A sustainer rocket motor provides additional energy to propel the seat away from the aircraft. Figures 22-1 through 22-4 show some of the seat models flying in current operational aircraft.

The type of seat propulsion, methods of extremity restraint, seat-man separation, parachute deployment, etc., will vary among the different models of ejection seats. After making the decision to eject, the occupant should assume a position in the seat, with buttocks well back and head firmly against the headrest. This position minimizes stress on the anterior portion of the vertebrae during seat acceleration. Generally, escape is initiated by the actuation of either a face curtain or a lower firing handle. The face curtain, located at the top of the headrest, is grasped with the hands, in a chinning position (Figures 22-5). The curtain is pulled over the head and then down over the face with the elbows in. Initial movement of the curtain generally fires a canopy release mechanism and further movement fires the seat itself. There are systems, however, that eject the occupant through the canopy.

Under asymmetrical flight conditions or when acceleration forces exceed 6 to 8 G, the face curtain or lower ejection handle may be difficult to reach or actuate. Occupant injury, blockage of access to the curtain by the occupant's head, or lack of sufficient time could also prevent use of the face curtain. The lower ejection handle, is located between the legs at the forward edge of the seat bucket and is used as another method for initiating ejection. The occupant grasps the handle as shown in Figures 22- 6 and pulls upward to eject. A major design change found on the latest model ejection seats is the elimination of the face curtain, using the lower ejection handle as the sole method to initiate ejection.

As the ejection seat starts up the guide rails, the lower extremities move back against the seat as a result of the inertial loads. Some seats then forcibly restrain them in that position by leg restraints until a seat separator mechanism is actuated. Figure 22-7 shows the leg restraint for the SJU-5/A ejection seat. During seat travel up the rails, the seat mounted oxygen and communication disconnects are separated from the aircraft. As the seat reaches the end of the aircraft guide rails, a rocket motor attached to the underside or back of the seat structure, is ignited. The rocket

assist acts as a sustainer, maintaining thrust after the cartridge actuated catapult tubes have separated. This results in a higher ejection trajectory which assures that the ejected seat-man combination will clear aircraft structures, such as the tail, during high speed ejections. The higher trajectory is also necessary during low speed and zero-zero (zero velocity and zero altitude) ejections to provide sufficient time for deployment and opening of the personnel parachute.

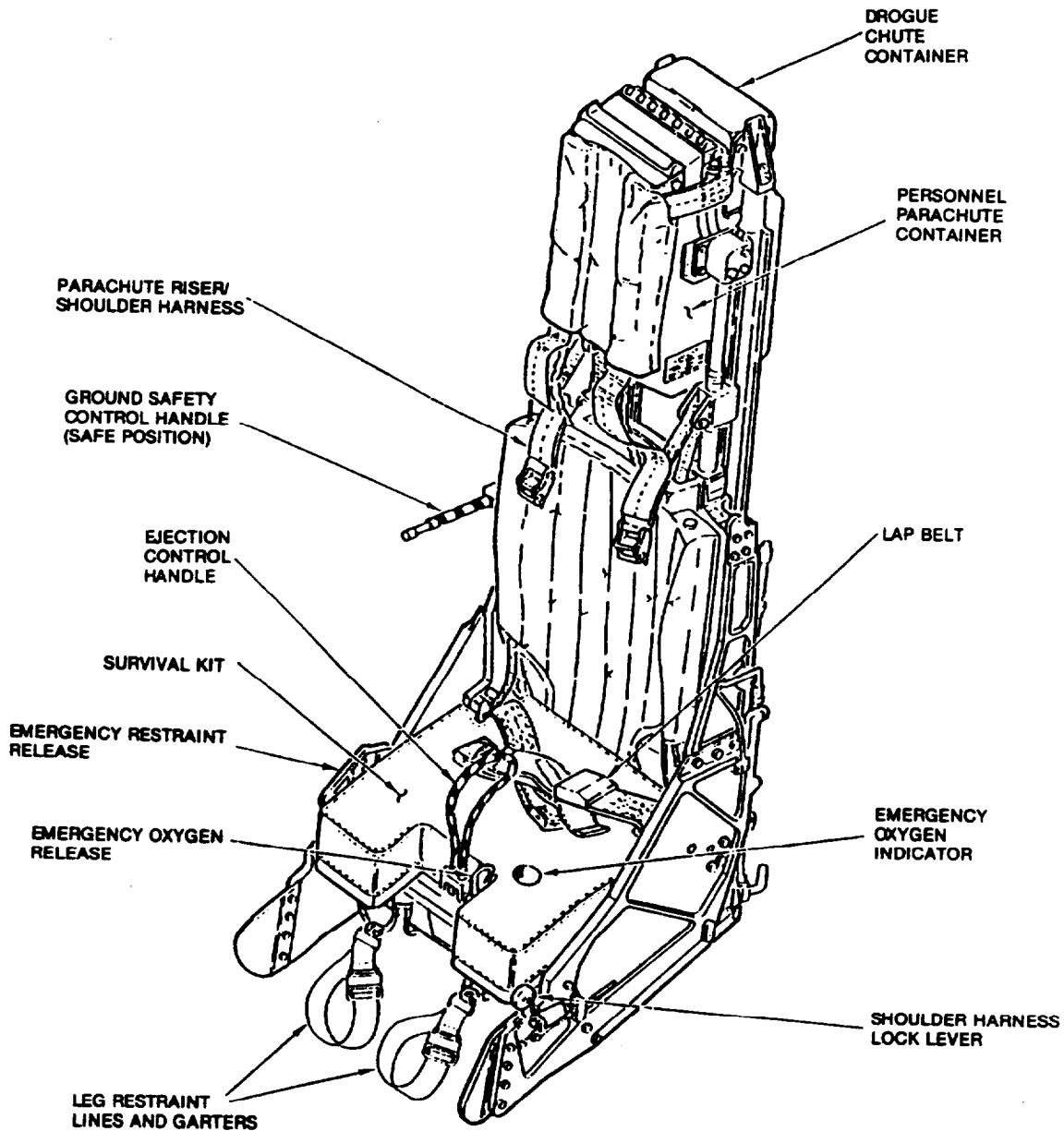

Figure 22-1. AV-8B, SJU-4/A ejection seat.

Emergency Escape from Aircraft

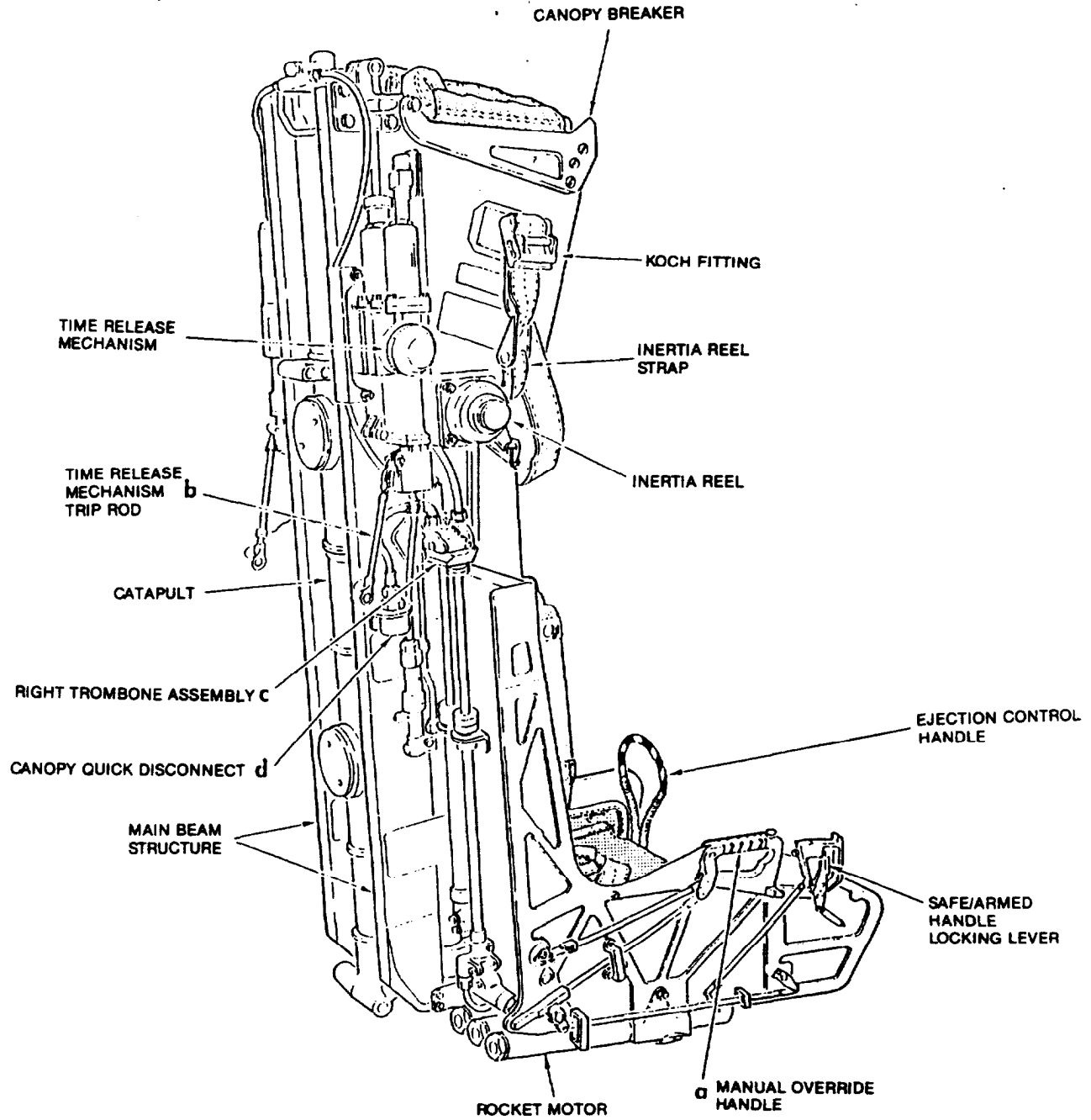

Figure 22-2. F/A-18, SJU-5/A ejection seat.

EJECTION SEAT, SURVIVAL KIT, SEAWARS AND PARACHUTE INSTALLED

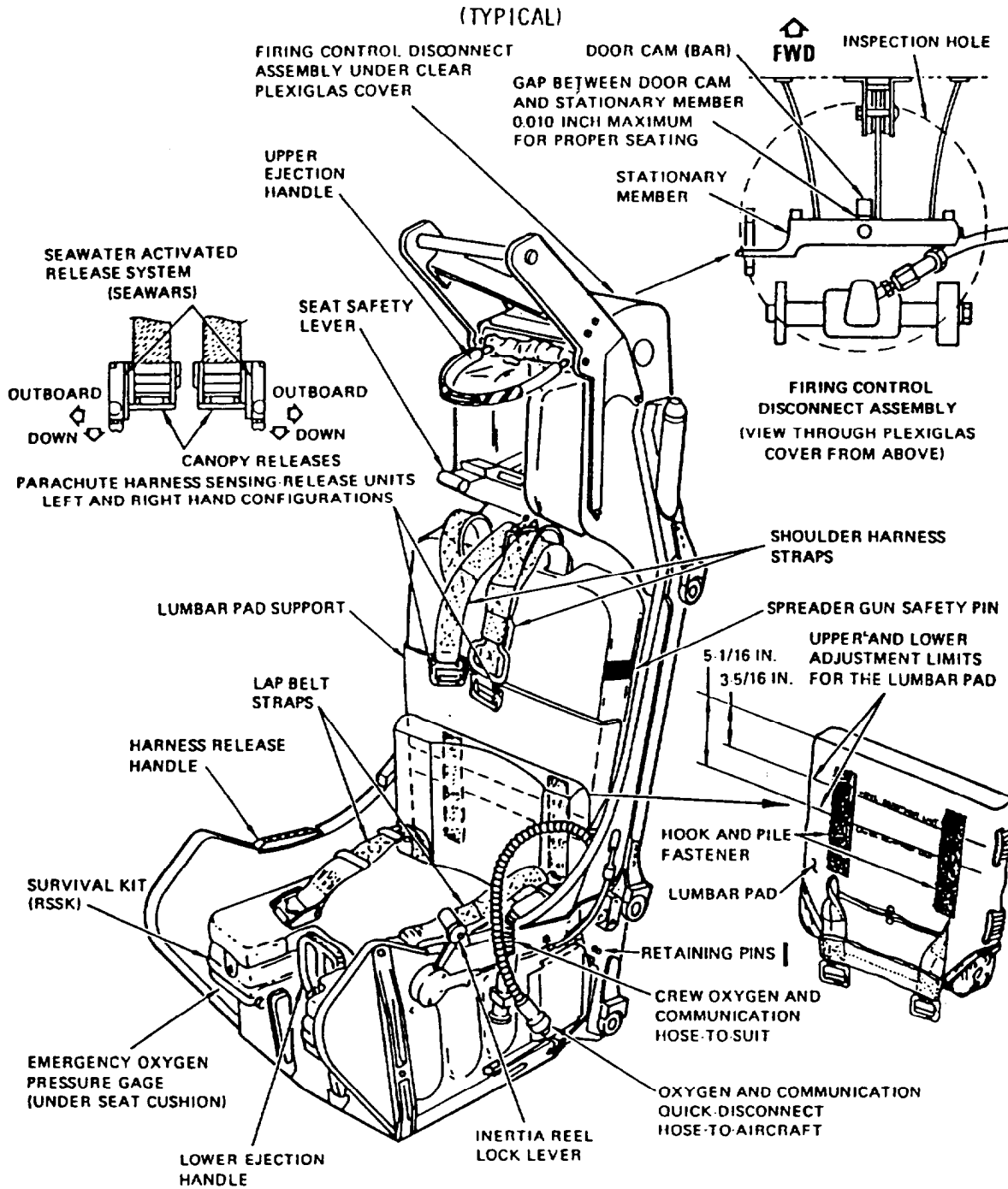

Figure 22-3. S-3, Escapac IE-1 ejection seat.

Emergency Escape from Aircraft

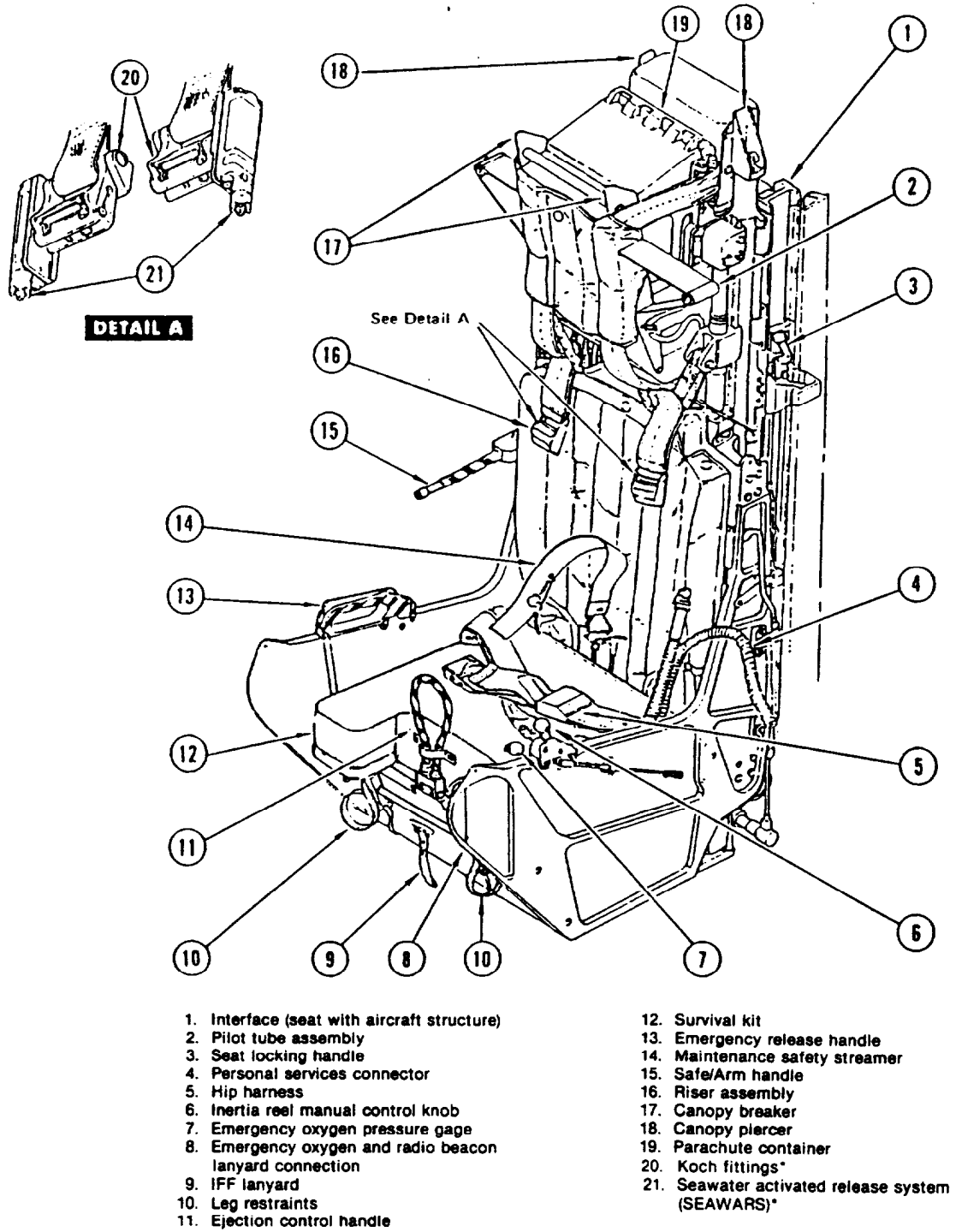
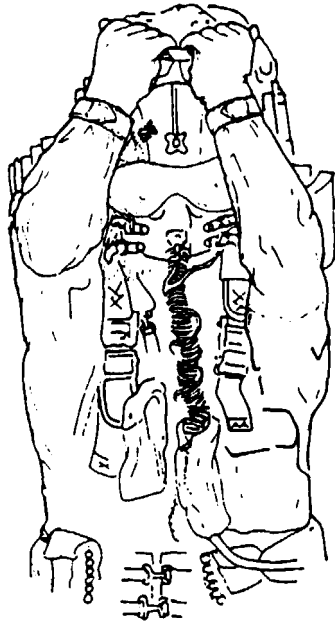
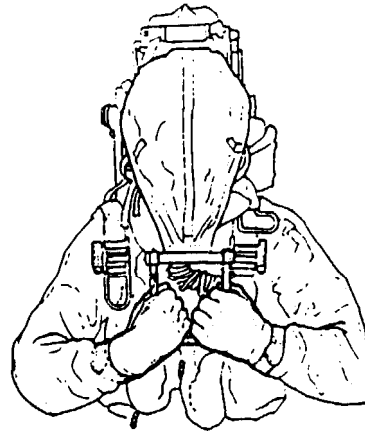

Figure 22-4. A-7, SJU-8A ejection seat.

FACE CURTAIN



1. Grip upper handle, palms toward body, using "thumbs around handle" grip. Keep elbows as close together as possible.



2. Pull curtain sharply over head and into chest. Ensure pulling handle to end of travel. Keep elbows as close to torso as possible.



3. If the seat fails to eject after pulling the face curtain handle, continue to hold the face curtain handle with one hand while grasping the lower ejection handle with the other hand and pull up firmly.

22-8

Figure 22-5. Ejection initiation with face curtain.

LOWER EJECTION HANDLE



1. Grip the ejection handle with the thumb and at least two fingers of each hand, palms toward body, and elbows close to body.

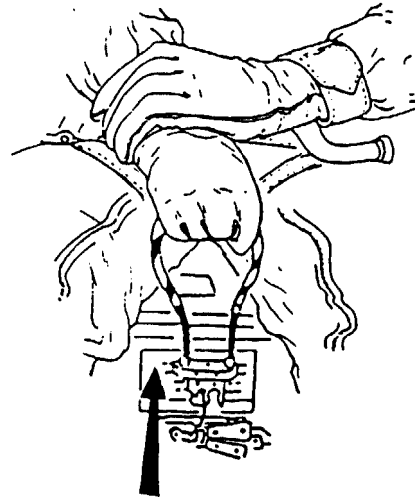

2. Pull handle sharply up and toward abdomen, keeping elbows in. Ensure handle is pulled to end of travel.

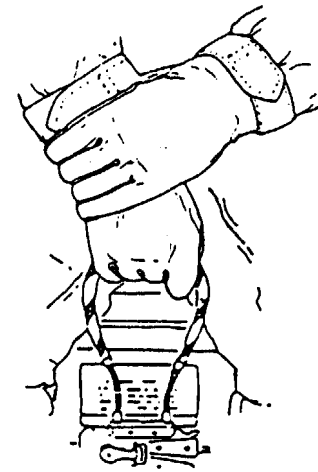

- OR grip handle with strong hand, palm inward. Grip wrist of strong hand with other hand, palm toward body, and elbows close to body.

22-9

Figure 22-6. Ejection initiation with lower ejection handle.

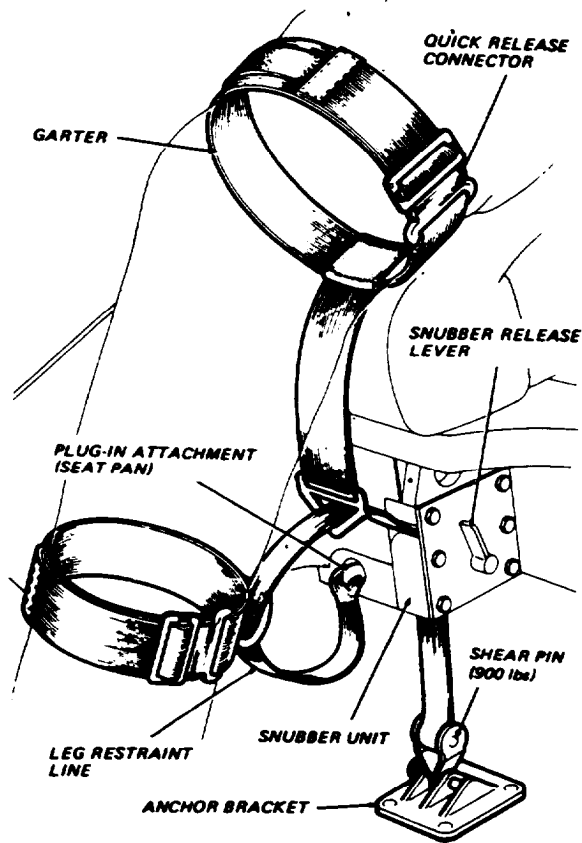

Figure 22-7. Martin-Baker ejection seat leg restraint (double garter) configuration (Courtesy of Martin-Baker Aircraft Co. Ltd.).

An important attribute of a rocket assisted ejection is that the acceleration during ejection can be maintained at a safe physiological level while propelling the seat out and away from the aircraft. If the rocket were not available, a much higher acceleration would be required of the catapult to obtain the trajectory height needed to save the occupant under zero-zero ejection conditions. Human acceleration tolerances could be exceeded, especially if the occupant was out of position at the moment of ejection. This is especially true with the older systems, but is not true for all the systems in use today.

Current Navy Ejection Seats

Navy aircraft currently use a variety of ejection seats. Table 22-1 lists those seats that were in the Navy inventory in the late 1980's and identifies the model and manufacturer. Each seat model

Emergency Escape from Aircraft

usually has some unique feature which makes it different from any other model within its series. Often, however, only the dimensions are different to permit installation in specific aircraft. In many cases new technology and changes are added as retrofits to meet the requirements of the aircraft and to upgrade performance. The flight surgeon must recognize that configurations and performance characteristics of ejections seats vary greatly among seat models within any series and between manufacturers. A detailed description of each specific escape system is found in the *NATOPS Flight Manual* or *Maintenance Instruction Manual (MIM)* for each aircraft. *'Always seek subject matter experts and use an up-to-date manual to obtain information on a specific escape system.'*

Table 22-1

Ejection Seats Used in U.S. Navy Aircraft

Aircraft	seat
A-4	ESCAPAC IG-3
TA-4	ESCAPAC IG-4 and IG-5
A-6	MK GRU7
EA-6B	MK GRUEA7
A-7	SJU-8A
TA-7	SJU-11/A and SJU-12/A
AV-8B	SJU-4/A
TAV-8B	SJU-13/A and SJU-14A
F-4	MK H7
F-14	GRU7A
F-18	SJU-5/A
TF-18	SJU-5/A and SJU-6/A
F/A-18	SJU-5/A
TF/A-18	SJU-5/A and SJU-6/A
OV-10	LW-3B
s-3	ESCAPAC IE-1
T-2	LS-1A
T-45	NACES

Restraint

A combination of both passive and active restraints are used to maintain the position of the occupant in the seat during both flight and ejection. An active restraint is one that physically operates during the escape sequence. A passive restraint is one that requires no action on the part of the seat occupant. An example would be the contour of the bucket used to retain the upper legs and thighs.

As currently configured, a portion of the occupant's restraint harness is seat-mounted and a part is man-mounted. The occupant wears a Parachute Component Unit (PCU) which is a parachute restraint harness assembly (known for years as the MA-2 torso harness) which is donned in the ready room. There are currently sixteen different sizes of this garment in the Navy inventory and smaller aviators can also obtain a custom fitted harness. Since the harness is comprised of an adjustable continuous strap, it is extremely important that the crew member be fitted with the correct size to eliminate any excess slack during the ejection event. A tight coupling between the occupant and the seat helps to keep the dynamic response and acceleration "over shoot" of the occupant within tolerable limits. Once the aviator is seated in the aircraft, the seat's lower lap belt fittings (referred to for years as the mini-Koch fittings) are attached to their mating fittings on the PCU torso harness. If the seat contains leg restraint straps, they are attached to the leg garters. The upper seat parachute release fittings (known for years as the upper Koch fittings) are then attached to their mating hardware on the PCU torso harness. With the shoulder harness inertia reel handle in its locked position, all straps are then adjusted tightly.

The ballistic powered shoulder harness inertia reel is mounted to the back of the seat with its straps connected to the parachute risers which in turn are attached through the parachute release fittings to the occupant's upper portion of the PCU torso harness. Manual locking and unlocking of the reel is controlled by the shoulder harness lock/unlock handle on the left side of the seat bucket. In its auto lock position, the occupant is able to freely rotate the upper torso forward. During ejection, a cartridge is fired to retract the shoulder harness which helps to position and restrain the occupant for ejection. Under some conditions, it simply tightens the harness, straining against centrifugal or inertial forces acting on the occupant's torso. The seat backrest, head rest, bucket, and sides provide passive restraint in addition to the active restraint harness described above.

Escape Path Clearance

Depending on the type of aircraft, there are several methods for clearing an escape path for the ejecting seat and occupant. In aircraft such as the F/A-18, TF/A-18, F-18, TF-18, and F-14, the

Emergency Escape from Aircraft

canopy is jettisoned before the seat begins its motion up the guide rails. The time delay in waiting for the canopy to move back out of the ejection path is approximately 0.3 seconds. Other seats in aircraft such as the A-6, A-7, OV-10, and S-3 normally eject the occupant through the canopy and the seat is equipped with canopy breakers located on the top of the headbox to mechanically fracture the acrylic. In some aircraft, such as the AV-8 and TA-7, mild detonating cords or other ballistic means are used to fracture or weaken the canopy prior to the seat contacting and passing through the canopy. The flight surgeon must be aware that in ejecting through a canopy there is always the risk of contacting pieces of broken acrylic which can cause cuts and abrasions to the seat occupant. Time must not be wasted, however, waiting for the canopy to be jettisoned on those systems that have this capability. Time usually translates to a loss of altitude and this can have catastrophic results. Injuries associated with through the canopy ejections are generally minor and usually associated with helmet and mask loss or displacement. When mild detonating cord is used to fracture or fragment the canopy there is also a small risk that fragments may be spattered in the vicinity of the ejecting crew member. It is extremely important that the oxygen mask be worn if available, and that the helmet visor be in its lowered position to protect the face and eyes during ejection.

Interseat Sequencing

Some multiplace aircraft such as the S-3, OV-10, EA-6, TA-4, F-14, TF-18, TF/A-18, TAV-8B, T-2, and TA-7 use some type of interseat sequencing to control the ejection event. Its purpose is to assure that there is sufficient post ejection spatial separation between the departing seats to prevent interference between the ejected systems, and to reduce the probability of rocket plume impingement with the occupant of another seat, inflicting burns to them, and damage to their equipment. However, other multiplace aircraft such as the A-6 and TAV-8A have no sequencing system and crew discipline must be relied on for manual interseat sequencing. The actual controlled sequence of events that occurs varies from aircraft to aircraft and the flight surgeon is again directed to consult the experts and latest *NATOPS* Flight Manual for specific details.

Divergence

In multiplace aircraft, there is the possibility that under certain speed and ejection conditions, the departing seats and their equipment can follow trajectories that might result in collision and entanglement between seats, parachutes, and crew members. To prevent this occurrence, the sequence for ejecting the seats is controlled by time delays so that they can be spatially separated. Another effective method is to use the rocket thrust as a means for shortening the in-cockpit delay while achieving the requisite lateral divergence between the seats. The four ejection seats in the S-3A each have a small yaw thruster and an aerodynamic vane on their sides. The two aft seats

eject together 0.50 seconds before the two forward crew seats are ejected as a pair. This time delay and the lateral divergence produced by the vane working in conjunction with the yaw thruster ensures adequate separation. Some types of ejection seats, when used in multiplace aircraft such as the TA-7, also use a short time delay between ejecting the forward and aft seat as well as a slight delay in igniting one of the two side-mounted seat back rockets on the seat to impart, and later correct, a seat roll to obtain the necessary spatial separation and lateral divergence. The rocket motor inboard nozzles of three seats in the EA-6B aircraft are oversized to provide approximately 10° to 14° divergence from the vertical depending on the seat position in the aircraft. The fourth seat has symmetrical nozzles giving it a vertical trajectory with little lateral divergence.

Seat-Man Separation

At the appropriate time in the ejection sequence, the occupant's shoulder harness restraints, leg restraints (if included), and survival kit are released from the seat. This is accomplished by mechanical linkages operated by a timed release mechanism (TRM) in the Martin Baker seats. In these seats, the snatch force at line stretch and subsequent opening shock of the main parachute pulls the occupant and survival kit free of the seat.

In certain seats, as aerodynamic drag is imposed on the deploying personnel parachute, tension is exerted on a lanyard sewn to the riser assembly which fires a cartridge producing gas pressure to operate an inertial reel guillotine. The guillotine serves the inertial reel shoulder straps, releasing the crew member's upper torso from the seat. Simultaneous actuation of the seat-man separation mechanical linkage by the riser assembly lanyard releases the survival kit and leg restraints from the seat. The occupant and survival kit are then withdrawn from the seat assembly by the aerodynamic drag on the parachute. There is a backup to this system (i.e., opening shock peeling forces break the stitching between the straps and risers).

The ESCAPAC seats use a harness release actuator which is activated by gas pressure from a booster initiator (or, in older models from a small high pressure storage bottle) to release all restraining straps holding the occupant in the seat. At the same time, in more recent models, it fires a retro-rocket (ear burner) located adjacent to the headrest area of the seat. The retro-rocket thrust moves the seat aft and out from under the occupant resulting in seat-man separation. Other seat types use variations of the methods described above.

Parachute Recovery Systems

There are a number of different recovery systems that are used with the seats listed in Table 22-1. In some cases, a mortar deployed pilot chute or drogue is used to stabilize the seat. As

Emergency Escape from Aircraft

shown in Figure 22-8, a typical Martin Baker ejection seat uses a drogue chute that is extracted and deployed to stabilize the seat and extract the main parachute. The ejection seat drogue gun fires a piston deploying the controller drogue. The controller drogue parachute, in turn deploys the stabilizer drogue parachute. The duplex drogue parachute system decelerates and stabilizes the seat.

The SJU-4/A seat in the AV-8B (similar to the SJU-8/A in the A-7), during early seat movement up the rails, uses gas pressure supplied by its catapult tubes to a drogue gun piston to forcibly expel a drogue parachute container for drogue parachute deployment. The seat is equipped with an automatic mode selection system which controls four ejection modes depending on aircraft airspeed and altitude. A Wind Oriented Rocket Deployment (WORD) motor is mounted on the back of the seat. It is connected to the WORD bridle assembly at one end and the drogue suspension lines on the other end. Depending on the selected mode time, the WORD rocket is withdrawn from the seat by the drogue chute aerodynamic drag and fired, or, under low speed ejection conditions, released to fall away and actuate its firing lanyard through inertial forces, extracting the main parachute from its container. As the parachute suspension lines approach line stretch, the parachute drag pulls a lanyard which fires a ballistic spreader gun. The gun radially expels metal slugs attached to suspension lines on the parachute canopy skirt opening the parachute and allowing the canopy to fill quickly. The spreader gun also, during parachute deployment following higher speed escapes, controls the parachute “thrust” to prevent premature admission of high speed air which might cause excessive or damaging opening shocks. Figure 22-9 shows the ejection sequence for the AV-8B recovery system in its low airspeed/low altitude mode.

Navy ejection seats currently employ three general types of active stabilization systems (e.g., drogue parachute, directional automatic realignment of trajectory (DART) brake line, or gimbaled rocket motor (STAPAC) to enhance stability of the ejected seat/man combination to prevent potentially injurious or failure inducing tumbling.

Pre-Ejection

The aircrew member can greatly increase the probability of successful ejection by being knowledgeable about the egress system and personal equipment and their effect on overall system performance. Wearing unauthorized gear can present a real hazard during ejection and can result in injury or fatality. Wearing unauthorized gear that is not properly fitted such as a wrong size PCU (parachute restraint harness) or personal helmet or mask can also lead to injury.

A-6-GRU-7 TYPICAL TRAJECTORY

- 95 PERCENTILE OCCUPANT
- AIRCRAFT STOPPED ON LANDING GEAR

MAX HEIGHT 117 FT. 2.8 SEC.

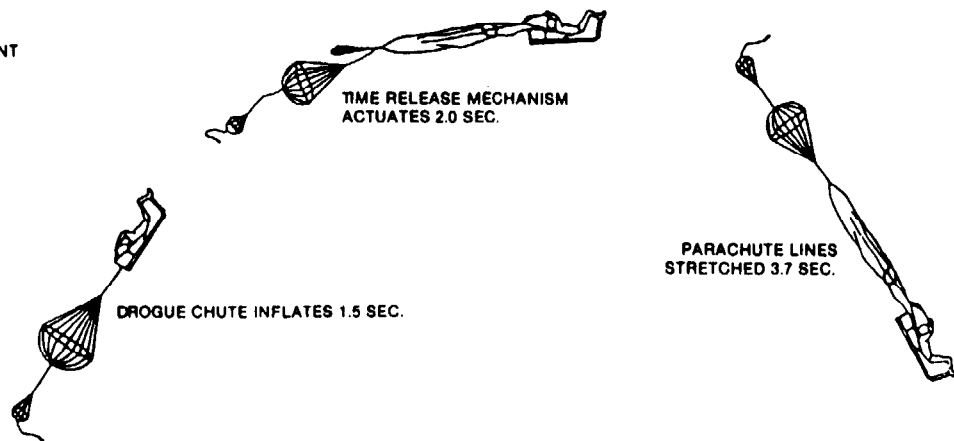

PARACHUTE INFLATION 4.9 SEC.

22-16

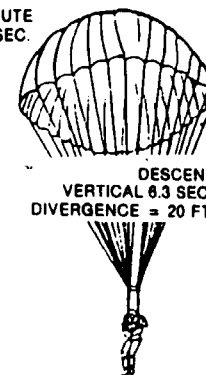
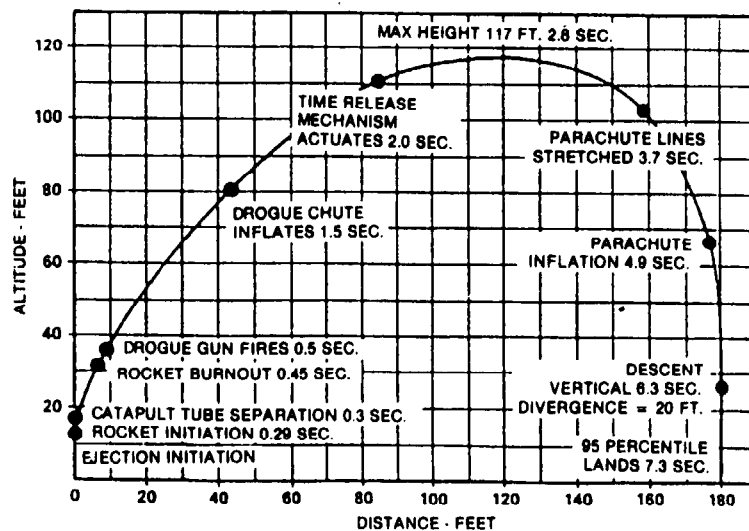
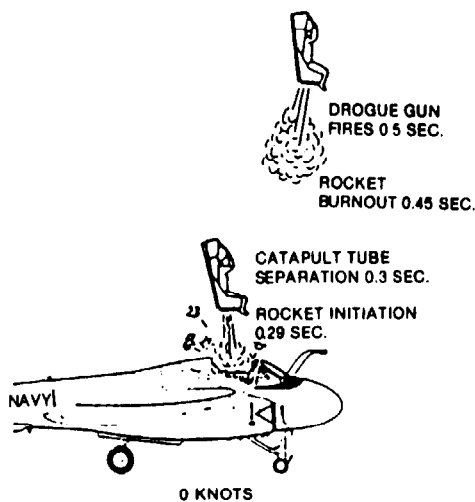

95 % LANDS 7.3 SEC.

ADA1-945

Figure 22-8. A-6, GRU-7 typical trajectory.

Ejection Sequences

LOW ALTITUDE/LOW AIRSPEED

BELOW 225 KNOTS AND BELOW 7,000 FEET

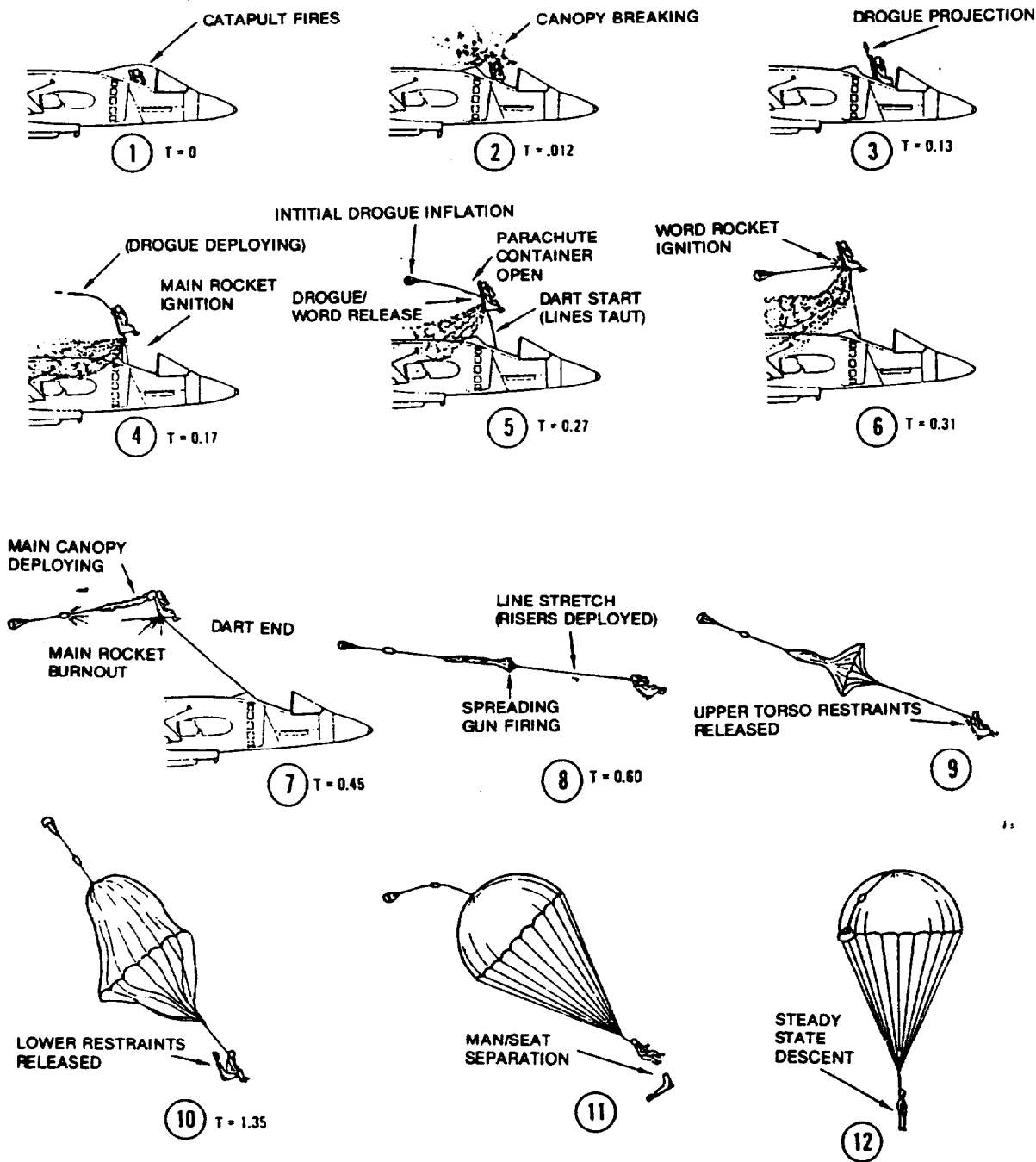

Figure 22-9. AV-8B, SJU-4/A low level, low airspeed ejection sequence.

Pre-ejection is that period of time from initial aircraft emergency until ejection is initiated. During takeoff and landing, low level flights, and in some combat emergencies, this period can be quite short and does not allow for any real preparation prior to egress. During some in-flight emergencies, there may be sufficient time for the aircrew member to do things to increase the probability of lessening injuries and ensuring a successful ejection. Speed can be reduced or sacrificed for altitude, landing terrain selected, emergency communication initiated, and search and rescue forces alerted. If there is time, and other conditions are favorable the aircrew member should ensure that helmet straps are secure, the visor is down and locked, and the oxygen mask is fitted tightly. All harness straps should be tightened, and any loose equipment properly stowed. The aircrew should attempt to have the aircraft in a straight and level attitude at the time of ejection. If the aircraft is rolling and near the ground, ejection should be attempted when the plane is coming upright. However, ejection should *not be delayed* until the aircraft is out of the ejection envelope. Body position is also extremely important. The body should be erect with buttocks against the backrest, head firmly against the headrest, and thighs against the seat pan. A leg fracture may occur when an occupant ejects with one leg raised off the seat pan. Again, however, aircrew must not waste precious time trying to assume a good body position if it might result in delaying too long!

While the time delay prior to ejection can be used to optimize ejection conditions, it has also resulted in numerous unnecessary fatalities. Many studies over the years have shown the danger of delaying too long. Over one-third of the aircrewmen fatally injured during ejections waited until the aircraft was below a safe ejection altitude before initiating their seat system. Delay has been, and continues to be the biggest cause of ejection fatalities. Many out of the envelope fatalities were out of the envelope when the emergency occurred, but many could have been prevented.

During combat operations, the pre-ejection period is extremely critical. Combat pre-ejection injuries are often severe and include disabling wounds from shrapnel, intense burns, and smoke inhalation from cockpit fires. Damage to the aircraft is often catastrophic, with little chance of control, and the aircraft may be disintegrating. If the aircraft is flyable, every attempt is usually made to reach friendly territory. This could result in delaying the ejection until the aircraft is outside the safe escape envelope unless the aircrew remain fully aware of the changing conditions.

Dynamics of Ejection

Each of the two methods used to initiate ejection in Navy aircraft has particular advantages. Use of the face curtain involves pulling it over the helmet and down over the face. This aids in assuming a correct body position, protects the head against windblast, and helps prevent the loss

Emergency Escape from Aircraft

of helmet and oxygen mask. Holding the curtain firmly also supports some of the weight of the shoulder girdle. However, with certain types of injuries, and also under high-G conditions, using the face curtain may be almost impossible. Approximately one-third of the Navy aircrewmembers who ejected during Southeast Asia combat operations used the lower ejection seat handle (Every & Parker, 1977). There is little question that the lower handle is usually easier to reach depending on the flight conditions.

The force required to pull the face curtain is approximately 60 pounds. The force required to pull the lower ejection handle from its receptacle is approximately 45 pounds. However, tests on aircraft have shown considerable deviations from these figures.

The force which propels the seat from the aircraft produces an acceleration ranging roughly between 12 and 16 G, depending on the seat type. Many factors, however, will influence the actual acceleration imposed during a specific ejection. The acceleration of propulsion devices is affected by temperature, the total weight of the occupant-seat assembly (which varies with differences in personnel, equipment, and clothing), and the airspeed, altitude (air density), and aircraft attitude at time of ejection. All will cause variation in the ejection forces actually experienced.

Even though a catapult operates within stated limits, the acceleration forces acting on an aviator may exceed those of the catapult. This is due to the complex mechanical behavior of various parts of the body in relation to each other and the relation of the body to the seat when the occupant-seat system is subjected to ejection forces. The occupant-seat system is a complex mechanical system of rigid (e.g., bone) and semirigid masses connected by elastic elements (flesh, intervertebral discs, internal organs, etc.). When the ballistic force is applied, internal interactions cause time lags as elastic elements absorb energy and then “bottom out” while the compression forces are still acting. Since the seat starts accelerating while the occupant is compressing, the relative velocity increases until the crew member is “bottomed out” against the seat. The occupant then experiences a higher acceleration than the seat (known as “dynamic overshoot”) as he or she accelerates to the same velocity as the seat.

Human Tolerance Limits

Stapp (1955) reported exposures of a human subject to 30 and 30 G eyeballs - out ($-G_x$) at a rate of onset of 500 G per second. The G_x threshold is commonly described as 40 Gs. In these experiments, which were conducted under ideally controlled conditions, the objective was to demonstrate simply that such high forces were survivable. Under more realistic conditions, it has been demonstrated that peak loads of 20 to 25 G ($+G_z$) can be tolerated safely during ejection if

these loads are parallel to the vertebral column and the occupant's head is positioned properly. These tolerances decrease rapidly if the seat occupant is not adequately restrained or is out of position at the onset of acceleration (Kaplan, 1974). The maximum specification limit is now 18 G_z .

Vertebral Injuries

Proper body position when actuating the firing mechanism is extremely important. Good position will prevent forward arching of the head and trunk, which in turn will preclude excessive stress on the anterior portions of the vertebrae. Vertebral fractures have become a frequent injury occurring during ejection. Casual factors associated with these injuries include improper position of the body at time of ejection, varied tension of the restraint harness, inverted or negative G flight conditions at the time of ejection, improper seat and seat back cushioning, offset between body center of gravity and the upward and backward (approximately 18° from vertical) thrust line of the catapult, and through-the-canopy ejection. The 18° mentioned varies considerably from one seat to another.

One of the most vulnerable sites for injury of the spinal column is the region around the eleventh and twelfth thoracic vertebrae (T11-T12). From the eighth thoracic to the first lumbar vertebrae is the region of *greatest* frequency due to the convergence of a multitude of factors. The forward bending movement during ejection is accentuated because the center of gravity of the head and torso is considerably anterior to the spinal plane (Nuttal, 1971).

We can demonstrate a clear relationship between through-the-canopy ejection with higher peak G catapults and the incidence of vertebral fracture. We "know" that improper body position (including a loose harness) increases the risk of injury. The statistics actually do not show any correlation between incidence of inverted ejection and incidence of vertebral fracture, although we would expect a relationship to exist.

Historically, vertebral fractures were very common forms of injury for some escape systems, while those using other types of seats seldom, if ever, sustained such injuries. In more recent times, as the catapult peak G has been reduced, the incidence of vertebral fracture for both through-the-canopy and other ejections has declined dramatically. It is a common but not "frequent" injury type today.

Because of the possibility of spinal injury during ejection, it is recommended that special attention be given to the X-ray examinations of aircrew members who might be required to eject from an aircraft. These exams would hopefully identify individuals with vertebral injuries or malfunc-

tions who would be likely candidates for spinal injury should an emergency ejection become necessary. Rotondo (1975) stresses the importance of a radiological examination following an ejection. Careful attention to this exam is necessary both for immediate diagnosis and treatment purposes and also for detection of any latent degenerative changes which might later affect the aircrewman's safety.

Dynamic Overshoot Effects

Dynamic overshoot, discussed earlier for seat occupants, also occurs within the body. If the time-force characteristics of acceleration and the decay rate are in harmonic resonance with the natural frequency of the occupant-seat system, severe overshoots can be produced within the body. Latham (1957), in a study of body ballistics using various types of seat cushions, found that accelerations of less than 0.2 seconds duration with an onset rate of 400 G per second, produce a maximum acceleration overshoot in the body. A slight increase in the acceleration period, even 0.03 or 0.04 seconds, will result in a minimum overshoot condition.

Early ejection seat experience indicated the importance of the overshoot factor. Test subjects using thick elastic seat cushions suffered injuries more severe than would have been expected for the acceleration to which the seat was exposed. Instrumentation of anthropometric dummies, which do not have the same internal dynamics as the human body, revealed that the cushioning caused extreme levels of dynamic overshoot. Upon ejection, the resilient seat cushion readily compresses, and the seat is well on its way before the occupant has started upward, yet the final velocity of the occupant-seat assembly must eventually be the same. In order for this to occur the occupant then has to accelerate to peak velocity in a shorter period than the seat assembly, resulting in both a greater acceleration and a greater rate of G onset exposure for the occupant. Current seats have rigid seat survival kits (RSSK) or survival kit units (SKU) as the platform upon which the occupant sits. Flight crews should be cautioned not to improvise equipment which might appear to provide more comfort (or improve sitting position), since the unauthorized and seemingly unimportant item might well cause serious injury in the event of an ejection.

Overshoot effects can be particularly severe on internal organs, which have their own dynamic response to catapult forces. Krefft (1974) discusses the various forces and stresses imposed on the internal organs during ejection. These organs may be subject to severe deformation and tensile stresses. During ejection, the vertical acceleration forces may combine with the transverse shock from the ram air pressure. This transverse jolt against the thorax is immediately transmitted to the heart at its location at the anterior internal chest wall. Here, the shock leads to a compression where hemodynamic forces can exceed the elasticity modulus of the tissue, and ruptures may be sustained because of local overstretching. It must be pointed out, however, that these are extremely remote possibilities.

Airstream Entry

The accelerations imposed on the spinal column during ejection represent only one of several stresses to which the aircrew member is exposed in a short time. Within milliseconds after ejection catapult initiation, the seat and crew member enter the airstream, not as a sudden total exposure, but as a relatively gradual partial exposure. As the ejection seat emerges from the cockpit, there is marked differential pressure exerted on the part of the body exposed to windblast as compared with the part still protected by the aircraft structure. While this differential ram air pressure exists only for a very short period, nevertheless, it can be the cause of serious or fatal injury. It has been proposed by some investigators that in some instances, initial exposure of the helmeted head to windblast has caused the helmet to act as a sail, causing fracture of the hyoid bone as the helmet/chinstrap is suddenly impacted against it. This is extremely rare, and scattered among higher speed ejections (i.e., 350 + knots). To minimize this effect, helmets are now often form fitted to the aircrew member's head for a tight coupling. The chin strap and retention system have been improved and the helmet, oxygen mask, oxygen mask suspension, mini-regulator, oxygen hose, and helmet visor are dynamically tested for their ability to withstand windblast.

In some mishaps, the question of helmet rotation (around the axis of the chinstrap attachment points) during exposure to windblast has been raised. It has been suggested that if such rotation occurred, one would expect to find posterior fractures of cervical vertebrae, with or without cord injury. Such injuries have been noted in isolated instances, but may have been due to other causes. The problem may or may not exist. More often, an improperly fitted helmet or loose chin strap causes the helmet to be blown off injuring the aircrewman and/or leaving the aircrew member unprotected against obstacles upon parachute landing. While these could be casual factors for losing helmets, examination of the data suggest that such factors need not enter the picture. Helmet loss clearly is a function of ejection airspeed. Recovered lost helmets have often shown that the helmet, mask, and retention system were properly fitted and tight. One needs to recognize the extreme flexibility and deformability of the chin and lower jaw relative to the skull and the wide variation in skull shapes in this particular problem.

Windblast

After the initial +G_z acceleration of the catapult and the differential $\pm G_x$ acceleration of "gradual" entry into windblast, the entire body and seat combination is subjected to 20 -G_x (eyeballs out) deceleration due to ram air force from windblast. Again, this is only true for some seats. Others have combinations of pitches or even tumbling. This force (Q-force) is proportional to the surface area of the occupant-seat combination and the differential velocity of the occupant-seat combination and the air in which it moves. Thus, both the airspeed and altitude at

Emergency Escape from Aircraft

the time of ejection are important variables. The higher the airspeed and the lower the altitude, the greater will be the ram air force (Q-force) applied to the occupant-seat combination. For all practical purposes, the pressure (stated in pounds per square foot or Newtons per square meter) is the density of the air (in slugs per cubic foot or kilograms per square meter) times the velocity of the air (in feet or meters per second) squared. Q-forces are thus related to indicated airspeed rather than true airspeed. The following formula expresses Q-force versus speed. This relationship, expressed in metric units, is graphed in Figure 22-10.

$$\text{Q-force} = QA \text{ where } Q = 1/2\rho V^2$$

Q-force = force in Newtons

Q = dynamic air pressure in Newtons/meter² (N/m²)

A = area in M²

ρ = air density in kg/m³

V = velocity in meters/second

The important fact to note is that the Q-force increases as the square of velocity.

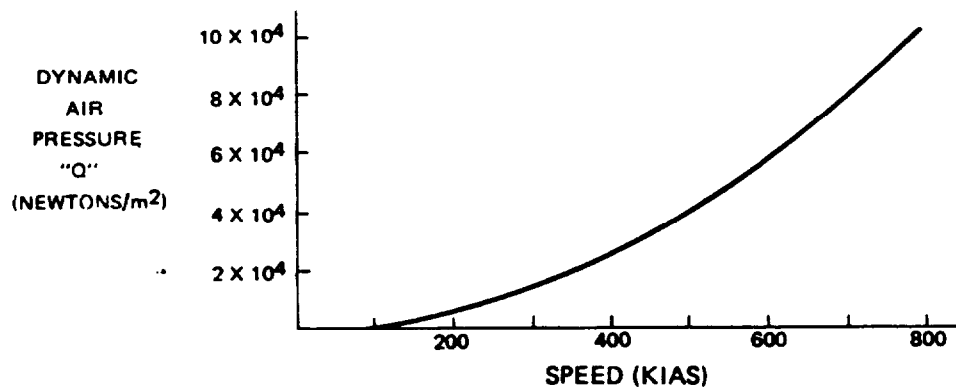

Figure 22-10. Dynamic air pressure vs. airspeed (Ring, Brinkley, & Noyes, 1975).

Therefore, when possible, pilots should reduce the aircraft speed and increase altitude prior to ejection. Air density changes very little with the likely altitude change and usually wouldn't be a significant factor.

Abrupt entry into the airstream at high speed causes formidable stresses. For example, at an altitude of 5,000 feet and a true airspeed of 600 knots (.9 Mach), the ram air pressure encountered is about 1,050 pounds per square foot. This means that a person presenting approximately 6

square feet of frontal area will receive a total ram force (Q-force) of 6,300 pounds or approximately three tons of ram air force. But, the drop off is rapid. $F = ma$, due to the relatively small ejected mass, where $F =$ force, $m =$ mass, and $a =$ acceleration. Further, not many seats present a full frontal aspect to the wind and, those that do, do so with the additional drag area of a drogue, causing rapid man-seat velocity decay with corresponding rapid Q-force fall-off. A zoom climb is a valuable exchange of speed for altitude, reducing the ejection airspeed and its manifold associated undesirable effects and gaining time for the system to work (the primary value of the altitude gained in this manner). However, we have entered another era entirely. Escape data indicate very strongly that uncontrolled flight is becoming our aircrew's primary emergency requiring escape. Thus, for the vast majority, the problem is one of initiating ejection soon enough, as they will be unable to zoom climb.

It is important to note that it is not Q-force per se which causes the major injuries associated with high-speed ejection. Payne (1975) cites examples of persons exposed to dynamic pressures of $4.8 \times 10^4 \text{ N/m}^2$ (20.9 PSIA) without serious injury. There are, however, two distinctive injury patterns associated with higher Q-forces. The first, generally referred to as true windblast, normally results in only minor injury to soft tissue. The second type, commonly referred to as flail injury, results from the summation of forces over larger areas producing differential decelerations of an extremely relative to the torso and seat (Ring, Brinkley, & Noyes, 1975). But this is only part of the picture. It has been demonstrated that centrifugal forces come into play as well and have been especially significant in ESCAPAC systems. Tumbling in a Q- field produces not only differential drag and centrifugal force but results in alternating (pulsating) differential drag forces more likely to move limbs and, also making it more difficult to protect against injurious movement of limbs. Glaister (1965) states that the different effects of Q-forces can be divided into those produced by windblast, which result in such injuries as petechial and subconjunctival hemorrhage, and those produced by flailing of the head and extremities. Head flailing might cause unconsciousness, while flailing of the arms and legs can lead to fractures (generally the consequence of impacting seat structure) or joint dislocations. When the body is unsupported, a dynamic pressure of approximately $3 \times 10^4 \text{ N/m}^2$ (4.9 PSIA) or more can lead to flailing that cannot be controlled by muscular effort. The onset of flailing can be so rapid that muscular reflex action is ineffective, even at dynamic pressures $3 \times 10^4 \text{ N/m}^2$ (4.9 PSIA). At dynamic pressures of $3.7 \times 10^4 \text{ N/m}^2$ (5.4 Psia), full abduction of an unconstrained hip joint can take place. At greater dynamic pressures, the loads exerted upon unsupported limbs might exceed the strength of the associated major joints. Another factor, sometimes termed "windblast erosion," is the effect of the air pressure on protective clothing and equipment. Clothing has been torn, shoes pulled from the feet, helmet visors shattered, helmets lost, and parachutes prematurely deployed, the last usually with fatal results. However, with today's systems, premature parachute deployment no longer seems to occur.

Emergency Escape from Aircraft

From experience gained in wind tunnel and rocket sled tests, survivor accounts, and also Flight Surgeon Reports, many improvements have been made to enhance the integrity of aviation life support equipment during high-speed, low altitude ejection. The Naval Safety Center, Norfolk, developed and maintains a data base utilizing the information collected and presented in each Flight Surgeon's Report. This data base is actively and continuously examined in attempts to understand how well or how poorly individual elements of aircrew life support system (ALSS) equipment perform under what emergency conditions and why. Much has been learned and can be learned through diligent statistical and engineering analyses of populations of the cases contained in the data base. This underscores the critical importance of adequate and accurate mishap reporting, even in cases where the loss or malfunction of an item of equipment was not a direct cause of injury.

Limb Flail

During high-speed ejection, it is the "differential deceleration" of the extremities relative to the torso and seat which is one of the primary causes of extremity flail. Flail injury occurs because the arm(s) or leg(s), after having broken away from their "stowed" or initial positions, build up a substantial velocity relative to the torso and seat before reaching a "stop." This "stop" may be part of the seat structure, the limit of travel of a joint, or a combination of both. At high speeds, the "stop" is encountered with such force that bone fracture or joint derangement results (Payne, 1975).

The high percentage of extremity flail injury found with combat escape in Southeast Asia was closely related to ejection speed. Almost 50 percent of the Southeast Asia combat ejections were above 400 KIAS as compared to only 5 percent for noncombat ejections occurring during this same time period (Figure 22-11). The correlation between high-speed ejection and flail is readily apparent when these speeds are plotted against frequency of flail injuries (Figure 22-12).

The use of extremity restraints is one of the best solutions for preventing flail with open ejection seats. Aircrew members, however, have been reluctant to wear active restraints, especially those for the upper extremities. Alternatives, which include passive entrapment nets, are currently being looked at as more acceptable means to prevent flailing. These too, necessarily have limited effectiveness under certain conditions. The grasping of the face curtain provides some relief from total arm flailing. However, there have been instances of elbows moving outward and away from the trunk. This "butterflying" has caused both arm and shoulder injuries and has been a major reason why the latest ejection seats have eliminated the face curtain and use a lower "D" handle. The use of active leg restraints such as those found in the F-14, F-18, FA-18, A-6, A-7, AV-8B, and other aircraft have been more widely accepted and are effective in forcibly capturing and

restraining the legs against the front of the seat bucket as it moves up the guide rails. However, there are still occurrences of flail injuries with these systems too.

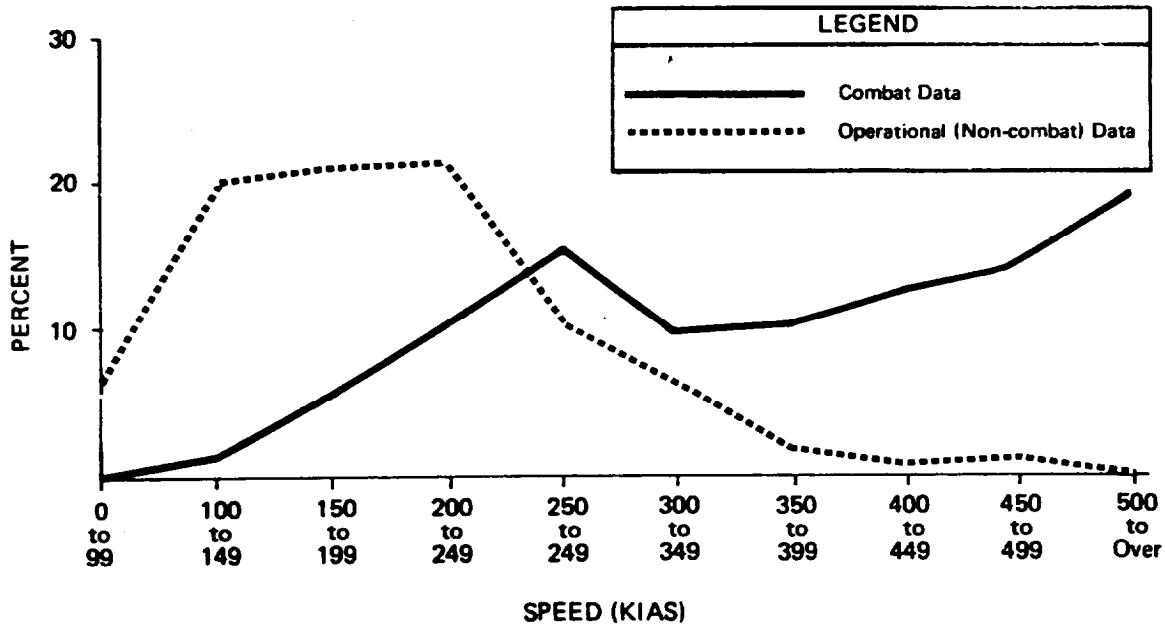

Figure 22-11. Combat vs. operational ejection speeds (Every & Parker, 1977).

Temperature Exposure

Mishap experience with ejection systems indicates that exposure to low ambient temperatures is of little significance as long as standard protective flight clothing, and items of protective equipment are properly fitted, correctly worn, and neither damaged nor lost during ejection.

The high temperatures which can be caused by the ram air rise effect at hypersonic speed have not been experienced as yet in emergency ejections. Aerodynamic heating is certainly a factor during the reentry phase of spacecraft operation. At high Mach numbers, the temperature rise is very severe, approximately 75 times the square of the Mach number (for Fahrenheit scale). This is compounded by the low heat exchange factor which exists in the rarified higher altitudes.

Windblast tests of large animals (chimpanzees) on high-speed rocket sleds have produced severe third-degree burns on exposed body areas. These tests were conducted at a Mach number of 1.7 with a total windblast exposure of 10 seconds (during acceleration and decay of the sled)

Emergency Escape from Aircraft

and exposure of 1 second at peak velocity: Measured surface temperatures were 300° to 320° F, but these alone would not have accounted for the injuries. The total transfer of heat due to the high airstream velocity was noted as the causal factor (Nuttall, 1971).

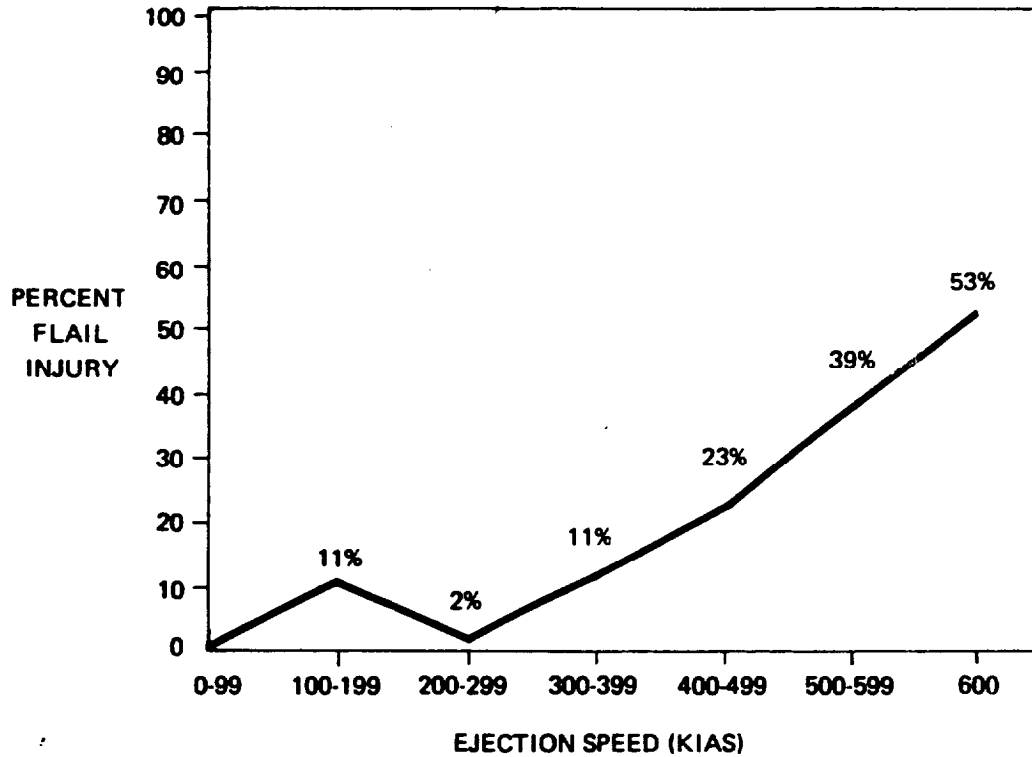

Figure 22-12. Incidence of major flail injury vs. ejection speed (Every & Parker, 1977).

It is doubtful that current open ejection seat systems will be used in hypersonic vehicles. Rather, some form of closed escape module or protective shield will be used to counter thermal and high Q threats.

Tumbling or Rotational Stress

The head-over-heels tumbling which can occur while an aircrew member is still attached to the seat is closely associated with the problem of windblast and wind-drag deceleration. Tumbling is particularly hazardous at high altitudes where combinations of tumbling and spinning in all degrees of freedom of rotation can occur. Walchner (1958) conducted dummy drops from 83,000

feet which indicated that the human body can develop a spin rate as high as 465 rpm. Weiss, Edelberg, Charland, and Rosenbaum (1954) utilized a spin table to investigate animal and human reactions in order to establish tolerance limits. These tests showed that with the center of rotation at the heart, unconsciousness occurred in humans in 3 to 10 seconds at 160 rpm. Indications are that spin rates of more than 400 rpm are fatal to humans.

It is believed that the fatal rate of 400 rpm can be attained during free fall. Navy mishap experience does not indicate that this has been a problem in ejections to date. This is attributed to the infrequent occurrence of high altitude high-speed ejections and also to the fact that the drogue parachute tends to stabilize the seat during its fall (for those systems that have a drogue chute).

Walchner (1958) reported tumbling and spinning experiences of parachutists with rates as high as 240 rpm. This would produce a radial acceleration force of approximately 37 G at eye level, which would be capable of producing severe retinal or cerebrovascular damage.

Spinning and tumbling will cause a combination of positive and negative accelerations, the effects of which will vary with the location of the center of rotation. When the heart is the rotational center, cardiodynamic and general circulatory effects are maximal. Animal studies have shown that at 150 rpm, with the heart the center of rotation, the arteric-venous (A-V) pressure difference and pulse pressure are reduced to less than 5 millimeters of mercury, and cardiac output is nil. Tissue anoxia results, and cerebral hemorrhage from damaged vascular walls can occur as spinning ceases and very high systolic blood pressure overshooting occurs. Circulatory impairment is not serious in humans at 125 rpm.

Hydraulic effects are greatest at those regions which are farthest from the center of rotating. When the center of rotation is located at the lower part of the body, conjunctival hemorrhage, periorbital edema, and hemorrhage into the sinuses and middle ear may occur. The thresholds of petechial hemorrhage of the conjunctiva have been determined. With the center of rotation at the iliac crest, the values vary from 3 seconds at 90 rpm to 2 minutes at 50 rpm. With the center at the heart, the ranges are from 4 seconds at 120 rpm to 10 minutes at 45 rpm.

Ejection seat tumbling has become a less serious problem due to the effectiveness of stabilizer drogue chutes, bridle assemblies, and supplementary control rocket thrusters, which compensate for misalignment and tend to prevent tumbling and uncontrolled spinning. There are still a few systems without stabilizing drogues in the fleet, however.

Parachute Descent and Landing

The Parachute

All escape systems use a parachute to lower personnel to the surface at a safe vertical velocity. In referring to parachutes, the alphanumeric designation of the assembly is used, such as NB-7 or NES. (Some newer systems are referred to as A/P types). The pack type (back, seat, or chest) may be noted. The canopy size and shape may also be mentioned in terms of diameter of the canopy skirt (28-foot flat, 26-foot conical, etc.) Personnel parachutes consist of four primary parts: canopy, pack, suspension lines and risers, and harness. Supplementary parts may include, an internal pilot chute, an external pilot chute, or a ballistic spreader gun.

All personnel parachutes have a smaller parachute (the pilot chute) attached to the apex of the main parachute canopy. It deploys first, sometimes being forcibly opened, and extracts the main canopy from its pack. Some systems incorporate stabilizing drogues which are released from the seat. These drogues then deploy the main parachute. This assures rapid, predictable deployment (within very wide bounds) of the main canopy. Parachute deployment may be accelerated by drogue chute extraction. In some systems, at low airspeeds, the main parachute canopy is opened more rapidly through the use of a ballistic spreader gun, which, in effect, is a ballistic gas powered, positive chute-opening device which provides forced symmetrical opening of the main parachute canopy, and also forcibly precludes premature, possibly asymmetrical opening of the main canopy (see Figure 22-9).

Flight surgeons must familiarize themselves with the specific parachute assemblies in use by their units through visits to the parachute loft. Aircrew survival equipmentmen (parachute riggers) are well aware of their responsibilities, well versed in the capabilities and limitations of survival and safety equipment. They are willing to discuss equipment items with interested personnel and to demonstrate its use when possible.

Parachute Opening and Descent

Parachute opening shock can be severe if escape conditions are such that the drogue parachute either malfunctions or the main parachute deploys prematurely. Opening shock is a fascinating phenomenon that is influenced by airspeed, altitude, and the inflation of the parachute's canopy. The higher the altitude for a given speed, the higher the opening shock will generally be. The higher the speed, the higher the opening shock will generally be. Asymmetrical inflation of the canopy produces high localized stresses in the canopy, premature inflation results in a larger than normal mass (i.e., including trapped air) being accelerated at line stretch. Finally, squidding, such

as that produced by drogue loads on the apex and rise/suspension loads on the canopy, elongate the canopy restricting the throat area of the parachute and resisting inflation, drawing it out and reducing the opening shock. Figure 22-13 shows the relationship of opening shock versus airspeed for a 28-foot canopy.

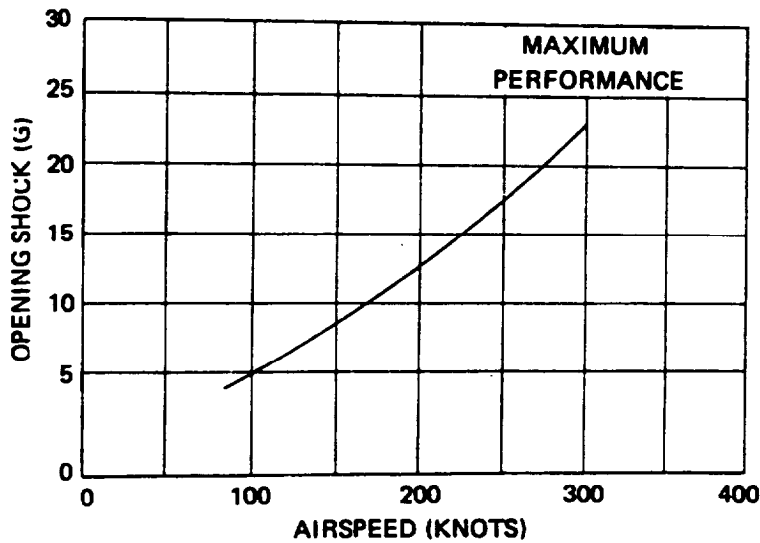

Figure 22-13. Parachute opening shock in relation to airspeed for a 28-foot-canopy.

High altitude seat-man separation is relatively rare with today's ejection systems. Almost all of our systems today are designed to initiate seat-man separation at about 12,000 feet \pm 2000 feet. However, when it does occur, additional hazardous factors are introduced. Terminal velocity increases at altitude, with the result that parachute opening shock is generally increased to a point where damage to the parachute structure or injury to the aircrewman may result. The higher altitudes (e.g., above 30,000 feet) also expose the individual to a low partial pressure of oxygen and low temperatures. The problem of an increased parachute opening shock is the most important of these factors. As altitude increases, air density decreases, and terminal velocity itself increases. Terminal velocity is dependent upon the aerodynamic drag of the falling body and aerodynamic drag is a function of air density. Therefore, at higher altitudes, the falling body falls at a faster rate to create an air drag equal to the weight of the body. Two other factors cause increased opening forces at higher altitudes. During parachute deployment, the drag created by the "streaming" chute is less; thus, a smaller deceleration force is applied. In addition, the increased rate of air flow and the reduced resistance to opening caused by low air density cause a more rapid deployment and inflation of the canopy. The overall effect is significant, and aircrew personnel

Emergency Escape from Aircraft

should be familiar with the consequences of high altitude parachute actuation. Figure 22-14 shows the relationship of altitude and parachute opening shock at the terminal velocity of an average weight aircrewman.

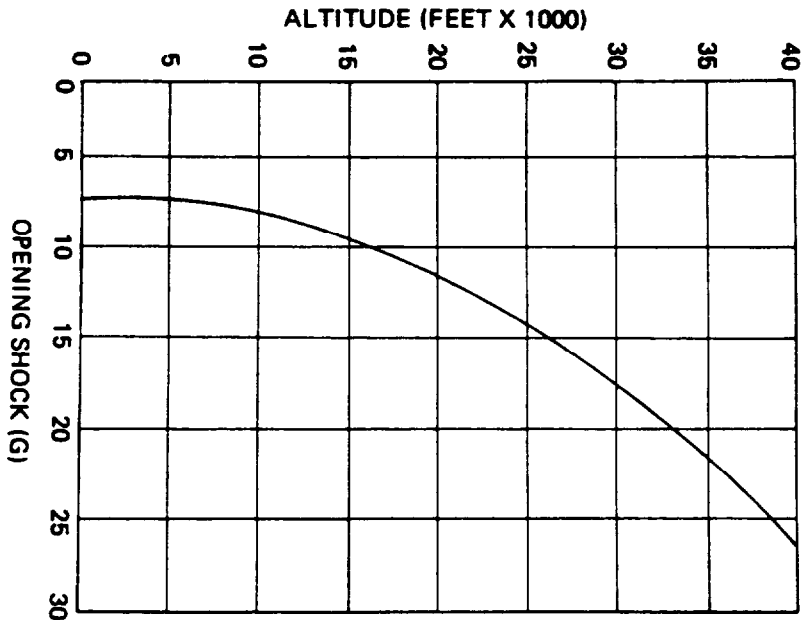

Figure 22-14. Parachute opening shock in relation to deployment altitude at terminal velocity of man (28-foot canopy).

In the past 20 years, there have been many improvements introduced to alleviate the problems we are going to briefly review. High-speed parachute opening tests (200-300 KEAS) were conducted years ago to determine parachute system integrity and the effects of acceleration and opening shock levels with regard to human injury (Dahnke, Palmer & Ewing, 1976). These results showed that high-speed parachute opening can produce catastrophic damage to the canopy. In addition to canopy damage, a number of other parachute system problems were encountered. The windblast integrity of all systems left much to be desired. This was evidenced by risers pulling out of the pack, excessive pack motion due to windblast, failure of the pack interface attachment to the survival kit, and risers being blown down over the shoulders.

High Altitude Problems

Problems of hypoxia during high altitude escape could only occur if, for some reason, the emergency oxygen supply in the escape system malfunctioned, or the oxygen mask was damaged or lost during escape. Problems with hypoxia are covered in Chapter 1, *Physiology of Flight*. Protective flight clothing is generally adequate to protect against frostbite at high altitudes. Use of gloves is especially important, however, since finger dexterity plays an important role during parachute descent and landing and postlanding survival activities. Disorientation and confusion may result from tumbling and spinning during freefall descent. The primary problem resulting from this tumbling and spinning is the increased likelihood of severe parachute entanglement during main chute deployment. These problems too, however, have all but been eliminated except for a few old systems that are still in use.

Vertical Descent Velocity

The vertical velocity at which the canopy lowers the aircrew member is essentially a function of parachute design configuration, fabric porosity, canopy size, and integrity. Generally, the larger the canopy diameter, the lower the landing velocity. Table 22-2 indicates the main performance requirements as found in MIL-P-85710. The rates of descent can be equated practically to the equivalent of jumping from heights of 3 to 10 1/2 feet onto solid ground depending on the particular parachute being discussed.

Parachute opening accelerations vary as a function of canopy diameter, but not in the way one would normally assume. Smaller canopies impart a greater G-loading during opening than do larger ones. The canopy, upon deployment, streams behind the aircrew member, creating a loss of momentum, and this affects the period of time to inflation. The smaller canopy reduces momentum to a lesser degree and inflates more rapidly than does a larger canopy of the same basic design. The differences in momentum reduction and filling time account for the greater acceleration of the smaller canopy.

Parachute Landing

The aircrew member performing an emergency parachute landing does not have the luxury of selecting the landing site, weather conditions, and the like. The landing may be in mountainous terrain where higher rates of descent and harder landings might be experienced, along with updrafts and downdrafts. They might be landing at night which precludes seeing landing hazards. In addition, they might be landing with high surface winds which impart a horizontal velocity during landing and might cause them to be dragged across the ground or water.

Emergency Escape from Aircraft

Table 22-2

Rate of Descent at Sea Level for Various Size Parachute Canopies and Man/Equipment Weights

Man/Equipment Weight	Canopy Size (Diameter) in Feet and Designation		
	24' Martin-Baker-- Rate of Descent	26' NB-6-- Rate of Descent	28' NB-7, 8, 9-- Rate of Descent
280 lbs	25 ft/sec	—	22 ft/sec
250 lbs	—	22 ft/sec	—
160 lbs	20 ft/sec	18.5 ft/sec	17.5 ft/sec

The proper prelanding position is mandatory if the chance of injury is to be minimized. Where altitude permits, the prelanding position should be assumed at an altitude of 1,000 feet above ground level. Both arms should be outstretched above the head with the hands firmly grasping the risers. The knees should be slightly bent and the feet held together (not crossed) with the toes pointed slightly down. The eyes should be directed at a 45-degree angle to the ground or on the horizon. This line of vision will help prevent anticipation of surface contact and the associated retraction of legs which becomes almost an involuntary act if looking straight down. Statistics concerning night landings indicate that the chances of injury are less than during daylight hours. One potential explanation is that the instant of landing impact cannot be readily anticipated, and therefore, less anticipatory leg tensing and retraction occurs.

Water landings present additional hazards. Drowning from dragging or parachute entanglement has been a serious problem and can happen to the best of swimmers even with relatively light surface winds. Since it is extremely difficult to judge height above water, no attempt should be made to release the parachute prior to landing. The aircrewmembers must release canopy fittings immediately upon entering the water or shed the entire harness assembly. The in-water entanglement problems proved especially severe during the Southeast Asia conflict where a large number of aircrewmembers came down over water or flooded rice paddies, either severely injured or unconscious (Every & Parker, 1976). The recent operational introduction of the FLU-8 which senses water entry and automatically inflates the life preserver has helped to reduce the number of drownings after ejection. The Parachute Harness Sensing Release Unit (PHSRU) more commonly referred to as SEAWARS (Sea Water Activated Release System) is another important develop-

ment that has reached the fleet. Shortly after salt water entry it automatically activates, separating the parachute canopy from the parachute risers. Both of these devices have proven their value as life saving equipment. Aircrews must still be taught and reminded that these are backup systems, and they must be ready to inflate their life preserver and release the parachute manually. They must also be warned that the PHSRU does not work in fresh water and may not work in brackish water such as river mouths or coastal marshes.

Ejection Mishap Summaries

Navy noncombat ejection survival percentages for a period of years, presented in Figure 22-15, shows a continuing rate of survival (nonfatal) of 78 percent or better for this period. The extent of injuries encountered during the last five years in these ejections is shown in Figure 22-16. The causal factors reportedly responsible for the fatalities over this period are presented in Figure 22-17.

Low altitude, low speed, and out of the envelope ejections are responsible for many fatal and major injuries in noncombat ejections. During combat ejections, almost 60 percent of major injuries are sustained during high-speed ejection. A comparison of nonfatal escape injuries for those two groups is presented in Table 22-3. The probable primary causes of known combat escape injuries are shown in Table 22-4.

The Emergency Escape Summary published yearly by the Naval Safety Center provides information on the latest mishap and injury trends for all Naval aircraft, not just ejection seat equipped aircraft. It must be pointed out that not all safety professionals agree with the cause and effect relationships discussed here. This is even more reason why a flight surgeon must seek help of other professionals when he/she is involved in a mishap investigation.

Pattern of Ejection Injuries

Preceding sections discussed reported injury causation as related to specific events associated with leaving a disabled aircraft both in combat and noncombat circumstances. The pattern of injuries likely to be produced by ejection is somewhat unique and should be recognized as such by the examining flight surgeon. There are certain injuries which could well be overlooked if the examiner was not sensitive to the circumstances of ejection and the particular forces that are applied to the aircrew member. Table 22-5 is presented as an overview of reported injury patterns which may result from ejection and summarizes the events producing these injuries. It should be of some value to a flight surgeon when developing a set of procedures to be used when a recovered aviator is examined.

EJECTION SURVIVAL PERCENTAGES

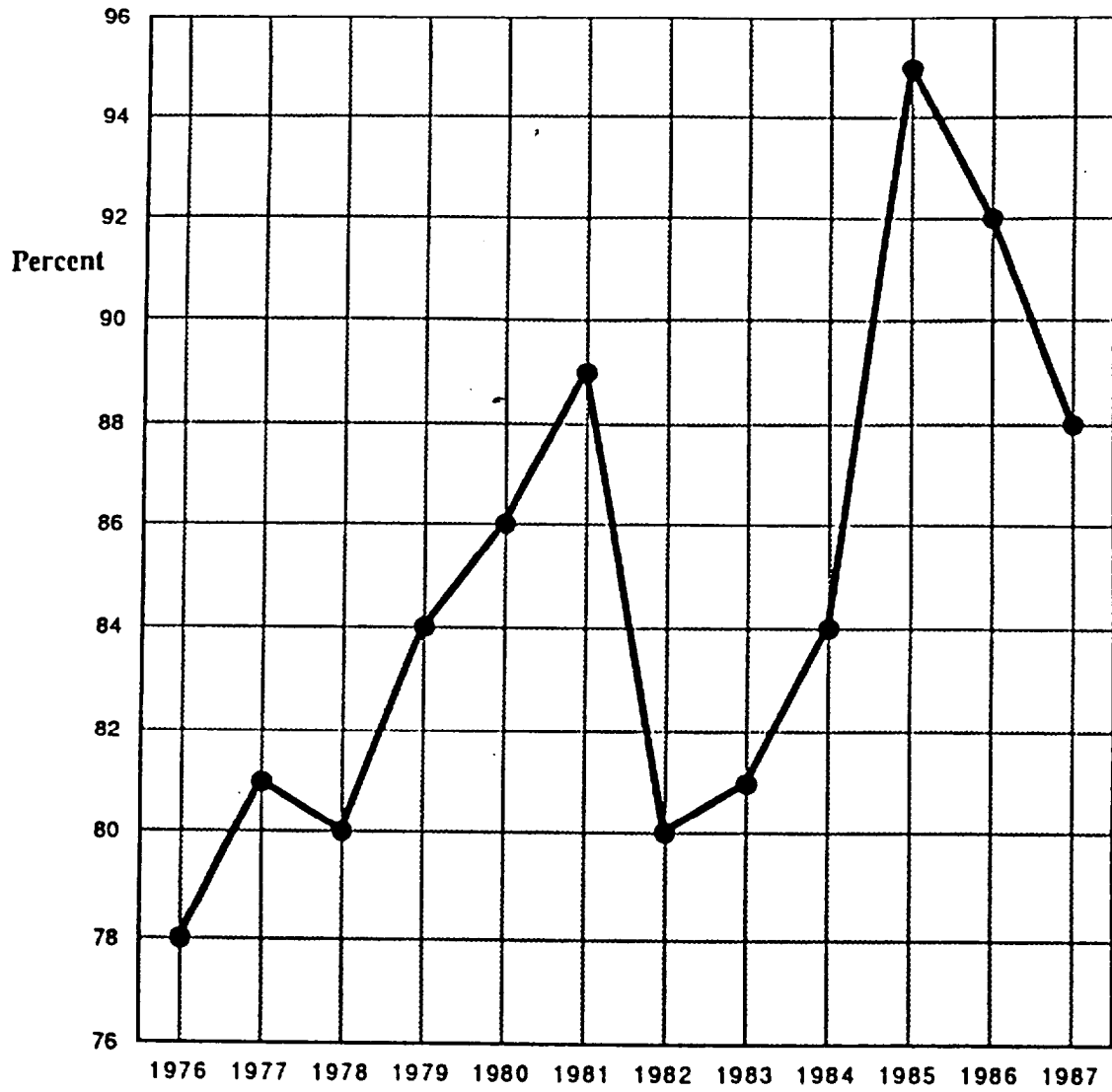

Figure 22-15. CALENDAR YEAR 1987 Naval Safety Center Emergency Airborne Escape Summary (noncombat data only).

U.S. Naval Flight Surgeon's Manual

Table 22-3

Non-Fatal Escape Comparison for Period During Southeast Asia Conflict (1966-1972)

	Injury		
	Major	Minor	None
Navy Combat	40%	30%	30%
Navy Non-Combat	19%	37%	44%

(From combat data, Every & Parker, 1977)

Table 22-4

Probable Cause of Known Combat Injury

	Percent
Flail	33
Enemy Inflicted	17
Ejection Seat G-Forces	14
Struck Object	13
Parachute Landing	11
Fire	10
Parachute-Opening Shock	2

(Every & Parker, 1976)

EJECTION INJURIES

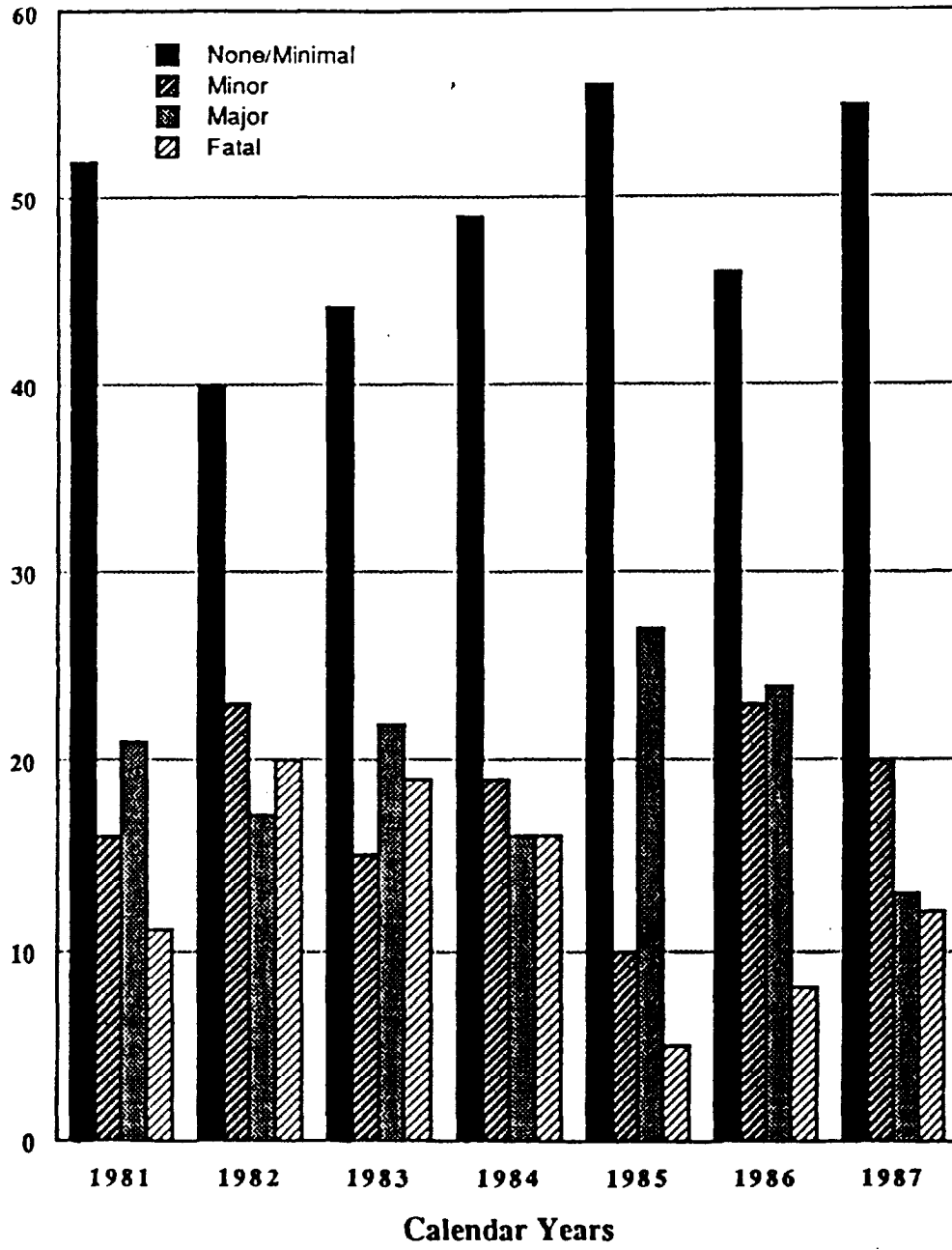

Figure 22-16. Naval Safety Center Emergency Airborne Escape Summary (1987).

EJECTION FATALITIES BY CAUSAL FACTORS CALENDAR YEARS 1982 thru 1987

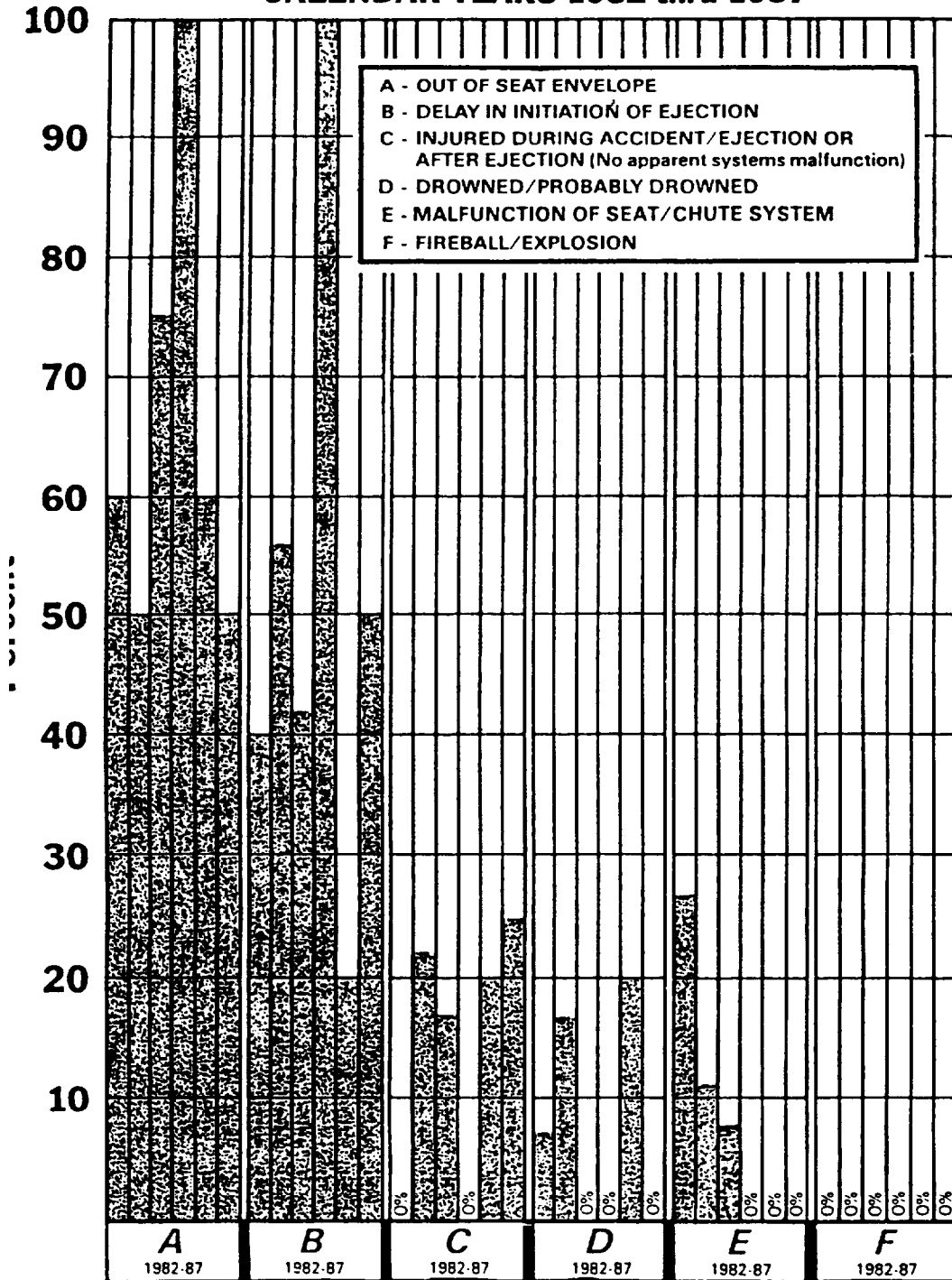

Figure 22-17. CAUSAL FACTORS* *Note: More than one factor may apply (i.e. if aircrew delayed ejection until out of envelope, fatality is counted in both factors).

Table 22-5

Overview of Ejection Injuries

Time	Cause	Injury	Comment
Pre ejection*	Fire in cockpit	Burns and smoke inhalation. Blindness.	Possible severe burn to exposed areas, especially if sleeves rolled up and gloves not worn.
	Explosion	Wide range from lacerations to multiple extreme.	Most commonly found during combat, however, may be caused by internal explosions or premature detonation of ordinance.
	Negative G	Head or neck strain. Cervical fracture.	Pushed up against cockpit from Negative G.
Ejection	Ejection seat G forces	Spinal compression fracture.	Most vulnerable area of the spinal column is from T-10 to L-2. Primary cause is out of proper ejection position, other contributing factors poor design of seat, type initiator charge, and space between seat and buttocks. Post-ejection physical should include radiological exam of entire spinal column.
	Struck by seat or cockpit object	Extremity fractures and/or lacerations. Foot fractures, especially toes.	Fracture of femur from leg being raised off seat during ejection. Striking cockpit or seat structure. RIO's and RAN's striking electronics equipment.
	Impact canopy structures	Severe lacerations. Neck strains. Spinal compression fractures. Hematomas.	Especially prevalent in thru-the-canopy ejections. Particularly A-6 and A-7 A/C. Contusion and hematoma injuries from striking canopy support structure parts.
	(a) Windblast	Petechial, conjunctival, and retinal hemorrhages.	Direct effect of windblast to exposed area.
	(b) Helmet rotation	Neck strain.	High-speed wind effect under helmet possibly can produce severe stress to neck muscles and cervical vertebrae area.
	(c) Hail and rain	Contusions. Hemorrhages.	Rain and hailstones will cause severe injury to unprotected parts of the body at speeds in excess of 400-450 knots.

*In Vietnam combat, 20 percent of the major injuries received by aviators occurred prior to ejection.

Table 22-5

(Continued) Overview of Ejection Injuries

Time	Cause	Injury	Comment
Ejection (Continued)	Flail (linear deceleration)	Fractures. Dislocations of upper extremities, predominately to elbow, upper arm, and shoulder area. Torn ligaments and dislocation of lower extremities, predominately to knee area. Fractures to tibia and fibula. Cervical strain.	Most common of the major high-speed escape injuries. Results from Q-forces producing differential deceleration of the extremity relative to the torso and seat. Followed by a sudden striking of seat structure or reaching the limit of the joint. Less prevalent on seats with extremity restraint system.
	Accelerative and decelerative forces	(a) Internal injuries to body tissues and organs. (b) Unconsciousness.	The multiple shock like forces which act on the aircrewman during ejection can produce tearing and rupture injuries to thoracic and abdominal organs. Of special criticality are cardiac injuries, consequently a cardiologic exam should be included in all post ejection physical examinations. High percentage of unconsciousness during ejection due to a specific impact or a summation of forces. Some cases lasting several hours.
Parachute Deployment	Parachute opening shock	Cervical fracture or strain. Contusions or severe muscle sprains to torso. Dislocation of cervical vertebrae. Fracture thyroid cartilage.	These injuries are intensified by a loose torso harness, premature parachute opening, and possibly the use of devices to aid in parachute deployment or canopy inflation. Dislocation of cervical vertebrae may be linked with loose chin strap.
	Riser slap	Facial fractures, contusions, or lacerations.	Usually from excessive yaw or uneven tension on parachute risers during canopy inflation, If part of riser harness catches on the helmet possible cervical fracture could result.

Table 22-5

(Continued) Overview of Ejection Injuries

Time	cause	Injury	Comment
Parachute Descent	High altitude ejection	Frostbite.	Severe frostbite possible to exposed skin following high-altitude ejection or very cold climates.
	High-speed rotation and/or spinning Descent thru trees	Severe pain. Hemorrhages. Displacement of limbs. Lacerations.	Generally only a problem if stabilizing system on ejection seat fails or at very high altitude. Parachute descent thru trees can result in severe contusions and lacerations from the trees. Parachute damage may also result in severe landing injuries.
Landing	Landing impact	(a) Leg-ankle fracture. (b) Spinal fracture.	Results from improper landing especially on hard or rough terrain. Likelihood of this type injury is increased with parachute oscillations during landing. Existing fractures may become comminuted at this time. Usually occurs to lower thoracic, lumbar, or coccyx as a result of sit down landings.
	Parachute drag	Severe drag burns. Fractures.	Severity depends on wind, terrain, and time before parachute release.
	Descent in or near fire-ball In-water parachute entanglement	Burns. Water in lungs and stomach.	The frequency of this mishap is greatly increased in escapes from V/STOL aircraft. Quantities of water can be ingested into the lungs or stomach following parachute landing and entanglement in open water.
General	Escape event	Shock.	An aircraft ejection, even under the best of conditions, is extremely taxing physically as well as mentally. The Flight Surgeon should watch carefully for signs of shock, even in what appears to be an injury free escape.

22-41

Emergency Escape from Aircraft

Special Escape Problems

Previous discussion has centered about ejection from fixed wing jet aircraft. Additional problems are encountered with escape from fixed wing nonejection seat equipped aircraft, rotary wing aircraft, vertical/short takeoff and landing (V/STOL) aircraft, and in crash landings, ditchings, and underwater escape.

Rotary Winged Aircraft

Helicopters have unique problems of escape. In general, should engine failure occur above a minimum altitude (usually around 400 feet), there is less danger because the pilot can usually initiate autorotation and make a safe descent. If, on the other hand, engine failure occurs below a maximum altitude (usually 30-40 feet), the helicopter may be able to absorb the crash energy through the structure of the aircraft. The primary threat in this case is fire upon impact. For helicopters that lose power, the most dangerous altitude therefore, is roughly below 400 feet and above 40 feet. Within this altitude zone, engine failure can result in severe impact injury or death to the occupants.

Parachutes which can be worn or carried aboard helicopters have not proven to be practical and their use has been minimal due to the low altitude at which escape situations usually occur (below minimum parachute recovery altitude), and the danger of impacting main rotor blades after egress. There have been a number of successful bailouts from helicopters, and Table 22-6 shows the limited number of parachute attempts from helicopters over a thirty year period.

Table 22-6

Cumulative Bailouts by Selected Type Helicopters 1953 thru 1988

Aircraft	Total	Survival	Fatal
AH-1	1	1	
UH-2	2	1	1
SH-3	4	4	
UH-25	1	1	
CH-53	2		2
OH-58	1		1

V/STOL Aircraft

Vertical takeoff and landing aircraft such as the AV-8 Harrier have the unique problem of requiring an escape system which will perform at conventional high speeds and high altitudes as well as at low altitudes with zero horizontal velocity. Early ejection experience with this type aircraft showed that most ejections occurred at low speeds and low altitudes with the aircraft sinking and/or banked (Reader, 1973). Two specific problems were critical with this early type of ejection: (1) Ejection was below the low altitude limit of the envelope and sometimes prevented full parachute deployment before impact; (2) the pilot ejected and descended into the aircraft's wreckage or fireball. However, the current ejection seats in V/STOL type aircraft have demonstrated success rates that are equal to or better than ejection seats in other aircraft.

Underwater Escape

Underwater ejection has not been common in naval aviation. With the zero-zero seat, the occurrence has declined. However, the Navy has had a number of successful underwater ejections. This method of escape is mentioned here because naval operations from aircraft carriers present it as a constant possibility. Manual escape with the help of the life preserver is always preferred to ejection if the aircraft canopy is open or off when submersion occurs. The introduction of the FLU-8 and PHSRU (SEAWARS) units discussed earlier further complicate this type of egress since they are water activated. Aircraft oxygen would be available until after ejection when the seat pan oxygen is activated. The life preserver should be inflated once clear of the aircraft even though the FLU-8 will most likely do this automatically. While ascending to the surface, the survivor should exhale constantly to avoid an aeroembolism.

The most critical problem involving helicopters underwater escape is the inability of aircrew members and passengers to escape from the aircraft following submersion. Submersion accounts, by far, for the greatest loss of life from this type of aircraft mishap. Data from the Naval Safety Center show that over a five-year period (CY 1979 - 1983) 65 helicopters landed or crashed into the water resulting in 70 fatalities. A large percentage of these losses were attributed to drownings, entrapment in the submerged aircraft, or lost at sea. Descriptions of survivors' escapes verify that in many cases it was only luck that saved them. Panic, disorientation, jammed hatches, entanglement, in-rushing water, and darkness are words common to almost every crash scenario of a helicopter in the water.

Until recently, the lack of any real flotation capability for most Navy helicopters undoubtedly affected the survivability of in-water helicopter crashes. Table 22-7 presents the survival rates for six types of helicopters now in use by Navy and Marine Corps forces. The survival rate at night is

far less than the day rate. It may be presumed that the darkness of night adds to the confusion and disorientation of the crew and passengers leading to their entrapment while the aircraft is sinking.

Table 22-7

Helicopter Water Escape Cumulative 1982-1986

Type	Total Mishaps		Total Occupants		Total Fatalities		Survival Rate	
	Day	Night	Day	Night	Day	Night	Day	Night
AH-1	1	1	2	2	2	1	0%	50%
UH-1	4	1	17	3	-	3	100%	0%
H-2	8	8	32	28	1	9	97%	68%
H-3	8	8	35	34	-	1	100%	97%
H-46	8	3	52	25	14	19	73%	24%
H-53	6	-	44	-	30	-	32%	-
H-57	-	-	-	-	-	-	-	-
H-60	2	1	7	3	2	-	71%	100%
Totals	37	22	189	95	49	33	74%	65%

(From Naval Safety Center 1987 Emergency Airborne Escape Summary)

A number of ways are currently being explored to enhance the survivability rates of helicopter in-water crashes. These include improving helicopter crashworthiness, installing aircraft emergency flotation systems, using pyrotechnics to create emergency hatches, providing better emergency lighting of existing hatches, supplying emergency underwater breathing systems, and improved water survival training and equipment.

Crashworthiness

A crash deceleration usually produces a combination of positive Gz (eyeballs-down) and positive transverse Gx (eyeballs-out) because the velocity along the flightpath typically has a horizontal and a vertical component. Figure 22-18 shows the terminology used for describing the decelerative forces.

Emergency Escape from Aircraft

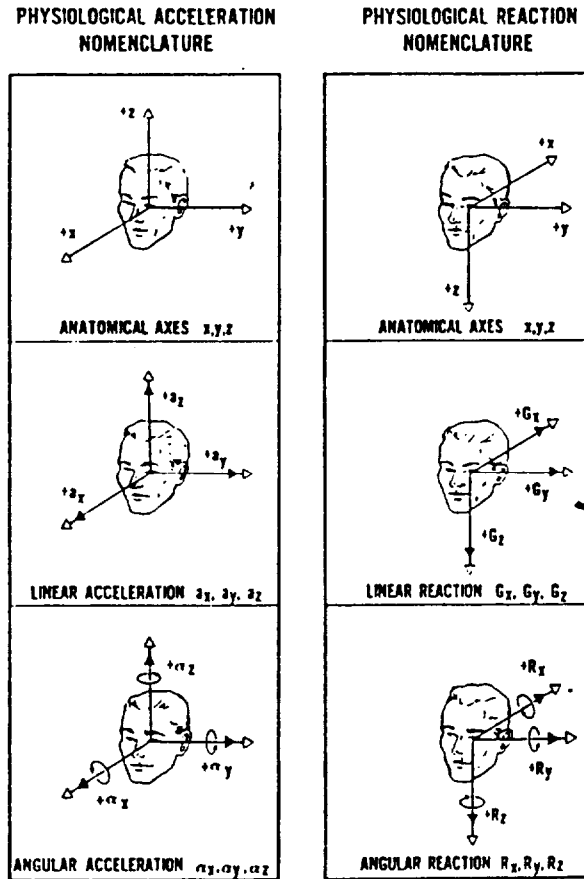

Figure 22-18. Accelerative forces on the body.

The term crashworthiness refers, in general, to the capability of an aircraft and its subsystems such as seats, restrains, landing gear, etc. to protect its occupants during and after a crash. The amount of protection that is afforded by the aircraft will depend greatly upon the amount of thought that went into crash survivability during its original design. Improvements to crashworthiness through later retrofit and update programs, although important, usually can only achieve limited success since a systems approach cannot be taken to the entire problem of crash survival. This approach is to consider and design for the positive interaction of all elements that will aid in the occupant's survival. It starts with the design of the aircraft structure, giving it the capability to absorb energy through controlled deformation. A sturdy, smooth understructure will prevent abrupt deceleration as a result of the "plowing" effect in low angle type impacts on soft terrain.

Inclusion of energy attenuating landing struts will help to dissipate some of the ground impact forces before it can reach the inhabited areas of the aircraft. The effect of water impact has not been recently studied. Most safety engineers believe that water impact is more serious due to the hydrodynamic effects. Within these areas, the ground impact forces transmitted to the occupants through their seats and restraint systems must be managed so as not to exceed the limits of human tolerance. This can be done by providing energy attenuating seats with sufficient clearance to displace downward toward the floor. Delethalizing the structures in the occupant's immediate vicinity and keeping those structures substantially intact to the extent that a livable volume is provided throughout the crash sequence, is another important aspect of a total system design. Postcrash fire retardation or elimination, breathing aids for underwater evacuation, emergency egress lighting, and personal, as well as, aircraft flotation will ensure that the occupants can evacuate the aircraft after surviving the crash. Lastly, the crew and passengers must be given the means to survive in a harsh environment outside of the aircraft until rescued. This includes the need for protective clothing appropriate for the environment, survival gear, signaling devices, and aviation life support equipment such as rafts and emergency medical supplies.

As of 1988 operational subsystems to improve crashworthiness were being utilized or were being developed for the H-46, H-53, H-3, UN-IN, and AH-1 helicopters. In most cases, energy attenuating (EA) pilot and copilot seats are replacing older noncrashworthy seats. The H-46 and H-53 helicopters have undergone a Service Life Extension Program (SLEP) which included providing energy attenuating armored crew seats and crashworthy fuel cells to eliminate post crash fire. Currently, Helicopter Emergency Egress Lighting (HEEL) and Helicopter Emergency Flotation (HEF) subsystems have completed their final stages of development in anticipation that they will be retrofitted into those aircraft. HEEL has also been developed for the SH-60B, H-2, and H-3 helicopters.

The SH-60B Sea Hawk, one of the latest Navy helicopter types to join the fleet, has come closest to applying a total systems concept to crash survival. Crashworthiness was an important part of the aircraft design and the benefits derived from this forethought have resulted in the survival of crew members in severe crashes that would have been otherwise nonsurvivable. The Sea Hawk has energy attenuating landing struts; a box type subfloor structure than can maintain its integrity during a potentially survivable crash; impact resistant fuel cells to reduce the possibility of fire; inflatable exterior fuselage flotation bags; and energy

Energy Absorbing (EA) Seats

A major improvement to helicopter crashworthiness came through the introduction of energy absorbing (EA) seats. Most Navy helicopters now either have or are in the process of being

Emergency Escape from Aircraft

retrofitted with EA pilot, copilot, and some crew member's helicopter seats. Future helicopters will be required to provide these seats for the protection of all personnel carried aboard the aircraft.

The principle of operation is to support the seat bucket by a load limiting device that will allow the bucket and occupant to move toward the floor of the aircraft when the limit load of the EA is reached (Desjardins and Laananen, 1980). By selecting a proper level at which seat energy attenuation begins, the stroking seat simply lengthens the stopping distance of the occupant by allowing the seat stroking to occur during a crash as the deformation of earth, landing gear, and the crushing fuselage structure are nearing completion. As long as the seat is stroking, the acceleration on the occupant will be maintained at a relatively constant level until the kinetic energy of the seat has been exhausted. If there is not sufficient space for the seat to stroke fully, it will "bottom-out" against the floor producing a much higher acceleration on the occupant which may result in injury. It is, therefore, important that there is sufficient, "clear space" between the bucket and the structure surrounding it. In the SH-60B, a depression has been designed into the floor directly under the bucket to provide additional space for it when displacing downward. *Equipment, such as first-aid kits, tool boxes, helmet, etc., must never be stored under these seats because it would impede the bucket movement and negate the EA capabilities of the seat!* The flight surgeon must play a critical role here in educating fleet aircrew on these systems. The design and development of effective EA troop seats has lagged behind the development of cockpit seats. Currently the H-46, H-53, and H-3 use conventional noncrashworthy stowable seats in their aft compartments. These seats do not possess the structural integrity to withstand a crash load exceeding -2 Gz on a 95th percentile occupant. However, EA troop seats currently in development may be retrofittable to these aircraft.

Training

Navy policy presently does not require aviation personnel to perform actual parachute jumps. Aircrew personnel are required, however, to undergo training in order to learn the proper techniques and procedures for dealing with emergency situations.

Emergency Ground Egress

Ditching and emergency ground egress drills are required by the Chief of Naval Operations (CNO). Even with high performance aircraft equipped with zero-zero ejection seats, there are takeoff and landing emergencies on the deck which require split second decisions as to whether to eject or stay with the aircraft. Historical, survival rates for on deck emergencies were very similar for both those who ejected and those who chose to remain with the aircraft (Rice & Ninow, 1971). This trend has changed in recent years, however.

As a consequence of perception about impact survivability, weight budgets, and concern for the safety of nonaircrew personnel, transport, patrol, and helicopter aircraft have not been provided with ejection seats. Accordingly helicopters, patrol, antisubmarine warfare ASW, and transport aircraft offer a higher probability of on-the-ground egress following an airborne emergency. Studies of military and commercial aircraft mishaps (Pollard & Klotz, 1971), reveal that most fatalities are not due to crash trauma but to the inability to get out of the aircraft. These studies were made using data from fixed wing aircraft. However, since helicopter airframes are generally less substantial, it is expected that structural damage to hatches would be even greater following helicopter impact.

Drills stress utilization of both primary and secondary escape hatches. It is recommended that drills be initiated either immediately after crew members have embarked and are strapped in, or immediately following aircraft engine shutdown. Crews are scored on the basis of following correct procedures and exiting the aircraft within a prescribed time. Regularly scheduled drills will correct faulty procedures and considerably shorten the time required to abandon the aircraft. Records are normally maintained by the squadron safety officer to ensure that drills are held periodically, and that exit time is within the allotted limit. The squadron safety officer should review NATOPS for all aircraft in the squadron to determine egress times with or without auxiliary equipment which might block a specific egress path. Lectures on egress should include complications due to fire, smoke, injury, panic, jammed hatches, etc. These drills are most effective when no forewarning has been given to the crew members. At some activities, the squadron safety officer or his/her representative will meet an arriving aircraft and give a prearranged signal to the pilot who in turn will announce "emergency egress" or "ditching drill" to the crew. The total elapsed time is then recorded, and errors in procedures noted. This permits immediate discussion of problem areas and also serves as an indication of errors to all crews. Flight surgeons must be involved in this training as much as possible. Times could even be analyzed, trends established, and improvements could be recommended.

Dilbert Dunker and Helicopter Escape Trainer

The Dilbert Dunker consists of a simulated aircraft cockpit section mounted on rails which extend into a swimming pool. The trainee, after receiving proper indoctrination, is seated in the cockpit with shoulder harness and lap belt secured. The cockpit assembly is released and slides into the water, and the forward section (nose) is rotated down until the cockpit is inverted and completely immersed. After all motion stops, the trainee releases the restraints, exits the cockpit, and surfaces. As a safety precaution, specially trained scuba-equipped swimmers are located in close proximity to observe the actions of the trainee and lend assistance if necessary. A training program also exists for the Helicopter Emergency Egress Device (HEED).

Emergency Escape from Aircraft

The Naval Training System Center (NTSC Orlando, FL) has developed a Multistationed Underwater Egress Trainer which can be flooded, permitting practice escapes from a submerging helicopter, patrol ASW, or transport aircraft. A number of these devices have been distributed to various Navy and Marine Corps activities.

Parachute Harness Release Training

Two devices are used to demonstrate problems associated with parachute harness release. One device, the Para-Drag, allows students to experience problems in releasing parachute harness fittings under conditions simulating those which would be found when an aviator is dragged across the surface of the water by the parachute canopy. The other is known as the Parachute Disentanglement Trainer. With this device, the student can experience problems with shroud line entanglement, and become acquainted with the difficulties involved in locating and operating the seat pan release mechanism during parachute descent.

Helicopter Hoist

In this exercise, each type of hoisting apparatus currently in operational use is placed in the water where the trainee demonstrates the ability to board or enter each device properly and is then hoisted vertically just clear of the water. Many squadrons use "live" helicopter hoisting as a means of training. Arrangements are made with a helicopter squadron or unit to perform actual hoists from an offshore location or from a nearby bay or lake. This permits indoctrination in boarding both the rescue device and the rescue craft while in the actual downwash created by the helicopter rotor blades. It also provides excellent training for the helicopter crews.

Ejection Seat Training

In addition to the above, aircrew members of ejection seat equipped aircraft receive training in the proper procedures for use of the ejection seat in their aircraft. Training is centered on the aeromedical aspects of ejection rather than when to eject, or how the system works.

Procedure Trainer. Procedure trainers are available for many high performance aircraft. These are static devices which duplicate the specific seat installed in a particular aircraft and, in some cases, a portion of the cockpit itself. Some operational flight trainers (OFTs) could be used as ejection procedure trainers if so modified.

The procedure trainer provides indoctrination in the sequence of activities necessary for successful ejection: body position, actuation sequence, secondary methods of actuation, etc. In addition, ground emergency escape (nonejection) procedures can be practiced.

U.S. Naval Flight Surgeon's Manual

Static Seat. While afloat or when stationed at a place which does not have a procedure trainer, a deactivated ejection seat may be used as a training device. Extreme care must be taken to ensure that the seat has been made safe. All cartridges, both propulsion and gas initiator, must be removed and should be actually sighted by personnel prior to sitting in the seat or actuating seat controls. This is best accomplished during required periodic inspection of the aircraft and seat, when it will not interfere with aircraft utilization, or by using seats that have been recovered from a mishap and have been checked and verified to be safe.

Ejection Trainer. The Universal Ejection Seat Trainer Device 9E6 utilizes a choice of ejection seats, a pneumatic charge, and a set of rails which project upward and backward at an angle of 18 degrees from the vertical. Prior to ejection, the height and weight of the aviator are taken, the seat is adjusted for that height, and the pneumatic charge setting is adjusted for that specific weight. This variable charge helps to ensure that the aviator is subjected to no more than 4 to 5 G's during the training.

The aircrew member assumes the recommended body position. Upon actuation of the face curtain, or lower ejection handle the pneumatic charge propels the seat and occupant up the guide rails approximately 6 to 7 feet. A means is provided for lowering the occupied seat back down to ground level. This type of training has proved to be extremely effective, if closely monitored and used to enforce and reinforce correct usage and operation of the system. Aircrew members who have made emergency ejections indicate that the dynamic training prepared them for the actual emergency condition and aided in relieving apprehension concerning catapult firing. The vast majority of these training devices are available at the Aviation Physiology Training Units scattered throughout the fleet.

For more information concerning aviation escape and survival training, consult a U.S. Navy Aerospace Physiologist.

Future Escape and Survival Systems

Ejection Seats

The performance characteristics and reliability of existing seats are continually being updated to match the increased performance of new aircraft. Work is proceeding toward the development of a seat mounted electronic sequencer and controller which will eliminate the two, three and four mode sequencing systems presently being used to control ejection events. The heart of this new system is a microprocessor which expands timing selectivity and decision making capabilities to optimize seat performance under all ejection circumstances. Initial flight reference information

Emergency Escape from Aircraft

obtained from the aircraft data bus such as altitude, attitude, angular rates and speed, in addition to seat mounted sensors, can be rapidly processed to select the best combination of ejection events that will lead to the aircrew member's safe recovery. The microprocessor will also be able to process inflight information and through a controller tilt the seat aftward in the cockpit to increase the aircrew member's tolerance to high G maneuvers.

Seat stabilization is another area that is being given emphasis. It is important to maintain the seat and occupant in a stable forward facing position during ejection for orderly parachute deployment and to prevent high lateral ($\pm G_y$) accelerations that can cause injury. Yaw fin stabilizers have been demonstrated to effectively stabilize the seat in this position. Normally positioned against the sides of the seat, these small fins are automatically deployed and locked into position as the seat moves up the guide rails. Other seat stabilization systems such as afterbodies, inflatables, drogues, and bridles are also being studied.

Parachutes are also continually in the process of improvement. Development is proceeding on variable porosity materials to reduce the magnitude of high speed canopy opening shock forces. Steerable and glideable configurations are being developed to help the crew member select a safe landing area. Other areas being investigated are service life extension, vacuum packaging, deployment, and stability improvements.

Lack of adequate windblast protection has been a major deficiency of open ejection seats. Ejection experience indicates that limb flailing injuries usually occur at speeds above 300 KEAS. Therefore, new types of passive upper body and arm restraints are being developed to contain the limbs so that aerodynamic loads do not force them outward and backward where they are arrested either by the seat structure or the body joints limit of articulation. A "one size fits all" seat mounted restraint/harness has shown that it has the potential to solve this problem and to meet the other requirements of an acceptable restraint. These characteristics are comfort, ease of donning, in-cockpit maneuverability, use as a parachute harness, and rapid divestment. Development of this system is ongoing.

Future supersonic aircraft may, of necessity, move more and more to the escape module concept. At this time, the baseline crew module continues to be the F-111. Although this module permits a "shirtsleeve" environment for the two crew members and solves many problems associated with the open ejection seat, it has a number of deficiencies. The comparatively long time it takes to inflate the parachute coupled with its weight and cost penalties has discouraged this application to other aircraft designs. However, operational scenarios that include flights at high altitudes in excess of 60,000 feet and high speeds resulting in a Q-force in excess of 1600 lbs. may require a reexamination of capsules. New technology breakthroughs in light weight composites,

microprocessor control, rapid opening and load limiting parachutes, and energy absorbing techniques have opened new design pathways for resolving many of the problems that have discouraged the development of capsules for the last generation of fighter and attack aircraft.

Helicopter Survivability

Advances are also being made in increasing the performance efficiency and effectiveness of present day EA seats. A variable load EA has been developed that is optimally adjustable for any occupant weight. Currently, the load of an EA is set to the weight of a 50th percentile aircrew member and will stroke the seat when:

Load = (bucket weight + 50 percent occupant weight) x 14.5 G. This means that the 5th or 95th percentile aircrew member in a nonadjustable EA seat will be exposed to higher or lower G's. To set the variable load EA, the occupant simply adjusts a dial on the seat to his or her dressed weight. This action automatically seats the EA to stroke at 14.5 G by adjusting its load producing mechanism. An automatic version of the variable load EA is being developed which will adjust the EA load with no manual input required, thus reducing the risk of improper settings.

It is extremely important that the crew member be tightly restrained in the seat during a crash to prevent "dynamic overshoot" or "submarining." An Inflatable Body and Head Restraint System (IBAHRS) is being developed to automatically and effectively take up any slack in the upper restraint. This is accomplished by sensing the crash and rapidly inflating bladders which are an integral part of the left and right shoulder straps. The inflating bladders expand against the crew member's chest, filling and removing strap slack. Within one second of the crash, the bladders are deflated as the gas is cooled and escapes from the semiporous bag material.

Helicopter flotation is urgently needed because of the number of drownings and entrapments in submerged helicopters. As previously mentioned, in an attempt to reduce losses of this type, a Helicopter Emergency Flotation System (HEFS) has been developed for the H-46 but modifications of the design are applicable to other aircraft. The system uses two flotation bags, one attached to each side of the aircraft. When deflated, they are stowed with an automatic inflation device in a removable pod. The Kevlar bags, each containing 140 cubic feet of volume, are inflated by a carbon dioxide gas generator that can compensate for outside temperatures extremes and fill the bags to the same pressure regardless of temperature conditions. Each bag will float 8,960 pounds. A series of developmental tests have demonstrated that HEFS can keep an H-46 afloat in an upright position for more than 10 minutes. Based upon trials and mishap records, this should prove to be sufficient time for all the occupants to evacuate the helicopter before it submerges.

Emergency Escape from Aircraft

Each of the above technological improvements will help to increase helicopter personnel survivability. However, it should be emphasized that the major life saving payoff will only be realized when a true systems approach is taken to improve survival potential in an aviation mishap. Your findings and recommendations are critical from this point of view.

Land and Sea Survival

Because of the success of peacetime search and rescue operations in effectively locating and rescuing downed aircrewmembers, survival kits are designed for short duration (24-hour) survival. Survival during combat operations, however, might involve relatively long periods of escape and evasion and require extensive first-aid knowledge and special equipment. If captured, self-administered first-aid may prove to be the only medical attention the survivor will receive during his time as a prisoner of war. Consequently, training in combat and survival first aid must be constantly upgraded and reviewed to insure proper and effective self-administration under high-stress conditions.

Also, as previously mentioned, the number of fatalities occurring because of in-water parachute entanglement are being described through the recent fleet introduction of the Parachute Harness Sensing Release Unit and the FLU-8 automatic life preserver inflator. As part of the risers, PHSRU automatically separates the risers from the man upon sensing water entry. The complimentary system known as the FLU-8 also contains an independent water sensing switch which upon water entry automatically initiates a CO₂ cartridge cylinder which inflates the life preserver. Both of these systems have been deployed to the fleet and have already saved lives. These systems are noteworthy for the protection that they provide to the disabled and unconscious aircrew member landing in the water.

The dangers of cold weather exposure are being lessened by the improvement of antiexposure garments and using materials such as polytetrafluoroethylene, (PTFE) cloth better known by its commercial name GORTEX. These suits now provide better cold weather protection and are more acceptable and comfortable to the wearer. A quick donning antiexposure garment that provides full protection against environmental threats is being developed for long flight mission aircraft where emergency landings might involve a long period before rescue.

In-water survival will be improved by the hooded miniraft which can be vacuum packaged into a compact volume easily stowed on the seat or carried by the crew member. Escape from a submerged or smoke filled fuselage will be made easier by the Helicopter Emergency Egress Device (HEED). HEED gives the crew member a source of breathable air to help during aircraft evacuation. These and other technologies are being developed to keep abreast of new and

changing environments and weapons that threaten aircrew survivability. Faster speeds and higher accelerations, nap of the earth flying, vertical takeoffs and landings, etc. have taxed and challenged the engineer's and scientist's ability to conceive and develop aviation life support equipment that protects the aircrew member when an emergency arises. Other threats which use laser, nuclear, chemical, and biological weapons technology also are influencing the future direction of escape and survival systems.

References

- Dahnke, J.W., Palmer, J.F., & Ewing, C.L. Results of parachute-opening forces test program. Final Report, National Parachute Test Range, El Centro, CA, April 1976.
- Department of the Navy, Office of the Chief of Naval Operations and Naval Air Systems Command. NATOPS Flight Manuals for S-3, A-7, F-18, AV-8B and EA-6 Aircraft.
- Department of the Navy, Naval Safety Center. *United States Navy Emergency Escape Summary*. NAS, Norfolk: Naval Safety Center, Aeromedical Division, 1984, 1985.
- Desjardins, S.P., & Laananen, D.H. Aircraft crash survival design guide. Volume IV, USARTL-TR-79-22D, Prepared by Simula, Inc. under Contract DAAJ02-77-C-0021, Applied Technology Laboratory, Ft. Eustis. VA, June 1980.
- Every, M.G., & Parker, J.F., Jr. Biomedical aspects of aircraft escape and survival under combat conditions. Prepared by BioTechnology, Inc. under Contract N00014-14-72-C-0101, Office of Naval Research, Washington, DC, March 1976.
- Every, M.G., & Parker, J.F., Jr. A review of problems encountered in the recovery of Navy aircrewmembers under combat conditions. Prepared by BioTechnology, Inc. under Contract N00014-72-C-0101, Office of Naval Research, Washington, DC, June 1973.
- Every, M.G., & Parker, J.F., Jr. Aircraft escape and survival experiences of Navy prisoners of war. Prepared by BioTechnology, Inc., under Contract N00014-72-C-0101, Office of Naval Research, Washington, DC, August 1974.
- Every, M.G., & Parker, J.F., Jr. A summary of Navy air combat escape and survival. Prepared by BioTechnology, Inc., under Contract N00014-72-C-0101, Office of Naval Research, Washington, DC, February 1977.
- Glaister, D.H. The effects of acceleration of short duration. In Gillies, J.A. (Ed.). *A textbook of aviation physiology*. London: Pergamon, 1965.
- Jones, Patrick, J. A brief history of ejection seat development. *The Survival and Flight Equipment Association- Winter Journal*, 1974, 7.
- Kaplan, B.H. Method of determining spinal alignment and level of probable fracture during static evaluation of ejection seats. *Aerospace Medicine*, 1974, 45, 942.
- Kreffft, S. Cardiac injuries resulting from ejection. *Aerospace Medicine*, 1974, 45, 948-953.
- Latham, F. A study in body ballistics seat ejection. *Proceedings of the Royal Society*, 1957, Series B, 147, 127-139.
- Melzig, H.D., & Schmidt, U. Escape measures for combat helicopter crews. In Jones, W.L. (Ed.), *Escape problems and maneuvers in combat aircraft*. AGARD Conference Proceedings No. 134, Soesterberg, Netherlands, September 1973.

Emergency Escape from Aircraft

- Nuttall, J.B. Emergency escape from aircraft and spacecraft. In Randel, H.W. (Ed.), *Aerospace Medicine* (2nd ed.). Baltimore: Williams and Wilkins, 1971.
- Payne, P.R. On pushing back the frontiers of flail injury. Presented at the AGARD Aerospace Panel Specialist Meeting, Toronto, Canada, May 1975.
- Pollard, F.B., & Klotz, G.D. Method for improving helicopter crew and passenger survivability. Presented at the Ninth Annual SAFE Symposium, Las Vegas, NV, September 1971.
- Reader, D.C. Human factors aspects of in-flight escape from helicopters. In Jones, W.L. (Ed.), *Escape problems and manoeuvres in combat aircraft*. AGAR Conference Proceedings No. 134, Soesterbert, Netherlands, September 1973.
- Rice, E.V., & Greear, J.F., III. Underwater escape from helicopters. Presented at the 11th Annual SAFE Symposium, Phoenix, AZ, October 1973.
- Rice, E.V., & Ninow, E.H. A review of high performance aircraft takeoff and landing accidents. Presented at the Ninth Annual SAFE Symposium, Las Vegas, NV, September, 1971.
- Ring, S.W., Brinkley, J.W., & Noyes, F.R. USAF non-combat ejection experience 1968-1973. In *Incidence, distribution significance and mechanisms of flail injury*. AGARD Conference Proceedings No. 170, Toronto, Canada, May 1975.
- Rotondo, G. Spinal injury after ejection in jet pilots: mechanism, diagnosis, follow-up and prevention. *Aviation, Space and Environmental Medicine*, 1975, 46, 842.
- Stapp, J.P. Effects of mechanical force on living tissue. 1. Abrupt deceleration and windblast. *Journal of Aviation Medicine*, 1955, 26, 268-288.
- Walchner, O. Parachutists' spin problem. Unpublished report presented at the AGARD Aeromedical Panel Meeting, Copenhagen, Denmark, 1958.
- Walker, H.R., Jr. Operational practicality of fly away ejection seats. In W.L. Jones (Ed.), *Escape problems and manoeuvres in combat aircraft*. AGARD Conference Proceedings No. 134, Soesterberg, Netherlands, September 1973.
- Weiss, H.S., Edelberg, R., Charland, P.V., & Rosenbaum, J.I. Animal and human reactions to rapid tumbling. *Journal of Aviation Medicine*, 1954, 25, 5-22.

CHAPTER 23

AIRCRAFT MISHAP INVESTIGATIONS

Introduction
Classification of Mishaps
Aircraft Mishap Board (AMB)
Premishap Preparation
The Mishap Investigation
Mishap Reports
Special Responsibilities
References and Bibliography

Introduction

By the time the last helicopter arrived at the Desert One rendezvous site, they were one hour and twenty-five minutes late because of the dust storm....Imagine the hostile, alien darkness; the blowing sand from the six helicopters and the four transport aircraft still on the ground, all of their engines turning; the heat and sweat and noise; the piles of heavy equipment such as camouflage nets; and the fear and the haste and the disappointment One of the helicopters, after refueling from a tanker C-130, needed to reposition itself for the trip back to the carrier. All through the night the Marine pilots had had trouble moving their helicopters about in the dark....Now, as the pilot started to fly his bird out from behind the C-130, he became disoriented in the blackness thickened by dust stirred up by his and the tanker's engines. His helicopter tilted right. Its blade cut into the flight deck and left side of the C-130 and flames spurted out....The men in the plane had their equipment off and were lying down on the rubber, waterbed-like partially full gasoline bladders. They felt a slight thump, thump. Most felt relief at first, thinking, Here we go at last, leaving the tension and the failure behind, finally taking off. Then a shower of sparks came tumbling aft into the body of the plane from the pilot's compartment.

That is how Arthur T. Hadley, in his book *The Straw Giant*, described the beginning of the mishap that killed eight members of the failed Iranian rescue mission team. It was a typical aircraft mishap: multiple factors colliding into a confusing horror. Investigating these aircraft mishaps is extremely difficult, time-consuming and stressful. Nevertheless, a thorough investiga-

tion is absolutely necessary if we are to discover what went wrong and devise ways to prevent it from happening again.

Aviation is dangerous. The Navy spends considerable time, effort and money to minimize risks and to stop the needless loss of lives and material. Over the years these efforts have paid off -- the mishap rate has progressively declined (Table 23-1). Yet with each passing year, many of our aviation colleagues are injured and killed and millions of dollars are lost through damaged and destroyed aircraft. The purpose of the Naval Aviation Safety Program (OPNAVINST 3750.6) is to preserve human and material resources. Thus, the program directly impacts all aspects of naval aviation, particularly operational readiness. The program seeks to eliminate the causes of damage and injury, that is, hazards. The aircraft mishap investigation seeks to uncover the hazards that caused the mishap and to make recommendations to prevent a recurrence. If the program were completely successful, there would be no mishaps.

Table 23-1

Navy & Marine Yearly Major/Class A Flight Mishap Statistics

Year	Rate per 100,000 flight hours
1937	88.17
1942	41.01
1947	79.63
1952	54.83
1957	30.53
1962	15.52
1967	13.64
1972	9.46
1977	5.40
1982	4.41
1987	3.25
1988	2.12

With advancing technology, all weapons systems, and particularly aircraft, have become more sophisticated and expensive. And, in a way, waging war has become much more efficient. For example, during World War II one bombing mission included 291 B-17s. Two hundred twenty-eight

Aircraft Mishap Investigation

arrived on target and inflicted minimal damage. Sixty aircraft were shot down and more than 600 crewmen lost. The same mission could be flown today using eight F/A-18s. Still, the dollar cost per mishap goes up every year (Figure 23-1).

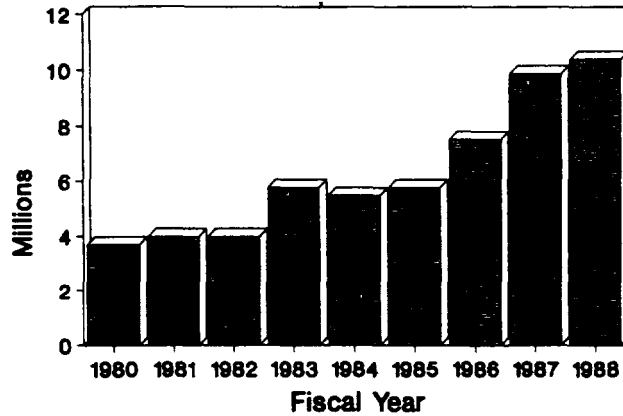

Figure 23-1. Dollar cost per Class A mishap.

Classification of Aircraft Mishaps

A naval aircraft mishap is defined in OPNAVINST 3750.6 as an unplanned event or series of events, directly involving naval aircraft, which results in at least \$10,000 damage or an injury that results in at least one lost workday.

Categories of Mishaps

Mishaps fall into three categories:

1. *Flight Mishap (FM)*. Flight mishaps are those mishaps in which there was \$10,000 or more aircraft damage, and intent for flight existed. Other damage, injury or death may have occurred.
2. *Flight Related Mishap (FRM)*. Flight related mishaps are those mishaps in which there was less than \$10,000 aircraft damage, there was intent for flight, and there was \$10,000 or more total damage, or death, or injury resulting in at least one lost workday.
3. *Aircraft Ground Mishap (AGM)*. Aircraft ground mishaps are those mishaps in which no intent for flight existed, and there was \$10,000 or more total damage, or death, or injury resulting in at least one lost workday.

Examples of Mishaps

An example of a flight mishap (FM) would be an A-6 on a night low level flight that impacts a ridge line. An example of a flight related mishap (FRM) would be a helicopter dragging a rapeller across the ground and into a tree line, killing the rapeller. An example of an aircraft ground mishap (AGM) would be someone doing routine maintenance on an aircraft and falling off, fracturing his femur.

Mishap Severity Classifications

Mishaps are also classified by severity:

1. *Class A.*
 - a. Aircraft destroyed or missing, or
 - b. A fatality occurs or there is an injury that results in permanent total disability, or
 - c. The total cost of damage is \$1,000,000 or greater.

2. *Class B.*
 - a. An injury that results in permanent partial disability, or
 - b. Hospitalization of five or more personnel, or
 - c. The total cost of damage is \$200,000 or more, but less than \$1,000,000.

3. *Class C.*
 - a. An injury that results in one or more lost workdays, or
 - b. The total cost of damage is \$10,000 or more, but less than \$200,000.

Importance of Mishap Severity Classifications

There is a tendency to downplay the importance of a mishap investigation when the amount of damage or injury does not meet the criteria for a Class A mishap. There is not necessarily a correlation between the severity of the mishap and the potential for damage or injury inherent in the hazards detected during the investigation of the mishap. We often lose sight of the goal of a mishap investigation -- to prevent the next mishap from occurring, one that would be much more severe than the one under investigation. The investigative effort therefore should not be tailored to the severity of the mishap; rather, it should be aimed at identifying the hazards of the mishap.

Aircraft Mishap Board (AMB)

Human factors errors cause more mishaps than any other single source of aviation hazards

Aircraft Mishap Investigation

(Figure 23-2). As a member of an Aircraft Mishap Board (AMB), the flight surgeon is primarily responsible for that area of investigation most likely to yield results: the medical and human factors portion. In this capacity the flight surgeon must determine and weigh the importance of human factors involved in the mishap. This process involves an investigation of the aircrew from a biological and psychosociological standpoint, an investigation of the effectiveness of protective equipment and clothing and many other factors. Aircraft mishaps almost always involve a breakdown of one or both of two complex "machine" systems working together: the aircraft and its systems or the pilot and his systems. Since the latter is a much more complicated machine, the flight surgeon's task is very difficult.

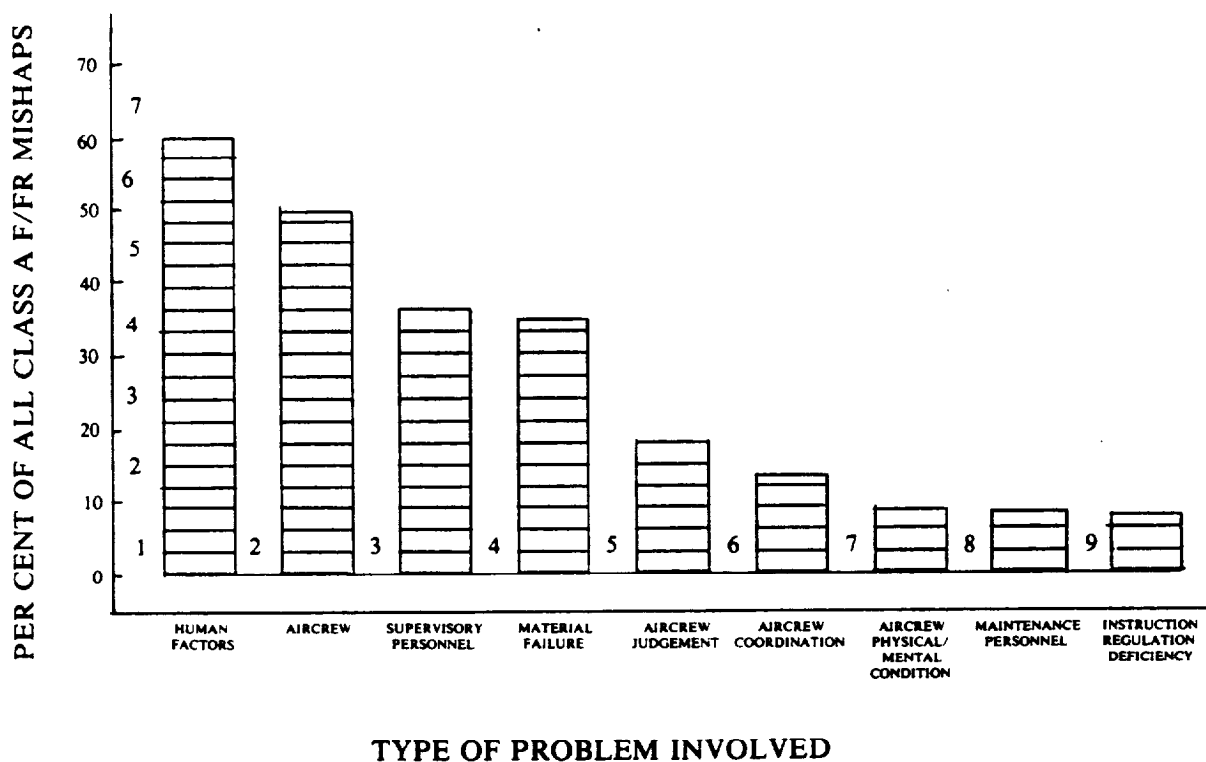

Figure 23-2. Class A F/FR mishaps cause comparison CY 1979-1989.

Flight surgery, as a distinct field, developed because the treatment of aviators and understanding the unyielding environment in which they work demands physicians with specialized training. In a way, flight surgeons exist to detect medical and other human hazards that cause mishaps. When there has been a mishap, it reveals that hazard detection (and elimination) did not take place; after the mishap, those steps must be taken to prevent a recurrence. Hazard detection following a mishap is accomplished through mishap investigation.

U.S. Naval Flight Surgeon's Manual

Investigating aircraft mishaps is a team effort. The AMB has a spectrum of expertise, and the participation of all board members is needed to assess the many complex human and mechanical factors involved in a mishap. The AMB consists of at least four members:

1. An aviation safety officer.
2. An aviation maintenance officer.
3. An aircraft operations officer.
4. A flight surgeon.

To assure that the investigation is as objective as possible, anyone who was directly involved or has a personal interest in a mishap may not serve on the AMB. Mishap investigation and reporting responsibilities of AMB members take precedence over all other duties. Also, AMB members may not be assigned as members to any other investigation (e.g., JAG) of the same mishap.

Each member brings his expertise and perspective to answer the questions raised by the mishap. There is no substitute for the aeromedical safety perspective that a well-prepared flight surgeon can bring to the mishap investigation team, especially a flight surgeon who knows his squadron and aircraft. Because of his medical training, the flight surgeon is well prepared for the detective-like work of a mishap investigation. This is particularly true in the many "gray" areas the AMB will encounter as it struggles to piece the evidence together. He is also the most experienced interviewer on the AMB. And, after a fatal mishap, only the flight surgeon participates directly in all three autopsies:

1. Autopsy of the aircraft.
2. Autopsy of the mission.
3. Autopsy of the man.

The close observation and attention to detail stressed throughout a physician's training, enabling him to establish a diagnosis in a difficult case, are the same skills that must be brought to bear on a mishap. Mishap investigation is essentially a difficult problem in differential diagnosis.

The flight surgeon's responsibility is to analyze the human factors leading to the mishap and those affecting the aircrew during the egress, survival, and rescue phases following the mishap. He assists the AMB through the analysis of remains, as well as analysis of the medical and psychological issues. He also assesses human capacity as compared to the demands imposed. The flight surgeon assumes the role of case manager, and will consult with the other board members as the investigation progresses. Often with the help of an Aeromedical Safety Officer (AMSO), he will also evaluate life-support equipment and the escape or egress, survival, and rescue sequences of the mishap.

Aircraft Mishap Investigation

The AMB is essentially a committee and therefore subject to all of the pitfalls that such “clusters” present: individual and group biases, conflicts between people, lack of leadership, group pressures, “group think,” preconceived ideas, parochial attitudes, and role conflicts. Brainstorming and independent thinking should always be encouraged. Someone should play the devil’s advocate to challenge ideas. Because in many ways he is the most independent member of the board, the flight surgeon often plays this role in group discussions. Each member must be on his guard to keep an open mind and maintain the “big picture” so that the AMB’s investigation is as thorough as possible. And although it is a team, the AMB is not a democracy and the Mishap Investigation Report (MIR) is ultimately the responsibility of the board’s senior member.

A thorough and comprehensive investigation frequently requires the consulting services of other specialized personnel, such as technical representatives from aircraft companies. Only information deemed absolutely necessary will be provided to consultants; privileged or sensitive information should be limited to the AMB (see discussion of privilege later in this chapter). However, all information, including privileged information, is to be shared with Naval Safety Center investigators and Armed Forces Institute of Pathology (AFIP) aerospace pathologists.

Investigators tend to want to find “the cause” of a mishap -- if only it were that simple. Mishaps rarely happen because of a single act or omission or because of a single mechanical failure. Most mishaps result from a mosaic of cause factors that blend to form a tragic picture. All pieces of the mosaic, that is all cause factors, play equal roles in causing a particular mishap. Without any one of them the picture would be incomplete and there would be no mishap. Do not try to rank causal factors such as “direct,” “primary,” or “contributing.” All cause factors are considered to be “under human control.” Thus, as defined, all hazards can be eliminated and all mishaps can be prevented. Therefore, environmental conditions per se are not hazards. For example, it is not wind shear that is the hazard but rather our inability to anticipate, detect or respond to it.

Privilege

All naval aircraft mishap investigations are conducted solely for safety purposes. The success of the Naval Aviation Safety Program depends on complete, open, and forthright information and opinions. The privileged status of information acquired by the AMB is one of its most important tools in getting complete cooperation from witnesses and others.

The Naval Safety Center determines the privileged or nonprivileged status of all information contained in the MIR. All questions concerning privilege should be directed to the Naval Safety Center.

Privileged information is information provided under a promise of confidentiality, or information which would not have been discovered but for information provided under a promise of confidentiality. The deliberative analyses of the findings, conclusions, and recommendations of the AMB are privileged. Also privileged is information directly calculated or developed by the AMB, and information that would reveal the AMB's deliberative process. Information is designated as privileged to overcome any reluctance on the part of mishap participants, witnesses, investigators, and endorsers to reveal complete and candid information, opinions and recommendations about a mishap. If aircraft mishap investigators were unable to give an assurance of confidentiality, or if their promises were hollow, then input from witnesses, AMB members, endorsers, and others often would be incomplete or false; a determination of the exact cause factors of a mishap would be jeopardized and the recommendation for corrective actions would be compromised.

Privileged information must be protected against any use other than safety. The exercise of command influence to edit, modify, or in any way censor the content of MIRs is contrary to the spirit of the Naval Aviation Safety Program and is prohibited. AMB members may not, nor may they be requested to, divulge their opinions, or any information they arrived at, or to which they became privy, in their capacity as members of an AMB. Unauthorized disclosure of privileged information is a criminal offense punishable under Article 92, Uniform Code of Military Justice (UCMJ).

Premishap Preparation

As naval aviation has improved, mishaps have become less frequent (Table 23-1). However, this success is naturally accompanied by an overall reduction in the level of experience of those investigating mishaps. Developing and maintaining sharp investigative skills therefore becomes progressively more difficult. With the rapid sequence of events following a mishap, committing errors that are due simply to a lack of experience can become more common. Consequently, preparedness becomes increasingly important if we are to continue to make progress in eliminating mishaps. Fortunately, there are many things a flight surgeon can do to avoid the pitfalls encountered in these frequently chaotic situations.

The flight surgeon should first become familiar with the Naval Aviation Safety Program (OP-NAVINST 3750.6) and corresponding local instructions. A working knowledge of the program, its definitions and terminology is invaluable.

The flight surgeon must have a thorough understanding of the mishap response plans and capabilities of his local medical facility, squadron and air station. Local flight surgeons should have input into these plans. As part of his premishap planning the flight surgeon should:

Aircraft Mishap Investigation

1. Be thoroughly familiar with the aircraft, life-support systems, mission, and fellow members of his squadron.
2. Be an active member of his squadron's AMB.
3. Be thoroughly familiar with his squadron premishap plan; he must ensure that the medical portion is adequate.
4. Periodically review the local medical facility's mass casualty and premishap plans to ensure their adequacy and see that they are tested with regular drills.
5. Ensure that the local lab is prepared to process post-mishap lab sample collection efficiently.
6. Identify local key personnel (such as an aeromedical safety officer) and have their phone numbers at hand.
7. Identify the local coroner or medical examiner, determine jurisdiction of remains in the local area, and have on file important phone numbers and letters of agreement concerning jurisdiction.
8. Have the names and phone numbers of key personnel at the Naval Safety Center and AFIP readily available.
9. Identify the nearest trauma and burn center, hyperbaric chamber, and backup facilities.
10. Review search and rescue (SAR) procedures and equipment.
11. Review medevac (air and ground) procedures and equipment.
12. Ensure that coordination with both military and civilian medical, fire, rescue, and security staff is adequate.
13. Ensure the adequacy of the aeromedical mishap investigation kit (see discussion of mishap kit below).
14. Ensure that his immunizations and passport are current.
15. Review all of the above before major deployments.

Under the leadership of the squadron safety officer, the board members should meet periodically to conduct training, review policies, and update procedures. The jurisdiction of remains is too often ignored. Don't ignore it. The flight surgeon should establish a working relationship, based on premishap agreement, with the local coroner or medical examiner.

Premishap training should include all pertinent medical staff members such as aviation corpsmen, emergency room staff, and watch standers. They should have checklists that will help them respond without undue disorganization and possible loss of evidence.

A well-stocked and organized aeromedical mishap response kit can save time, reduce confusion, and help preserve evidence. Mishap investigation kits should be compact, portable (fit in a briefcase, backpack, or field medical pack), and ready for immediate use. The precise contents will depend on the geography, aircraft type, and mission. Consider the lists in Tables 23-2, 23-3, and 23-4 in developing your own kit.

The Mishap Investigation

Once a mishap has occurred, the flight surgeon will find many duties thrust upon him; some require immediate attention, others may be delayed.

The flight surgeon's first priority is the medical care of the survivors. Physical exams should be made of all survivors with supplemental laboratory and radiological studies as indicated. Sometimes, initially it seems pointless to draw the required postmishap specimens. However, keep in mind that blood and urine collected late is of little or no value to the investigation. "When in doubt, have it sucked out." Deceased crew members should not be moved before being photographed and examined by the flight surgeon at the mishap site. The flight surgeon should interview and tape statements from each member of the aircrew and possibly others (for example, passengers, air traffic controllers, or plane captains) recounting the mishap from, at least, brief to rescue. Each aircrew member should be instructed to complete a chronological account of his activities for the 72 hours before the mishap. Interviewing witnesses should begin as soon as possible. The flight surgeon should impound medical and dental records as well as flight equipment.

If there are fatalities, the flight surgeon should contact the local coroner (or medical examiner), AFIP, and the Naval Safety Center's Aeromedical Division as soon as possible. Notifying the next of kin is the responsibility of the commanding officer; however, a flight surgeon usually accompanies him.

Table 23-2

Flight Surgeon Mishap Investigation Kit Suggested Contents

Personal I terns:

Insect repellent	Heavy work gloves
Chapstick	Mints or gum
Sunscreen	Flashlight (bulb, batteries)
Sunglasses	

Recording, Plotting or Recovery Items:

Ruler (clear plastic)	Surgical gloves and masks
Pens, magic markers	Blood drawing kits, at least 3 (see Table 23-3)
Pencils (lead and grease) and sharpener	Lensatic compass
Scissors	Graph paper (polar, grid)
Scalpel and blades	Tape measure (100 feet)
Forceps	Body bags and liners
Aircraft model	Plastic bags, self-sealing (various sizes)
Camera, 35 mm SLR (28-85 mm and macro lenses)	C-60 and C-90 cassettes (C-120 break easily)
Camera, Polaroid (SX-70)	Tape recorder with digital counter
Film, (color)	Fresh and spare batteries
Camera flash	Stakes and tags

References and Forms:

Postmishap aeromedical questionnaires	OPNAVINST 3750.6
Memorandum notebook (small)	MIR enclosure forms
Index cards	AA forms
SF 600 forms (progress notes)	AA enclosure 01 forms (72-hour history)
Grounding notices (down chits)	SF 523 forms (authorization for autopsy)
Clearance notices (up chits)	Inventory of kit
Advice to witnesses forms (Appendix 6A in 3750.6)	Flight surgeon Mishap Investigation Pocket Reference

Table 23-3

PostMishap Blood and Urine Collection Kit

-
- 1 Prepackaged Bag for Each Individual Containing at Least:
- 3 Red-top blood collection tubes
 - 2 Lavender-top blood collection tubes
 - 2 Gray-top blood collection tubes
 - 1 Urine cup
 - Betadine swabs
 - Sterile 2 x 2's
 - Tourniquet
 - Venipuncture syringe
 - Needles
 - Labels
 - Lab chits
 - Blood drawing instructions
 - 3 Toxicological exam forms (DD 1323)
-

Table 23-4

Other Items Often Useful at the Mishap Site

Rubber bands	Inspection (dental) mirror
Fluid sample bottles	Small parts brush
Air navigation plotter	Banner guard ("Caution -- Do Not Enter")
Aircraft NATOPS manual	"No Smoking" signs
Aircraft parts catalog	Goggles
Styrofoam boxes	Ear plugs
Medical "black bag"	Chalkboard and chalk
First-aid kit	Toilet paper
Snakebit kit	Magnifying glass
Head covering	Pocket knife
Poncho	Protractor
Water (canteen)	Pocket calculator
Food (MREs and food bars)	Chemical lights
Industrial dust masks	Calipers

Aircraft Mishap Investigation

At the mishap site itself, the flight surgeon must be sure that the wreckage poses no further danger before approaching it. The triage, initial treatment, movement, and evacuation of casualties under the supervision of the flight surgeon then takes place. The wreckage should be disturbed as little as possible; in fact, all members of the AMB should keep their hands in their pockets during their first walk through the mishap site. Photograph the mishap site with impunity. There is no easier or more economical way to illustrate, record, or verify evidence, particularly perishable evidence. Film is cheap and you don't have to have all the negatives printed. The relationships of the aircraft wreckage and bodily remains at the mishap site should be documented before anything is moved.

There is an initial, and very understandable, emotional response by the first people on the scene to do something about the body. It is quite difficult for most people to begin any systematic examination of the mishap while the deceased remains in the wreckage. Nevertheless, the body of the deceased should be covered and left where it is until photographs are taken. Depending upon local jurisdiction, it may be improper to move remains until they are evaluated by the local coroner or medical examiner. As a rule, lab specimens should not be collected at the scene. The controlled environment of a medical facility is the proper place to collect body fluids for lab studies.

Likewise, do not try to dismantle aircraft parts in the field. To ensure a thorough engineering investigation, do not open or remove components except at the Naval Air Depot (NADEP) where engineers, tools, and laboratories are available and the disassembly can be conducted and recorded accurately. Never allow anything to touch the fracture surfaces of broken parts. Never put broken parts back together again. Preserve the fracture surfaces unaltered for examination by a failure analyst. All inquiries by the news media should be handled by the public affairs officer (PAO) or the senior member of the AMB.

Other postmishap responsibilities of the flight surgeon include coordinating with the AFIP aerospace pathology mishap investigation team and assisting at the autopsy. The flight surgeon should ensure that adequate refrigeration facilities are available. Dental and fingerprint comparisons must be made to help make positive identification of mishap victims. Full body radiographs of all deceased should be obtained both in and out of flight equipment with emphasis on hands, feet, head and neck. Special views should be taken as indicated. Radiographs often enable the investigator to determine who was operating the aircraft controls at the time of the mishap and estimate the magnitude and direction of impact forces. Lab specimens from fatalities and survivors should be submitted to AFIP as appropriate.

The flight surgeon may be involved in the search for and recovery of remains. All injuries should be documented and classified. Correct identification of injuries and an accurate analysis

of their pathogenesis provide invaluable data for designers of protective clothing, equipment, and escape systems. Correlating injuries with damage to personal gear is an essential part of the investigation and can lead to design improvements. This is true whether or not a particular injury was directly lethal. For example, an injury may have made egress impossible even though not in itself fatal.

If a lab result is abnormal, the flight surgeon must determine whether or not the abnormality represents a mishap factor, and why.

A chronological account of activities of the previous 72 hours should be constructed for all aircrew. The flight surgeon must maintain close follow-up of those involved to monitor any changes in their medical condition and to obtain further elaboration on the mishap events. The interviewing of witnesses, survivors, friends, and colleagues should continue. The flight surgeon should keep in touch with the AFIP team and the Naval Safety Center's Aeromedical Division as needed throughout the investigation. The flight surgeon must remain sensitive to the psychological trauma a mishap may inflict, particularly among those participating in recovery of the remains. He should counsel them himself or refer them to other health care providers as appropriate.

Mishap Reports

In addition to writing the aeromedical analysis (AA), the flight surgeon must contribute fully to the AMB and the drafting of the Mishap Investigation Report (MIR).

The Mishap Investigation Report

The investigation of human factors issues is not necessarily limited to the aircrew. For example, a mishap can occur because of errors by air traffic controllers, maintenance personnel, or supervisors. The possibilities must be considered and, if necessary, those noncrew members should be interviewed, have physical exams, and have toxicology or other lab tests conducted. As a hypothetical example, an air traffic controller (ATC) may have given an aircrew erroneous information which resulted in a mishap. Possibly the ATC was on a disorienting medication, or had untoward stresses related to training, management, or family matters.

Survivability considerations the flight surgeon must address include decelerative and impact forces, restraint systems function, the retention of occupiable space, the postcrash environment, egress system effectiveness, and other survival problems. An aeromedical safety officer (AMSO) is particularly helpful in evaluating these areas.

Aircraft Mishap Investigation

Anyone who might shed light on any of the causes of the mishap or its associated damage and injury should be interviewed: eyewitnesses, aircrew, passengers, friends, peers, family members, supervisors, air traffic controllers, maintenance personnel, rescue personnel, etc. Interviewing should begin as soon as possible after the mishap. The interview should preferably occur at the spot where the witness was at the time of the mishap to stimulate state-dependent memory. If not there, then interviewing should be conducted in a quiet and private place. Ideally, interviews should be one-on-one and taped. Witnesses are not to provide statements under oath; requiring them to do so is prohibited. Repeat interviews are always needed to confirm, clarify and elaborate concerns as the investigation matures.

The first few days of an investigation should be devoted to gathering all possible information concerning the mishap as if no specific cause was suspected. Resist the inclination to gather information to support initial impressions, thereby overlooking other important evidence.

After the first few days, the pace of the investigative effort tapers off somewhat for the flight surgeon while it is just getting into high gear for the AMB in full. The flight surgeon must remember that he is part of a team and should make every effort to contribute to all AMB meetings. Getting a handle on the tremendous amounts of data that a mishap investigation generates can be quite a challenge to all board members. There is, however, a device to help you organize information during the early phases of the investigation: categorize data and presumed causal factors into one of “5 Ms”:

- Man
- Machine (aircraft)
- Manuals
- Media (environment)
- Mission.

Another way to help organize this information is to envision the mishap as the last in a series of domino-like events and work back one event at a time, trying to arrive at the most basic causes.

The findings that the AMB discovers are only worth as much as the report they are presented in. As in medicine, an unsupported diagnosis itself is not only inadequate but dangerous. The entire clinical history, laboratory findings, consultations, etc., are needed. Similarly, in aircraft mishaps, the entire story must be presented in an effective manner. The report that the AMB drafts is called the Mishap Investigation Report (MIR). An MIR is submitted for each naval aircraft mishap. The purpose of an MIR is to report hazards that were either the causes of the mishap or which were the causes of damage or injury occurring in the course of the mishap. The MIR also provides recommendations to eliminate or reduce the severity of those hazards.

U.S. Naval Flight Surgeon's Manual

An MIR reflects a pattern of deductive reasoning in its 13 "paragraphs." The first nine describe the background facts of a mishap: for example, the rank and age of mishap participants, weather conditions in which the mishap took place, and a short statement of what happened. Examples of information that should not be included in these first nine paragraphs are opinions of the AMB, witness statements, or engineering investigation conclusions. Paragraph 10 covers what the AMB knows (evidence) by presenting everything relevant about the event under investigation, usually in chronological order. Opinions of the AMB are not permitted in paragraph 10. Paragraph 11 is the analysis section and presents the thought process of the board. All possible cause factors that the AMB considered, whether accepted or rejected, are discussed. Paragraph 12 lists the board's conclusions. Cause factors of the mishap and cause factors of damage and injury occurring in the course of the mishap are listed. Paragraph 12 is essentially a listing of all the accepted cause factors from paragraph 11. Every conclusion in paragraph 12 should lead to at least one recommendation in paragraph 13. Each recommendation should state who should do exactly what and, ideally, how and when. The board should make specific and definitive recommendations to prevent a similar mishap and its associated damage and injury from happening again.

Table 23-5

MIR Enclosure Forms

01	General information data
02	Individual background data
03	Medical information
04	Aviation physiology, egress, and water survival training data
05	Aviation life support systems data
06	Escape, egress data
07	Ejection or bailout data
08	Survival and rescue data
09	Aircrew data
10	Aircraft data
11	impact data
12	Night vision device data
13	Meteorological data

There are 13 enclosure forms to the MIR (Table 23-5). They serve as a ready source of information for input to the Naval Safety Center data bank. They are important for research and trend

Aircraft Mishap Investigation

analyses. They also provide details and background data to support the MIR and aeromedical analysis (AA). Certain MIR enclosure forms must be submitted on each individual involved in the mishap. Although these enclosure forms are the responsibility of the entire AMB, most are based on the now-obsolete flight surgeon report (FSR) forms. Some of these forms are clearly medical in nature, requiring the flight surgeon to lead the work on them.

Aeromedical Analysis

The aeromedical analysis (AA) is a privileged enclosure to the MIR. It is a report by the flight surgeon, documenting pertinent aeromedical conditions, and discussing the causes of the mishap and associated damage and injury. This AA is a report from the flight surgeon to the senior member of the AMB, MIR endorsers, and the Naval Safety Center. Although primarily concerned with medical, physiological, behavioral, psychological, and social factors, in addition to the escape, survival and rescue of the individual, the flight surgeon's investigation and the aeromedical analysis are not limited to those aspects of the mishap. The collection and analysis of medical and human factors evidence must be coordinated with all other aspects of the investigation. The AA and other portions of the MIR should be complementary but they are also expected to overlap somewhat. All members of the AMB should participate to some extent in the completion of both the MIR and the AA. The format for the AA should generally follow this outline:

- Review of Events.
- Discussion of Aeromedical Conditions.
- Aeromedical Conclusions.
- Aeromedical Recommendations.
- Enclosures to the AA.

Review of Events: The AA review of events is a brief chronological review of the entire mishap sequence of events. The review should look at events or factors from before and after the mishap, with a wide enough scope to include all of the causal factors of the mishap and all the causal factors of damage and injury that occurred in the course of the mishap. Thus, this section may begin with a discussion of a pilot's preexisting medical condition which may predate the mishap by years. As a minimum, this section should begin with the flight planning. The review should not end without detailing the egress, rescue, and medevac phases, and describing when and how the survivors came under appropriate medical care. The review should include a brief medical and psychological profile of each person involved. The flight surgeon may review sensitive, personal, and speculative topics in this section. From this AA review of events, the reader should be able to understand the sequence of mishap events readily without referring to other documents. The background of those who will read the AA is quite diverse, so avoid jargon that may confuse some-

U.S. Naval Flight Surgeon's Manual

one who is not intimate with medicine or the mishap aircraft community. Use only common abbreviations, spelling them out with first use. Items in this section that should be commented on for each person include:

- Summary of the 72-hour account of activities.
- Summary of physiology training.
- Postmishap physical examination findings.
- Flight physical (most recent) findings.
- Physical qualification waivers.
- Summary of life stressors.
- Relationships with coworkers, family, and friends.
- Acute and chronic medical problems.
- Use of medications.
- Use of alcohol.
- Biological sample results.
- Autopsy reports.
- Escape, egress, or survival episodes.
- Aviation life support systems (ALSS) usage and problems.
- Search and rescue (SAR) effort.
- Treatment and transport of the injured.

Discussion of Aeromedical Conditions. In this section the flight surgeon discusses all of the pertinent aeromedical conditions of the mishap. Mishap causal and mishap noncausal factors are discussed. The flight surgeon may include sensitive, personal, or speculative topics in this section.

Aeromedical Conclusions. Based on the discussion section all present aeromedical conditions, whether causal or noncausal of the mishap, and additional damage or injury are listed.

Aeromedical Recommendations. Each causal aeromedical condition should lead to at least one recommendation. The aim of recommendations should be to prevent a similar mishap or damage or injury from recurring. Recommendations should also be made that would reduce or limit the severity of damage or injury. Like MIR recommendations, aeromedical recommendations should be as specific as possible in stating who should do what and, ideally, how and when.

Enclosures to the AA. Supporting documents should be held to a minimum. However, the following privileged enclosures may be necessary to support the AA:

- Chronological account of activities of the previous 72 hours (AA enclosure form 01).
- Witness or survivor statements.

Aircraft Mishap Investigation

- Medical record extracts.
- AFIP reports.
- Postmishap physical examination report.
- Reports detailing personal or sensitive material.
- Photographs of a sensitive nature, such as autopsy photographs.
- Diagrams and photographs of the aircraft and mishap site.
- Engineering investigation (EI) reports of ALSS.
- Survivor statements concerning escape, survival, and rescue episodes.
- Other privileged documents that clarify or support the AA.

Special Responsibilities

Confidentiality is an important responsibility that must not be neglected. Rumor and conjecture are common after a mishap. People will want to know all of the details. Some will be heard creating or repeating rumors that the flight surgeon knows to be false. The flight surgeon must resist any urge to stop such rumors by "spreading the truth." Tactful evasion may be the best response.

The mishap investigation is like a differential diagnosis. Only the flight surgeon has had special training in this process. In clinical medicine, one life may be involved; but in aviation mishaps, possibly hundreds of lives and millions of dollars may depend on the thoroughness of your diagnosis and recommended treatment. How the flight surgeon meets the duties and responsibilities of a mishap investigation will affect his appraisal by his peers and seniors in the Navy as an officer and as a physician perhaps to a larger extent than anything else he may do while on active duty. During an investigation, the flight surgeon should demonstrate the same respect for objectivity and confidentiality that is expected of him in his role as a personal physician. If a flight surgeon does nothing more than prevent one major mishap in a 20-year naval career, he will have saved more than his entire pay. While a flight surgeon may never have absolute proof that he prevented a mishap, he must always do his best to prevent damage, injury, and death without the credit or even certain knowledge that he has succeeded.

References

- Amstrong, J.A., Fryer, D.I., Stewart, W.K., & Whittingham, H.E. Interpretation of injuries in the comet aircraft disasters: An experimental approach. *Lancet*, 1955, *1*, 1135- 1144.
- Deaton, J.E. The psychology of Aircraft Mishap Boards. *U.S. Naval Institute Proceedings*, June, 1985, *111*, 105-107.
- Department of Defense. Armed Forces Medical Examiner Systems (DODINST 6010.16 series).

U.S. Naval Flight Surgeon's Manual

- Department of the Navy, Bureau of Medicine and Surgery. Aeromedical Safety Officer Program (BUMEDINST 5100.11).
- Department of the Navy, Naval Air Systems Command. Guide to mishap investigations (NAVAIR 00-80T-116-1).
- Department of the Navy, Naval Air Systems Command. Investigative techniques (NAVAIR 00-80T-116-2).
- Department of the Navy, Naval Air Systems Command. Safety investigation workbook (NAVAIR 00-80T-116-3).
- Department of the Navy, Naval Safety Center. *Aeromedical newsletter*. NAS Norfolk: Naval Safety Center, Aeromedical Division, prepared quarterly.
- Department of the Navy, Naval Safety Center. *Flight deck awareness*. NAS Norfolk: Naval Safety Center, Publications Department, 1987.
- Department of the Navy, Naval Safety Center. *Helicopter safety*. NAS Norfolk: Naval Safety Center, Publications Department, 1987.
- Department of the Navy, Naval Safety Center. *LPH/LHA flight deck awareness*, NAS Norfolk: Naval Safety Center, Publications Department, 1987.
- Department of the Navy, Naval Safety Center. *United States naval flight surgeon aircraft mishap investigation pocket reference* (2nd ed.). NAS Norfolk: Naval Safety Center, Aeromedical Division, 1988.
- Department of the Navy, Naval Safety Center. *United States Navy emergency escape summary*. NAS Norfolk: Naval Safety Center, Aeromedical Division, prepared annually.
- Department of the Navy, Office of the Chief of Naval Operations. NATOPS General Flight and Operating Instructions (OPNAVINST 3710.7 series).
- Department of the Navy, Office of the Chief of Naval Operations. The Naval Aviation Safety Program (OPNAVINST 3750.6 series).
- McMeekin, R.R. Aircraft accident investigation. In De Hart, R.L. (Ed.) *Fundamentals of aerospace medicine*. Philadelphia: Lea & Febiger: 1985, 762-814.
- Von Minden, D.L. Procedural Outline: Collection and Shipment of Specimens for Toxicological Analysis. Armed Forces Institute of Pathology, Division of Toxicology Handout, 1988.

CHAPTER 24

AIRCRAFT ACCIDENT SURVIVABILITY

Introduction

Crash Survivability

Human Tolerance Limits

Survivability Calculations

Reference

Appendix 24-A Basic Trigonometric Functions

Appendix 24-B Deceleration Pulses and Equations

Appendix 24-C Sample Calculations of Landing and Crash Forces

Introduction

The interaction between the crash investigator and the design engineer traditionally is an after-the-fact matter. The information collected at that time, however, can be most valuable. Findings presented in the Flight Surgeon's Report (FSR) of an aircraft accident investigation can lead to the identification of correctable design deficiencies. This is especially true when it can be shown that the crash forces in a fatal aircraft accident should have been survivable. The question then becomes "Why did the death occur?" A flight surgeon, serving as a crash investigator and using proper investigative techniques, can provide the design engineer with a reasonable answer. Possible design corrections then can be addressed, and short-term alterations can be made to improve crash survivability.

Crash Survivability

This chapter presents survivability principles and describes procedures for calculating crash forces. While the calculations more frequently fit aircraft without ejection seats, they are not restricted to such aircraft.

Every FSR should address crash survivability directly. The investigation of injuries and deaths from crashes which can be shown to have been survivable will identify problems such as weak seat-to-floor tiedowns, noncrashworthy fuel systems, helmets that offer marginal head injury protection or that may themselves cause lethal injuries, and rudder pedals that fracture tibia and

hinder escape. For too long it has been assumed that injuries or fatalities naturally occur in accident sequences. It is neither luck nor fate when an aviator survives.

The Components of Survivability

Survivability requires two things: the presence of tolerable deceleration forces and the maintenance of a volume of space consistent with life. This section highlights the mathematics of crash force calculations and considers the elemental components of survivability.

Calculating the crash forces in an accident is an imperfect art. Using known speed, stopping distances, and gravity constants, it is relatively simple to calculate the deceleration forces imposed on an airframe. These numbers must then be viewed from the perspective of the aircrewman for whom other factors serve to increase or decrease the acceleration (G) forces he must tolerate to survive. A reference tool is the acronym "CREEP." The CREEP factors are:

C = Container

R = Restraints

E = Environment

E = Energy absorption

P = Postcrash factors.

The Container. An airframe which disintegrates, allows penetration by objects, or which fails to otherwise preserve an appropriate volume of living space can produce or contribute to injuries. The use in larger airframes of brittle alloys that trade off pressurization integrity for impact resistance has been a source of container problems. Another obvious example is the invasion of the aircrew living space by helicopter transmissions after the main rotor blades strike the ground. The limited space between crew seats and controls, dashboards, or outside objects with which the crew can collide is also a container problem. The thoughtful investigator will evaluate the living space remaining after impact forces have been dissipated, remembering that some ductile metals can rebound after they have compromised volume, leaving few traces of their brief invasion into the aircrew compartment.

The Restraint System. To secure an aircrewman with a system of straps designed to withstand a 10,000 pound load is futile unless the system is maintained and used properly. Worn or damaged

Aircraft Accident Survivability

straps may fail at reduced loading. Unused restraints speak for themselves. Loosely secured restraints present a special problem because of dynamic overshoot. This occurs when the aircraft has begun deceleration over the time before the crewman actually impinges on his straps, which may either fail or rebound. Crash force calculations under the latter circumstances will be in error by at least a factor of two.

Ten thousand pound test straps affixed to a seat which in turn will separate from the floor with a 4 G deceleration in the x-axis, or a 1.5 G deceleration in the y and z-axes, are a complete mismatch. Loose restraints invite submarining in which the aircrewman can exit the seat in whole or in part without unfastening the restraint buckle. Buckles that open under survivable deceleration forces or that cannot be opened with one hand must be identified. Those buckles that cannot be opened if suspended, inverted, or that are so complex as to defy quick opening by nonaircrewman must also be eliminated from the inventory. Inertial reels left unlocked may lock automatically as advertised, but only if the deceleration is in the x-axis, and then only after some amount of travel that equates with dynamic overshoot.

The aft-facing seat, which ostensibly requires a simpler restraint system, must withstand higher G-loading than its forward-facing counterpart because its center of gravity is higher. A seat designed as forward-facing which is installed facing aft will predictably fail under minor G-loads. The side-facing seat exposes its occupant to the least survivable G-loads, restraining systems not withstanding.

The Environment. There are many features of the cockpit environment which affect the ability of an aviator to withstand crash forces. Pyrolyzation products from fires involving electrical insulation and polyurethane sound-attenuating or decorative panels can produce inflight incapacitation which reduces survival chances. The same is true for the volatile hydrocarbons present in a cockpit fire at low ambient pressures, with or without the presence of an open flame. The toxicological properties of substances in a sea level environment may be substantially altered when the event occurs at altitude.

Another environmental factor which influences crash survivability is the speed with which emergency egress can be accomplished. If an aircrewman or a nonaircrewman has been trained in specific emergency exit procedures, and he is then confronted with unanticipated impediments to a fast exit, survival chances decrease. The capability of a crewman to egress rapidly must be considered in assessing survivability.

Energy Absorption. The more energy absorption that occurs in the airframe before the aircrewman's body becomes the absorber, the safer the crewman. Honeycomb construction, stroking seats, and expendable space and metal are a few of the techniques available to the engineer for

increasing survivability. Landing gears that can absorb a sink rate of 35 feet per second are expensive, but they are a reality and will increase the chances for survival.

It is only necessary that energy absorption devices be built to absorb a portion of impact in a 40 G crash; man can normally handle the remaining 20.

Postcrash Factors. Statistically, the single most important postcrash factor affecting survivability is fire. It is a safe assumption that if fire is not yet present at an accident scene, it will be shortly. The atomization of fuels that occurs simultaneously with destructive impact renders all aviation fuels of equally dangerous potential, regardless of flash points, vapor pressures, or other laboratory-measured properties. The U.S. Army has led the way in the evolution of crashworthy fuel systems designed to prevent spillage or atomization. These breakaway, fail-save valves, pipe connections, and tanks, which all prevent escape of fuel, have dramatically changed the previously grim statistics of helicopter postcrash fires. The continued acceptance of belly fuel tanks located beneath or directly adjacent to crew and passenger compartments, where impact and abrasive forces must compromise these spaces, no longer merits tolerance.

Along with the direct thermal effects of fire, the attendant hazards from products of combustion must be recognized. Toxic gases, including carbon monoxide, cyanide, phosgene, and acrolein may all contribute to the injury or be fatal themselves. Carbon dioxide levels will also rise, promoting reflex hyperpnea. Particulate matter and smoke can not only interfere with breathing, but also decrease visibility, hindering egress and rescue efforts.

Use of thermal protective garments and readiness of firefighting equipment both in the aircraft and at the duty runway edge are standard procedures in the military. These measures are substantially less effective, however, than the designing of an airframe to absorb impact without fuel spillage and subsequent ignition. A survivable crash, with mild to moderate G-forces that produce associated limb fractures in passengers and crew, rapidly becomes a tragedy when postcrash fire occurs and timely egress becomes impossible.

There are myriad postcrash factors influencing survivability. Fire is the most important. Others, such as poor communications, inadequate rescue capabilities, water survival requirements, and training problems should be evident to the investigator as problems that may require corrective action on a local level. The problem of postcrash fire, however, remains nearly universal.

Aircraft Accident Survivability

Human Tolerance Limits

In each of the three major axes of acceleration and deceleration, there are “best guess” estimates of human tolerance (Crash Survival Investigators’ School, 1986). These numbers are imperfect because of the indirect methods available for their establishment. As pointed out above, calculations of G-forces imposed on the airframe may bear only limited similarity to the forces imposed on crew and passengers. The human tolerance limits shown in Tables 24-1 and 24-2, along with the CREEP factors, offer an investigator a rule of thumb around which survivability estimates can be made. In using these numbers, it is important to appreciate that as the time of exposure to high-impact forces increases, the tolerance level decreases.

For deceleration, duration of the forces and the rate of onset can significantly alter human response. The body acts like porcelain in short duration exposures with a high rate of onset, but like a hydraulic system in longer exposures with a high rate of onset.

Table 24-1

Deceleration Force Tolerance Limits*

Position	Limit	Duration
Eyeballs-out ($-G_x$)**	45 G	0.1 sec
	25 G	0.2 sec
Eyeballs-in ($+G_x$)	83 G	0.04 sec
Eyeballs-down ($+G_z$)	20 G	0.1 sec
Eyeballs-up ($-G_z$)	15 G	0.1 sec
Eyeballs-left or Eyeballs-right ($\pm G_y$)	9 G	0.1 sec

*Fully restrained subjects exposed to whole-body impact at up to 250 G/sec onset rate. Injury known to occur if exceeded.

**For lap belt restraint only, $-G_x$ tolerance may be cut to 1/3.
(from Crash Survival Investigators’ School, 1986).

Table 24-2

Regional Impact Forces Known
to Cause Bone Fracture or Concussion

Body Area	Force	Duration
Head (frontal bone, 2" diam. application)	180 G	0.002 sec
	57 G	.02 sec
Nose	30 G	*
Maxilla	50 G	*
Teeth	100 G	*
Mandible	40 G	*
Brain (concussion)	60 G	.02 sec
	100 G	.005 sec
	180 G	.002 sec

*Duration figures not available.

(from Crash Survival Investigator's School, Arizona State University, Tempe, Arizona, 1986).

Where the crash forces are not clearly in the x-, y-, or z-axes, it may be appropriate for an investigator to solve for the vector most nearly approaching the actual crash force vector and extrapolate to the likely survivability limits and exposures. Table 24-1 does not present a maximum, or even an average, for survivable crash forces. It does show that level of force which is known to be safe, and beyond which body damage could reasonably be expected to occur. These limits presuppose proper utilization of a four or five-point restraint system by a healthy subject.

The limits shown in Tables 24-1 and 24-2 are not so fixed that to exceed them is automatically equated with nonsurvivability. It is also not valid to extrapolate from these limits directly to the G-forces calculated for a given crash situation. When a decision on the survivability of a given situation must be made, the following considerations may be helpful. If the calculated crash forces on the airframe exceed the human tolerance limits by a factor of two or more, survivability

Aircraft Accident Survivability

is unlikely. If the limits are exceeded by a factor of 0.5, survivability is doubtful. If the limits are exceeded by a factor of 0.25 or less, survivability can be dependent on the CREEP factors. If the limits are not exceeded, survivability is expected, although individual variations in G-tolerance and the CREEP factors still remain extremely important in determining survivability.

Survivability Calculations

The investigating flight surgeon or physiologist is not expected to be an engineer, a maintenance officer, or qualified in the type of aircraft involved in a mishap. Rather, he must use the talents of the other members of the Aircraft Mishap Board and the consultative expertise available to him, to get the data needed for his calculations. Members of the accident investigation team can supply the following information:

1. Initial and final velocities for each impact.
2. Vertical stopping distances, measured in feet, including depth of gouges in the earth, depth of water entry before stop, depth of damage to the underside of the aircraft or extent of compression of energy-attenuation devices, such as oleo struts and stroking seats.
3. Horizontal stopping distances, measured in feet, including length of gouges in the earth, length of airframe compression in the horizontal plane, backward displacement of each wing, empennage surfaces, engine, and fuselage, or actual stopping distance after water entry.
4. The shape of the deceleration pulse which most nearly reflects the buildup and dissipation of stopping forces.

In cases where the Aircraft Mishap Board cannot establish values, the members must estimate a range for the values and make maximum and minimum estimates. Where the range crosses the expected limits of survivability, it may have to be narrowed. For example, if the board concludes that the aircraft was traveling between 80 and 100 knots just prior to impact, and it can be shown that 92 knots is the outside limit of the survivability envelope, it may be necessary to reevaluate the evidence so that a more precise airspeed estimate can be obtained.

Velocity measurements are extremely important because they are squared in the numerators of the survivability equations (Appendix 24-B) and can considerably magnify any errors. Stopping distances that may be relatively short, appearing in equation denominators, similarly need precision and, where possible, should be measured rather than estimated. For convenience, an electronic calculator is recommended to perform the actual mathematics involved, remembering that precision beyond the first decimal place is unrealistic.

Trigonometry

Use of basic trigonometric functions (Appendix 24-A) is necessary to establishing force vectors. A brief review of terminology and useful principles of trigonometry follows:

Hypotenuse. The side of a right triangle opposite the right angle.

Opposite Side. The side opposite a specific angle of a triangle

Adjacent Side. The side touching a specific angle of a triangle.

Sine of an Angle. A fraction using the opposite side dimension as the numerator and the hypotenuse dimension as the denominator.

Cosine of an Angle. A fraction using the adjacent side dimension as the numerator and the hypotenuse dimension as the denominator.

Tangent of an Angle. A fraction using the opposite side dimension as the numerator and the adjacent side dimension as the denominator.

Pythagorean Theorem. In a right triangle, the square of the hypotenuse is equal to the sum of the squares of the other two sides ($a^2 + b^2 = c^2$).

Sum of Angles. The sum of the angles of any triangle equals 180°.

The basic use of trigonometric relationships in establishing the parameters describing an aircraft crash is illustrated in Figure 24-1. If the dimensions of any two sides of the triangle or of one side and the impact angle can be obtained by actual measurement, the other parameters can be calculated.

Deceleration Pulses

The Aircraft Mishap Board should identify the most likely deceleration pulse shape. The decay or increase of the deceleration forces during the time of application must be represented diagrammatically. The various kinds of pulses and the corresponding deceleration equations are illustrated in Appendix 24-B. There are two groups of formulae: the first is used when the final velocity, (V_f) is zero and the second when V_f is not zero. Each case must be treated separately. The following are examples:

Aircraft Accident Survivability

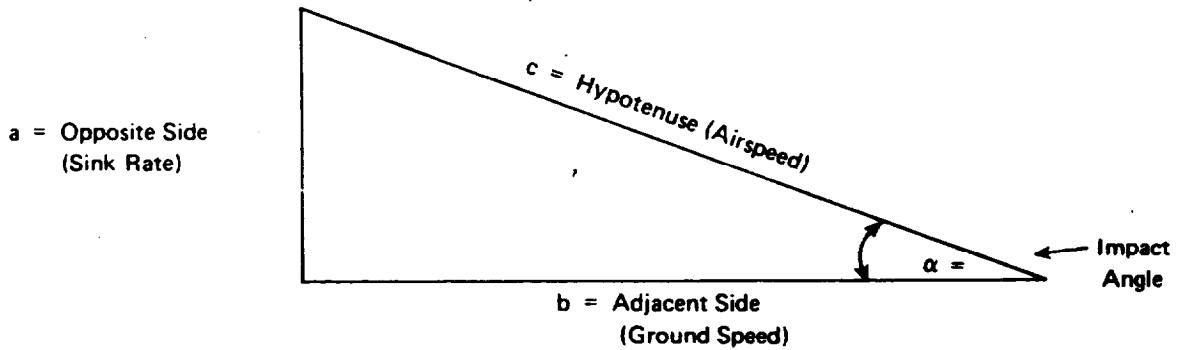

$$\sin \alpha = \frac{\text{Opposite}}{\text{Hypotenuse}} = \frac{a}{c}$$

$$\cos \alpha = \frac{\text{Adjacent}}{\text{Hypotenuse}} = \frac{b}{c}$$

$$\tan \alpha = \frac{\text{Opposite}}{\text{Adjacent}} = \frac{a}{b}$$

The Pythagorean Theorem: $a^2 + b^2 = c^2$

Figure 24-1. Trigonometric relationships used in calculating crash forces.

Rectangular Pulse requires unchanging G-forces over the period beginning with the initial velocity and ending with the final velocity. An example is the deceleration of a normal landing using constant braking force.

Triangular Pulses require constantly changing deceleration levels, either increasing, decreasing, or a combination of both. An example of a constantly increasing force is a crash that digs a deep hole. An example of a constantly decreasing force is impact against an object that gradually gives way like a tree top. A combination of increasing and decreasing forces would be expected as an aircraft flew through trees or brush. Water entry also frequently has increasing then decreasing forces.

Half-Sine Pulse requires constantly changing rate of deceleration as in an arrested carrier landing.

Interpolation of Pulses. If the deceleration pulse of an impact does not match a pulse given in Appendix 24-B, the forces of the two pulses that most closely represent the situation must be calculated. The actual forces are interpolated between those answers as shown in Figure 24-2.

The Board determines the deceleration pulse to be:

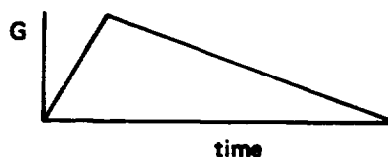

Calculate for:

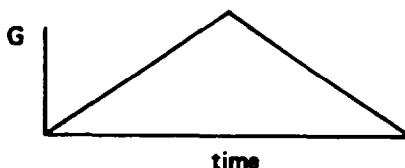

And:

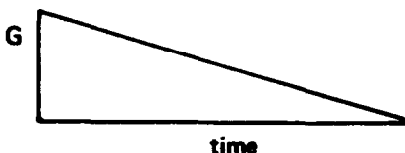

The actual answer will lie between the two.

Figure 24-2. Interpolation of deceleration pulses (from Crash Survival Investigators' School, 1976).

Guide for Problem Solving, Step by Step

The most common errors in calculating crash forces are not mathematical mistakes; they are errors resulting from inattention and inaccuracy. The following steps are offered to make successful calculations more likely:

1. Express all velocities in feet per second (fps) and all distances in feet. The conversion factors are:

Aircraft Accident Survivability

$$\text{mph} \times 1.46 = \text{fps}$$

$$\text{kts} \times 1.69 = \text{fps}$$

2. Draw a large diagram and label every known distance, velocity, and angle.
3. Designate the deceleration pulse or pulse possibilities and the final velocity.
4. Calculate vertical and horizontal velocities.
5. Calculate vertical and horizontal G-forces using the appropriate formulae (Appendix 24-B).
6. Calculate the resultant G-vector from vertical and horizontal G.
7. Calculate the time of the deceleration pulse from the appropriate formula (Appendix 24-B).
8. Estimate survivability potential using Tables 24-1 and 24-2.

The Inadequacies of the Survivability Calculations

Numbers are not magical. They confer scientific precision where it may not be wholly appropriate, and this is the case for survivability estimates. The formulae make no provisions for dynamic overshoot, for example, or for the rebound of cockpit components which might be harmful to the crew. The squaring of estimated numbers in the equations compounds an error by its square. And finally, the human tolerance levels in Tables 24-1 and 24-2 were derived in laboratories, in retrospect, with imperfect and sometimes unrealistic techniques. None of these limitations, however, destroys the usefulness of the calculations. They provide the best available method for approximating the forces acting upon aircraft and crew in crash situations. Examples of landing and crash calculations which may be helpful as models are given in Appendix 24-C.

Reference

Crash Survival Investigators School, 1986.

APPENDIX 24-A

BASIC TRIGONOMETRIC FUNCTIONS

$$\text{Sine} = \frac{\text{Opposite}}{\text{Hypotenuse}}$$

$$\text{Cosine} = \frac{\text{Adjacent}}{\text{Hypotenuse}}$$

$$\text{Tangent} = \frac{\text{Opposite}}{\text{Adjacent}}$$

Angle	Sine	Cosine	Tangent	Angle	Sine	Cosine	Tangent
0°	0.000	1.000	0.000	45°	.707	.707	1.000
1°	.018	1.000	.018	46°	.719	.695	1.036
2°	.035	0.999	.035	47°	.731	.682	1.072
3°	.052	.999	.052	48°	.743	.669	1.111
4°	.070	.998	.070	49°	.755	.656	1.150
5°	.087	.996	.088	50°	.766	.643	1.192
6°	.105	.995	.105	51°	.777	.629	1.235
7°	.122	.993	.123	52°	.788	.616	1.280
8°	.139	.990	.141	53°	.799	.602	1.327
9°	.156	.988	.158	54°	.809	.588	1.376
10°	.174	.985	.176	55°	.819	.574	1.428
11°	.191	.982	.194	56°	.829	.559	1.483
12°	.201	.978	.213	57°	.839	.545	1.540
13°	.225	.974	.231	58°	.848	.530	1.600
14°	.242	.970	.249	59°	.857	.515	1.664
15°	.259	.966	.268	60°	.866	.500	1.732
16°	.276	.961	.287	61°	.875	.485	1.804
17°	.292	.956	.306	62°	.883	.470	1.881
18°	.309	.951	.325	63°	.891	.454	1.963
19°	.326	.946	.344	64°	.899	.438	2.050
20°	.342	.940	.364	65°	.906	.423	2.146
21°	.358	.934	.384	66°	.914	.407	2.246
22°	.375	.927	.404	67°	.921	.391	2.356
23°	.391	.921	.425	68°	.927	.375	2.476
24°	.407	.914	.445	69°	.934	.358	2.605
25°	.423	.906	.466	70°	.940	.342	2.747
26°	.438	.899	.488	71°	.946	.326	2.904
27°	.454	.891	.510	72°	.951	.309	3.078
28°	.470	.883	.532	73°	.956	.292	3.271
29°	.485	.875	.554	74°	.961	.276	3.487
30°	.500	.866	.577	75°	.966	.259	3.732
31°	.515	.857	.601	76°	.970	.242	4.011
32°	.530	.848	.625	77°	.974	.225	4.331
33°	.545	.839	.649	78°	.978	.208	4.706
34°	.559	.829	.675	79°	.982	.191	5.145
35°	.574	.819	.700	80°	.985	.174	5.671
36°	.588	.809	.727	81°	.988	.156	6.314
37°	.602	.799	.754	82°	.990	.139	7.115
38°	.616	.788	.781	83°	.993	.122	8.144
39°	.629	.777	.810	84°	.995	.105	9.514
40°	.643	.766	.839	85°	.996	.087	11.43
41°	.656	.755	.869	86°	.998	.070	14.30
42°	.669	.743	.900	87°	.999	.052	19.08
43°	.682	.731	.933	88°	.999	.035	28.64
44°	.695	.719	.966	89°	1.000	.018	57.29
45°	.707	.707	1.000	90°	1.000	.000	-

APPENDIX 24-B

DECELERATION PULSES AND EQUATIONS

Definitions:

- V_o = initial velocity in fps
- V_f = final velocity in fps
- S = stopping distance in feet
- t = pulse duration in seconds (time to stop)
- G = deceleration force in G

For the Case $V_f = 0$

I. Rectangular Pulse — Constant Deceleration

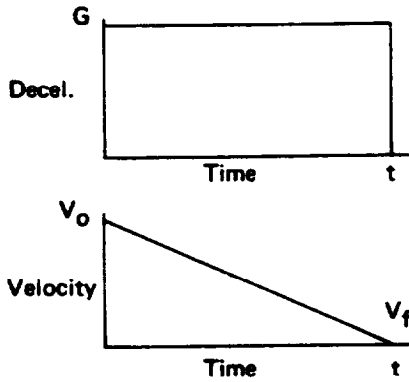

Deceleration Force: $G = \frac{V_o^2}{64.4S}$

Pulse Duration: $t = \frac{V_o}{32.2G}$

II. Triangular Pulses — Constantly Changing Deceleration

Case A — Increasing Deceleration

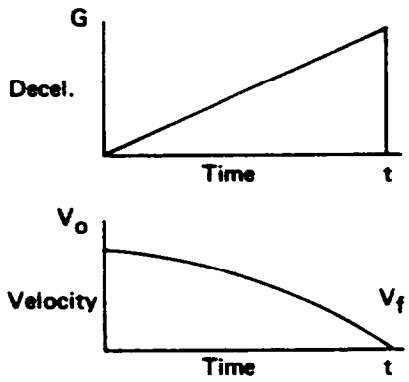

Deceleration Force: $G = \frac{4V_o^2}{96.6S}$

Pulse Duration: $t = \frac{2V_o}{32.2G}$

Case B — Decreasing Deceleration

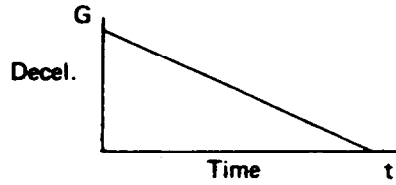

Deceleration Force: $G = \frac{2V_o^2}{96.6S}$



Pulse Duration: $t = \frac{2V_o}{32.2G}$

Case C — Increasing and Decreasing Deceleration

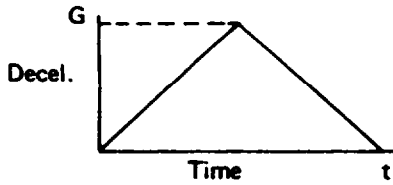

Deceleration Force: $G = \frac{V_o^2}{32.2S}$

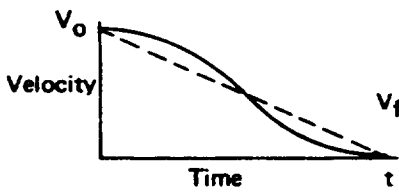

Pulse Duration: $t = \frac{2V_o}{32.2G}$

III. Half-sine Pulse — Constantly Changing Rate of Deceleration

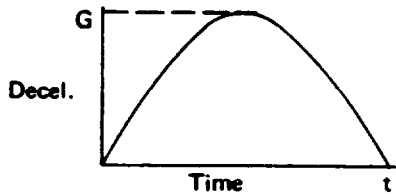

Deceleration Force: $G = \frac{.7854 V_o^2}{32.2S}$

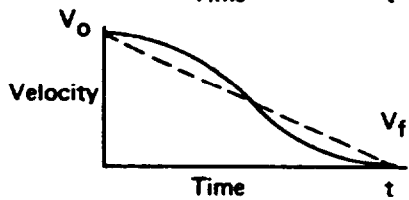

Pulse Duration: $t = \frac{1.57 V_o}{32.2G}$

For the Case $V_f \neq 0$

I. Rectangular Pulse — Constant Deceleration

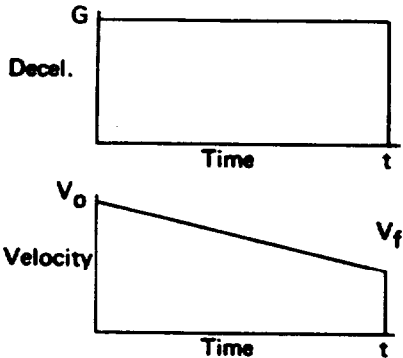

Deceleration Force: $G = \frac{V_o^2 - V_f^2}{64.4S}$

Pulse Duration: $t = \frac{V_o - V_f}{32.2G}$

II. Triangular Pulses — Constantly Changing Deceleration

Case A — Increasing Deceleration

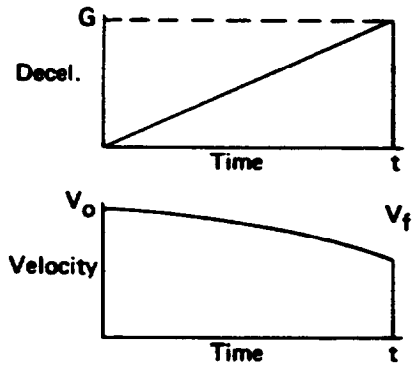

Deceleration Force: $G = \frac{4V_o^2 - 2V_oV_f - 2V_f^2}{96.6S}$

Pulse Duration: $t = \frac{2(V_o - V_f)}{32.2G}$

Case B — Decreasing Deceleration

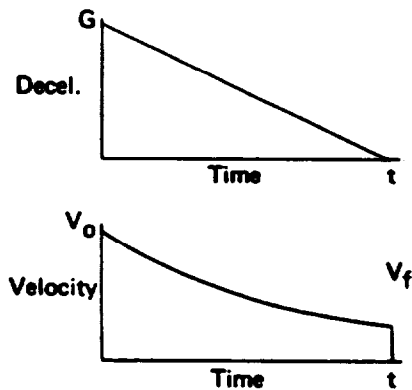

Deceleration Force: $G = \frac{2V_o^2 + 2V_oV_f - 4V_f^2}{96.6S}$

Pulse Duration: $t = \frac{2(V_o - V_f)}{32.2G}$

Case C — Increasing and Decreasing Deceleration

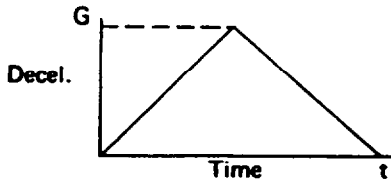

$$\text{Deceleration Force: } G = \frac{V_o^2 - V_f^2}{32.2S}$$

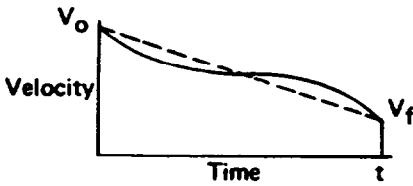

$$\text{Pulse Duration: } t = \frac{2(V_o - V_f)}{32.2 G}$$

III. Half-sine Pulse — Constantly Changing Rate of Deceleration

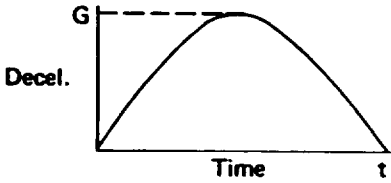

$$\text{Deceleration Force: } G = \frac{.7854 (V_o^2 - V_f^2)}{32.2S}$$

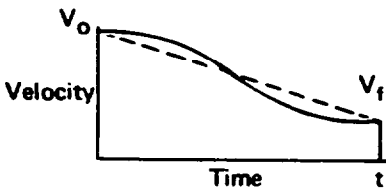

$$\text{Pulse Duration: } t = \frac{1.57 (V_o - V_f)}{32.2 G}$$

(from Crash Survival Investigators' School, 1976).

APPENDIX 24-C

SAMPLE CALCULATIONS OF LANDING AND CRASH FORCES

Example 1: Crash Deceleration Force

A T-28 crashes into a hillside in stalled configuration. The Board establishes through witnesses and wreckage examination that the plane crashed into a 10° incline at 66 mph, wings level, 5° pitch-up attitude (relative to the horizon), digging a 40-foot trench in the earth, 18 in. deep. There was 6 in. of vertical compression to the bottom of the fuselage. The final flight path angle was 15° . The actual impact angle was 25° . Find G-forces relative to the aircraft floor. Consider the deceleration pulse to be triangular (increasing and decreasing deceleration) and final velocity equal to zero ($V_f = 0$).

Step 1. Express all dimensions in appropriate units.

- = Approach speed = 66 mph. x 1.46 = 96.36 fps
- = Stopping distance on the hill = 40 ft.
- = Stopping distance perpendicular to the hill
- = Depth of trench and vertical compression of fuselage
- = 18 in. + 6 in. = 2 ft.

Step 2. Diagram the situation.

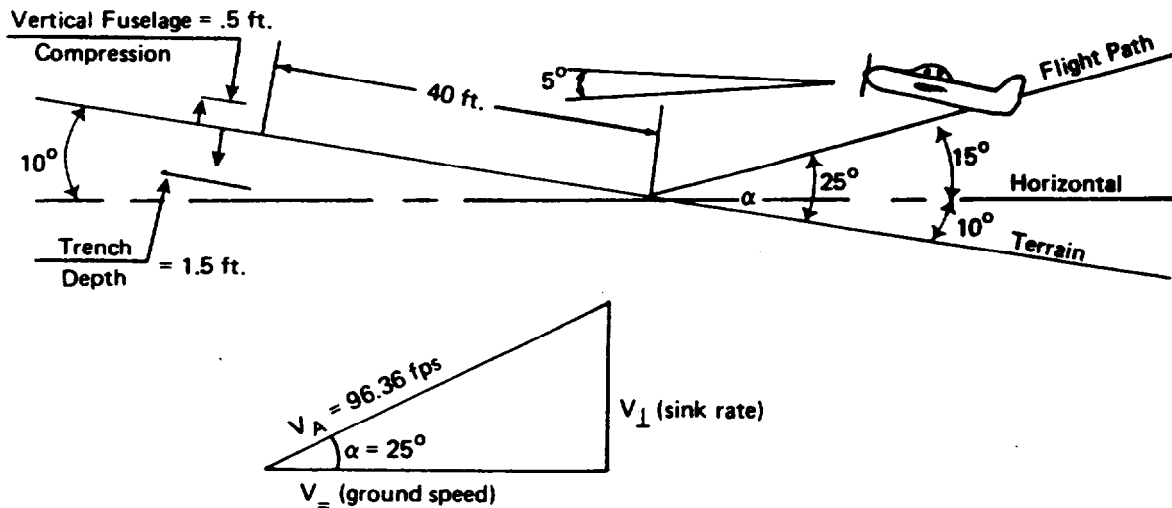

Step 3. Calculations.

a) Sink rate, V_{\perp}

$$\sin 25^{\circ} = \frac{V_{\perp}}{V_A} = \frac{V_{\perp}}{96.36 \text{ fps}}$$

$$\sin 25^{\circ} = .423 \quad \text{(from Appendix 24-A)}$$

$$.423 = \frac{V_{\perp}}{96.36 \text{ fps}}$$

$$V_{\perp} = 40.8 \text{ fps}$$

b) Ground speed, V_{\parallel}

$$\cos 25^{\circ} = \frac{V_{\parallel}}{V_A} = \frac{V_{\parallel}}{96.36 \text{ fps}}$$

$$\cos 25^{\circ} = .906 \quad \text{(from Appendix 24-A)}$$

$$.906 = \frac{V_{\parallel}}{96.36 \text{ fps}}$$

$$V_{\parallel} = 87.3 \text{ fps}$$

c) Component of the G-force perpendicular to the hill, G_{\perp} , for a triangular pulse, Δ , $V_f = 0$

$$G_{\perp} = \frac{V_{\perp}^2}{32.2 S_{\perp}} \quad \text{(from Appendix 24-B)}$$

$$G_{\perp} = \frac{(40.8 \text{ fps})^2}{32.2 \times 2 \text{ ft.}}$$

$$G_{\perp} = 25.9 \text{ G}$$

d) Component of the G-force parallel to the hill, G_{\parallel}

$$G_{\parallel} = \frac{V_{\parallel}^2}{32.2 S_{\parallel}}$$

Aircraft Accident Survivability

$$G_z = \frac{(87.3 \text{ fps})^2}{32.2 \times 40 \text{ ft.}}$$

$$G_z = 5.9 G$$

e) Resultant G-force, G_r , relative to the hill

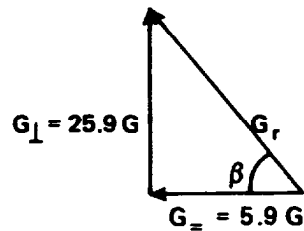

$$G_r^2 = G_z^2 + G_{\perp}^2 = (5.9)^2 + (25.9)^2$$

$$G_r = \sqrt{34.81 + 670.81}$$

$$G_r = 26.56 G$$

$$\sin \beta = \frac{G_{\perp}}{G_r} = \frac{25.9}{26.56} = .975$$

$$\sin^{-1} .975 = 77^{\circ} \quad (\text{from Appendix 24-A})$$

f) G-forces relative to the aircraft floor, G_{za} and $G_{\perp a}$. Since the aircraft approached with a 5° pitch-up attitude, the G-force relative to the aircraft floor is at an angle 5° smaller than the angle of the G-forces to the hillside. This becomes apparent from the following diagram.

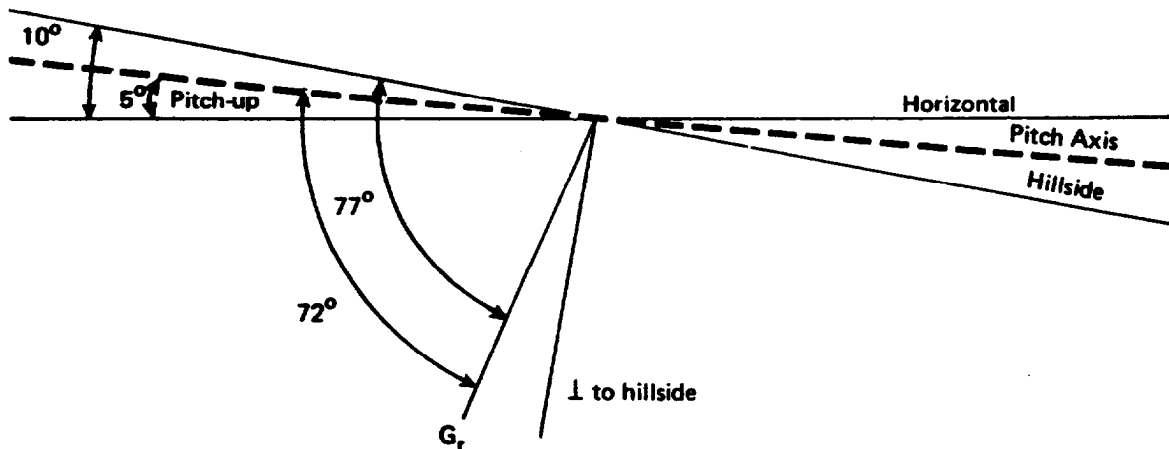

G_r to the aircraft floor is at 72° .

To solve for $G_{\parallel a}$ and $G_{\perp a}$

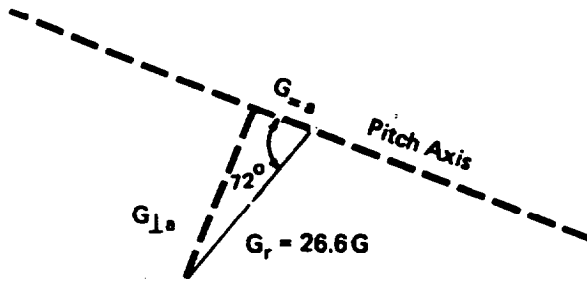

$$\sin 72^\circ = \frac{G_{\perp a}}{G_r} = \frac{G_{\perp a}}{26.6 G}$$

$$\sin 72^\circ = .951$$

(from Appendix 24-A)

$$.951 = \frac{G_{\perp a}}{26.6 G}$$

$$G_{\perp a} = 25.3 G$$

$$\cos 72^\circ = \frac{G_{\parallel a}}{G_r} = \frac{G_{\parallel a}}{26.6 G}$$

$$\cos 72^\circ = .309$$

(from Appendix 24-A)

$$.309 = \frac{G_{\parallel a}}{26.6 G}$$

$$G_{\parallel a} = 8.2 G$$

Step 4. Conclusion:

$$G_{\perp a} = 25.3 G$$

$$G_{\parallel a} = 8.2 G$$

This was a survivable accident, but it is likely that vertebral column injury was present that could have impeded egress.

Aircraft Accident Survivability

Example 2: Carrier Landing Forces

Using a hypothetical set of conditions, determine the deceleration force during an arrested landing of an F-4 aircraft and the time of exposure to these forces

Indicated Airspeed (I.A.S.)	= 155 kt.
Carrier Speed of Advance (S.O.A.)	= 20 kt.
Wind @ 355° relative	= 10 kt.
Rollout on arrestment, S_H	= 275 ft.
Approach Sink Rate, V_V	= 900 fpm
Oleo strut and tire compression of touchdown, S_V	= 9 in.

Consider the arrestment deceleration pulse to be a half-sine pulse (a constantly changing rate of deceleration) and the final velocity equal to zero ($V_f = 0$).

Step 1. Express all dimensions in appropriate units.

155 kt. I.A.S. in 10 kt. wind = 145 kt. ground speed

145 kt. ground speed in approach to a carrier with S.O.A. 20 kts. = 125 kt. ground speed

$V_G =$ Ground speed = 125 kts. x 1.69 = 211.3 fps

$V_V =$ Sink rate = 900 fpm ÷ 60 sec./min. = 15 fps

Because of the sink rate, there is a slight difference between the ground speed and the actual approach speed of the aircraft. The approach speed can be calculated as follows:

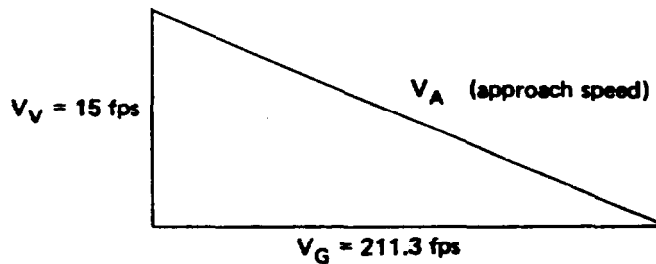

$$V_G = \sqrt{V_V^2 + V_G^2} = 211.8 \text{ fps}$$

$V_A =$ Approach speed = 211.8 fps

$S_V =$ Oleo strut and tire compression = 9 in. = .75 ft.

Step 2. Diagram the situation.

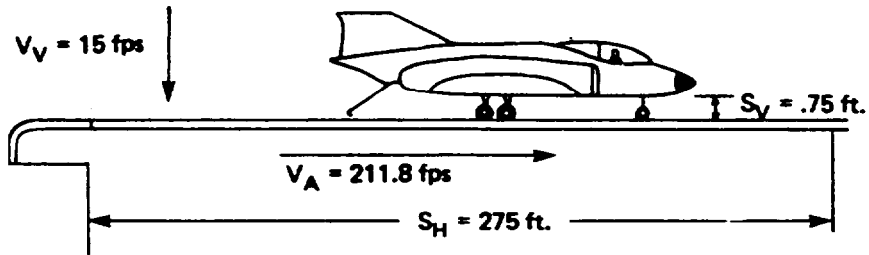

Step 3. Calculations.

a) Horizontal component of the G-force, G_H , for a half-sine pulse, $V_f = 0$

$$G_H = \frac{0.7854 V_A^2}{32.2 S_H} \quad \text{(from Appendix 24-B)}$$

$$G_H = \frac{0.7854 (211.8 \text{ fps})^2}{32.2 \times 275 \text{ ft.}}$$

$$G_H = 4 G$$

b) Duration of G_H , time G_H

$$\text{time } G_H = \frac{1.57 V_A}{32.2 G_H} \quad \text{(from Appendix 24-B)}$$

$$\text{time } G_H = \frac{1.57 (211.8 \text{ fps})}{32.2 \times 4 G}$$

$$\text{time } G_H = 2.6 \text{ sec.}$$

Aircraft Accident Survivability

c) Vertical component of the G-force, G_V , for a half-sine pulse, $V_f = 0$

$$G_V = \frac{0.7854 V_V^2}{32.2 S_V} \quad \text{(from Appendix 24-B)}$$

$$G_V = \frac{0.7854 (15 \text{ fps})^2}{32.2 \times .75 \text{ ft.}}$$

$$G_V = 7.3 G$$

d) Duration of G_V , time G_V

$$\text{time } G_V = \frac{1.57 V_A}{32.2 G_V} \quad \text{(from Appendix 24-B)}$$

$$\text{time } G_V = \frac{1.57 (211.8 \text{ fps})}{32.2 \times 7.3 G}$$

$$\text{time } G_V = 1.4 \text{ sec.}$$

e) Resultant G-force, G_R , when touchdown and arrestment occur simultaneously.

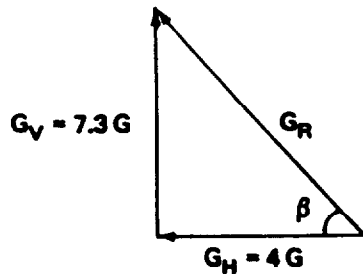

$$G_R^2 = G_V^2 + G_H^2 = (7.3 G)^2 + (4 G)^2$$

$$G_R = \sqrt{53.29 + 16}$$

$$G_R = 8.3 G$$

$$\tan \beta = \frac{G_V}{G_H} = \frac{7.3G}{4G} = 1.825$$

$$\tan^{-1} 1.825 = 61.3^\circ$$

(from Appendix 24-A)

$$G_R = 8.3G \text{ at } 61.3^\circ$$

Step 4. Conclusion.

$$G_H = 4G \text{ for } 2.6 \text{ sec.}$$

$$G_V = 7.3G \text{ for } 1.4 \text{ sec.}$$

$$G_R = 8.3G \text{ at } 61.3^\circ$$

These forces are, of course, survivable.

Example 3: Multiple Deceleration Forces

A T-34 with simulated engine failure attempts wave-off at 500 ft., but the engine fails and the aircraft continues an unpowered descent. The Aircraft Mishap Board reconstructs the following sequence. The left wing snapped off a 9-inch-thick pine tree while crunching the wing to a depth of 3 feet. Airspeed before impact was 105 kt. The aircraft continued airborne at 85 kt. before the right wing passed through and bent a 6-inch pine, putting a 2-foot-deep crunch into its leading edge. Airspeed after the second impact was 60 kt., and the aircraft arced gently to final impact in a swamp. The plane imbedded itself 8 feet into the muddy bottom which was covered by 3 feet of water. Wreckage examination showed the engine to have been displaced 4 feet aft on final impact. Board members and consultants agreed that deceleration forces for each of the three impacts were:

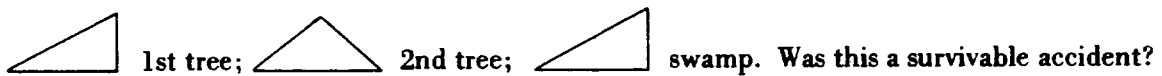

Step 1. Express all dimensions in appropriate units.

$$V_{A1} = \text{Airspeed before impact with tree 1} = 105 \text{ kt.} \times 1.69 = 177.5 \text{ fps}$$

$$V_{A2} = \text{Airspeed before impact with tree 2} = 85 \text{ kt.} \times 1.69 = 143.7 \text{ fps}$$

$$V_{A3} = \text{Airspeed before impact in swamp} = 60 \text{ kt.} \times 1.69 = 101.4 \text{ fps}$$

$$S_1 = \text{Stopping distance at the first tree} = \text{tree diameter} + \text{wing crunch} = 9 \text{ in.} + 3 \text{ ft.} = 3.75 \text{ ft.}$$

$$S_2 = \text{Stopping distance at the second tree} = \text{tree diameter} + \text{wing crunch} = 6 \text{ in.} + 2 \text{ ft.} = 2.5 \text{ ft.}$$

$$S_3 = \text{Stopping distance in swamp} = \text{mud depth} + \text{water depth} + \text{engine displacement} \\ = 8 \text{ ft.} + 3 \text{ ft.} + 4 \text{ ft.} = 15 \text{ ft.}$$

Step 2. Diagram the situation.

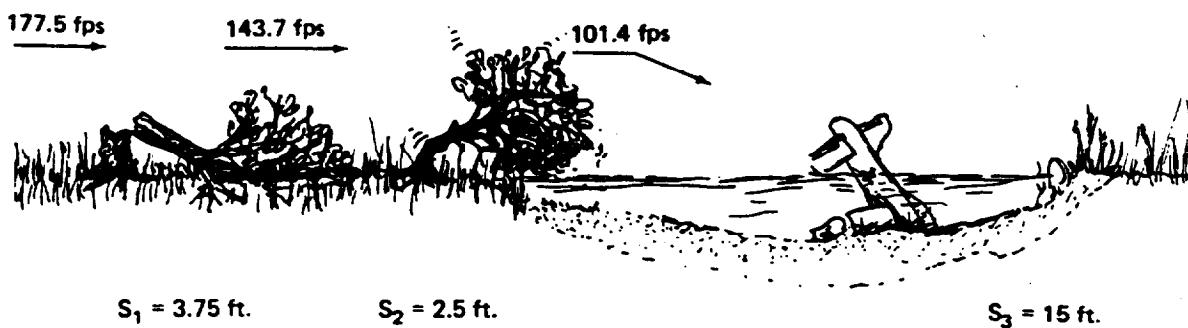

Step 3. Calculations.

a) G-force in impact with tree 1, G_1 , for a triangular pulse, , $V_f \neq 0$.

$$G_1 = \frac{4V_{A1}^2 - 2V_{A1}V_{A2} - 2V_{A2}^2}{96.6 S_1} \quad (\text{from Appendix 24-B})$$

$$G_1 = \frac{4(177.5 \text{ fps})^2 - 2(177.5 \text{ fps})(143.7 \text{ fps}) - 2(143.7 \text{ fps})^2}{96.6 \times 3.75 \text{ ft.}}$$

$$G_1 = 93.1 G$$

b) G-force in impact with tree 2, G_2 , for a triangular pulse, , $V_f \neq 0$.

$$G_2 = \frac{V_{A2}^2 - V_{A3}^2}{32.2 S_2} \quad (\text{from Appendix 24-B})$$

$$G_2 = \frac{(143.7 \text{ fps})^2 - (101.4 \text{ fps})^2}{32.2 \times 2.5 \text{ ft.}}$$

$$G_2 = 128.8 G$$

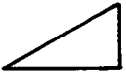
c) G-force in impact in the swamp, G_3 , for a triangular pulse, , $V_f = 0$.

$$G_3 = \frac{4V_{A3}^2}{96.6 S_3} \quad (\text{from Appendix 24-B})$$

Aircraft Accident Survivability

$$G_3 = \frac{4 (101.4 \text{ fps})^2}{96.6 \times 15 \text{ ft.}}$$

$$G_3 = 28.4 \text{ G}$$

Step 4. Conclusion.

$$G_1 = 93.1 \text{ G}$$

$$G_2 = 128.8 \text{ G}$$

$$G_3 = 28.4 \text{ G}$$

This was not a survivable accident. Impacts in the $-G_x$ direction occurring simultaneously with each tree strike exceed the survivability limits given in Table 25-1 by a substantial margin: both crewmen would have perished upon hitting the first tree. To emphasize the importance of velocity, re-do the problem if the exit speed from the first tree was 100 kts. instead of 85 kts. The force associated with the first impact drops from 93.1 G to a survivable 24.6 G, however, the impact with the second tree would then be 227.1 G, which is not survivable.

Example 4: Carrier Ramp Strike

An A-7 making a carrier landing approach gets low in the groove and strikes the ramp without a sink rate. I.A.S. in the approach was 130 kt. to a carrier steaming at 25 kt. into a 5 kt. wind. The Accident Board established that the ramp strike put a 6-foot-deep crunch into the underside of the aircraft as it hit nose high. The relatively intact fuselage without landing gear slid up the deck decelerating from 90 kt. at the beginning of the slide to 75 kt. as it passed over the angle after 600 feet of travel. The aircraft came to rest in the water after an estimated 300 feet of airborne trajectory from a deck height of 75 feet and 60 feet of travel through the water. Ascertain if the impact forces involved were survivable because the pilot was not recovered.

Step 1. Express all dimensions in appropriate units.

- 130 kt. I.A.S. in 5 kt. wind = 125 kt. ground speed**
- 125 kt. ground speed in approach to a carrier with S.O.A. 25 kt. = 100 kt. landing speed**
- V_O = Landing speed = 100 kt. x 1.69 = 169 fps**
- V_D = Speed crossing the deck = 90 kt. x 1.69 = 152.1 fps**
- V_A = Speed passing over the angle = 75 kt. x 1.69 = 126.8 fps**
- V_f = 0 (aircraft resting in water)**
- S_R = Stopping Distance at ramp impact = aircraft crunch = 3 ft.**
- S_D = Distance traveled on the deck = 600 ft.**
- S_W = Stopping Distance in the water = 60 ft.**

Step 2. Diagram the situation.

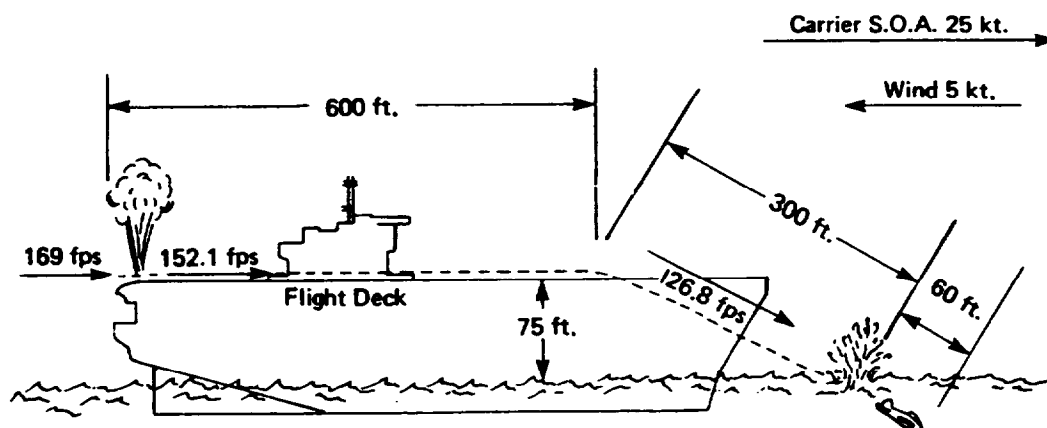

Aircraft Accident Survivability

Step 3. Calculations.

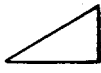
a) G-force in ramp impact, G_R . Assume a triangular pulse  , $V_f \neq 0$.

$$G_R = \frac{4V_0^2 - 2V_0V_D - 2V_D^2}{96.6 S_R} \quad \text{(from Appendix 24-B)}$$

$$G_R = \frac{4(169 \text{ fps})^2 - 2(169 \text{ fps})(152.1 \text{ fps}) - 2(152.1 \text{ fps})^2}{96.6 \times 3 \text{ ft.}}$$

$$G_R = 57.2 G$$

b) Duration of G_R , time G_R

$$\text{time } G_R = \frac{2(V_0 - V_D)}{32.2 G_R} \quad \text{(from Appendix 24-B)}$$

$$\text{time } G_R = \frac{2(169 \text{ fps} - 152.1 \text{ fps})}{32.2 \times 57.2 G}$$

$$\text{time } G_R = .02 \text{ sec.}$$

c) G-force in slide over the deck, G_D . Assume a rectangular pulse  , $V_f \neq 0$.

$$G_D = \frac{V_D^2 - V_A^2}{64.4 S_D} \quad \text{(from Appendix 24-B)}$$

$$G_D = \frac{(152.1 \text{ fps})^2 - (126.8 \text{ fps})^2}{64.4 \times 600 \text{ ft.}}$$

$$G_D = 0.2 G$$

d) Duration of G_D , time G_D

$$\text{time } G_D = \frac{V_D - V_A}{32.2 G_D} \quad (\text{from Appendix 24-B})$$

$$\text{time } G_D = \frac{152.1 \text{ fps} - 126.8 \text{ fps}}{32.2 \times 0.2 G}$$

$$\text{time } G_D = 4 \text{ sec.}$$

e) G-force in water entry, G_W . Assume a triangular pulse.  , $V_f = 0$.

$$G_W = \frac{4 V_A^2}{96.6 S_W} \quad (\text{from Appendix 24-B})$$

$$G_W = \frac{4 (126.8 \text{ fps})^2}{96.6 \times 60 \text{ ft.}}$$

$$G_W = 11.1 G$$

f) Duration of G_W , time G_W

$$\text{time } G_W = \frac{2 V_A}{32.2 G_W} \quad (\text{from Appendix 24-B})$$

$$\text{time } G_W = \frac{2 (126.8 \text{ fps})}{32.2 \times 11.1 G}$$

$$\text{time } G_W = 0.71 \text{ sec.}$$

Aircraft Accident Survivability

Step 4. Conclusion.

$$G_R = 57.2G \text{ for } 0.02 \text{ sec.}$$

$$G_D = 0.2G \text{ for } 4 \text{ sec.}$$

$$G_W = 11.1G \text{ for } 0.71 \text{ sec.}$$

The impact forces incurred at the initial ramp strike were probably not survivable. The amount of crunch to the aircraft is a critical figure. If the Board decided that the crunch was 6 ft., that figure at the ramp would change from an unsurvivable 57.2 G to a survivable 28.6 G, and more crunch would attenuate even more of the forces. Accurate Board input for the calculations is critical.

In the most technical sense, calculation of the water impact forces should be via trigonometric functions, setting up a triangle based on known distances, figuring the water entry angle, and substituting velocities in the same triangle for final G calculation.

a) Calculation of the water impact angle

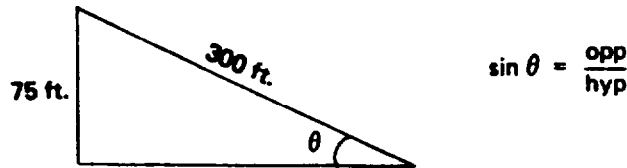

$$\sin \theta = \frac{75}{300} = .25$$

(from Appendix 24-A)

$$\sin^{-1} .25 = 14.5^\circ$$

b) Calculation of the sink rate, X

$$\text{sink rate} = V_x$$

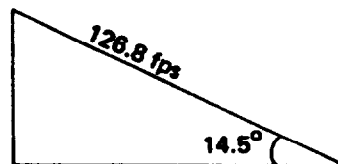

$$\frac{V_x}{126.8 \text{ fps}} = (\sin 14.5^\circ) = .25$$

$$V_x = 31.7 \text{ fps sink rate}$$

c) Calculation of the vertical component, G_V , for the water impact

$$G_V = \frac{4V_x^2}{96.6S_w}$$

(from Appendix 24-B)

$$G_V = \frac{4(31.7 \text{ fps})^2}{96.6 \times 60 \text{ ft.}}$$

$$G_V = 0.7G$$

d) Calculation of the horizontal component, G_H , for the water impact

$$G_H = \frac{4V_A^2}{96.6 S_w}$$

(from Appendix 24-B)

$$G_H = \frac{4(126.8 \text{ fps})^2}{96.6 \times 60 \text{ ft.}}$$

$$G_H = 11.1G$$

e) Calculation of the resultant G , G_R , for the water impact

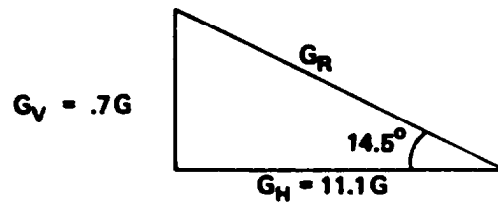

Aircraft Accident Survivability

Using $a^2 + b^2 = c^2$

$$G_R^2 = (11.1)^2 + (.7)^2$$

$$G_R = 11.12G \text{ at } 14.5^\circ$$

This calculation confirms that for such shallow angles of water entry, the trigonometric approach involves extra work for the same answer.

CHAPTER 25

AIRCRAFT ACCIDENT AUTOPSIES

Introduction
Administrative Considerations
Field Procedures
Autopsy
Accident Causation
Role of the Flight Surgeon
References and Bibliography

Introduction

As the Navy continuously attempts to develop effective programs to prevent accidents and to protect aircrewmembers, program designers frequently turn to available medical data to find correct solutions, only to be frustrated by the realization that much of the relevant data are not observed and not recorded. Those attempting to design better support and survival equipment, such as helmets, life preservers, and escape systems, often ask specific and important questions about the pathogenesis of injury and the precise mechanisms of death. Far too often, these questions remain unanswered. The objective of this chapter is to examine aviation accident autopsy procedures in a manner which will suggest to the flight surgeon and to the pathologist alike potentially rewarding avenues for solutions to these important problems. This chapter does not repeat the technical and professional information currently available to pathologists concerning the performance and interpretation of a postmortem examination. The intent is to dwell only on those facets of the problem which tend to be peculiar to the aviation accident autopsy.

Aviation accident pathology is defined by Mason (1962) as "the application of methods and techniques of pathology to the comprehensive understanding of aircraft accident causes and genesis." To achieve a comprehensive understanding of such an event requires that thoroughly studied autopsy material be analyzed and interpreted in the context of well-defined operation and environmental considerations. Combining these two types of information should lead to a correct explanation of the etiology of the accident event. Although this is seldom accomplished in routine investigations, the validity of this method remains unchallenged.

The successful mishap investigation requires autopsies of the mission, the aircraft, and the victims. Over 80 percent of the fatal mishaps are attributed to human factors as causal or contributory. This statistic has not changed despite generations of change in aircraft design, avionics, egress systems, and personal equipment. The role of the flight surgeon in integrating the pathology or hospital reports, 72-hour history, witness statements, medical and dental records and the scene investigation cannot be overemphasized in his importance to the Mishap Investigation Board.

Administrative Considerations

Because many Navy aircraft accidents occur in civilian jurisdictions, it is necessary to understand the requirements of state and federal investigators.

Custom, usage, and the law have defined the state as the appropriate government unit to deal with decedents' affairs. State officials must derive information needed to establish the cause and manner of death, the identity of the decedent, the presence or absence of foul play, and the requirements for administering estates, wills, and insurance payments. The Federal Government, on the other hand, is obliged to regulate air traffic, define safety standards in aviation, operate public aircraft safely and efficiently, study accident causes to prevent recurrence, and maintain the security of federal property. If one compares the requirements outlined above, which are necessarily incomplete, it becomes obvious that the differences should logically result in different methods and goals for the conduct of an aviation autopsy, depending on whether it is intended to satisfy state or federal purposes. It is important for a flight surgeon to understand that the different requirements placed on the local coroner mean that his examination, in all likelihood, will not address those issues posed by the Navy in its safety investigation.

An excellent example of the dissimilarity between state and federal purposes is found in a state law which requires that "The coroner shall hold an inquest upon the dead bodies of such persons only as are supposed to have died by unlawful means." Such a law, administered even by the most sympathetic and careful state official, would reasonably be interpreted to preclude postmortem examination of aircraft accident victims based on the presumption that such events generally are not caused by unlawful means.

The most practical way to manage investigation problems on civilian terrain is to begin by consulting the local legal officer representing the naval district or the supporting naval air station. Informal contacts with physicians in the civil community, which may include the local coroner or medical examiner and the local pathologist, may provide obvious solutions and courses of action. The current OPNAVINST 3750.6 establishes that a naval activity's premishap plan must include

Aircraft Accident Autopsies

arrangements for ensuring the immediate retrieval of remains. These considerations are commonly overlooked and are a frequent source for delay, confusion, and acrimony which can interfere with effective study of a case.

Aircraft Accident Autopsies

There is a statutory basis for federal authority to conduct autopsies. In Chapter 20, Title 49, U.S. Code, Section 701, there is a provision for the National Transportation Safety Board “to examine the remains of any deceased person aboard the aircraft at the time of the accident who dies as a result of the accident and to conduct autopsies or such other tests thereof as may be necessary to the investigation of the accident; provided, that to the extent consistent with the needs of the accident investigation, provisions of local law protecting religious beliefs with respect to autopsies shall be observed.”

The Armed Forces Joint Committee on Aviation Pathology has proposed a change to the U.S. Code which would provide the authority for military departments to examine the remains of any deceased person aboard an aircraft at the time of an accident and to conduct autopsies or such other tests as might be necessary to investigate the accident. It is possible that definite developments in the law may take place within the next few years. Until that time, the best working remedy is to anticipate local jurisdictional problems and to plan coordinated efforts with the involved officials to satisfy the needs of both the state government and the Navy. Frequently, a copy of the autopsy protocol, delivered to the appropriate state official, is adequate to allow the retrieval and examination of remains in a civilian jurisdiction.

For accidents occurring on federal reservations in which there is exclusive federal jurisdiction, BUMEDINST 6510 series, Article 17-2, *Manual of the Medical Department*, and Paragraph 703 of OPNAVINST 3750.6 define the authority to perform autopsies on military occupants fatally injured in aircraft accidents. The Decedent Affairs Manual, BUMED 5360 series and the BUMED 6320 series, may also be useful guides.

In addition to concurrent and exclusive jurisdiction described above; within CONUS, two additional legal instruments may be in play, attorney general's opinions and writs of Mandamus. The latter are court orders requiring an official with a defined responsibility to carry out that responsibility. An article appearing in the *Journal of Forensic Sciences* by J.D. Spencer entitled “Medical Examiner/Coroner Jurisdiction in Cases Involving Federal Interests” addresses these issues and is an excellent source for current legal concepts.

Medicolegal death investigations overseas are potentially more difficult to control. Deaths aboard ship, regardless of nationality, come under the jurisdiction of the government of the ship's port of entry. In NATO countries having a status of forces agreement with the United

States, provision is usually made for U.S. servicemen to be handled by local U.S. military installations. However, it is well worth the effort to ensure complete understanding of the local rules and to establish appropriate communication with the authorities prior to entering the port.

Field Procedures

Procedures to be followed by a flight surgeon as a member of an accident investigation team are described in Chapter 23, *Aircraft Mishap Investigations*. This covers the requirements imposed on the flight surgeon. The immediate collection of information at the crash site which can be used to support the later postmortem examination is essential.

The biggest problem to be faced by a flight surgeon in the first few hours following a crash is one of documenting the relationships at the crash scene before the body is moved. There is an initial, and very understandable, emotional response by the first individuals on the crash scene to do something about the body. It is quite difficult for most individuals to begin any kind of systematic examination of crash issues while the deceased pilot remains in the cockpit. Characteristically, the body is removed from the cockpit and taken to some other location before the investigation has any organization at all. Frequently, it is a day later before the principal accident investigators arrive, and, by this time, much of the information to be gleaned from the pilot's remains has been lost. Such losses include the location and spatial relationship of the remains to the aircraft structure or systems components, prominent terrain features, and areas of fire. Therefore, to the extent feasible, a flight surgeon should attempt to document the relationships at the scene before the body is moved. Sketches, photographs, and a careful examination of the aircraft with the body untouched can prove invaluable in supporting evidence found later during autopsy procedures. Of particular import here is documentation of the mechanics at the scene that could explain injury. For example, a diagram which shows the location of the body, of various components of the aircraft, and of a postimpact fire can help later in differentiating burns which occurred after the accident from those which might have occurred in the cockpit prior to the crash. Aerial photographs usually are of value in showing spatial relationships, aircraft parts, thermal damage, fuel spills. etc.

Film is the cheapest commodity in the mishap investigation. Utilization of base photographers early in the investigation substantially reduces the possibility of lost evidence. Videotaping the scene prior to body removal is a practice gaining in usage in criminal investigations. If the resources are available, consideration should be given to applying this technology to aircraft mishap investigations as well.

Autopsy

A postmortem examination of the victim of an aircraft accident should follow an orderly and well-organized plan. If the most meaningful results are to be obtained, autopsy procedures and techniques should be developed and reviewed, well in advance of their actual use. The flight surgeon should have knowledge of pathology techniques which are usually capable of answering questions posed by the Aircraft Mishap Board (AMB). He should be aware of the types of aircraft operated by the local commands and their assigned missions, the facilities and consultants available from local, federal, and civilian sources, such as crime laboratories, research units, etc., the requirements of applicable state and federal laws and agreements, and the requirements for graphic documentation to allow later interpretation of autopsy findings as new accident findings become available. The Armed Forces Institute of Pathology in Washington, D.C. provides, on request, a medical investigation team to assist the flight surgeon on-site. The team is composed of flight surgeon-forensic pathologists and a photographer.

The direction of the pathology inquiry may be guided by three principal objectives. There are (1) diagnosis of preexisting disease conditions, (2) the description of all injuries and an analysis of their pathogenesis, and (3) cataloging of all observations which might serve to better understand the accident cause and sequence. Examples of these considerations are included below.

Identification

Identification of remains is usually accomplished in naval aircraft accidents with relative ease because the number of aircraft occupants is usually small, the available operational data concerning the aircraft and its occupants are abundant, and dental records are characteristically available and accurate. It should be noted, however, that reliable identification of remains is essential to correlation of autopsy findings with accident cause and sequence. Even when the intent is to autopsy crew members only, medical examinations of all remains may be required to establish which subjects are in fact crew members. Details of these techniques are described by Spitz and Fisher (1973).

The identification process, however, is frequently underestimated in importance and man-hours. Large numbers of casualties are logistical nightmares. There are two main categories of identification, positive and presumptive. Positive identification includes those methodologies separating an individual from all others. These include dental comparisons, fingerprints, palm prints, foot prints, and certain radiological studies such as frontal sinuses and lumbar spines when premortem examples are available. Presumptive identification includes visual identifications, anthropometric data, serological evidence, personal effects, evidence of medical therapy, the flight

manifest, etc. This type of evidence separates a subpopulation from the total population rather than an individual from the population. Identifications by exclusion can only be made when all casualties have been accounted for.

Preexisting Disease

The search for preexisting disease conditions is a routine part of any autopsy examination. However, in an aviation mishap, it warrants increased attention. Here the objective is not just to describe the health condition of the deceased, but to search for conditions which might have caused incapacitation in flight or which might have led to a reduction in sensory or motor capacities. Only three systems can cause immediate incapacitation: the central nervous system, the respiratory system, and the cardiovascular system. Biliary colic, renal lithiasis, diarrhea, and infections are important contributory factors, their presence often requires diligent searching.

In looking for preexisting diseases, one of the classic questions is "What role did ischemic heart disease play in postulated pilot incapacity?" Because coronary artery disease is so common, there frequently will be some description in an autopsy protocol concerning coronary atherosclerosis. The objective is to specify the extent of coronary occlusion and its morphological consequences and to indicate the likelihood that this might have resulted in either transient or permanent pathophysiological states.

It is not reliable or useful to define a coronary lesion independently of a comprehensive analysis of the operational circumstances. Such a "clinical history" frequently provides evidence that clearly precludes the etiological relationship of established lesions. For example, a scenario in which the pilot of a troubled aircraft describes by radio the detailed progression of mechanical difficulties which preclude both continued flight and safe egress, makes it untenable that the accident was caused by sudden incapacitation, even in the presence of the most impressive morbid anatomy. Furthermore, it is useful to remember that a flight might be completed and indeed many have been completed, without accident, even when the pilot was incapacitated. The differential diagnosis of the aberrant behavior related to an accident logically includes psychological and physiological considerations as well as organic disease. These are easily overlooked or misinterpreted by pathologists who do not have experience in aviation. Often a psychological autopsy is necessary to characterize potential behavioral factors.

Description of Injuries

All injuries sustained during the accident should be described in detail. This is true whether or not a specific injury might have contributed to the death of the subject. Obviously, the first order

Aircraft Accident Autopsies

of business is to describe those injuries which could have been fatal. It is most important to identify, with as much certainty as possible, the exact cause of death. However, it also is quite important to note all other injuries so that realistic assessments can be made of the safety design of the aircraft and of the effectiveness of specific items of protective equipment.

Flight Surgeon's Reports (FSR) frequently do not provide an adequate characterization of injuries. The FSR may report, for instance, that the pilot suffered a fractured ulna and that the fracture was caused by impact forces. This is sufficiently vague to be essentially meaningless for later use by investigators. It is more helpful to describe and interpret the injury as a transverse fracture of the ulna at a specific location mediated through blunt forces applied to the anterior aspect of the forearm. This can then be correlated to specific cockpit structures adjacent to the arm of the pilot, as he was observed in the cockpit following the impact. In short, the description of injuries must be as detailed as can reasonably be done and should include any observations and interpretations concerning the likely pathogenesis of the injuries. Diagrams and photographs should supplement written statements.

Full body radiographs with special emphasis on the head, neck and extremities are extremely useful in the clarification of injury mechanisms, particularly when correlated with photographs and diagrams.

There are also patterns of injuries which may serve to define events and injury mechanisms. Knowledge of these patterns can be useful to a flight surgeon as he interprets and assists in the autopsy examination. For example, bilateral subconjunctival hemorrhage in the absence of other ocular injuries characteristically suggests premortem negative acceleration in the z-axis (-Gz). These patterns are best recognized when there is adequate documentation and timely discussion between the board flight surgeon and pathologist.

Distribution of Injuries

Certain injuries tend to occur frequently in aircraft accidents, simply because of the nature of the force environment and mechanisms found in such events. A flight surgeon should understand this distribution, but he should also recognize that the characteristics of these injuries may change as aviation missions change and as one deals with different types of aircraft. Unusual injuries representing a deviation from the expected may signal a previously unrecognized pathogenic mechanism or a peculiar event important to an understanding of the accident sequence. To monitor such events, the Naval Safety Center analyzes all aviation accident injuries as functions of anatomic site involved and aircraft type. This provides a means of comparing injuries that occur in one aircraft type with injuries occurring in a different type. Differences in injury patterns

may also be compared with the averaged injury tabulation for all types of aircraft. Significant differences invite attention to systematic failures that predispose to the subject injury.

In a similar manner, it is possible to tabulate the kinds of injury reported and to identify the proportions of the total injury experience contributed by each diagnostic category (Table 25-1). The data tend to reflect injuries that are of major significance and readily and conclusively identifiable, but they do not consistently relate to the cause and mechanism of death.

Table 25-1

Distribution of Navy and Marine Corps Aviation Accident

Injuries by Diagnostic Categories

Diagnosis	Percent of Total Injuries Reported
Fracture/Dislocation	22.8
Contusion	16.1
Laceration	12.3
Abrasion	8.3
Thermal Burn	7.9
Sprain/Strain	7.6
Multiple Extreme Injuries	6.3
Amputation/Avulsion	3.6
Hemorrhage	2.4
Perforation/Rupture	2.1
Concussion	1.1
Crushing	1.1
Decapitation	1.1
Miscellaneous	7.3

Head and Neck Injury

The evaluation of head and neck injury is an area of particular concern and obvious importance during an autopsy examination. The head and neck area is especially susceptible to injury from the forces of an aircraft accident, and the nature of head injuries is such that acute incapacity and fatal consequences can be anticipated. Twenty-four percent of all injuries affect the head and neck, even though their surface area and mass represent a lesser proportion of the body. A

Aircraft Accident Autopsies

truly random distribution of injuries is not likely in an aircraft accident. Cockpit and cabin structural configuration, methods of restraint, common patterns of accident acceleration, and the nature of protective devices influence this injury distribution. The design of such devices, including protective helmets, can logically derive from detailed observations of pathogenetic mechanisms of head and neck injury. The aviation accident experience is the medium through which one may make unique and valuable assessments of such mechanisms.

The use of Flight Surgeon's Reports to answer the question, "What is the nature of the head injury, and how did it occur?" is limited to the quality of the data. Frequently, the FSR contains a description of helmet condition, a notation that the skull was fractured or that there were lacerations over portions of the head, and that the head injury was due to impact. Information such as this is not sufficiently detailed to be useful. One needs more information about the sequence of accident events, a better definition of the applied forces, and some indication of the order of magnitude of accident impact forces. Knowledge of the mechanism of injury is vital to most remedial efforts. Frequently, radiographs of the helmet will disclose otherwise missed fractures in the fiberglass which when correlated with the autopsy results will define cranio-cervical injury mechanisms.

Severe injuries can be sustained by the head and the cervical region which are not easily noted on routine examination. For example, a preliminary examination might indicate the cause of death was an impact force applied to the lower thoracic region, resulting in broken ribs, severe visceral lacerations, and extensive hemorrhaging. In fact, however, such injuries might well be survivable, with the actual cause of death being an unnoticed transection or laceration of the spinal cord at the base of the brain. When a number of injuries are sustained at the same time, it is very important to identify those which explain the mechanism of death. A posterior layerwise dissection of the neck must always be done to exclude such cervical trauma.

The correct identification of head and neck injuries provides invaluable data for designers of aviation protective clothing and equipment. At this time, Navy research and development effort is being directed toward the development a new helmet for aircrewmembers. The helmet is to allow better head movement during air-to-air combat and to provide even more protection than afforded by current helmets. Should it be stronger, lighter, fully restrained, or frangible? One of the best ways to answer these questions is with information developed through meticulous autopsy examination in which head and neck injuries are described in detail and carefully related to the crash circumstances. The use of night vision goggles (NVG's) has added greater need for a meticulous neck dissection and adequate radiographic and photographic documentation.

There are four mechanisms for head and neck injury which predominate in aviation accidents.

The autopsy examination should evaluate each of these as a possible cause of death, even though other injuries obviously were sufficient in themselves to be fatal. The following sections describe these mechanisms.

Head-Neck Inertia. When the body is moving at a given velocity and is suddenly decelerated, whether by impact or by ejection and dynamic ram air pressure, there can be an inertia of the head, neck, helmet, mask complex which can cause a severe differential deceleration of this complex with respect to the rest of the body. There may be a flexion so that the head is moved forward or backward suddenly with consequent hyperextension of the neck and either injuries to the bone and muscle around the neck or a pulling of the central nervous axis. In order to demonstrate at autopsy that this has occurred, it is necessary to make a dissection of the central nervous system so that the brain stem, the medulla oblongata, and the cervical spinal cord are not altered in the dissection. That block of anatomy has to be viewed undistorted. A posterior dissection into the spine and occipital skull is recommended to expose the relevant tissues and to determine whether there are lacerations, hemorrhage, or other physical evidence of mechanical trauma at the site.

In the aft-hyperextension case, hemorrhage may be noted in the para-spinal muscle system. With forward hyperflexion or hyperextension, fractures may be noted in the anterior vertebral bodies and in other muscle groups. If the brain stem is maintained intact, gross lacerations of that part of the brain stem or the vessels covering the brain stem may be seen on section. Capillary hemorrhages within the brain stem also may be noted.

Direct Impact. Direct impact injury is found when an aviator's helmet receives a direct blow during an accident. Under circumstances where the impact delivers sufficient energy to separate the helmet and then to disrupt the skull and brain beneath it, the cause of death is obvious. It is then apparent that the energy absorbing qualities of the helmet were exceeded. In such a case, the postmortem examination is largely a matter of documenting the injuries and attempting to estimate the magnitude of the force which caused the helmet to separate. Typical injuries to be noted include epidural, subdural, and subarachnoid hemorrhages, and avulsions, lacerations, and hemorrhage of the brain itself.

Translated Impact. A more elusive, and somewhat speculative, mechanism for head and neck injury can be used to account for cases in which the helmet remains intact, but a fatal injury is sustained nonetheless. In such an instance, the helmet has apparently distributed impact forces uniformly over the skull so as to keep tissue pressure per unit area, and consequent tissue damage, at a minimum. However, the fact that the accident was fatal would indicate that the actual distribution of impact forces did not provide adequate protection.

Aircraft Accident Autopsies

If one conceives of the human skull as being a bit akin to an old Roman arch, or a Roman bridge, a case can be made that impact force is not uniformly distributed but instead is simply translated from one part of the head to another. The engineering principle behind the Roman arch was that force applied at the top was carried by the form of the curved structure to the pillar or base, where it could be supported better than at the top. Within the skull, a similar arch can be identified. It is comprised of the calvarium, the lateral temporal bone, and the petrous ridges of the temporal bone. This curved structure has as its base the part of the skull where the brain stem resides, the posterior part of the body of the sphenoid bone, and the basilar portion of the occipital bone.

A characteristic finding in autopsies with head injuries in which helmets were worn is a fracture occurring just anterior to the petrous ridge of the temporal bone and extending toward the brain stem. Frequently, the base of the skull at the juncture of the posterior and middle compartments becomes almost bivalved, so that one can actually move it as a bivalve structure, indicating the significance and depth of the fracture at the anterior limits of the petrous ridge. A similar lesion is described by Spitz and Fisher (1973) as a hinge fracture. This section of bone is rather thin and apparently is more mechanically susceptible to discontinuity as forces are applied. It appears, then, that when energy is applied to an upper portion of the helmet it may simply be translated through the “arch” of the skull and delivered to the base of the brain, resulting in the fracture frequently seen at the anterior limits of the petrous bone. Energy applied there may become lethal immediately because vital centers for respiration and other autonomic functions are located in the brain stem. Hinge basilar skull fractures such as these have been noted in cases where the victim strikes his mandible on an object with such force as to transfer the force through the mandible to the temporomandibular joint and the skull base.

The situation thus may exist where an autopsy shows a head that is completely intact externally and a helmet which has sustained some damage. The assumption may be made that the helmet was effective as designed because the damage is in the helmet and not in the exterior of the head. However, this may be misleading. The translation of energy, imparted at the helmet and transmitted through the “arch” of the skull, may have consequences in the brain stem which are quite lethal. This is an anomaly which can easily be overlooked during a “routine” postmortem examination.

Hangman's Noose Analogy. The inferior edge of an aviator's helmet, when visualized as part of the continuous circle completed by the nape strap and the chin strap, forms a loop that can be likened to a hangman's noose. The analogy might be further extended to include the lesions made about the neck by the straps or the edge of the helmet, paralleling the abrasions and contusions that might be associated with a rope having encircled the same structures. When the knot is

situated at the side of the head (subdural), such a hangman's noose produces fractures of the base of the skull, tending to extend bitemporally through the basisphenoid. When the knot is situated anteriorly and beneath the chin (submental), the hangman's noose causes a fracture dislocation at the axis (Wood-Jones, 1913). Characteristically, the posterior arch is fractured and, interestingly enough, the odontoid process is not involved.

One interesting and compelling aircraft accident investigated by the Naval Safety Center, Norfolk, Virginia, served to emphasize the practical application of this theoretical exercise (Colangelo, 1974). A Navy A-4 jet aircraft experienced difficulties in flight which caused the pilot to eject at an altitude, attitude, and airspeed that were within the operating envelope of the ejection seat. Supported by a fully blossomed, functioning parachute, however, the pilot reached the ground severely injured and died shortly after the accident as a result of a transverse laceration of the cervical spinal cord.

The investigation established that the energy responsible for the fatal lesion was transmitted through the helmet and its inferior edge into the posterolateral neck. A vertebral dislocation of C-2 and C-3 resulted, which in turn severed the spinal cord. The essential mechanism of injury involved the application of blunt force to one side of the helmet, causing it to rotate about the pilot's head in such a way that the opposite side of the helmet was forced inferiorly and medially into the adjacent neck region. Similar observations had prompted an earlier modification of the helmet to incorporate a thicker protective edge roll. It is often tacitly assumed when a helmet which has been subjected to a large impact force exhibits only slight damage the head which is designed to protect should remain proportionally secure. This unfortunate case illustrates that nothing could be further from the truth.

The pathology itself was distinctive in that a dislocation without fracture occurred at the C-2/C-3 level of the cervical spine. A laminectomy was performed post mortem to expose the spinal cord. Histologic sections made through the C-2/C-3 vertebrae confirmed that no fracture was present, despite common observations in the literature that fracture is the usual, if not an invariable accompaniment, of such severe dislocations (American Academy of Orthopaedic Surgeons Symposium, 1969).

It is especially interesting that "hangman's fracture" has been fairly recently defined as a bilateral avulsion fracture through the neural arch of the axis, with or without fracture dislocation of the second cervical vertebral body from the third (Schneider, Livingston, Cave, & Hamilton, 1965). The concept of the "cervicocranium" as an entity constituted by the cranium, the atlas, and the axis suggests that this functional segment above C-3 tends to move as a single unit, in dislocation as well as in flexion, extension, and rotation. The implied mechanical

weakness at C-3 or the junction of the cervicocranium with the lower cervical spine makes it a likely site for dislocations in injuries sustained by mechanisms resembling that presented in this particular accident.

Other Injuries

Blunt Trauma to the Lungs. Mason (1962) notes that decelerative pulmonary lesions of the severity seen in aircraft accidents should be more akin to blast injuries than to those sustained in motor accidents. When a heavy blunt force is applied to the lungs, there is extensive hemorrhaging, probably as a result of internal shearing forces. Mason review the experimental literature describing specific patterns of hemorrhaging found with deceleration forces. Unfortunately, there is little information available on the pattern of lung damage to be found in aircraft accidents, although damage of this type can be noted in over 50 percent of all fatalities.

An important point in dealing with lung trauma is to be able to separate accident damage from evidence of preexisting lung pathology. As the vasculature is torn during an accident, blood enters pulmonary alveolae, as does serum. The serum in alveolar spaces can resemble edema fluid, thus presented a confusing picture to a pathologist. Whether this fluid is there as a direct result of the accident or as part of an earlier disease process can only be determined by reviewing the location of lacerations in lung tissue, other pathological findings in the cardiorespiratory complex, and the clinical history.

Thoraco-Adominal Trauma. Thoraco-abdominal trauma is frequent and often extensive. Attempts should be made to define restraint and other impact blunt force injuries, decelerative injuries, penetrating and perforating wounds. Such injuries often define the forces applied to the victim as a result of seat and restraint system failures, loss of occupiable space, or cargo shifts.

Extremity Injuries. Extremity injuries while quite evident should always be documented radiographically. Dissections disclosing hemorrhage about the fracture or dislocation often support the contention that the injury is premortem rather than postmortem artifact. The radiographs in addition to documenting the site of injury usually shed light on the mechanism of injury and the direction of applied forces. Such techniques may well define the so-called control surface injuries on the hands and feet of the pilot in command at ground impact. (Coltart, 1952; Krefft, 1970).

Thermal Injuries. Thermal injuries are common and tissue damage extensive. Nonetheless, every case should be autopsied and X-rayed. Evidence of survival during the fire includes the absence of immediately fatal injuries, soot in the airways, pulmonary congestion, and frequently positive toxicology studies such as elevated carboxyhemoglobin saturations.

Water Immersion. Cases involving water immersion and the possibility of drowning or hypothermia often are difficult to evaluate. Drowning is a diagnosis of exclusion. The circumstances surrounding the mishap are critical to proper diagnosis. Similarly, hypothermia can be difficult to diagnose, and core body temperatures, water temperature, length of immersion, type of clothing, and so forth, are all critical issues.

Fragmented Bodies. Fragmented bodies are not uncommon and often create a great deal of difficulty in the identification process, separation of commingled remains, and evaluation of specific injury mechanisms. These cases, however, must be handled like any other. A surprising amount of information can be obtained in such cases despite the destruction.

Accident Causation

The responsibility for assigning causes to an aircraft accident rests with the full Aircraft Mishap board. The flight surgeon and the pathologist with whom he might work are responsible for contributing information which will aid the AMB in arriving at the correct causes. However, it can be of considerable help to the AMB if the flight surgeon includes his speculations regarding causative elements. In general, it can be said that a fine clinical sense and considerable experience are required to differentiate among possible causes that might be suggested by anatomical findings. Nonetheless, any conclusions, however tentative, reached by the flight surgeon should be included as part of this Flight Surgeon's Report.

While speculations concerning accident causes are encouraged, considerable thought should be given to each in order to be certain that the pathological interpretations being discussed are consistent with the circumstances of the accident and findings from other lines of investigation.

Role of the flight surgeon

A flight surgeon has definite responsibilities in the event of an aircraft accident involving Navy personnel. If these responsibilities are met fully, a flight surgeon can make a real contribution to the understanding of the causes of aircraft accidents, to continued improvements in protective clothing and equipment, and to an ever-improving safety record in naval aviation.

In summary, the postmortem examination of an accident victim can provide important information on the causes of an accident, information not obtainable through any other source. However, for the autopsy examination to be most effective, there are three issues which must be faced.

Aircraft Accident Autopsies

1. As stated previously, there are many instrumentalities of government to be dealt with in handling a fatality, particularly when the accident does not occur on federal property. It is particularly important for a naval activity's premishap plan to include arrangements for ensuring the immediate retrieval of remains. These arrangements can be expedited by establishing liaison with local authorities and physicians prior to any accident. Provision should also be made for consultations with the legal officer representing the naval district or the supporting naval air station.

2. The flight surgeon should participate to the fullest extent possible in the aviation autopsy examination. The pathologist may be an outstanding examiner with a wealth of experience in performing routine postmortem examinations, but is rare indeed when his experience includes expertise in handling remains from aircraft accidents. The flight surgeon makes an important contribution, therefore, by defining the questions that should be asked in the examination. The pathologist relies on the flight surgeon and his understanding of aviation operations, current aircraft, protective equipment, and specific aircraft systems to ensure that the right questions are addressed. An aviation physiologist working with the team can often further characterize the relationship of injuries.

3. The requirement for a flight surgeon to participate in the deliberations of an Aircraft Mishap Board is contained in the OPNAV Instruction of the 3750.6 series. Chapter 23, *Aircraft Accident Investigations*, elaborates on the various duties of the flight surgeon as a member of this board. A few words are in order here, however, concerning the disposition of issues which may arise during the autopsy examination.

There is a requirement that the Aircraft Mishap Board and the flight surgeon, working together, address any problem that arises in the medical investigation which is of significant import. The Aircraft Accident Report and the Flight Surgeons Report must be complementary. This does not mean that they must say the same thing. It is interpreted to mean that the same issues must be treated, and evidence must be presented that the two sides have communicated on medical issues of significance and that each has developed its position addressing that problem. If for some reason the flight surgeon feels that medical issues are not being given adequate attention in deliberations of the full Aircraft Mishap Board, he can note this in the Flight Surgeon's Report, or he can communicate directly with the Naval Safety Center. He does bear the responsibility for seeing that medical findings that may have relevance in determining accident causation or in improving issues of aviation safety are given full weight in the conclusions of the Aircraft Mishap Board.

Table 25-2

Deceleration Injuries Based on Anatomic Location

Location	Injury	G-Force
Neck	Paraspinal Hemorrhage	25-35
Lungs	Contusions	25-25
Aorta	Medial Tears	50
	Intimal Tears	50-80
	Transections	80+
Vertebra	Disc Transection	50-80
	Body Fractures	100-200
	Compression Fractures	15-30
Pelvis	Disarticulation	200-300
Body	Fragmentation	350

The above figures are estimates based on calculated forces in actual aircraft mishaps in which these injuries were observed and not attributed to direct impacts.

Reconstruction of the mishap scenario by injury patterns requires the separation of observed injuries into discrete categories. Major categories in aircraft mishaps include deceleration, direct impact, flailing, intrusion, thermal and environmental.

References and Bibliography

- Aerospace pathology for the flight surgeon*. Washington DC: Armed Forces institute of Pathology, 1987.
- American Academy of Orthopedic Surgeons symposium on the spine*, Cleveland, November 1967. St. Louis: C.V. Mosby, p. 29.
- Anderson. W.A.D. *Pathology* (6th ed.). St. Louis: C.V. Mosby, 1971.
- Blackwood, W., et al. (Eds.). *Greenfield's neuropathology* (2nd ed.). Baltimore: Williams and Wilkins, 1963.

Aircraft Accident Autopsies

- Clark, D.H. Dental identification problems in the Abu Dhabi air accident. *American Journal of Forensic Medicine and Pathology*, 1986, 7 (4), 317-321.
- Colangelo, E. J. The cervicocranium and the aviator's protective helmet. *U.S. Navy Medicine*, 1974 64, 32-34.
- Coltart, W.D. Aviator's astragalus. *Journal of Bone and Joint Surgery*, 1952, 32B; 545.
- Davis, J.H. Bodies found in water: An investigate approach. *American Journal of Forensic Medicine and Pathology*, 1986. 7 (4), 291-297.
- DeHart, R.L. *Fundamentals of aerospace medicine*. Philadelphia: Lea & Febrieger, 1985.
- DePalma, A.F. *The management of fractures and dislocations, an Atlas*. Philadelphia: W.B. Saunders, 1981.
- Department of the Navy, Office of the Chief of Naval Operations. Navy aircraft accident, incident, and ground accident reporting procedures (OPNAVINST 3750.6 series).
- Gilliland, M.G.F., McDonough, E.T., Fossum, R.M., Dowling, G.P., Besant-Matthews, P.E., & Petty, C.S. Disaster planning for air crashes: A retrospective analysis of Delta Airlines Flight 191. *American Journal of Forensic Medicine and Pathology*, 1986, 7 (4), 308-316.
- Gould, S.E. *Pathology of the heart and blood vessels* (3rd ed.). Springfield, IL: Charles C. Thomas, 1968.
- Hill, I.R. The immediate problems of aircraft fires. *American Journal of Forensic Medicine and Pathology*, 1986, 7 (4), 271-277.
- Hill, I.R. Toxicological findings in fatal aircraft accidents in the United Kingdom. *American Journal of Forensic Medicine and Pathology*, 1986, 7 (4), 322-326.
- Kreffft, S. Who was in the controls when the fatal accident occurred? *Aerospace Medicine*, 1970, 41, 785.
- Kulund, D.N. *The injured athlete*. Philadelphia: J.B. Lippincott, 1982.
- Mason, J.K. *Aviation accident pathology*. London: Butterworth, 1962.
- Mason, J.K., & Reals, W.J. *Aerospace pathology*. Chicago: College of American Pathologists' Foundation, 1973.
- Randel, H.W. *Aerospace medicine* (2nd ed.). Baltimore: Williams and Wilkins, 1971.
- Reals, W.J. (Ed.). *Medical investigation of aviation accidents*. Chicago: College of American Pathologists, 1968.
- Robbins, S.L., Cotran, R.S. & Kumar, V. *Pathologic basis of disease* (3rd ed.). Philadelphia: W.B. Saunders, 1984.
- Schneider, R.C., Livingston, K.E., Cave, A.J.E., & Hamilton, G. Hangman's fracture of the cervical spine. *Journal of Neurosurgery*, 1965, 22 (2).
- Schwender, L.A., & Tronocoso, J.C. Evaluation of sudden death in epilepsy. *American Journal of Forensic Medicine and Pathology*, 1986, 7 (4) 283-287.
- Shephard, R.J. *Physiology and biochemistry of exercise*. New York: Praeger Pub., 1982.

U.S. Naval Flight Surgeon's Manual

Spencer, J.D. Medical examiner/coroner jurisdiction in cases involving Federal interests. *Journal of Forensic Sciences*, 1982, 27 (2), 408-411.

Spitz, W.U., & Fisher, R.S. *Medicolegal investigation of death*. Springfield, IL: Charles C. Thomas, 1973.

Tedeschi, C.G., Eckert, W.G., & Tedeschi, L.G. *Forensic medicine*. Philadelphia: W.B. Saunders, 1977.

Vesterby, A., Gregersen, M., & Baandrup, U. The myocardium in epileptics. *American Journal of Forensic Medicine and Pathology*. 1986, 7 (4), 288-290.

Wood-Jones, F. The ideal lesion produced by judicial hanging. *Lancet* 1913, 1, 53.

APPENDIX A

HISTORICAL CHRONOLOGY OF AEROSPACE MEDICINE IN THE U.S. NAVY

- 8 Oct 1912 The first physical requirements for prospective naval aviators defined in Bureau of Medicine and Surgery Circular Letter 125221.
- 8 Nov 1921 Five Navy medical officers report to the Army's School for Flight Surgeons at Mitchell Field, Long Island, New York.
- 29 Apr 1922 Navy's first five flight surgeons designated. Graduates are: Lieutenants Victor S. Armstrong, Louis Iverson, Julius F. Neuberger, Page O. Northington, and Carl J. Robertson.
- 1922 Lieutenant Bertram Groesbeck becomes the first naval medical officer to complete flight training and be designated a naval aviator. Upon completion of flight training, Groesbeck reports to the Army School for Flight Surgeons, graduating on 27 April 1923.
- 1923 Lieutenant Victor S. Armstrong, MC, USN, becomes the first Chief of the Aviation Medicine Division, Bureau of Medicine and Surgery.
- 14 Nov 1924 Chiefs of the Bureau of Aeronautics and the Bureau of Medicine and Surgery agree upon the qualifications for designation as a naval flight surgeon. These included a three-month course at the U.S. Army School of Aviation Medicine and three months of satisfactory service with a naval aviation unit prior to designation. The requirement that a medical officer so qualified also make flights in aircraft was limited to emergencies and to the desire of the officer.
- 18 Jan 1927 First course of instruction for flight surgeons to be given in the U.S. Navy is initiated. The three-month course was conducted at the Naval Medical School, Washington, D.C., located in the Naval Observatory.
- 28 July 1932 Research into the physiological effects of high acceleration and deceleration, as encountered in dive-bombing and other violent maneuvers, is initiated by the

U.S. Naval Flight Surgeon's Manual

Bureau of Medicine and Surgery. This pioneer research pointed to the need for anti-G or antiblackout equipment and was conducted at the Harvard University School of Public Health by Lieutenant Commander John R. Poppen, MC, USN.

- 24 Oct 1933 Development of the first antiblackout program is initiated by the Naval Aircraft Factory to develop and manufacture a special abdominal belt in accordance with specifications prepared by Lieutenant Commander John R. Poppen, MC, USN. This belt was to be used by pilots, in dive-bombing and other violent maneuvers, in order to protect against blackout.
- Jan 1935 Lieutenant Commander John R. Poppen, MC, USN, is the first flight surgeon to be assigned to the Naval Aircraft Factory to conduct work on the physiologic aspects of the research and development projects being carried on at the factory.
- 24 Aug 1939 A medical officer is detailed to the Bureau of Aeronautics for the purpose of establishing an aviation medical research unit.
- 20 Nov 1939 The first instruction in aviation medicine at the Naval Air Station, Pensacola, Florida, begins with the reporting of nine reserve medical officers to the Medical Department. Thus began the Navy School of Aviation Medicine. The first class was graduated on 20 January 1940 as Aviation Medical Examiners after a 60-day course of instruction.
- 15 May 1940 The first medical air-evacuation flight is conducted from a U.S. Navy Ship when an XSOC-1 aircraft, piloted by Lieutenant G.L. Heap, transferred an injured seaman from the destroyer USS *Noa*, at anchor in the Delaware River, to the Naval Hospital, Philadelphia, Pennsylvania.
- July 1940 The '1,000 Aviator' study is initiated by the Harvard Research Group, sponsored by the Civil Aeronautics Authority, the National Research Council, and the U.S. Navy. This group conducted a complete physiological and psychological study on a total of 1056 students and instructors at Pensacola. The studies included electrocardiograms, electroencephalograms, somatotyping and cardiac workups. Follow-up study on this original group of students and instructors has continued at intervals through the years.
- 30 Nov 1940 First naval flight surgeons graduate from the School of Aviation Medicine.

Historical Chronology of Aerospace Medicine in the U.S. Navy

- 1941 Captain John R. Poppen, MC, USN, becomes the first military flight surgeon to hold the position of President of the Aeromedical Association.
- 24 Feb 1941 A new building is dedicated to house the expanding Naval School of Aviation Medicine at Pensacola. Prior to this time, the school occupied quarters in the air station dispensary.
- June 1941 First altitude training unit is established at Naval Air Station Pensacola, to indoctrinate all aviation personnel in the use of oxygen and oxygen equipment, and in the physiological and psychological effects of hypoxia. Other units were rapidly established at major air training bases. The designation of these units was later changed to Aviation Physiology Training Units.
- 18 May 1942 Chief of Naval Personnel authorizes breast device to be worn by officers of the Medical Corps who qualified as naval flight surgeons.
- 27 June 1942 Work initiated by the Controlled Elements Group, Aeronautical Materials Section of the Naval Aircraft Factory, on the development of high altitude pressure suits.
- 19 July 1942 First pair of flight surgeon wings presented to Captain Frederick Ceres, MC, USN. The wings, fashioned by the NAS Dental Department, are presented by Captain A.C. Read, Commandant, Naval Air Station, Pensacola.
- 10 Oct 1942 Secretary of the Navy authorizes naval flight surgeons to be included as “flying officers” entitling them to draw flight pay while detailed to duty involving flying. Prior to this time, flight surgeons drew flight pay at the discretion of their commanding officer.
- 5 Nov 1942 Commander Eric E. Liljencrantz, MC, USNR, is the first navy flight surgeon to be killed in an aircraft accident. Commander Liljencrantz was killed in the crash of a dive-bomber while acting as observer in an aeromedical research project.
- 17 Jan 1943 Tests conducted at NAS San Diego by pilots flying F4U-1s report that the anti-blackout suits developed at the Naval Aircraft Factory increased their tolerance to the accelerations encountered in gunnery runs and other maneuvers by three to four Gs.

U.S. Naval Flight Surgeon's Manual

- 30 Nov 1943 The Aeromedical Department, under a naval flight surgeon, established as a separate group within the Naval Air Experimental Station, Philadelphia, Pennsylvania with increased responsibilities in the area of physiological factors involved in aeronautical equipment and aircraft design.
- March 1944 First night vision training unit established at Naval Auxiliary Air Field, Charleston, South Carolina, to determine the advisability of using a Canadian-developed night vision trainer in the Navy's program. The need for adequate night vision training of aviation personnel was becoming of greater concern due to the increasing use of night fighter aircraft. The first demonstrations to the U.S. Navy medical and aviation personnel were made by Wing Commander K.A. Evelyn, RCAF, at Charlestown, Rhode Island, in the spring of 1944.
- 1 Sept 1944 Mary F. Keener, first designated Aviation Physiologist, comes on active duty.
- 12 Dec 1944 Three evacuation squadrons commissioned in the Pacific from air-sea rescue squadron elements to provide evacuation services.
- 17 Mar 1945 Responsibility for evacuation of wounded personnel assigned to the Naval Air Transport Service.
- 3 Apr 1945 Commodore John C. Adams, MC, USN, becomes first practicing flight surgeon promoted to flag rank. This occurred following a distinguished career in aviation medicine, more than ten years of which was in the position of Chief of the Division of Aviation Medicine, Bureau of Medicine and Surgery.
- January 1946 Training of Aviation Medicine Technicians and Low Pressure Chamber Technicians begins at the Naval School of Aviation Medicine. Previous instruction had been done at local dispensaries.
- August 1946 The Aeromedical Department, Naval Air Experimental Station, Philadelphia, redesignated at the Aeronautical Medical Equipment Laboratory, with a flight surgeon as superintendent in charge.
- 14 Aug 1946 Aeronautical Medical Equipment Laboratory, Philadelphia, begins human and equipment investigation relating to the development of an ejection seat to be used for emergency escape from aircraft, utilizing a 150-foot ejection seat test tower obtained from Great Britain.

Historical Chronology of Aerospace Medicine in the U.S. Navy

- 15 Oct 1946 The School of Aviation Medicine in Pensacola, previously a part of the station Medical Department, officially designated by the Secretary of the Navy as the U.S. Naval School of Aviation Medicine and Research, with its own officer in charge. This officer was Captain Louis Iverson, MC, USN.
- May 1949 First ejection seat training is given to naval pilots utilizing the Martin-Baker ejection seat test tower at the Aeronautical Crew Equipment Laboratory, Philadelphia.
- 24 May 1949 Aviation Medical Acceleration Laboratory, Naval Air Development Center, Johnsville, Pennsylvania, established by Chief of Naval Operations with its mission to perform research and development in the field of aviation medicine pertaining to the human centrifuge. Captain J.R. Poppen, MC, USN, was the first laboratory director.
- 9 Aug 1949 First successful use in the United States of a pilot ejection seat for emergency escape is made from an F2H-1 Banshee exceeding 500 knots in the vicinity of Walterboro, South Carolina.
- 1950 Helicopters used for the first time in the air evacuation of wounded patients in Korea.
- January 1951 First class of Aviation Physiologists come onboard School of Aviation Medicine.
- March 1951 First ejection seat trainer delivered to the Naval Air Station, North Island, San Diego, California. This training device, which simulates the ejection seat in the Grumman F9F fighter, was designed to provide a realistic means of training pilots in the correct procedures and characteristics of seat ejection and to promote confidence in the use of this method of escape.
- 9 July 1951 School of Aviation Medicine, Pensacola commissions a separate command with a medical officer as commanding officer. Captain Leon D. Carson, MC, USN, first commanding officer.
- 1 Aug 1951 The HG-1 (high acceleration) catapult transferred from Naval Aircraft Factory, Philadelphia, to the Aeronautical Medical Equipment Laboratory, Naval Experimental Station, Philadelphia. This gave the laboratory a valuable

U.S. Naval Flight Surgeon's Manual

research tool for use in the study of restraint methods and equipment to protect occupants from injury in aircraft crashes.

- 17 June 1952 Aviation Medicine Acceleration Laboratory at Naval Air Development Center, Johnsville, commissioned, and its human centrifuge with a 50-foot arm and capable of producing accelerations up to 40 Gs put into operation as a research tool for investigating the reaction of flyers to the accelerations encountered in flight at various temperatures and altitudes.
- 1 Apr 1955 Incentive pay authorized for low-pressure chamber inside instructors and observers and human test subjects participating in research projects.
- 30 June 1955 The first operational full-pressure suits, a Navy development, placed in service to protect aviators at high altitudes in the event of loss of cabin pressurization. The suit was designed to protect men while in a space environment.
- 8 July 1956 School of Aviation Medicine, Pensacola, approved a two year formal residency program in aviation medicine by the American Board of Preventive Medicine.
- 19 Dec 1956 Chief of Naval Air Training establishes the Special Board of Flight Surgeons. This permanent board of medical officers appointed at the Naval School of Aviation Medicine, Pensacola, 'To provide prompt and highly competent professional review of the physical qualifications of aviation trainees and to expedite processing of those not qualified to continue training.' Senior member of the board is the commanding officer of the School of Aviation Medicine.
- 1 Feb 1957 Lieutenant Commander Frank H. Austin, Jr., MC, USN, completes test pilot training at Naval Air Test Center, Patuxent River, Maryland. He was the first Navy flight surgeon to qualify as a test pilot.
- 30 Apr 1957 Naval Aviation Medical Center at Pensacola commissioned, combining under a single command the clinical, training, and research functions of the Naval School of Aviation Medicine and the Naval Hospital, Pensacola. First commanding officer is Captain Lester McDonald, MC, USN.
- June 1957 Johnsville human centrifuge hooked into the analog computer "Typhoon" so that dynamic control simulation is possible and subjects in the centrifuge gondola can actually "fly" the device, simulating the flight characteristics of any selected type of aircraft.

Historical Chronology of Aerospace Medicine in the U.S. Navy

- 28 June 1957 A successful ground-lever ejection demonstrated at Naval Air Station, Patuxent River, Maryland. Aviation Medicine Branch of Service Test participated in this demonstration.
- 15 Nov 1957 Incentive pay authorized for, human test subjects in thermal stress experiments.
- March 1958 Bioastronautics Test Facility put into operation at Air Crew Equipment Laboratory, Philadelphia. This facility permits the confinement and isolation of up to six human subjects under simulated space capsule conditions for indefinite periods of time at any simulated altitude from sea level to 100,000 feet.
- June 1958 Human Disorientation Device installed at the Naval School of Aviation Medicine, Pensacola. This device offers a means of studying the causes of vertigo and disorientation in aviators and provides a means for evaluating possible protective procedures.
- 8 Aug 1958 Lieutenant R.H. Tabor, MC, USN, completes a 72-hour simulated flight in the pressure chamber at the Aviation Physiology Training Unit, NAS Norfolk while wearing a Goodrich light-weight full pressure suit. During this time he was subjected to altitude conditions as high as 98,000 feet.
- 13 Dec 1958 The Navy-trained squirrel monkey "Gordo" (Old Reliable) makes a suborbital flight into space. He successfully withstood the flight and reentry, as evidenced by the telemetered data, but was lost when the nose cone in which he was riding sank due to failure of the flotation gear. Scientists at the School of Aviation Medicine were responsible for the design and fabrication of the biocapsule in which "Gordo" rode and for its instrumentation.
- 28 May 1959 Miss Baker (Tender Loving Care), a squirrel monkey trained at the School of Aviation Medicine, becomes the first primate to survive a suborbital space flight. Upon her return to earth, she was set up in an "apartment" at the school where she remained until 1971. In 1971 she was transferred to the Army's space museum in Huntsville, Alabama.
- June 1959 The seven Mercury astronauts participate in centrifuge simulations of Atlas rocket launches, reentries, and abort conditions ranging up to plus 18 G (transverse), at the Aviation Medical Acceleration Laboratory, Johnsville. These simulations were conducted on the large human centrifuge located at that facility.

U.S. Naval Flight Surgeon's Manual

- 4 May 1961 The Navy's high altitude balloon flight, Strato-Lab No. 5, ascends from the deck of the carrier *USS Antietam* to an altitude of 113,000 feet with a flight duration of 8.9 hours. The flight carried Commander Malcolm D. Ross as a pilot and Lieutenant Commander Victor A. Prather, a naval flight surgeon, as medical investigator. The occupants rode in an open framework gondola and were protected from the effects of reduced barometric pressure by their Navy-developed full pressure suits. This successful experimental flight was marred by the drowning of Lieutenant Commander Prather during the recovery phase of the flight.
- 22 July 1964 The Coriolis Acceleration Platform (CAP) and vestibular unit dedicated at the School of Aviation Medicine, Pensacola.
- 14 May 1965 Dedication of new buildings (Buildings 1953 and 1954) for the School of Aviation Medicine, Pensacola.
- 28 June 1965 Lieutenant Commander Joseph P. Kerwin, MC, USN, naval flight surgeon and naval aviator, selected as one of the first physician-astronauts in the U.S. space program.
- 2 Aug 1965 The first flash blindness indoctrination trainer device, 18F22, installed at Marine Corps Air Station, Beaufort, South Carolina. This device exposes the subject to a simulated nuclear blast light flash and demonstrates the resulting temporary blindness that occurs without protection. It also demonstrates the protection offered by flash blindness protective devices.
- Sept 1965 Lieutenant Paul A. Furr, MSC, USN, is the first Aviation Physiologist to qualify as a test parachutist and to be designated as a naval parachutist. Furr is qualified to wear the Navy and Marine Corps Parachutist insignia.
- 2 Sept 1965 The Naval School of Aviation Medicine is redesignated the Naval Aerospace Medical Institute, (NAMI).
- 24 Sept 1965 Captain Mary F. Keener, MSC, USN, an Aviation Physiologist, is the first woman officer on active duty to be promoted to the rank of captain in the Medical Service Corps, U.S. Navy.
- 10 Jan 1966 The Secretary of the Navy approves the designation of Aviation Experimental

Historical Chronology of Aerospace Medicine in the U.S. Navy

Psychologists and Aviation Physiologists as flying officers and orders them to duty involving flying.

- 7 Apr 1966 Ensign Gale Anne Gordon, MSC, USNR, completes the course of training in aviation experimental psychology at the Naval Aerospace Medical Institute. On 28 March 1966, Ensign Gordon became the first woman to solo in a naval aircraft.
- 11 Apr 1966 Captain Mary F. Keener, MSC, USN, is elected vice president of the Aerospace Medical Association during its 38th annual convention, becoming the first Navy woman ever to hold that office.
- 12 Apr 1966 The Assistant Secretary of the Navy officially authorizes wearing of wings by the Navy's Aviation Physiologists and Aviation Experimental Psychologists.
- 1 July 1967 The Aerospace Crew Equipment Laboratory (formerly the Aeronautical Crew Equipment Laboratory) officially transferred from the command of the Naval Air Engineering Center, Philadelphia, to the command of the Naval Air Development Center, Johnsville, Pennsylvania, and redesignated the Aerospace Crew Equipment Department.
- 7 July 1967 The first change in the visual acuity standards for carrier pilots since before World War II is made when Service Group One naval aviators are allowed to fly with a visual acuity of 20/50 corrected to 20/20 provided glasses are worn while in actual control of aircraft.
- 25 July 1967 The Naval Aerospace Medical Institute begins conducting a complete radiological examination of the vertebral column of all personnel in the flight training program, as part of the program to reduce possible causes of back injuries due to an emergency ejection escape from naval aircraft.
- 19 Jan 1970 The Naval Aerospace Medical Research Laboratory is designated a component command of the Naval Aerospace Medical Institute. First officer in charge is Captain Newton W. Allebach, MC, USN.
- 22 June 1973 Commander Joseph P. Kerwin, MC, USN(FS) completed 28 days in space as part of the all Navy crew onboard Skylab.

U.S. Naval Flight Surgeon's Manual

- 1 July 1974 The Naval Aerospace Medical Institute becomes a command under the newly formed Naval Health Sciences Education and Training Command. The Naval Aerospace Medical Research Laboratory, (NAMRL) a component command of the Naval Aerospace Medical Institute, becomes a separate command under BUMED's Research and Development Command. First commanding officer of NAMRL is Captain Newton Allebach, MC, USN.
- 5 May 1975 The first class of Aviation Medical Officers (AMOs) reports to the Naval Aerospace Medical Institute for four weeks of training. AMOs are assigned as flight surgeon expanders to aviation activities.
- Summer 1976 The Repatriated Prisoner of War (RPW) study, being conducted on former Navy and Marine Corps prisoners of the Vietnam Conflict, becomes the responsibility of the Naval Aerospace Medical Research Laboratory. Since January 1974, the responsibility for the study had been a function of the Naval Aerospace Medical Institute.
- December 1977 First session of US Navy Flight Surgeon's Manual completed.
- July 1980 The Repatriated Prisoner of War study was transferred from NAMRL to NAMI.
- 1 April 1980 The Naval Aerospace Medical Institute became an Echelon Three command reporting directly to Bureau of Medicine and Surgery.
- 12 April 1984 The Multi-Station Spacial Disorientation Demonstrator was accepted by NAMI from American Airlines. Located in Building 3801, this unique training device is used to demonstrate a variety of visual and perceptive illusions to all aircrew candidates.
- 22 May 1984 Commander M.L. (Sonny) Carter, MC, USN, was selected as a NASA Mission Specialist for future Space Shuttle flights.
- Summer 1985 Aerospace Medicine Residency program at NAMI was increased to five residents per year to provide for operational needs.
- 29 June 1989 Lieutenant Commander Michael H. Mittelman, MSC, USN was designated the first Aerospace Optometrist.

Historical Chronology of Aerospace Medicine in the U.S. Navy

Bibliography

- Adams, J.C. Personal interview, 1976.
- Adams, J.C. Developments in aviation medicine. In *The History of the Medical Department of the United States Navy in World War II* (NAVMED P-5031, Vol. 1). Washington, DC: U.S. Government Printing Office, 1953.
- Barr, N.L. Night vision training. In *The History of the Medical Department of the United States Navy in World War II* (NAVMED P-5031, Vol. 1). Washington, DC: U.S. Government Printing Office, 1953.
- Benford. R.J. *Doctors in the sky*. Springfield, IL: Charles C. Thomas, 1955.
- Courtney, M.D. Bureau of Medicine and Surgery internal memorandum, 1 September 1967.
- Hodge, W. A history of aerospace medicine in the U.S. Navy. In *U.S. Naval Flight Surgeon's Manual*. Washington, DC: U.S. Government Printing office, 1968.
- Kellum, W.C. Personal interview and uncirculated letter, 1976.
- Naval School of Medicine. *CONTACT* (newsletter). Pensacola, FL., Vols. 1-17, 1941-59.
- West, V.R., Every, M.G., & Parker, J.F., Jr. History of the naval aerospace physiology program. In *U.S. Naval Aerospace Physiologist's Manual* (NAVAIR 0040T-99). Philadelphia, PA: Naval Air Engineering Center, September 1972.
- Williams, N.E. High altitude training. In *The History of the Medical Department of the United States Navy in World War II* (NAVMED P-5031, Vol. 1). Washington, DC: U.S. Government Printing Office, 1953.
- Yanquell, C.C. Personal uncirculated letter, 1976.

U.S. Naval Flight Surgeon's Manual

**NAVY FLIGHT SURGEONS ACHIEVING
POSITIONS OF LEADERSHIP AND COMMAND**

**Head of Aerospace Medicine
Bureau of Medicine and Surgery**

LT Victor S. Armstrong, MC, USN Chief, Section on Aviation Medicine	Apr 1923 - Jan 1925
LT R.P. Henderson, MC, USN Chief, Section on Aviation Medicine	Jan 1925 - Sept 1926
CDR Robert G. Davis, MC, USN Chief, Section on Aviation Medicine	Sept 1926 - May 1929
LCDR John R. Poppen, MC, USN Chief, Section on Aviation Medicine	June 1929 - Oct 1929
LCDR Joel J. White, MC, USN Chief, Section on Aviation Medicine	Oct 1929 - May 1933
Captain Louis E. Mueller, MC, USN Chief, Section on Aviation Medicine	May 1933 - Apr 1937
Rear Admiral John C. Adams, MC, USN Chief, Section on Aviation Medicine	Apr 1937 - Dec 1946
In 1944 title changed to Assistant Chief for Aerospace Medicine	
Rear Admiral B. Groesbeck, Jr., MC, USN Assistant Chief for Aerospace Medicine	Jan 1947 - Apr 1952
Rear Admiral W. Dana, MC, USN Assistant Chief for Aerospace Medicine	Apr 1952 - Aug 1957
Captain Oran W. Chenault, MC, USN Assistant Chief for Aerospace Medicine	Aug 1957 - July 1959

Historical Chronology of Aerospace Medicine in the U.S. Navy

Captain M.H. Goodwin, MC, USN Assistant Chief for Aerospace Medicine	Oct 1959 - Feb 1963
Captain H.C. Hunley, MC, USN Assistant Chief for Aerospace Medicine	Feb 1963 - May 1964
Captain W.M. Snowden, MC, USN Assistant Chief for Aerospace Medicine	May 1964 - July 1968
Captain Leonard P. Jahnke, MC, USN Assistant Chief for Aerospace Medicine	Aug 1968 - June 1971
Captain Edward A. Jones, MC, USN Assistant Chief for Aerospace Medicine	Aug 1971 - Dec 1973
Captain Frank H. Austin, Jr., MC, USN Assistant Chief for Aerospace Medicine	Jan 1974 - Sept 1976

In July 1974 title changed to Director, Aerospace Medicine Division

Captain M.G. Webb, Jr., MC, USN	1976 - 1979
Captain D.B. Lestage	1979 - 1981
Captain F.R. Deane	1981 - 1983
Captain R.D. Symonds	1983 - 1985
Captain J.C. Emery	1985 - 1987
Captain R.K. Ohslund	1987 - 1988
Captain W.M. Houk	1988 - 1989

Officer in Charge

Naval School of Aviation Medicine and Research

Captain Fredrick Ceres, MC, USN*	Nov 1938 - June 1942
Captain Bertram Groesbeck, MC, USN*	June 1942 - Nov 1944
Captain Louis Iverson, MC, USN*	Nov 1944 - Jan 1947
Captain Bruce V. Leamer, MC, USN**	Jan 1947 - July 1947

U.S. Naval Flight Surgeon's Manual

Captain Wilbur E. Kellum, MC, USN	July 1947 - Feb 1950
Captain Leon D. Carson, MC, USN	Feb 1950 - July 1951

*ADDU from NAS Pensacola where assigned as Senior Medical Officer.

**First person to receive orders for duty as Officer in Charge.

Commanding Officer

Naval School of Aviation Medicine and Research

Captain Leon D. Carson, MC, USN	July 1951 - June 1952
Captain James L. Holland, MC, USN	June 1952 - July 1954
Captain Julius C. Early, Jr., MC, USN	July 1954 - July 1957
Captain Langdon C. Newman, MC, USN	July 1957 - Aug 1960
Rear Admiral Langdon C. Newman, MC, USN	Aug 1960 - Oct 1960
Captain Clifford P. Phoebus, MC, USN	Oct 1960 - Aug 1964
Captain Henry C. Hunely, Jr., MC, USN	Aug 1964 - Sept 1965

Commanding Officer

Naval Aerospace Medical Institute

Captain Henry C. Hunely, Jr., MC, USN	Sept 1965 - May 1967
Captain Joseph W. Weaver, MC, USN	May 1967 - July 1969
Captain Marvin D. Courtney, MC, USN	July 1969 - July 1972
Captain Robert C. McDonough, MC, USN	July 1972 - June 1974
Captain Henry S. Trostle, MC, USN	July 1974 - Sept 1979
Captain R. Paul Caudill, MC, USN	Sept 1978 - July 1982
Captain Patrick F. O'Connel, MC, USN	July 1982 - Sept 1982
Captain Frank E. Dully, MC, USN	Sept 1982 - Aug 1985
Captain Richard A. Millington, MC, USN	Aug 1985 - June 1988
Captain Ronald K. Ohslund, MC, USN	June 1988 - June 1990
Captain Charles H. Bercier, Jr., MC, USN	June 1990 - Present

Historical Chronology of Aerospace Medicine in the U.S. Navy

Commanding Officer

Naval Aerospace Medical Research Laboratory

Captain Newton W. Allenback, MC, USN	Jul 1974 - Aug 1975
Captain Robert E. Mitchell, MC, USN	Aug 1975 - May 1980
Captain William M. Houk, MC, USN	May 1980 - Jun 1985
Captain James O. Houghton, MC, USN	Jun 1985 - Jun 1988
Captain James A. Brady, MSC, USN	Jun 1988 - Present.

Navy Presidents of Aerospace Medical Association

Captain John R. Poppen, MC, USN	1941- 1942
Rear Admiral John C. Adams, MC, USN	1946 - 1947
Captain Wilbur E. Kellum, MC, USN	1949 - 1950
Rear Admiral B. Groesbeck, Jr., MC, USN	1953 - 1954
Captain Ashton Graybiel, MC, USN	1957 - 1958
Rear Admiral James J. Holland, MC, USN	1961 - 1962
Captain Frank B. Voris, MC, USN	1966 - 1967
Captain Ralph L. Christy, MC, USN	1970 - 1971
Captain Frank H. Austin, Jr., MC, USN	1976 - 1977
Captain Ronald K. Ohslund, MC, USN	1984 - 1985
Rear Admiral Daniel B. Lestage, MC, USN	1988 - 1989

